

CLARK

GTS

20/25/30/33



MAX LOAD CAPACITY
4000 / 5000 / 6000 / 6600 LBS.
(2000 / 2500 / 3000 / 3300 KG)

CLARK

GTS

With 8 configurations, the GTS is perfectly suited for both indoor and outdoor applications and can tackle even the toughest jobs with ease.

SAFETY

The GTS was designed with safety in mind, with several built-in safety features that protect the operator and pedestrians. Safety has been a cornerstone of CLARK design for over 100 years, and the GTS is no exception. Key safety features include:

- Operator Presence System
- Ratchet Style Parking Brake disengages transmission, preventing driving through brake
- High-Visibility Orange Seat Belt
- Nested I-Beam Upright for increased visibility
- Dash with warning lights for fuel, engine alerts, and more

LOW OVERALL COST OF OWNERSHIP

The GTS is a rugged and durable solution for customers in need of a reliable truck with a low cost of ownership. There are several key design elements that make the GTS one of the most cost-effective units available to customers, including:

- Static Oil Cooled Wet Disc Brakes that extend brake life without adjustments
- Automotive type fuse box for ease of maintenance internally
- Dash display with fault codes to assist in troubleshooting without costly repairs

OPTIMIZED FOR THE OPERATOR

The CLARK GTS is the operator's choice for comfort, reliability, and ease of serviceability. Some of the great operator-focused features include:

- Low Step Height
- Full suspension seat for maximum operator comfort
- 8 configurations available for maximum flexibility
- Digital Dash Display with warning lights and truck status



GTS

OPERATOR COMPARTMENT

ERGONOMICS



- 17.5" step height
- Tilt Steering Column for Ease of Entry & Exit
- Full Suspension Seat
- 12.5" Steer wheel with spinner knob standard
- Comfortable rubber floor mat for reduced noise and vibration
- Hydrostatic power steering allows for less steering effort overall
- Welded grab bars for ease entry/exit

BRAKES



- Static oil-cooled wet disc brakes
- Require less pedal effort than traditional drum brakes
- Wet-disc brakes minimize wear and tear, decreasing the need for maintenance
- Secure Parking Brake prevents drive through



ANSI/ITSDF and Insurance Classification

Standard truck meets all applicable mandatory requirements of Part III-ANSI/ITSDF B56.1 Safety Standard for Powered Industrial Trucks and Underwriters Laboratories requirements as to fire hazard only for D and LP classifications. For further information contact a CLARK representative. Users should be aware of, and adhere to, applicable codes and regulations regarding operator training, use, operation and maintenance of powered industrial trucks, including: ANSI/ITSDF B56.1; NFPA 505, fire safety standard for powered industrial trucks - type designations, areas of use, maintenance and operation; and Occupational Safety and Health Administration (OSHA) regulations that may apply.

Contact your authorized CLARK forklift truck dealer for further information including operator training programs and auxiliary visual and audible warning systems, fire extinguishers, etc., as available for specific user applications and requirements. Specifications, equipment, technical data, photos and illustrations are based on information at time of printing and are subject to change without notice.

Some products may be shown with optional equipment.

GTS

DURABILITY

RUGGED UPRIGHT + CARRIAGE

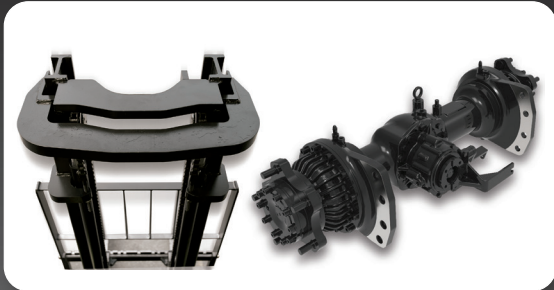

- Nested I-Beam Design provides greater visibility through positive rail interlock and a narrow “column” in field of vision
- Six carriage rollers and two side-thrust rollers minimize deflection and side play, maximizing component life
- Hydraulic cushioning valves provide silent staging of the rails to reduce shock during lowering and lifting
- Overhead guard safety bar designed for maximum operator visibility

HIGH PERFORMANCE ENGINES



- HMC Theta 2.4 L LPG Engine available in Tier 0 and Tier 4
- 4-cylinder Dual Overhead Cam Design
- Timing Chain—Increased Durability and Reduced Maintenance Cost
- Aluminum Block with Iron Liners and Aluminum Head
- Improved Fuel Economy and Longer Engine Life



& Don't Forget...Safety Starts With You!

Before operating a lift truck, an operator must:

- Be trained and authorized
- Read and understand operator's manual
- Not operate a faulty lift truck
- Not repair a lift truck unless trained and authorized
- Have the overhead guard and load backrest extension in place
- Perform daily inspections

During operation, a lift truck operator must:

- Wear a seat belt
- Keep entire body inside truck cab
- Never carry passengers or lift people
- Keep truck away from people and obstructions
- Travel with lift mechanism as low as possible and tilted back
- Allow safe stopping distance and come to a complete stop before leaving operator compartment

To park a lift truck, an operator must:

- Completely lower forks or attachments
- Shift into neutral
- Turn key off
- Set parking brake

GTS

GENERAL DATA & STANDARD DIMENSIONS: GTS 20/25/30/35

Specifications	1.1	Manufacturer		CLARK	CLARK	CLARK	CLARK
	1.2	Manufacturer's Designation		GTS20L	GTS25L	GTS30L	GTS33L
	1.3	Drive unit Diesel, L.P. Gas		LPG	LPG	LPG	LPG
	1.4	Operator type stand on / driver seated		Rider Counterbalanced	Rider Counterbalanced	Rider Counterbalanced	Rider Counterbalanced
	1.5	Load capacity / rated load	lbs(kg)	4000 (2000)	5000 (2500)	6000 (3000)	6600 (3300)
	1.6	Load center distance	in(mm)	24 (500)	24 (500)	24 (500)	24 (500)
	1.8	Load center distance, center of drive axle to fork face	in(mm)	18.3 (465)	18.3 (465)	18.7 (475)	8.9 (480)
	1.9	Wheelbase	in(mm)	63.8 (1620)	63.8 (1620)	66.9 (1700)	66.9 (1700)
	Weight	2.1	Service weight	lbs(kg)	7769 (3524)	8552 (3879)	9343 (4238)
2.2		Axle loading, loaded front / rear	lbs(kg)	9281 (4210)/ 1971 (894)	10776 (4888)/ 2361 (1071)	12687 (5755)/ 2343 (1063)	13944 (6325)/ 2207 (1001)
2.3		Axle loading, unloaded front / rear	lbs(kg)	3609 (1637)/ 4160 (1887)	3351 (1520)/ 5200 (2359)	3653 (1657)/ 5690 (2581)	3759 (1705)/ 6043 (2741)
Tires	3.1	Tyre type, P = pneumatic, SE = solid pneu. C = cushion		P	P	P	P
	3.2	Tyre size, front	in	7.00x12 - 14PR	7.00x12 - 14PR	28x9x15 - 14PR	28x9x15 - 14PR
	3.3	Tyre size, rear	in	6.00x9 - 10PR	6.00x9 - 10PR	6.50x10 - 12PR	6.50x10 - 12PR
	3.5	Wheels, number front/rear (x = drive wheels)		2x/2	2x/2	2x/2	2x/2
	3.6	Tread, front	in(mm)	39.2 (996)	39.2 (996)	40.5 1029	40.5 1029
	3.7	Tread, rear	in(mm)	35.6 (904)	35.6 (904)	35.6 (904)	35.6 (904)
	Dimensions	4.1	Tilt of upright / fork carriage, back / forward, a / b	degrees	10/6	10/6	10/6
4.2		Height, upright lowered	in(mm)	85.3 (2165)	85.3 (2165)	85.9 (2180)	85.9 (2180)
4.3		Freelift	in(mm)	4.3 (110)	4.3 (110)	4.3 (110)	4.5 (115)
4.4		Lift height	in(mm)	126 (3195)	126 (3195)	126 (3195)	125 (3165)
4.5		Height, upright extended	in(mm)	153 (3897)	153 (3897)	156 (3967)	154 (3903)
4.7		Height overheadguard	in(mm)	85.4 (2170)	85.4 (2170)	85.8 (2180)	85.8 (2180)
4.8		Seat height	in(mm)	44.8 (1139)	44.8 (1139)	44.8 (1139)	44.8 (1139)
4.12		Coupling height	in(mm)	14.2 (360)	14.2 (360)	14.2 (360)	14.2 (360)
4.19		Overall length	in(mm)	143.8 (3653)	147.5 (3747)	151.8 (3857)	153.3 (3895)
4.20		Length to face of forks	in(mm)	101.7 (2583)	105.4 (2677)	109.7 (2787)	111.2 (2825)
4.21		Width	in(mm)	46.7 (1185)	46.7 (1185)	49.2 (1250)	49.2 (1250)
4.22		Fork dimensions	in(mm)	1.75x4x42 (45x100x1070)	1.75x4x42 (45x100x1070)	1.75x4.8x42 (45x122x1070)	2.0x4.8x42 (50x122x1070)
4.23		Fork carriage		Hook Type	Hook Type	Hook Type	Hook Type
4.24		Fork carriage width	in(mm)	41.0 (1041)	41.0 (1041)	41.0 (1041)	45 (1143)
4.31		Ground clearance minimum, loaded	in(mm)	5.3 (135)	5.3 (135)	5.9 (150)	5.9 (150)
4.32		Ground clearance center of wheelbase	in(mm)	6.1 (155)	6.1 (155)	6.5 (165)	6.5 (165)
4.34		Right Angle Stack (add load length and clearance)	in(mm)	108.5 (2755)	112.0 (2845)	116.3 (2955)	117.7 (2990)
4.35	Outside turning radius	in(mm)	90.2 (2290)	93.7 (2380)	97.6 (2480)	98.8 (2510)	
4.36	Inside turning radius	in(mm)	9.2 (233)	9.2 (233)	8.9 (227)	10.4 (264)	
Performance	5.1	Travel speed loaded/unloaded	mph (kph)	10.3 (16.5)/ 11.2 (18)	10.3 (16.5)/ 11.2 (18)	11.1 (17.9)/ 11.9 (19.1)	11.1 (17.8)/ 11.8 (19.0)
	5.2	Lift speed loaded/unloaded	fpm(ms)	96.5 (0.49)/ 102.4 (0.52)	96.5 (0.49)/ 102.4 (0.52)	94.5 0.48/ 102.4 (0.52)	100.4 0.51/ 110.2 (0.56)
	5.3	Lowering speed loaded/unloaded	fpm(ms)	106.3 (0.54)/ 98.4 (0.50)	106.3 (0.54)/ 98.4 (0.50)	106.3 (0.54)/ 98.4 (0.50)	98.4 (0.50)/ 84.6 (0.43)
	5.6	Max. drawbar pull loaded/unloaded ¹	lbs(N)	4458 (19830) 2147 (9550)	4436 (19732) 2053 (9132)	4738 (21076) 2443 (10867)	4612 (20515) 2335 (10387)
	5.8	Max. gradeability loaded/unloaded ¹	%	43.0 /24.0	33.0 / 21.0	29.0 / 22.6	24.5 / 19.5
Drive Line	5.10	Service brake		Wet Disc	Wet Disc	Wet Disc	Wet Disc
	7.1	Manufacturer / Type		PSI	PSI	PSI	PSI
	7.2	Rated output acc. to SAE J 1349	HP/kW @ rpm	65.3 (48.7)	65.3 (48.7)	65.3 (48.7)	65.3 (48.7)
	7.3	Rated speed	rpm	2500	2500	2500	2500
7.4	No. of cylinders / displacement	# / cu. in. (Liters)	4/144(2.4)	4/144(2.4)	4/144(2.4)	4/144(2.4)	
8.2	Operating pressure for attachments	psi/bar	Adjustable	Adjustable	Adjustable	Adjustable	
8.4	Sound level, driver's ear	dB(A)	79	79	79	79	

Notes: ¹ Assumes Traction Coefficient of .6

STANDARD DIMENSIONS: GTS 20/25/30/35

1.1	Manufacturer	CLARK	CLARK	CLARK	CLARK
1.2	Manufacturer's Designation	GTS20D	GTS25D	GTS20D	GTS33D
1.3	Drive unit Diesel, L.P. Gas	Diesel	Diesel	Diesel	Diesel
1.4	Operator type stand on / driver seated	Rider Counterbalanced	Rider Counterbalanced	Rider Counterbalanced	Rider Counterbalanced
1.5	Load capacity / rated load	4000 (200)	5000 (2500)	6000 (3000)	6600 (3300)
1.6	Load center distance	24 (500)	24 (500)	24 (500)	24 (500)
1.8	Load center distance, center of drive axle to fork face	18.3 (465)	18.3 (465)	18.7 (475)	18.9 (480)
1.9	Wheelbase	63.8 (1620)	63.8 (1620)	66.9 (1700)	66.9 (1700)
2.1	Service weight	7866 (3568)	8505 (3858)	9453 (4288)	9806 (9806)
2.2	Axle loading, loaded front / rear	10617 (4816)/ 1658 (752)	12048 (5465)/ 1969 (893)	14013 (6356)/ 2055 (932)	15181 (6886)/ 1900 (862)
2.3	Axle loading, unloaded front / rear	3589 (1628)/ 4277 (1940)	3269 (1483)/ 5236 (2375)	3644 (1653)/ 5809 (2635)	3713 (1684)/ 6094 (2764)
3.1	Tyre type, P = pneumatic, SE = solid pneu. C = cushion	P	P	P	P
3.2	Tyre size, front	7.00x12 - 14PR	7.00x12 - 14PR	28x9x15 - 14PR	28x9x15 - 14PR
3.3	Tyre size, rear	6.00x9 - 10PR	6.00x9 - 10PR	6.50x10 - 12PR	6.50x10 - 12PR
3.5	Wheels, number front/rear (x = drive wheels)	2x/2	2x/2	2x/2	2x/2
3.6	Tread, front	39.2 (996)	39.2 (996)	40.5 (1029)	40.5 (1029)
3.7	Tread, rear	35.6 (904)	35.6 (904)	35.6 (904)	35.6 (904)
4.1	Tilt of upright / fork carriage, back / forward, a / b	10/6	10/6	10/6	10/6
4.2	Height, upright lowered	85.3 (2165)	85.3 (2165)	85.9 (2180)	85.9 (2180)
4.3	Freelift	4.3 (110)	4.3 (110)	4.3 (110)	4.5 (115)
4.4	Lift height	126 (3195)	126 (3195)	126 (3195)	125 (3165)
4.5	Height, upright extended	153 (3897)	153 (3897)	156 (3967)	154 (3903)
4.7	Height overheadguard	85.4 (2170)	85.4 (2170)	85.8 (2180)	85.8 (2180)
4.8	Seat height	44.8 (1139)	44.8 (1139)	44.8 (1139)	44.8 (1139)
4.12	Coupling height	14.2 (360)	14.2 (360)	14.2 (360)	14.2 (360)
4.19	Overall length	143.8 (3653)	147.5 (3747)	151.8 (3857)	153.3 (3895)
4.20	Length to face of forks	101.7 (2583)	105.4 (2677)	109.7 (2787)	111.2 (2825)
4.21	Width	46.7 (1185)	46.7 (1185)	49.2 (1250)	49.2 (1250)
4.22	Fork dimensions	1.75x4x42 (45x100x1070)	1.75x4x42 (45x100x1070)	1.75x4.8x42 (45x122x1070)	2.0x4.8x42 (50x122x1070)
4.23	Fork carriage	Hook Type	Hook Type	Hook Type	Hook Type
4.24	Fork carriage width	41.0 (1041)	41.0 (1041)	41.0 (1041)	45 (1143)
4.31	Ground clearance minimum, loaded	5.3 (135)	5.3 (135)	5.9 (150)	5.9 (150)
4.32	Ground clearance center of wheelbase	5.9 (150)	5.9 (150)	6.5 (165)	6.5 (165)
4.34	Right Angle Stack (add load length and clearance)	108.5 (2755)	112.0 (2845)	116.3 (2955)	117.7 (2990)
4.35	Outside turning radius	90.2 (2290)	93.7 (2380)	97.6 (2480)	98.8 (2510)
4.36	Inside turning radius	9.2 (233)	9.2 (233)	8.9 (227)	10.4 (264)
5.1	Travel speed loaded/unloaded	13.1 (21.1)/ 14 (22.5)	12.9 (20.7)/ 13.9 (22.4)	13.8 (22.2)/ 14.7 (23.6)	14.7 (23.7)/ 15.5 (24.9)
5.2	Lift speed loaded/unloaded	104.3 (.53)/ 108.3 (.55)	102.4 (.52)/ 108.3 (.55)	98.4 (.50)/ 108.3 (.55)	88.6 (.45)/ 98.4 (.50)
5.3	Lowering speed loaded/unloaded	106.3 (.54)/ 98.4 (.50)	106.3 (.54)/ 98.4 (.50)	106.3 (.54)/ 98.4 (.50)	98.4 (.50)/ 84.6 (.43)
5.6	Max. drawbar pull loaded/unloaded ¹	4744.3 (2152) 1814.4 (823)	4777.4 (2167) 1717.4 (779)	4358.5 (1977) 1525.6 (692)	3988.2 (1809) 1803.4 (818)
5.8	Max. gradeability loaded/unloaded ¹	42.8 / 23.1	36.6 / 20.1	29.0 / 17.1	23.3 / 17.5
5.10	Service brake	Wet Disc	Wet Disc	Wet Disc	Wet Disc
7.1	Manufacturer / Type	ISUZU 4LE2X	ISUZU 4LE2X	ISUZU 4LE2X	ISUZU 4LE2X
7.2	Rated output acc. to SAE J 1349	61.7 (46)	61.7 (46)	61.7 (46)	61.7 (46)
7.3	Rated speed	2400	2400	2400	2400
7.4	No. of cylinders / displacement	4/133(2.2)	4/133(2.2)	4/133(2.2)	4/133(2.2)
8.2	Operating pressure for attachments	Adjustable	Adjustable	Adjustable	Adjustable
8.4	Sound level, driver's ear	81	81	81	81

Upright Table

Maximum Fork Height		Overall Height ¹ Lowered		Free Lift ⁴		Standard Tilt Spec ² B°/F°
in	mm	in	mm	in	mm	
GTS20/25 Standard						
• 130	3300	87.3	2218	4.3	110	10/6
• 146	3725	96.6	2455	4.3	110	10/6
• 152	3860	99.6	2530	4.3	110	10/6
GTS30 Standard						
• 130	3300	87.9	2233	4.3	110	10/6
• 146	3725	97.2	2470	4.3	110	10/6
• 152	3860	100.2	2545	4.3	110	10/6
GTS33 Standard						
• 125	3165	85.8	2180	4.5	115	10/6
• 141	3590	97.2	2470	4.5	115	10/6
• 147	3725	100.1	2545	4.5	115	10/6
GTS20/25 Triple³						
• 189	4800	85.2	2165	37.2	946	5/6
• 205	5210	90.7	2305	42.7	1086	5/3
• 217	5520	96.6	2455	48.6	1236	5/3
GTS30 Triple³						
• 189	4800	85.8	2180	37.8	961	5/6
• 205	5210	91.3	2320	43.3	1101	5/3
• 217	5520	97.2	2470	49.2	1251	5/3
GTS30 Triple³						
• 182	4620	85.8	2180	35.8	911	5/6
• 198	5030	91.3	2320	43.3	1101	5/3
• 210	5340	97.2	2470	49.2	1251	5/3
GTS20/25 Hi-Lo						
• 128	3255	85.2	2165	37.2	946	5/6
• 139	3530	90.7	2305	42.7	1086	5/6
• 148	3760	96.6	2455	48.6	1236	5/6
GTS30 Hi-Lo						
• 128	3255	85.8	2180	37.8	961	5/6
• 139	3530	91.3	2320	43.3	1101	5/6
• 148	3760	97.2	2470	49.2	1251	5/6



CLARK Parts is the ultimate solution for your material handling product needs. CLARK Parts Genuine Replacement parts ensure your Built to Last CLARK forklift stays that way, maintaining the highest quality standards in the industry. Our state-of-the-art parts warehouse in Louisville, KY contains thousands of parts, in stock and ready to ship when needed. With same-day shipping on most orders and coast-to-coast LTL coverage in 3-4 days, CLARK Parts ensures our dealers can quickly service customers' forklifts to reduce costly downtime. With a wide selection — from forks to tires to service supplies — available, CLARK Parts ensures dealers can provide full-service coverage for all their customer needs. Plus, with our exceptional customer service and competitive pricing, you can rest assured that you're getting the best value for your investment.

Notes

Production engines and driveline components may vary in output and/or efficiency by ±5%. The performance shown represents nominal values which may be obtained under typical operating conditions of a machine.

GTS

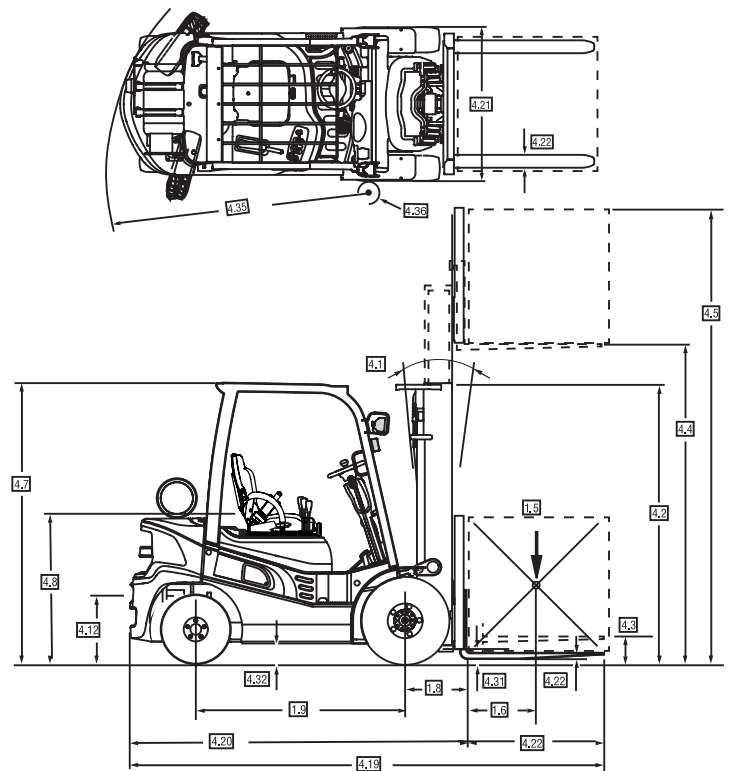



CLARK: The Innovative and Durable Solution

The design, development, and manufacturing capabilities of CLARK, in combination with an unparalleled focus on customer support, a drive to understand fully each customer's needs in order to then supply the right solution, reflect the key essence of what is CLARK.

With over one million CLARK lift trucks sold around the world, each is a testament to the CLARK time-tested process of designing durable trucks with precise features that meet, if not exceed, the material handling needs of our customers. Our full range of dependable products – from pallet jacks to electric narrow aisle order selectors and up to our big 18,000lb capacity lift trucks – assures end-users CLARK has the solutions for their day-to-day needs.



These solutions built from industry innovations, from the nested I-Beam to a self-activating parking brake to new on-board diagnostics, began the same way: with the needs of our customers foremost in mind. By focusing on how we can improve our customers' material handling processes, we can assure our customers a lift truck designed to be the right solution for their needs.

When you bring it all together – an extensive research and development process, state-of-the-art manufacturing capabilities, and a superior dealership network – you have a company dedicated to delivering leading edge products for both today and far into the future. More reasons why CLARK is Built to Last®.



Scan code for more information on this product.

"CLARK, TOTALIFT, Pownworker, PartsPRO Plus, and Built to Last are registered in the U.S Patent and Trademark office. The "Hot Yellow Green" also known as "CLARK Green" is a trademark registered in the U.S Patent and Trademark office."



59-894-0346



CLARK MATERIAL HANDLING COMPANY
North American Headquarters
700 Enterprise Drive • Lexington, KY 40510
866-252-5275 • www.clarkmhc.com

GTS20/25/30/33
59-894-0346 Printed in USA OTP0904125
© 2021 CLARK Material Handling Company