

CLARK

CTX

40/70

100 YEARS OF MATERIAL HANDLING INNOVATION

A Centennial is an important milestone which not only celebrates longevity, but testifies to the strength of the CLARK brand across generations. This is reflected in the more than one million lift trucks manufactured by CLARK Material Handling Company over the past 100 years. Even more powerful than the number of trucks built is the company's legacy of innovation. It began in 1917 when employees of the CLARK Equipment Company constructed a simple three-wheeled shop buggy to haul sand and castings between buildings at their Buchanan, Michigan plant. The "Trutractor", as the shop buggy was named,



became the first internal combustion material handling truck and a great success. The industrial truck was born and in the process CLARK developed the first hydraulic lift. Through the years, many extraordinary inventions followed, among them the nested I-beam upright, overhead guard and operator restraint system. The founding principles of Eugene B. Clark are still true: "Aim always to build the best; never be content with just as good". Today the company remains focused on a bright future and the technologies and trends driving the material handling industry around the world. One Purpose, One Brand, One Legacy, One Century.



CLARK MATERIAL HANDLING COMPANY
 North American Headquarters
 700 Enterprise Drive • Lexington, KY 40510
 866-252-5275 • www.clarkmhc.com



59-894-0997



To Find Your Nearest Authorized
 CLARK Dealer, Visit Our Website
www.clarkmhc.com

CTX40/70

Printed in USA • OTP042215
 © 2022 CLARK Material Handling Company

Max Tow Capacity
 8800 / 15,400 lbs..
 (4000 / 7000 kg)

CLARK



100% AC

48 Volt

The CLARK designed **AC Drive System** uses an enclosed, brushless motor to reduce downtime, and **increase ROI.**

The **100% AC** 48-Volt high performance drive system, and regenerative braking, give the compact rear-wheel drive CTX exceptional **acceleration, speed, and gradeability.**

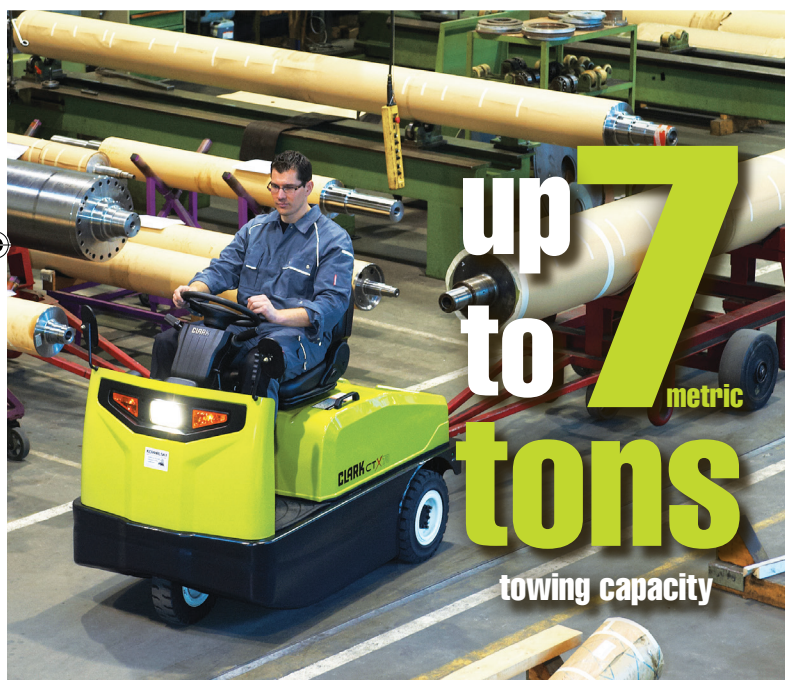

up to 7 metric tons
towing capacity



Smooth Control + Easy Entry/Exit = **Optimal Ergonomics & Product Integrity**

- 26° Tilt Steering Column maximizes operator's driving preferences.
- Automotive style pedal, column, and dash instrumentation.
- Fully Adjustable, Full Suspension seat reduces fatigue to increase driver productivity.

**optional equipment shown on truck.*



- Clamshell hood
 - One-step floorboard removal
 - Centralized fuse box & relay panel
 - Externally mounted drive motor speed sensor
- Allows a qualified service technician quick and full access to major components.



- The CLARK handset can be used for diagnostics and settings of up to 20 different performance parameters to match your requirements.

Highly Maneuverable, Easily Serviceable, Broadly Flexible, Extremely Dependable

The reinforced all steel frame, solid pneumatic tires, large drum brakes, and optional weather enclosure ensures that the CLARK CTX 3-wheel Tow Tractor operates with the same ease of use, flexibility, and rugged durability that has been at the center of CLARK's manufacturing of material handling trucks for nearly 100 years.

DATA / SPECIFICATIONS / DIMENSIONS CTX40/70

Battery Compartment Dimensions
— A-20 SB350 Grey Connector

	Width (W) in mm	Length (L) in mm	Height (H) in mm	Min. Weight lbs kg
CTX 40	32.8 (833)	16.5 (419)	23.2 (589)	882 (400)
CTX 70	32.8 (833)	16.5 (419)	23.2 (589)	1191 (540)

*** All sizes are nominal. Actual batteries must be undersized to allow for clearance for easy install/removal. Recommended battery should be 1/2" - 3/8" less than listed dimensions.

Notes

Performance may vary +5% and -10% due to motor and systems efficiency tolerance. The performance shown represents nominal values which may be obtained under typical operating conditions of a standard machine.

ANSI/ITSDF and Insurance Classification

Standard truck meets all applicable mandatory requirements of Part III-ANSI/ITSDF B56.9 Safety Standard for Operator Controlled Industrial Tow Tractors (latest edition at time of manufacture) and Underwriters Laboratories requirements as to fire and electrical shock hazard only for "E" classification. For further information contact a Clark representative.

Users should be aware of, and adhere to, applicable codes and regulations regarding operator training, use, operation and maintenance of powered industrial trucks, including:

- ANSI/ITSDF B56.9
- NFPA 505, fire safety standard for powered industrial trucks - type designations, areas of use, maintenance and operation.
- Occupational Safety and Health Administration (OSHA) regulations that may apply.

Contact your authorized CLARK forklift truck dealer for further information including operator training programs and auxiliary visual and audible warning systems, fire extinguishers, etc., as available for specific user applications and requirements.

Specifications, equipment, technical data, photos and illustrations are based on information at time of printing and are subject to change without notice. Some products may be shown with optional equipment.

And Don't Forget... Safety Starts With You!

- Before operating a tow tractor, an operator must:**
- Be trained and authorized.
 - Read and understand operator's manual.
 - Not operate a faulty tow tractor.
 - Not repair a tow tractor unless trained and authorized.
- During operation, a tow tractor operator must:**
- Keep entire body inside tractor chassis.
 - Never carry passengers.
 - Keep tractor away from people and obstructions.
 - Allow safe stopping distance and come to a complete stop before leaving operator compartment.
 - Perform daily inspections.
- To park a tow tractor, an operator must:**
- Shift into neutral.
 - Turn key off.
 - Set parking brake.

OPTIONAL EQUIPMENT AVAILABLE:

- AIR TIRES • CLOTH, FULL-SUSPENSION SEAT • WEATHER ENCLOSURE
- BACKUP ALARMS • MIRRORS • INCHING SWITCH w/ CRAWL SPEED BUTTONS
- MULTIPLE HITCH CONFIGURATIONS

			CLARK CTX40	CLARK CTX70		
General Information	1 Manufacturer		CLARK	CLARK		
	2 Model	Manufacturer's Designation	CTX40	CTX70		
	3 Rolling Load Capacity	lbs(kg)	8800 (4000)	15400 (7000)		
	4					
	5 Power Unit	Electric	48 Volt	48 Volt		
	6 Operator Type		Rider	Rider		
	7 Tire Type		Solid Pneumatic	Solid Pneumatic		
	8 Wheels (x-driven)	Front/Rear	1 / 2x	1 / 2x		
Basic Dimensions	15 Overall Dimensions					
	17	Width Over Frame	in(mm)	39.2 (995)	39.2 (995)	
	18	Length w/ Hitch w/o Hitch	in(mm)	72 (1830) / 68 (1730)	72 (1830) / 68 (1730)	
	19	Coupling Height	in(mm)	11.6 (295)	11.6 (295)	
	20	Height, Weather Enclosure	in(mm)	80.1 (2035)	80.1 (2035)	
	21	Step Height	Ground to Top of Step Plate	in(mm)	18.5 (470)	18.5 (470)
	22	Loading Height	Ground to Cargo Area (unloaded)	in(mm)	23.8 (605)	23.8 (605)
		Length of Loading Surface	in(mm)	16.5 (420)	16.5 (420)	
		Width of Loading Surface	in(mm)	30.2 (767)	30.2 (767)	
	23	Turning Radius	Turning Radius	in(mm)	67 (1700)	67 (1700)
24	Inside Turning Radius		in(mm)	21.7 (550)	21.7 (550)	
25	Overhang	Center of Rear Axle to Face of rear bumper	in(mm)	12.2 (310)	12.2 (310)	
26	Seat Height	Ground to top of Seat Cushion	in(mm)	36.2 (920)	36.2 (920)	
27						
Performance	28	Speeds	Travel Speed, Max w/ Load	mph(kph)	5.6 (9)	4.3 (7)
	29		Travel Speed, Max w/o Load	mph(kph)	8.1 (13)	10.6 (17)
	30					
Weights	31					
	34	Service Weight	lbs(kg)	2006 (910)	2315 (1050)	
Chassis	35	Axle loading	Unload, Front / Rear	lbs(kg)	860 (390) / 1147 (520)	948 (430) / 1367 (620)
			Unloaded, Rear	lbs(kg)	1146 (520)	1367 (620)
	39	Tires	Number, Front/Rear		1/2	1/2
Drive Line	40		Size, Front	in(mm)	4.0 (8)	4.0 (8)
			Size, Rear	in(mm)	4.0 (8)	4.0 (8)
	41	Wheelbase		in(mm)	45.6 (1160)	45.6 (1160)
	42	Track	Rear	in(mm)	34.25 (870)	34.25 (870)
	43					
	44	Ground Clearance	At Center of Wheelbase	in(mm)	3.54 (90)	3.54 (90)
Drive Line	45	Drive Motor Rating	S2-60m	HP(kW)	8 (6.0)	8 (6.0)
	46	Service Brake			Regen / Drum & Shoe	Regen / Drum & Shoe
	48	Battery	Type		Lead-Acid	Lead-Acid
			Weight, Min	lbs(kg)	882 (400)	1191 (540)
		Drive Motor Control		AC Inverter	AC Inverter	
		Max Capacity (6 hr rated)	kWh	14.0	14.0	
57	Towing Coupling, Type			Pin Type	Pin Type	
58	Sound Level	Avg. at Operator's Ear Per ANSI B56.11.5	dB(A)	68.4	69.5	

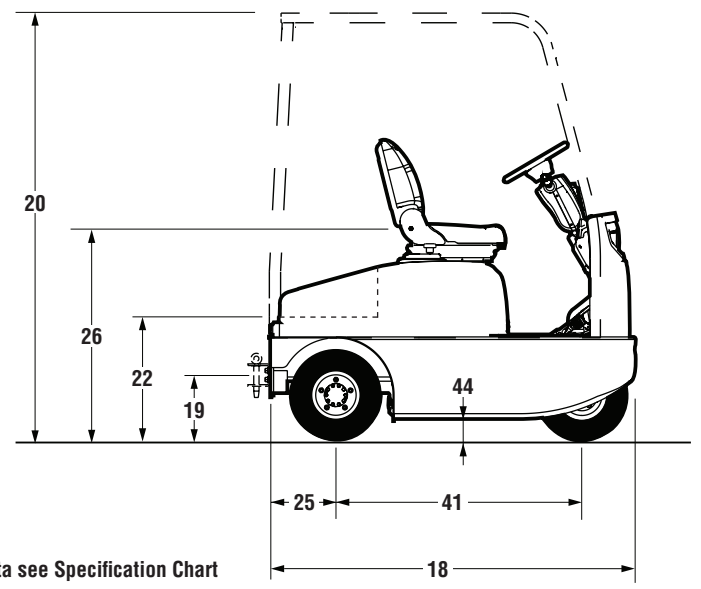
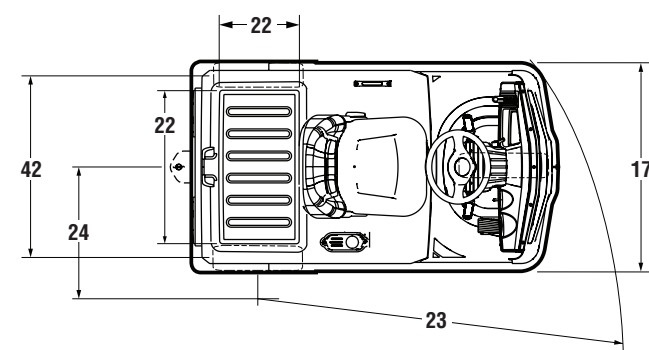

For corresponding data see Specification Chart