



Operator's Manual

ESX 12-25

OM-718

IMPORTANT! Do not remove this manual from the lift truck.

MAR 2023 | REV 1.2

Record the following information pertaining to your truck.

Model No. _____

Serial No. _____

Customer Truck Identification No. _____

Truck Weight, Empty _____

Truck Rated Capacity _____

Truck Gross Weight _____

Special Equipment or Attachments _____

IMPORTANT
Do not expose this manual to hot water or steam.

Index

A

- A Message to Operators..... ii
- Adjusting the load forks 5.10
- Air cleaning the truck..... 6.22
- After operating 5.16
- Attachments.....3.11
- Auxiliary controls 3.9

B

- Battery 6.23
- Charging..... 6.25
 - Cleaning and care 6.27
 - Handling 6.24
 - Installation 6.28
 - Maintenance 6.23
 - Maximum battery life 6.27
 - Removal from truck 6.26
 - Service records..... 6.27
- Before Operating the Truck .. 5.2
- Brakes 6.17
- Braking 5.6

C

- Capacity of truck..... 1.10
- Capacity plate.....3.11
- Chain slack 2.7
- Classified area 5.8
- Contents of Manualv
- Controlling speed..... 5.6

D

- Daily inspection 1.2 & 4.2
- Data plate3.11
- Decals
 - Keep away from forks 3.13
 - Safety warning 3.12
 - Upright warning..... 3.13
 - Diagnostic display, using... 5.4
- Diagnostic display..... 6.16
- Do's and Don'ts 1.3
- Driver's Daily Checklist..... 1.2

F

- Fault codes, operator 3.5
- Forks 6.14
- Forks and upright,
positioning 5.5 & 5.10
- Fork wear and damage 6.14
- Function change button..... 3.7
- Functional checks..... 4.4
- Functional tests 6.15

G

- General Safety Rules 1.1

H

- Horn button..... 3.7
- Hour reading, digital 3.5
- How to Use Manual viii
- Hydraulic fluid 6.21
- Hydraulic fluid pressure..... 6.12
- Hydraulic leaks 4.2

I

- Intervals..... 6.8 & 6.9
- Introduction.....vi

J

- Jacking and blocking 6.4

K

- Keep away from forks decal 3.13
- Key/start switch 3.4

L

- Lateral Tip Over 1.12
- Lift chain 6.13
- Load handling 5.10
- Longitudinal Tip-over 1.12
- Long loads 2.3
- Loose loads 2.2

M
Major component location 6.7
Moving Loads 5.12
Multi-Function Handle 3.6

N
No Riders..... 1.4

O
Operator Daily Inspection vii
Operating procedures..... 3.1
Operating Safely..... 5.7
Operating the Truck, After... 5.16
Operator's Manual 5.2
Operator's Manual holder 5.2
Operator's position 3.3
Out of service tag 4.5
Overhead clearance 2.4
Overhead guard..... 1.6 & 3.2

P
Pallets..... 2.8
Parking 4.4 & 5.16
Parking brake 3.10
Pedestrians..... 1.5
Picking up loads 5.12
Planned Maintenance..... vii, 6.1
Plugging..... 3.10 & 5.6

R
Recommended PM Intervals 6.8
Reporting problems 4.2
Riders 1.4 & 5.7
Right-angle stacking..... 2.6
Routine Servicing vi

S
Safety inspection, daily..... 1.2
Safety, operating safely 5.7

Safety plates and decals. See
Decals and safety plates
Safety Sign and Messages.....x
Safety rules..... 1.1
Skids..... 2.8
Specifications 7.1
Stability 5.5, 5.8 & 5.10
Stacking..... 5.14
Starting from a safe condition5.3
Surface and Capacity 1.10
Surface, hazards 1.10

T
Tilt restriction indicator..... 3.8
Tip Over..... 1.12 & 1.13
Traveling with a load.....5.11
Turning 5.8
Type designation 5.8 & 5.9

U
Unloading 5.13
Upright warning decal..... 3.13

V
Variable tilt feature..... 3.8
Vertical Mast..... 3.9
Visual Checks..... 4.3
Visual checks, by operator ... 4.3

W
What to do in Case of a
Tip-over 1.13
Wide loads..... 2.2

Operator's Manual

You must be trained and authorized to operate a lift truck.

YOU can prevent accidents

First: Learn safe operating rules and your company rules.

Next: Read your Operator's Manual. If you do not understand it, ask your supervisor for help.

Learn about the unit you operate.

KNOW YOUR TRUCK

Then: Practice operating your truck safely.

And: Keep your truck in safe operating condition with correct and timely maintenance.

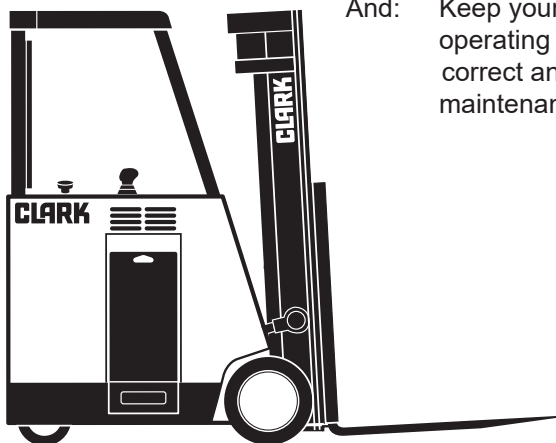

Breaking these rules will cause serious or fatal injury to yourself and others



A Message to CLARK Lift Truck Operators

Lift trucks are specialized machines with unique operating characteristics, designed to perform a specific job. Their function and operation is not like a car or ordinary truck. They require specific instructions and rules for safe operation and maintenance.

Safe operation of lift trucks is of primary importance to CLARK. Our experience with lift truck accidents has shown that when accidents happen and people are killed or injured, the causes are:

- **Operator not properly trained**
- **Operator not experienced with lift truck operation**
- **Basic safety rules not followed**
- **Lift truck not maintained in safe operating condition**

For these reasons, CLARK wants you to know about the safe operation and correct maintenance of your lift truck.

This manual is designed to help you operate your lift truck safely. This manual shows and tells you about safety inspections and the important general safety rules and hazards of lift truck operation. It describes the special components and features of the truck and explains their functions. The correct operating procedures are shown and explained. Illustrations and important safety messages are included for clear understanding. A section on maintenance and lubrication is included for the lift truck mechanic.



The operator's manual is not a training manual. It is a guide to help trained and authorized operators safely operate their lift truck by emphasizing and illustrating the correct procedures. However, it cannot cover every possible situation that may result in an accident. You must watch for hazards in your work areas and avoid or correct them. It is important that you know and understand the information in this manual and that you know and follow your company safety rules! Be sure that your equipment is maintained in a safe condition. Do not operate a damaged or malfunctioning truck. Practice safe operation every time you use your lift truck. Let's join together to set high standards in safety.

Remember, before you start operating this lift truck, be sure you understand all driving procedures. It is your responsibility, and it is important to you and your family, to operate your lift truck safely and efficiently. Be aware that the Federal Occupational Safety and Health Administration (OSHA) and state laws require that operators be completely trained in the safe operation of lift trucks; it is also an OSHA requirement that a machine inspection be performed before every shift. If you think you need training in operating or inspecting your lift truck, ask your supervisor.

CLARK lift trucks are built to take hard work, but not abuse. They are built to be dependable, but they are only as safe and efficient as the operator and the persons responsible for maintaining them. Do not make any repairs to this truck unless you have been trained in safe lift truck repair procedures and are authorized by your employer.





Contents of this Manual

A Message to CLARK Lift Truck Operators.....	ii
Introduction.....	vi
How to Use this Manual	viii
Safety Signs and Safety Messages	x
Section 1. General Safety Rules.....	1-1
Section 2. Operating Hazards.....	2-1
Section 3. Common Truck.....	3-1
Section 4. Operator Maintenance and Care	4-1
Section 5. Operating Procedures	5-1
Section 6. Planned Maintenance	6-1
Section 7. Specifications	7-1
Index	Index-1



Introduction

CLARK welcomes you to the growing group of professionals who own, operate, and maintain CLARK lift trucks. We take pride in the long tradition of quality products and superior value the CLARK name represents. This manual familiarizes you with safety, operating, and maintenance information about your new lift truck. It has been specially prepared to help you use and maintain your CLARK lift truck in a safe and correct manner.

Your CLARK lift truck has been designed and built to be as safe and efficient as today's technology can make it. As manufactured, it meets all the applicable mandatory requirements of ANSI B56.1 Safety Standard for Powered Industrial Trucks. Each truck is also furnished with equipment to help you operate safely; for example, load back rest, parking brake and horn are standard equipment.

Safe, productive operation of a lift truck requires both skill and knowledge on the part of the operator. The operator must know, understand, and practice the safety rules and safe driving and load handling techniques described in this manual. To develop the skill required, the operator must become familiar with the construction and features of the lift truck and how they function. The operator must understand its capabilities and limitations, and see that it is kept in a safe condition.

Routine Servicing and Maintenance

Regular maintenance and care of your lift truck is not only important for economy and utilization reasons; it is essential for your safety. A faulty lift truck is a potential source of danger to the operator, and to other personnel working near it. As with all quality equipment, keep your lift truck in good operating condition by following the recommended schedule of maintenance.



Operator Daily Inspection — Safety and Operating Checks

A lift truck should always be examined by the operator, before driving, to be sure it is safe to operate. The importance of this procedure is emphasized in this manual with a brief illustrated review and later with more detailed instructions. CLARK dealers can supply copies of a helpful “Drivers Daily Checklist.”

Planned Maintenance

In addition to the daily operator inspection, CLARK recommends that a planned maintenance and safety inspection program (PM) be performed by a trained and authorized mechanic on a regular basis. The PM will provide an opportunity to make a thorough inspection of the safety and operating condition of your lift truck. Necessary adjustments and repairs can be done during the PM, which will increase the life of components and reduce unscheduled downtime and increase safety. The PM can be scheduled to meet your particular application and lift truck usage.

The procedures for a periodic planned maintenance program that covers inspections, operational checks, cleaning, lubrication, and minor adjustments are outlined in this manual. Your CLARK dealer is prepared to help you with a Planned Maintenance Program by trained service personnel who know your lift truck and can keep it operating safely and efficiently.

How to Use this Manual

This manual is a digest of essential information about the safe operation, the features and functions and explains how to maintain your lift truck. This manual is organized into eight major parts:

Section 1, General Safety Rules, reviews and illustrates accepted practices for safe operation of a lift truck.

Section 2, Operating Hazards, warns of conditions that could cause damage to the truck or injury to the operator or other personnel.

Section 3, Common Truck, describes the most common operating components, systems, controls, and other features of your truck and tells how they function.

Section 4, Operator Maintenance and Care, presents details on how to perform the operator's daily safety inspection and refuel the lift truck.

Section 5, Operating Procedures, discusses more specific instruction on the safe, efficient operation of your lift truck.

Section 6, Planned Maintenance, describes the PM program.

Section 7, Specifications, provides reference information and data on features, components, and maintenance items.

Also, the **Index** helps you locate information about various topics.

NOTICE: The descriptions and specifications included in this manual were in effect at the time of printing. CLARK Material Handling Company reserves the right to make improvements and changes in specifications or design, without notice and without incurring obligation. Please check with your authorized CLARK dealer for information on possible updates or revisions.

The examples, illustrations, and explanations in this manual should help you improve your skill and knowledge as a professional lift truck operator and take full advantage of the capabilities and safety features of your new lift truck.

The first Section of the manual is devoted to a review, with illustrations and brief messages, of general safety rules and the major operating hazards you can encounter while operating a lift truck. Next, you will find descriptions of the components of your specific lift truck model and how the instruments, gauges, and controls operate. Then, you will find a discussion of safe and efficient operating procedures, followed by



instructions on how to tow a disabled lift truck. The later sections of the manual are devoted to maintenance and truck specifications.

Take time to carefully read the “Know Your Truck” section. By acquiring a good basic understanding of your truck’s features, and how they function, you are better prepared to operate it both efficiently and safely.

In “Planned Maintenance,” you will find essential information for correct servicing and periodic maintenance of your truck, including charts with recommended maintenance intervals and component capacities. Carefully follow these instructions and procedures.

Each major Section has its own table of contents, so that you can find the various topics more easily. If you cannot find a topic in the table of contents, check the index at the back of the manual.

We urge you to first carefully read the manual from cover to cover. Take time to read and understand the information on general safety rules and operating hazards. Acquaint yourself with the various procedures in this manual. Understand how all gauges, indicator lights, and controls function. Please contact your authorized CLARK dealer for the answers to any questions you may have about your lift truck’s features, operation, or manuals.

Operate your lift truck safely; careful driving is your responsibility. Drive defensively and think about the safety of people who are working nearby. Know your truck’s capabilities and limitations. Follow all instructions in this manual, including all IMPORTANT, CAUTION, WARNING, and DANGER messages to avoid damage to your lift truck or the possibility of any harm to yourself or others.

This manual is intended to be a permanently attached part of your lift truck. Keep it on the truck as a ready reference for anyone who may drive or service it. If the truck you operate is not equipped with a manual, ask your supervisor to obtain one and have it attached to the truck. And, remember, your CLARK dealer is pleased to answer any questions about the operation and maintenance of your lift truck and will provide you with additional information should you require it.



Safety Signs and Safety Messages

Improper operation can cause accidents. Don't take chances with incorrect or damaged equipment. **Read** and **understand** the procedures for safe driving and maintenance outlined in this manual. Don't hesitate to ask for help. **Stay alert!** Follow safety rules, regulations, and procedures. Avoid accidents by recognizing dangerous procedures or situations before they occur. **Drive and work safely** and follow the safety signs and their messages on the truck and in this manual.

Safety signs and messages are placed in this manual and on the truck to provide instructions and identify specific areas where potential hazards exist and special precautions should be taken. Know and understand the meaning of these instructions, signs, and messages. Damage to the truck, death, or serious injury to you or other persons may result if these messages are not followed. If warning decals are damaged, they must be replaced. Contact your CLARK dealer for replacements.

NOTICE

This message is used when special information, instructions or identification are required relating to procedures, equipment, tools, pressures, capacities and other special data.

IMPORTANT

This message is used when special precautions should be taken to ensure a correct action or to avoid damage to or malfunction of the truck or a component.



CAUTION

Indicates a potentially hazardous situation which, if not avoided, may result in minor or moderate injury. It may also be used to alert against unsafe practices.



WARNING

Indicates a potentially hazardous situation which, if not avoided, could result in death or serious injury.



DANGER

Indicates an imminently hazardous situation which, if not avoided, will result in death or injury



General Safety Rules

Contents

Daily Inspection	1.2
Do's and Don'ts.....	1.3
No Riders	1.4
Pedestrians	1.5
Operator Protection	1.6
Fork Safety	1.7
Pinch Points	1.8
Travel	1.9
Surface and Capacity	1.10
Grades, Ramps, Slopes, and Inclines.....	1.11
Tip Over	1.12
What to do in Case of a Tip-Over	1.13
Parking.....	1.14



Daily Inspection

CLARK Material Handling Company

OPERATORS' DAILY CHECKLIST
Check Each Item Before Start Of Each Shift

Date: _____

Check one: Gas/LPG/Diesel Truck Electric Sit-down Electric Stand-up Electric Pallet

Truck Serial Number: _____ Operator: _____ Supervisor's OK: _____

Hour meter reading: _____

Check each of the following items before the start of each shift. Let your supervisor and/or maintenance department know of any problem. **DO NOT OPERATE A FAULTY TRUCK.** Your safety is at risk. After checking, mark each item accordingly, Explain below as necessary.

Check boxes as follows: OK NG, needs attention, or repair. Circle problem and explain below

OK	NG	VISUAL CHECKS
<input type="checkbox"/>	<input type="checkbox"/>	Tires/Wheels: wear, damage, nuts tight
<input type="checkbox"/>	<input type="checkbox"/>	Head/Tail Working Lights: damage, mounting, operation
<input type="checkbox"/>	<input type="checkbox"/>	Gauges/Instruments: damage, operation
<input type="checkbox"/>	<input type="checkbox"/>	Operator Restraint: damage, mounting, operation, oily, dirty
<input type="checkbox"/>	<input type="checkbox"/>	Warning Decals/Operators' Manual: missing, not readable
<input type="checkbox"/>	<input type="checkbox"/>	Data Plate: not readable, missing
<input type="checkbox"/>	<input type="checkbox"/>	Overhead Guard: bent, cracked, loose, missing
<input type="checkbox"/>	<input type="checkbox"/>	Load Back Rest: bent, cracked, loose, missing
<input type="checkbox"/>	<input type="checkbox"/>	Forks: bent, worn, stops OK
<input type="checkbox"/>	<input type="checkbox"/>	Engine Oil level: dirty, leaks
<input type="checkbox"/>	<input type="checkbox"/>	Hydraulic Oil level: dirty, leaks
<input type="checkbox"/>	<input type="checkbox"/>	Radiator: fluid level, dirty, leaks
<input type="checkbox"/>	<input type="checkbox"/>	Fuel: level, leaks
<input type="checkbox"/>	<input type="checkbox"/>	Battery: connections loose, charge, electrolyte low
<input type="checkbox"/>	<input type="checkbox"/>	Covers/Sheetmetal: damaged, missing
<input type="checkbox"/>	<input type="checkbox"/>	Brakes: linkage, reservoir fluid level, leaks, debris on floor

OK	NG	OPERATIONAL CHECKS
<input type="checkbox"/>	<input type="checkbox"/>	Engine: runs rough, noisy, leaks
<input type="checkbox"/>	<input type="checkbox"/>	Steering: loose/binding, leaks, operation
<input type="checkbox"/>	<input type="checkbox"/>	Service Brake: linkage loose/binding, stops OK, grab
<input type="checkbox"/>	<input type="checkbox"/>	Parking Brake: loose/binding, operational, adjustment
<input type="checkbox"/>	<input type="checkbox"/>	Seat Brake (if equipped): loose/binding, operational, adjustment
<input type="checkbox"/>	<input type="checkbox"/>	Horn: operation
<input type="checkbox"/>	<input type="checkbox"/>	Backup Alarm (if equipped): mounting, operation
<input type="checkbox"/>	<input type="checkbox"/>	Warning Lights (if equipped): mounting, operation
<input type="checkbox"/>	<input type="checkbox"/>	Lift/Lower: loose/binding, excessive drift, leaks
<input type="checkbox"/>	<input type="checkbox"/>	Tilt: loose/binding, excessive drift, "chatters", leaks
<input type="checkbox"/>	<input type="checkbox"/>	Attachments: mounting, damaged, operation, leaks
<input type="checkbox"/>	<input type="checkbox"/>	Battery Test (electric trucks only): indicator in green while holding full forward tilt
<input type="checkbox"/>	<input type="checkbox"/>	Control Levers: loose/binding, freely return to neutral
<input type="checkbox"/>	<input type="checkbox"/>	Directional Control: loose/binding, find neutral OK

Explanation of problems marked above:

58-770-0937 Jan 1996

At the beginning of each shift, inspect your truck and fill out a daily inspection sheet.

Check for damage and maintenance problems.

Have repairs made before you operate the truck.



CAUTION

DO NOT MAKE REPAIRS YOURSELF. Lift truck mechanics are trained professionals. They know how to make repairs safely (Refer to Section 4).



Do's and Don'ts



OM0001

Don't mix drugs or alcohol with your job.

Do watch for pedestrians.



OM0002



OM0003

Don't block safety or emergency equipment.

Do wear safety equipment when required.



OM0004



OM0005

Don't smoke in "NO SMOKING" areas or when refueling.



No Riders



718001

The operator is the only one who should be on a truck.



WARNING

Never transport personnel on the forks of a lift truck.

Pedestrians

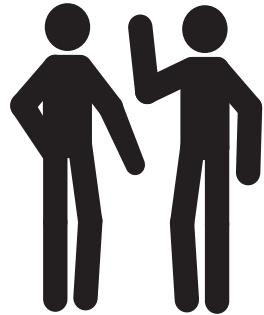

IMPORTANT

- Watch where you are going.
- Look in the direction of travel.
- Pedestrians may use the same roadway you do.
- Sound your horn at all intersections or blind spots.
- Watch for people in your work area even if your truck has warning lights or alarms. People may not watch for you.
- Make people stand back, even when you are parked.

Operator Protection

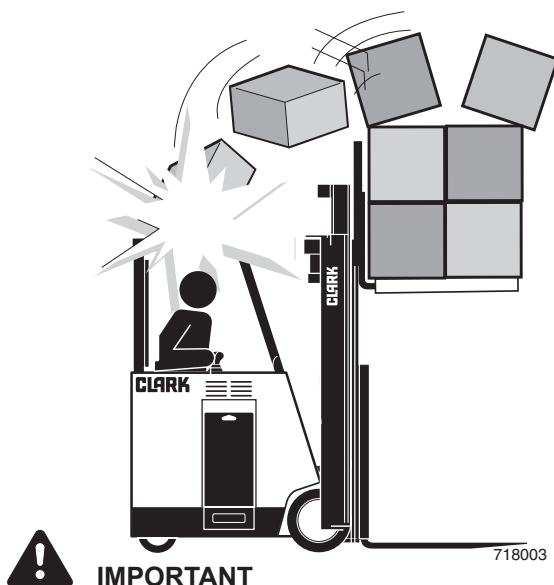

- Keep under the overhead guard.
- Always keep your body within the confines of the truck.
- Be especially careful when traveling in reverse and maneuvering in tight areas.
- Watch for intrusions into the operator compartment.

Keep arms and legs in the operator compartment

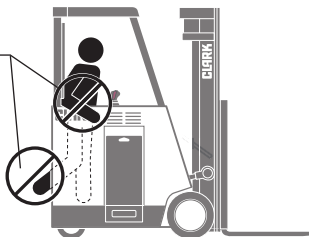

Fork Safety



DANGER

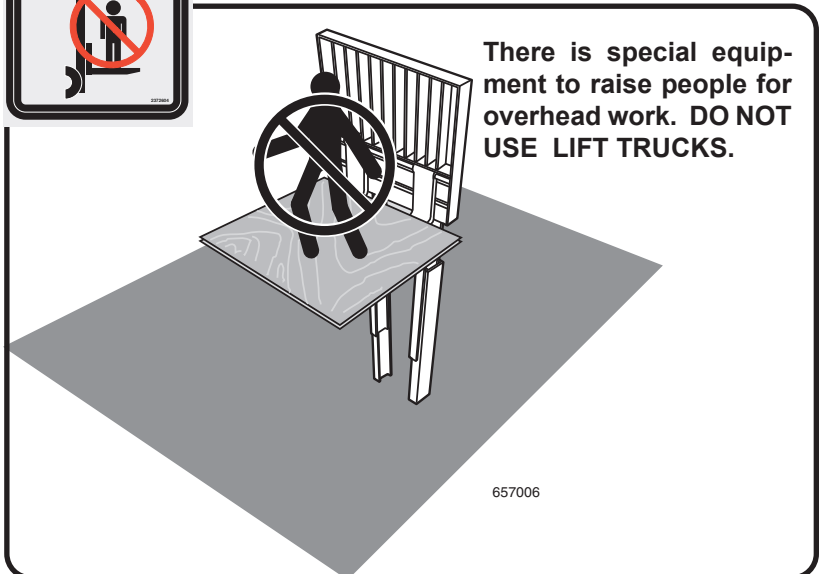

Pinch Points

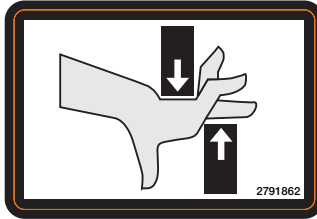

WARNING

Keep hands, feet and legs out of the upright.

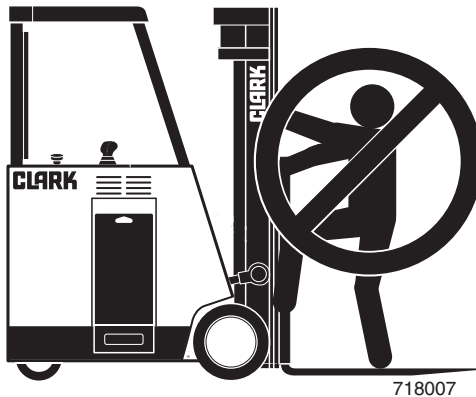

WARNING

Don't use the upright as a ladder.



CAUTION

Never try to repair the upright, carriage, chain, or attachment yourself! Always get a trained mechanic.

Travel

Travel with the load near the floor/ground with forks tilted back to cradle the load whenever possible.

Never lift or lower the load when the truck is in motion.

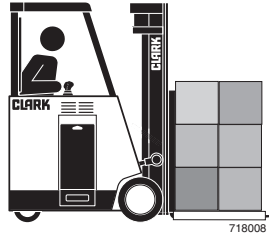

When handling bulky loads that restrict your vision operate your truck in reverse to improve visibility.

Be sure to pivot in the operator compartment to give maximum visibility.

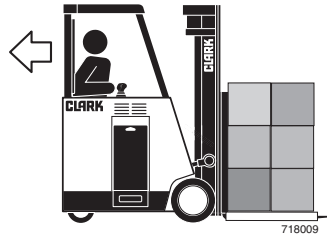

Unstable loads are a hazard to you and to your fellow workers.

Always make certain that the load is well stacked and evenly positioned across both forks.

Never attempt to lift a load with only one fork.

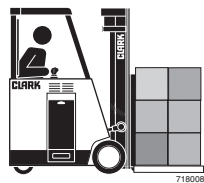

Right



Wrong

Surface and Capacity

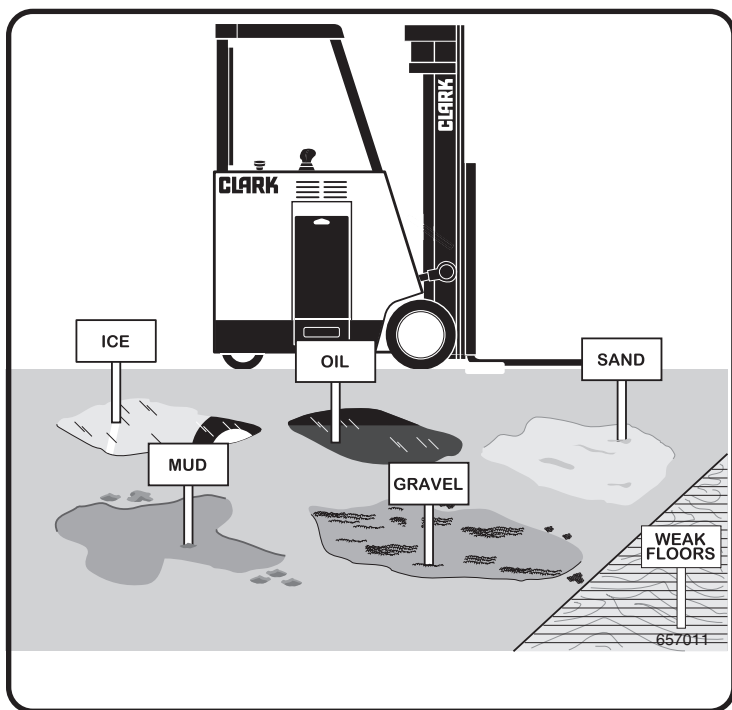

Avoid these conditions. They can cause a truck to tip over or lose traction for braking or driving.



WARNING

Know the weight of your truck and load. Especially when using elevators. Know the capacity of the elevator you intend to use. Do not overload.

Grade, Ramps, Slopes and Inclines

There are five basic points you should practice when operating on grades:

1. Travel up and down grades slowly.
2. Travel straight up and straight down.
3. Without a load, travel up or down with the forks pointing downgrade.



WARNING

Never turn on grades, ramps, slopes or inclines; wait until you are back on level surface.

4. With a load travel up or down with the load pointing upgrade.
5. The load should be tilted back and raised only high as necessary to clear the surface.

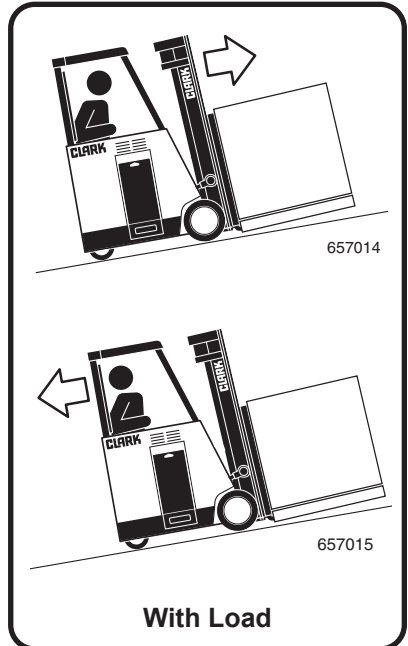
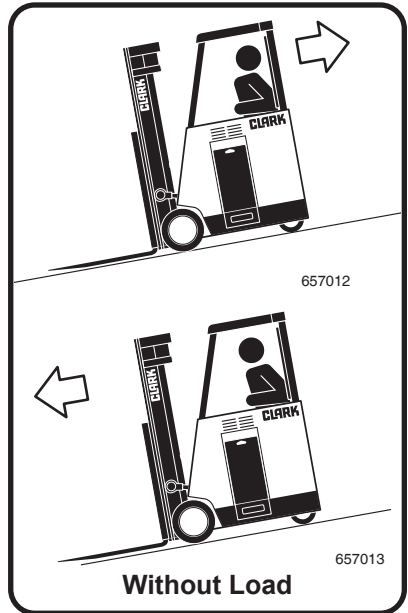

Tip-over

Lateral Tip-over

- Lateral tip-over can occur with a combination of travel speed and sharpness of turn. This combination may exceed the stability of the truck. This condition is even more likely with an unloaded truck.
- While traveling with the load or upright raised, lateral tip-over can occur while turning and/or braking when in reverse or accelerating and turning while traveling forward.
- Lateral tip-over can occur loaded or unloaded by turning on an incline or ramp.



Longitudinal Tip-over

- Longitudinal tip-over can occur with a combination of overloading and load elevated also with capacity load and elevated. Traveling with this combination may exceed the stability of the truck. This condition is even more likely with excessive forward tilt, braking in forward travel or accelerating rearward.
- Longitudinal tip-over can occur by driving with the load down slope on a steep grade.

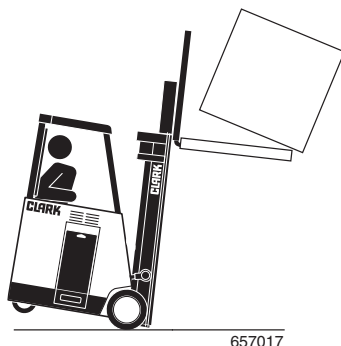

Lateral and longitudinal tip-over can occur if the truck is driven over objects on the floor or ground, off the edge of improved surfaces, or into potholes in the road surface, or by running into overhead objects or collisions.

An off dock type of tip-over can occur if the truck is steered too close to the dock edge, driven off the edge of the dock or ramp, or if the highway truck or trailer rolls away from the dock or is driven away during loading.



WARNING

The conditions listed above can be further aggravated by overloading, excessive tilt, or off center loads.



DANGER

Lift truck tip-over can cause serious injury or death if the operator is trapped between the truck and the ground.



What to do in Case of a Tip-over

If your truck starts to tip over,



DANGER

If your electric stand-up lift truck starts to tip over in any direction, CLARK recommends stepping off and away from the rear of the truck.



IMPORTANT

If you tip an electric stand-up lift truck over, you can be seriously injured, or killed, no matter what you do! Your best chance of surviving a tip over is to get away from the falling truck and load. You must step out and away from the driver's compartment.

NOTE: This only applies to a stand-up rider type truck with a large rear opening in the drivers compartment.

Parking

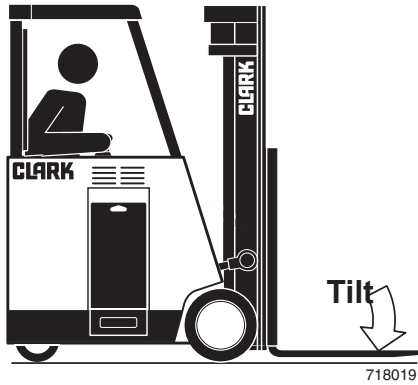

- Always come to a complete stop.
- Park only in authorized locations.
- Never park on a grade.
- Be sure travel control is in NEUTRAL.
- Lower forks fully to floor and tilt forward.
- Turn key to OFF position.
- When you step from the truck or turn the key switch to OFF, the brake will set itself.
- Never step from the truck while it is motion. Always come to a complete stop before leaving the truck. Doing so is not only dangerous, but will cause accelerated wear of the brake components.

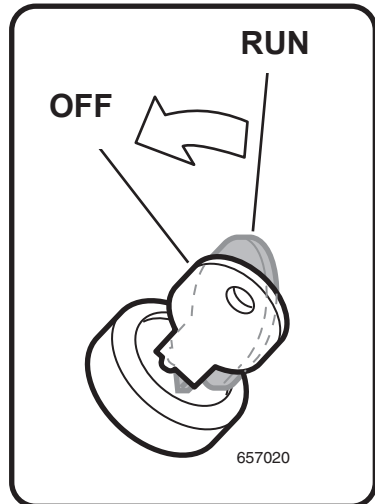

Operating Hazards

Contents

Loose Loads.....	2.2
Long and Wide Loads	2.3
Rear Swing	2.3
Low Overhead Clearance.....	2.4
Fast Turns and High Loads.....	2.4
Docks / Drop-offs	2.5
Right-Angle Stacking	2.6
Chain Slack	2.7
Pallets and Skids	2.8

This Section shows some of the hazards that may cause you, or someone around you, to be killed or badly hurt. As the operator, you must look for other hazards. Get your supervisor to help you identify and avoid those hazards.

Loose Loads



WARNING

Loose or unbalanced loads are dangerous. Observe these precautions.

Never carry loose or uneven material.

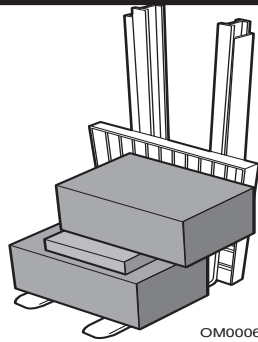

OM0006

Center wide loads.

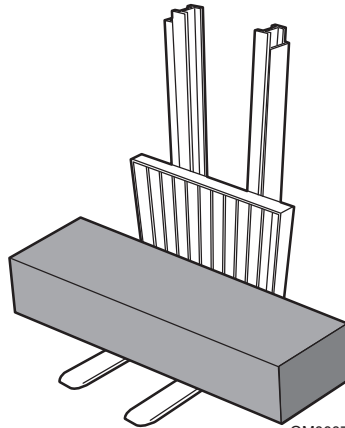

OM0007

Stack and band loose material.

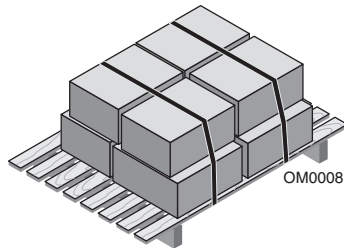

OM0008

Long and Wide Loads / Rear Swing



WARNING

With long or wide loads, you need more room. So slow down and watch your clearance.

A long load reduces the capacity of the truck. Know and understand your truck load rating.

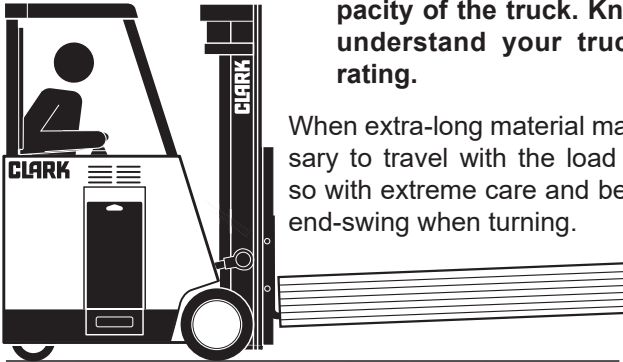

When extra-long material makes it necessary to travel with the load elevated, do so with extreme care and be alert to load end-swing when turning.

718022



WARNING

When turning, be sure the rear end of the truck does not swing into racks, posts, etc. Watch for pedestrians beside the truck.

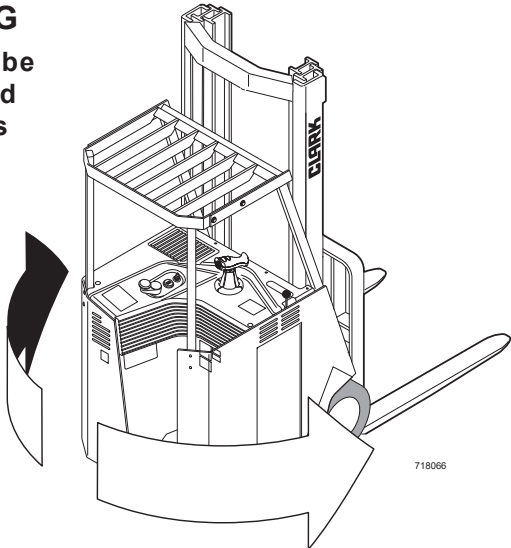

718066

Low Overhead Clearance Fast Turns and High Loads



WARNING

Know the height of your truck, with and without a load.

Check your clearances.

Keep the load low and tilted back.

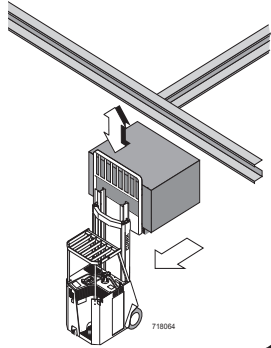

WARNING

Watch overhead clearance.

Moving into overhead structures can tip a truck over, or spill a load.

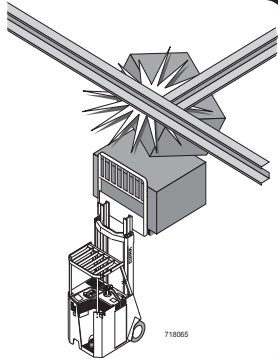

WARNING

Slow down before turning. The truck can tip over.

Turn too sharp with a raised load and your truck can tip even at slow speeds.

Travel with a load raised only when removing or depositing a load.

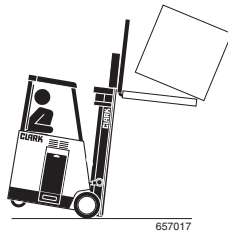

Docks / Drop-offs

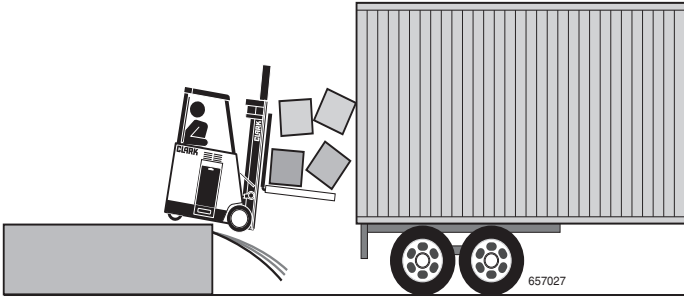

WARNING

To avoid these hazards, you must:

- Talk to the truck driver yourself; make sure the driver does not move the trailer until you are done!
- Apply trailer brakes.
- Use wheel chocks.
- Use trailer-to-dock locking system if available.

The impact of moving in and out of a trailer may cause the trailer to creep or move.

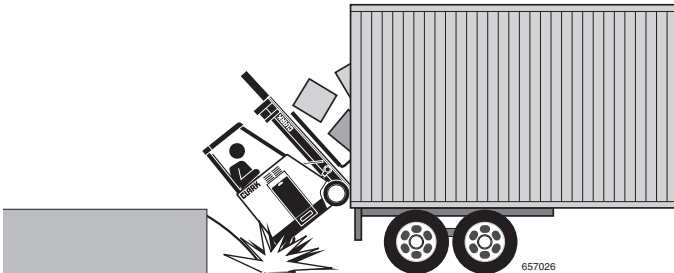

Right-Angle Stacking

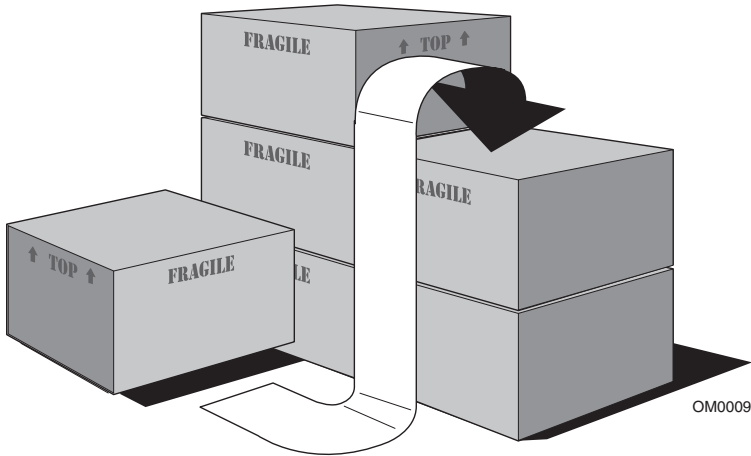

SLOWLY



WARNING

When right-angle stacking or moving with a raised load to clear low objects, avoid sharp turns and move slowly.

Chain Slack

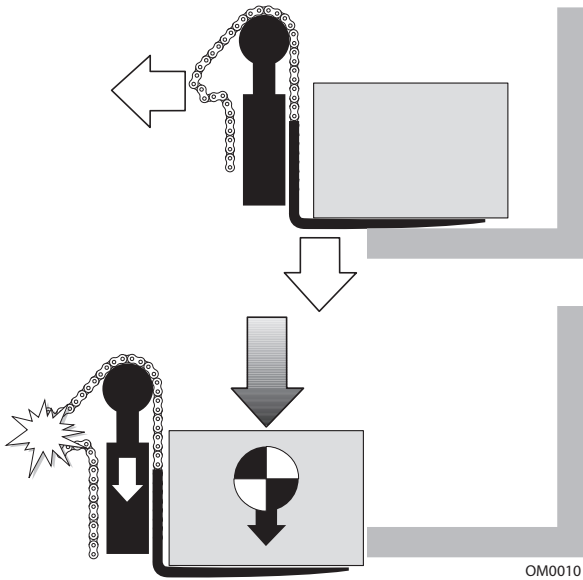

WARNING

Slack chains mean rail or carriage hang-up. Raise the forks before you move, or broken chains and/or hoses can result.

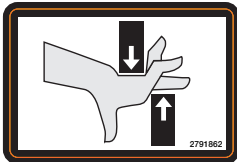

WARNING

Keep hands, feet and legs out of the upright.

WARNING

Don't use the upright as a ladder.

CAUTION

Never try to repair the upright, carriage, chain, or attachment yourself! Always get a trained mechanic.

Pallets and Skids

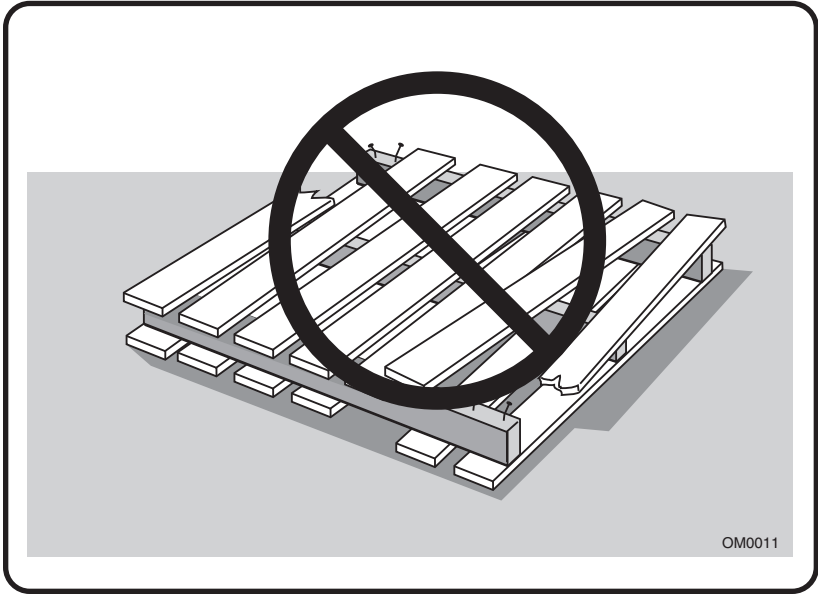

WARNING

Do not move or store materials on damaged pallets or skids. Items can fall through them causing severe injury or death!

Be sure the pallet or skid you are using is in good condition and does not have defective or missing components and fasteners.

Contents

Truck Description	3.2
Operator Compartment	3.3
Operator Controls	3.4
Key Start	3.4
Steering System	3.4
Parking Brake System	3.4
Diagnostic Display	3.5
Multi Function Control Handle	3.6
Lift Control	3.6
Tilt Control	3.7
Horn Button	3.7
Function Change Button	3.7
Variable Tilt Feature	3.8
Tilt Restriction Indicator	3.8
Vertical Mast (Forks Level)	3.9
Auxiliary Valve Control (optional)	3.9
Plugging	3.10
Parking Brake System	3.10
Truck Data Plate and Capacity Plate	3.11
Operator Safety Warning Decals	3.12

Truck Description ESX

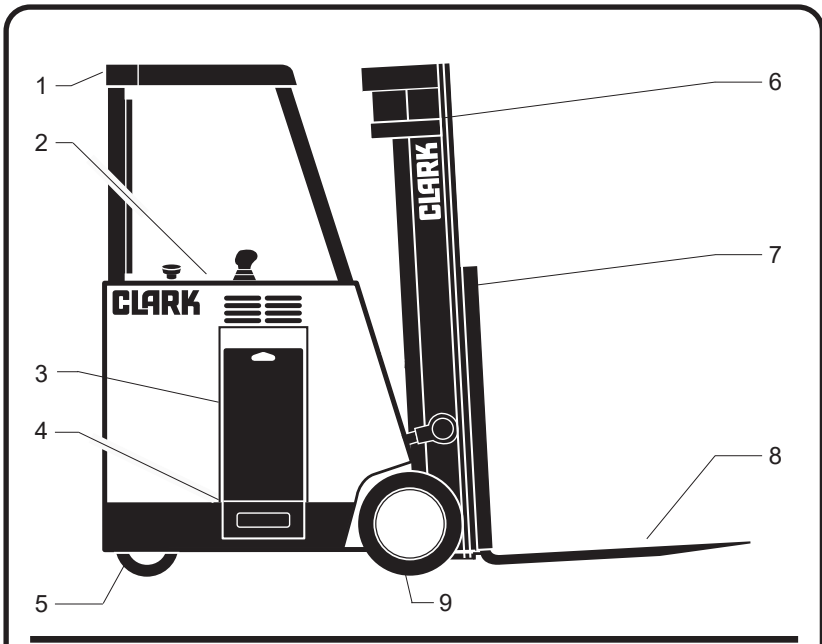

- | | |
|---|----------------------|
| 1 | Overhead Guard |
| 2 | Operator Compartment |
| 3 | Battery Compartment |
| 4 | Battery Retainer |
| 5 | Steer Wheels |
| 6 | Upright |
| 7 | Load Backrest |
| 8 | Forks |
| 9 | Drive wheels |

Operator Compartment

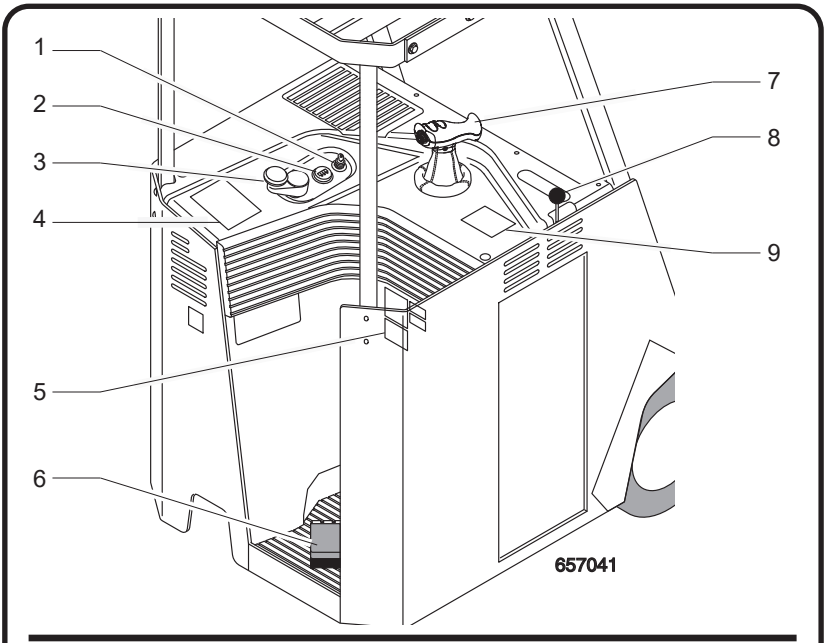

- | | |
|---|-------------------------------|
| 1 | Key Switch |
| 2 | Diagnostic Display |
| 3 | Steering Tiller |
| 4 | Warning Decal |
| 5 | Nameplate and Data Plates |
| 6 | Parking Brake |
| 7 | Multi Function Control Handle |
| 8 | Battery Disconnect |
| 9 | Control Handle Decal |

Operator Controls

Key/Start Switch

- Connects the battery with all truck operating systems (drive, lift, and steer electrical circuits) including the horn.
- Connects battery to the diagnostic display.

The key switch must always be turned to the **ON** position to operate the truck. When the key is in the vertical **OFF** position, instruments, drive and pump motor electrical circuits are disconnected (shut-off), and the key can be removed. The horn will not operate if the key switch is turned Off.

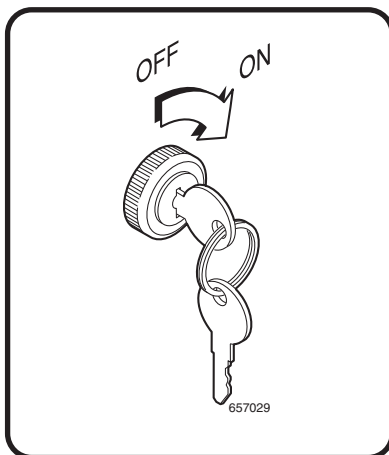

Steering System

The steering tiller has a "soft grip" knob to control the hydraulically-assisted power steering. The tiller is oriented for maximum ease of use in forward or reverse travel.

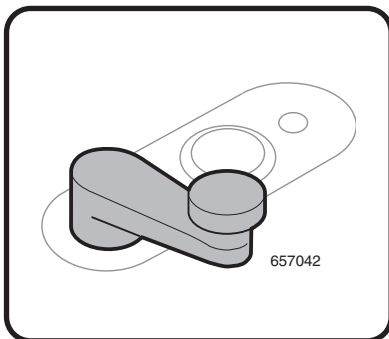

Parking Brake System (Emergency Brake)

Consists of spring-applied electro-magnetic release disc brakes. The parking brakes are activated by allowing the brake pedal to rise. This brake should never be used as the normal stopping device for the truck. The parking brake will automatically be applied after the truck has come to a complete stop and will not release until the multi function control lever is moved into the forward or reverse direction. The parking brake pedal must be depressed to allow the truck to move forward or reverse or to operate the hydraulic functions.

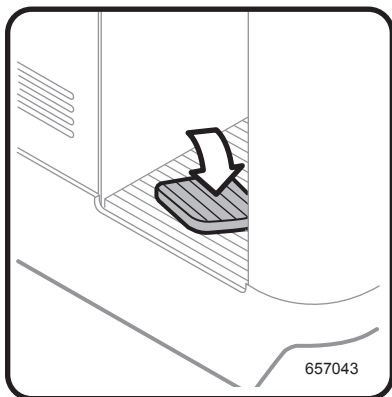

Diagnostic Display

The standard diagnostic display indicates the operating hours registered on the truck, a scale of usable charge left on the battery, fault codes, speed reduction indicator and a LED that indicates when the tilt is outside of the restricted tilt range. The hour meter or fault codes display when the key switch is **ON**. The hour meter reading is indicated along with the hour glass symbol and an alarm is indicated along with the wrench symbol. If the truck is operating in a speed reduction mode, the turtle indicator will be present.

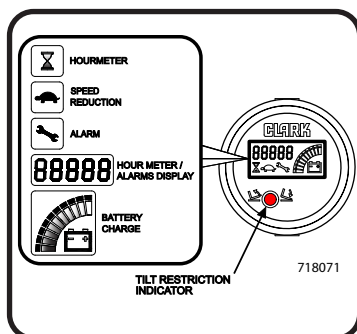

Using the Diagnostic Display

Your truck has a Diagnostic Display. "88888" should display on the digital readout for about one second after you turn the key switch to ON. This indicates that the digital readout is OK. After one second, either the hour glass symbol or the wrench symbol should come on.

If the hour glass symbol comes on, the digital readout shows the truck operating hours. If the wrench symbol comes on, an alarm code appears on the digital readout. The alarm code may indicate an easily correctable "operator fault" or it may indicate that you need to have the truck serviced.

The battery state of charge scale is divided into 10 segments indicating every 10% of battery charge. When the gauge registers 10% (one LED), the lift, tilt, and auxiliary functions become inoperable and the truck's travel speed is greatly reduced. At this point the battery will be 80% discharged. Charge or replace the battery immediately.

If you see an alarm code, use the table below as a guide. The codes listed below are usually the operator alarm codes (faults). Any other code is a service code.

Code	Condition	Likely Corrective Action
AL001	Parking brake switch open	Release parking brake.
AL079	Incorrect Start (SRO)	Put direction control in NEUTRAL before starting.
AL036	Incorrect Parking Brake Usage	Use Plugging Function to stop the truck.
AL066	Lift Lockout	Charge or Replace Battery
AL077	Maintenance Hours Reached	Call Service Technician for PM Service.

Code	Condition
AL205	Incorrect Start (SRO)
AL217	Wrong Battery Voltage
AL245	Wrong Battery Voltage
AL248	Parking Brake Self Test
Other	Truck needs service

Likely Corrective Action
Hydraulic function lever not in Neutral.

Check battery for Proper Voltage.

Check battery for Proper Voltage.

Call Service Technician.

Call Service Technician.

Multi-Function Handle (Direction Control)

To move the truck either forward or reverse, move the handle in the direction that you want the truck to move. Move the multi function handle toward the front of the truck (*to the drivers right*) to go forward. To move in the reverse direction, move the handle toward the rear of the truck (*to the drivers left*). The farther you move the multi function handle the faster the truck will travel.

NOTICE

The direction control handle must be in neutral position prior to turning the key to the ON position.

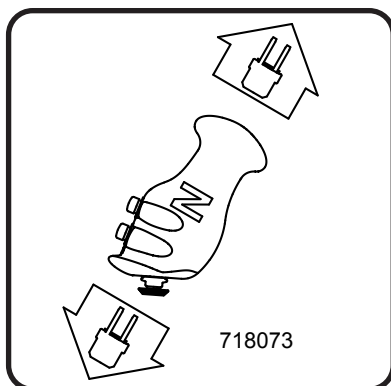

Lift / Lower Control

To lift or lower the upright you must also use the multi function control lever. Pull back the multi function handle to lift the forks. To lower the forks, push forward on the control handle. If the tilt restriction indicator is ON, it indicates that the upright is outside of the tilt restricted area. The upright will only raise to the top of the free-lift stage and then stop when tilted outside the allowable range. Tilt the upright to the vertical position to continue raising the forks.

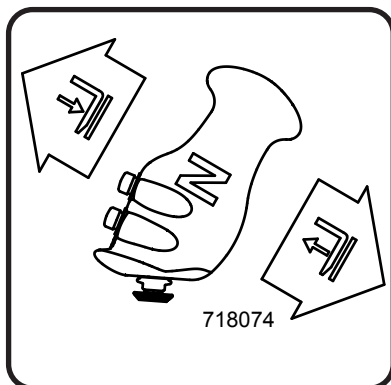

Tilt Control

The multi function control handle is equipped with a 4 way mini joystick that is operated with the thumb when the hand is on the multi function control handle. To tilt the forks forward move the mini joystick upward as noted in the illustration. To tilt the upright back move the mini joystick downward.

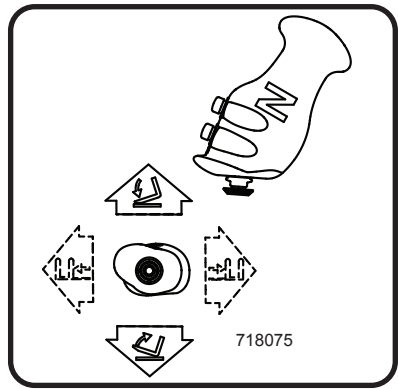

Horn Button

The horn button is located conveniently on the front face of the multi function control handle where your index finger typically rests. The horn should be sounded before entering all intersections to help reduce the likelihood of a collision with other lift trucks or pedestrians. This is for your safety and the safety of others. The key switch must be turned ON before the horn will operate.

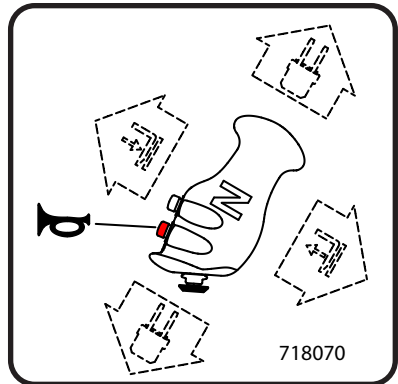

Function Change Button

The function change button is located to the right of the horn button where the middle finger typically rests. When this function change button is depressed and held, it controls the Fork Level function and the Auxiliary Valve 2 function (if equipped)

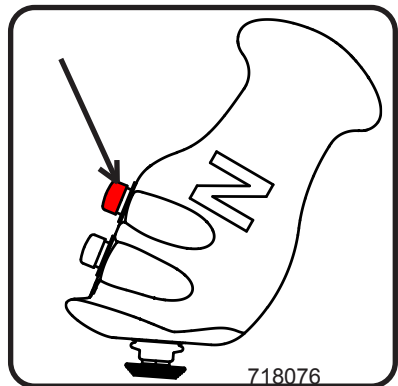

Variable Tilt Feature

The ESX truck is equipped with a tilt sensor and upright height limit switch that sends signals to the truck controls. These inputs are used to control the variable tilt features. The full and restricted tilt ranges will differ depending on the Maximum Fork Height (MFH) of the upright. The maximum restricted back tilt is stamped on the truck capacity plate.

FB=	Full Back Tilt Position
RB=	Restricted Back Tilt Position
V=	Vertical
RF=	Restricted Forward Tilt Position
FF=	Full Forward Tilt Position

- 1) Fast tilt speeds when forks are low
- 2) Full range of tilt when forks are low and restricted (limited) range of tilt when forks are high
- 3) Fork Level - See full description on following page.
- 4) Lift is disabled above free-lift if tilt is outside of Restricted Range.

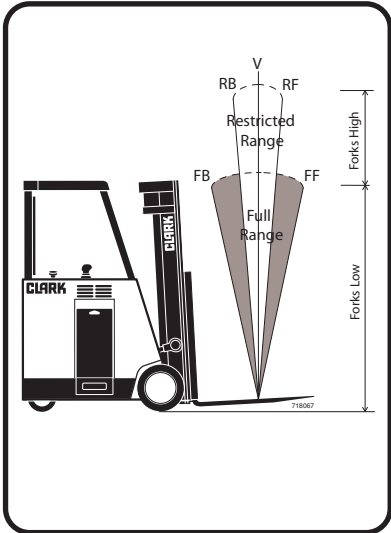

Tilt Restriction Indicator

A red indicator on the dash display will be illuminated any time the upright is outside of the tilt restriction area. Tilt the upright forward or backward, to the vertical position, to turn the indicator OFF and have the ability to raise the forks to the maximum height.

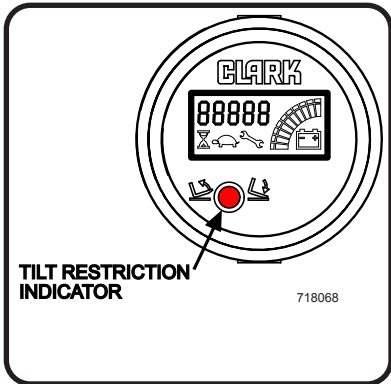

Fork Level

The Fork Level function operates by holding the function change button in, located on the multi function control lever, and using your thumb to operate the mini joystick up or down. While holding the function change button depressed, the tilt will stop when the upright is approximately vertical (forks level). This function will work while tilting forward and backward. The fork level position can be calibrated by a trained service technician and should be done anytime the upright is not returning to the vertical position.

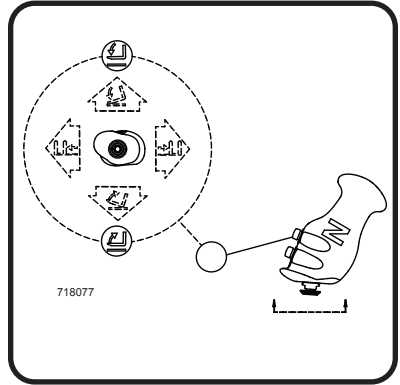

Auxiliary Valve 1 Control (Optional)

The operator's thumb on the 4 way mini joystick can activate this operation by moving the joystick forwards or backwards. (Example: If Aux 1 is used for sidershifter, moving the joystick forwards will sidershift the forks to the left. Moving the joystick backwards will sidershift the forks to the right.)

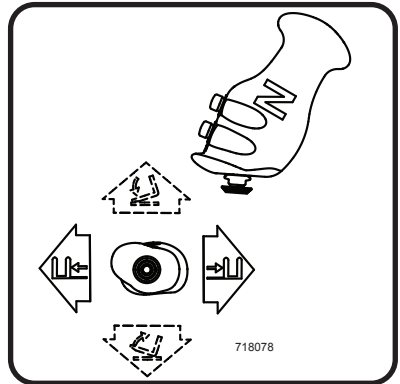

Auxiliary Valve 2 Control (Optional)

If your truck is equipped with an optional hydraulic attachment, the operator's thumb on the 4 way mini joystick can activate the second function by moving the mini joystick forwards or backwards while depressing the function change button.

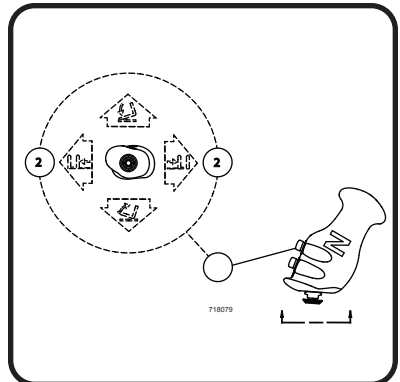

Plugging / Auto Plugging

Plugging is the preferred method of stopping the ESX trucks. Plugging allows you to change direction or stop without braking, by using the reverse torque of the drive motor to slow the truck to a stop. As you are traveling, move the multi function control handle towards neutral or into the opposite direction. The amount of movement of the handle in the opposite direction controls the distance required for the truck to slow to a smooth, controlled stop. The maximum handle movement will result in the shortest stopping distance.



CAUTION

Be careful when plugging. Any sudden change in direction can cause the load to move or fall off the forks.

Parking Brake System (Emergency Brake)

Consists of spring-applied electro-magnetic release disc brakes. The parking brakes are activated by allowing the brake pedal to rise. The drive motors will assist the Emergency Brake to stop the truck in an emergency as long as the key switch is turned ON and the battery is still connected. This brake should never be used as the normal stopping device for the truck. The parking brake will automatically be applied after the truck has come to a complete stop and will not release until the multi function control lever is moved into the forward or reverse direction. The parking brake pedal must be depressed to allow the truck to move forward or reverse or to operate the hydraulic functions.



CAUTION

Never operate your lift truck with the emergency / parking brakes not working correctly.

IMPORTANT

The Parking Brake should only be used for parking (after truck has come to a complete stop) or in case of an emergency. Excess use of the parking brakes to stop a moving truck will result in excessive wear of the brakes and possible failure.

Incorrect usage of the parking brake is stored in the traction controllers as an alarm -36. Alarm -248 will be displayed if the brakes fail the self test. This indicates the parking brakes may not function properly. Ensure truck is repaired before returning it to service.



Operator Safety Warning Decal

IMPORTANT

Safety and warning decals are placed in conspicuous locations on the truck to remind you of essential procedures or to prevent you from making an error that could damage the truck or possibly cause personal injury. You should know, understand, and follow these instructions. Safety and warning decals should be replaced immediately if missing or defaced (damaged or illegible). Refer to your Service Manual for location of all decals.



Leg Crushing Warning Decal

This decal is located to the left of the steer tiller and warns of the danger of not keeping your arms and legs within the operator compartment.

 WARNING	
	<p>Breaking these rules could cause death or serious injury to yourself and others.</p> <p>To avoid crushing injuries:</p> <ul style="list-style-type: none">• Keep feet, legs and all parts of body inside operator compartment during normal operation.• Look where you drive. Watch for pedestrians. Allow safe stopping distance. Come to a complete stop before leaving operator compartment. Avoid obstructions, especially to the rear and overhead. Avoid drop offs.• Do not operate this truck unless you are trained and authorized. Read, understand and follow instructions in the operator's manual attached to this truck before starting. Clark dealers have replacement manuals.• Perform daily inspection before operating truck. Never operate a truck in need of repair. <p><small>Stand Up Rider 2820926</small></p>



Upright Warning Decal

This safety decal is on the upright to warn of the danger of injury from movement between rails, chains, sheaves, fork carriage, and other parts of the upright assembly. Do not climb on or reach into the upright. Personal injury will result if any part of your body is put between moving parts of the upright.

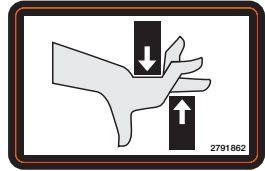

Keep Away from Forks Decal

This safety decal is placed on the upright to warn of the danger of injury from forks when they are in the raised position. Do not ride on or stand under forks or attachments. The forks can fall and cause injury or death. Always make sure that the forks are in the fully lowered position when they are not being used to handle a load.



Operator Maintenance and Care

Contents

Daily Safety Inspection	4.2
Visual Checks	4.3
Functional Checks	4.4
Concluding Inspection	4.5



CAUTION

The Occupational Safety and Health Administration (OSHA) requires that truck users examine their trucks before each shift to be sure they are in safe working order. Defects when found shall be immediately reported and corrected. The truck shall be tagged with a "Out Of Service" tag and taken out of service until it has been restored to safe operating condition.

Daily Safety Inspection

Before using a lift truck, **it is the operator's responsibility** to check its condition and be sure it is safe to operate.

Check for damage and maintenance problems; have repairs made before you operate the truck. Unusual noises or problems must be reported immediately to your supervisor or other designated authority.

Do not make repairs yourself unless you are trained in lift truck repair procedures and authorized by your employer. Have a qualified mechanic make repairs using genuine CLARK or CLARK-approved parts.



CAUTION

Do not operate a truck if it is in need of repair. If it is in an unsafe condition, remove the key and report the condition to the proper authority. If the truck becomes unsafe in any way while you are operating it, stop operating the truck, report the problem immediately, and have it corrected.

Lift trucks should be inspected every eight hours, or at the start of each shift. In general, the daily inspection should include the **visual** and **functional checks** described on the following pages.

As an aid in carrying out this inspection, CLARK has prepared a form called the "**Driver's Daily Checklist.**" We recommend that you use this form to make a daily record of your inspections and truck condition. You may obtain copies of this form from your CLARK dealer.



WARNING

Leaking hydraulic oil may be hot or under pressure. When inspecting a lift truck, wear safety glasses and do not check for leaks with bare hands.

Visual Checks

First, perform a visual inspection of the truck and its major components:

1. Walk around your lift truck and take note of obvious damage that may have been caused by operation during the last shift.
2. Check that all capacity, safety, and warning plates or decals are attached and legible.
3. Check that the battery is installed and secured in position correctly. Check battery connector for safe condition.
4. Check for hydraulic oil leaks and loose fittings



CAUTION

Do not use bare hands to check. Oil may be hot or under pressure.

5. Be sure that the driver's overhead guard, load back rest and all other safety devices are in place, securely fastened and undamaged. Inspect for damaged or missing parts, corrosion, cracks, breaks etc.
6. Check all of the critical components that handle or carry the load.
7. Look the upright and lift chains over. Check for obvious wear and maintenance problems such as damaged or missing parts, leaks, slack or broken chains, rust, corrosion, bent parts, cracks, etc.
8. Carefully inspect the load forks for cracks, breaks, bending, twists, and wear. Be sure that the forks are correctly installed and locked in their proper position.
9. Inspect the wheels and tires for safe mounting, wear condition.

Functional Checks

Check the operation of the truck as follows:

NOTICE

Before performing these checks, familiarize yourself with the operating procedures in Section 5.

1. Test warning devices, horn, lights, and other safety equipment and accessories.
2. With the key switch ON, check the diagnostic display. The diagnostic display should show the charge remaining on the battery, the hour meter or a fault code. If the fault code is not an operator fault code (described in "Section 5, Operating Procedures—Using the Diagnostic Display"), call a service technician.
3. Be sure all controls and systems operate freely and return to neutral properly. Check the:
 - Parking brake system.
 - Hydraulic controls: lift, tilt and side shift (if equipped)
 - Multi-function handle. (Direction/Accelerator control)
 - Steering system.

When the functional checks are completed:

1. Bring truck to complete stop.
2. Make sure the multi-function handle has returned to NEUTRAL.
3. Lower the lift mechanism fully and tilt the forks forward.
4. Apply the parking brake. (Brake will automatically apply when the pedal is released)
5. Turn the ignition switch to the OFF position.

If you are going to leave the truck unattended:

6. Remove the key.
7. Block the wheels, if the truck has the possibility of moving.
8. Unplug the battery.

Concluding the Inspection

Make a record on the "Driver's Daily Checklist" of all the operating and truck problems that you find. Review the checklist to be sure it has been completed and turn it in to the person responsible for lift truck maintenance. Be sure any unusual noises or problems are investigated immediately.

Do not operate a lift truck that has a maintenance problem, or is not safe to operate.

Remove the key from the ignition switch and put an "Out of Service" tag on the truck.

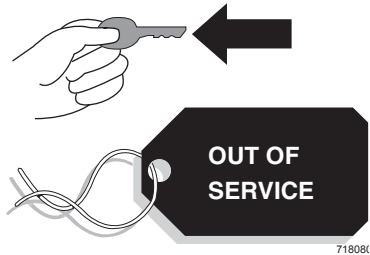

Be sure to put this Operator's Manual back in the holder in the operator's compartment. Read the manual again if you are not sure of all lift truck operating procedures.

If all of the Daily Inspection checks were normal or satisfactory, the truck can be operated.



Operating Procedures

Contents

Before Operating the Truck	5.2
Starting from a Safe Condition.....	5.3
Using the Diagnostic Display	5.4
Positioning Forks and Upright	5.5
Controlling Speed.....	5.6
Plugging	5.6
Parking Brake.....	5.6
Operating Safely	5.7
Adjusting the Load Forks	5.10
Load Handling.....	5.10
Traveling with a Load	5.11
Picking Up and Moving Loads	5.12
Unloading	5.13
Stacking	5.14
After Operating the Truck	5.16



Before Operating the Truck

Be sure that you have read and understand the information in this *Operator's Manual* before operating the lift truck.

The Operator's Manual is located conveniently in the operators compartment.

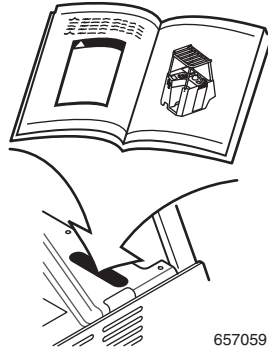

WARNING

- This equipment can be dangerous if not used properly. Safe operation is the responsibility of the operator.
- Do not start or operate the truck, or any of its functions or attachments, from any place other than the designated operator's position.

CAUTION

- Inspect your lift truck before operating at the start of the day or shift. Before putting your truck to use, check the operation of the controls and all systems.
- Protect yourself. Do not operate truck without a driver's overhead guard unless conditions prevent its use. Do not remove overhead guard unless specifically authorized. Use special care if operation without this safety device is required.

Starting from a Safe Condition

Always start from a safe condition. Before operating a lift truck, make sure that:

1. Parking brake is applied.
2. Forks are fully lowered to the floor or ground.



3. You are familiar with how all the controls function.
4. All controls are in neutral or other correct position.
5. Truck has received its daily inspection and is ready to operate.

When turning the key switch to ON, (with the multi-function handle released, the handle will be in the NEUTRAL position) the truck should start only in the NEUTRAL position.

Starting the Truck

Before you start the truck, make sure that you have taken all the above-mentioned precautions and that the directional control is in NEUTRAL. To start the truck, turn the key switch clockwise to the ON position.

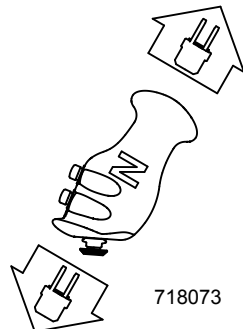

Using the Diagnostic Display

Your truck has a Diagnostic Display. "88888" should display on the digital readout for about one second after you turn the key switch to ON. This indicates that the digital readout is OK. After one second, either the hour glass symbol or the wrench symbol should come on.

If the hour glass symbol comes on, the digital readout shows the truck operating hours. If the wrench symbol comes on, an alarm code appears on the digital readout. The alarm code may indicate an easily correctable "operator fault" or it may indicate that you need to have the truck serviced.

The battery state of charge scale is divided into 10 segments indicating every 10% of battery charge. When the gauge registers 10% (one LED), the lift, tilt, and auxiliary functions become inoperable and the truck's travel speed is greatly reduced. At this point the battery will be 80% discharged. Charge or replace the battery immediately.

If you see an alarm code, use the table below as a guide. The codes listed below are usually the operator alarm codes (faults). Any other code is a service code.

Code	Condition	Likely Corrective Action
AL001	Parking brake switch open	Release parking brake by depressing brake pedal.
AL079	Incorrect Start (SRO)	Put direction control in NEUTRAL before starting.
AL036	Incorrect Parking Brake Usage	Use Plugging Function to stop the truck unless in an emergency.
AL066	Lift Lockout	Charge or Replace Battery
AL077	Maintenance Hours Reached	Call Service Technician for PM Service.
AL205	Incorrect Start (SRO)	Hydraulic function lever not in Neutral.
AL217	Wrong Battery Voltage	Check battery for Proper Voltage.
AL245	Wrong Battery Voltage	Check battery for Proper Voltage.
AL248	Parking Brake Self Test	Call Service Technician. Do not operate truck.
Other	Truck needs service	Call Service Technician. Do not operate truck.

Positioning Forks and Upright

When driving, with or without a load, it is good practice to always raise the forks slightly and tilt the forks backward. Raising the forks and tilting them back slightly prevents the fork tips from catching on possible obstructions and reduces the wear on the fork blades from striking or dragging on the floor or ground. See the NOTICE and CAUTION below.

Pull back on the multi-function control lever and raise the forks 6 to 8 inches (152 to 203 mm) above the floor.

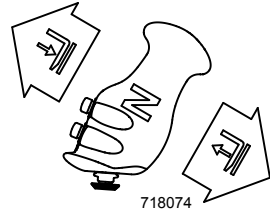

Then, using the tilt control, tilt the forks back slightly to raise the tips. The amount of forward and rearward tilt to be used is governed by the application.

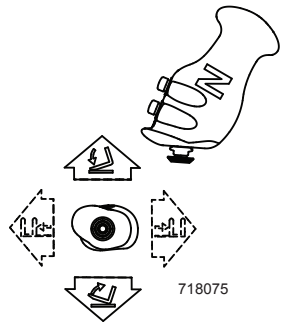

NOTICE

When the upright (carriage and/or load) is raised into a high (elevated) position, the stability of the truck is reduced. Some of the other conditions that may affect stability are: ground and floor conditions, grade, speed, loading, dynamic and static forces and the judgment exercised by the operator. Trucks equipped with attachments behave as partially loaded trucks even when operated without a load on the attachment. Also, improper operation, faulty maintenance or poor housekeeping may contribute to a condition of instability



CAUTION

For stability reasons, do not travel with the load or carriage in an elevated position. Travel with the lift mechanism raised only enough to clear the ground or obstacles.

Controlling Speed

To move the truck either forward or reverse, move the multi-function handle in the direction that you want the truck to move. Move the handle toward the front of the truck to go forward or toward the rear of the truck to move the truck in reverse. The further you move the handle right or left the faster your truck will move.



CAUTION

Stop a lift truck as gradually as practical. Hard braking and wheel sliding are dangerous and can increase wear and can be harmful to the lift truck. This pedal is not intended for normal braking use during operating the truck. It can be used for emergency stopping of the truck.

Plugging / Auto Plugging (Electric Braking)

Plugging is the preferred method of stopping the ESX trucks. Plugging allows you to change direction or stop without braking, by using the reverse torque of the drive motor to slow the truck to a stop. As you are traveling, move the multi function control handle towards neutral or into the opposite direction. The amount of movement of the handle in the opposite direction controls the distance required for the truck to slow to a smooth, controlled stop. The maximum handle movement will result in the shortest stopping distance.



CAUTION

Be careful when plugging. Any sudden change in direction can cause the load to move or fall off the forks.

Parking Brake (Emergency Brake)

The parking brakes are activated by allowing the brake pedal to rise. This brake should never be used as the normal stopping device for the truck. The parking brake will automatically be applied after the truck has come to a complete stop and will not release until the multi function control lever is moved into the forward or reverse direction. The parking brake pedal must be depressed to allow the truck to move forward or reverse or to operate the hydraulic functions.

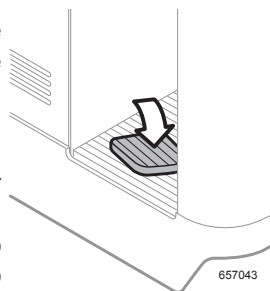

Operating Safely



WARNING

Safe operation is the responsibility of the operator. Watch where you are going. Don't go if you can't see.

Before driving, check all around to be sure that your intended path of travel is clear of obstructions and pedestrians.

While driving, be alert for pedestrians, other vehicles or obstructions in your path of travel.

Watch for pedestrians. Do not allow anyone to stand or pass under the load or raised forks. Watch for people in your work area even if your truck has warning lights or alarms. They may not watch for you.

Sound horn when approaching all intersections and wherever vision is obstructed. Do not drive a truck up to anyone standing in front of an object.

Protect yourself and those around you...

Operate the truck only from the designated operator's position. Stay within the confines of the lift truck profile dimensions. Keep arms, legs, feet and hands inside the operator's compartment and away from the danger of passing obstructions. Stay under the overhead guard.



718



CAUTION

An overhead guard is intended to offer protection to the operator from falling objects, but cannot protect against every possible impact. Therefore, it should not be considered a substitute for good judgment and care in loading, handling, storage, etc.

Keep clear of the upright and lift mechanism. NEVER reach into or put hands, arms, legs or head into or through the upright structure or near the carriage or lift chains. Never put any part of your body between the upright and the truck. Don't use the upright as a ladder.

Keep all other persons clear of the load and upright mechanism while attempting to handle a load.

No riders...

Do not carry passengers. The operator is the only one who should be on the truck.

Always be in full control of your lift truck...

Never operate a lift truck or its attachments if you are not in the designated operator's position.

Never operate a lift truck when your hands are wet or greasy.

Always pick the smoothest travel route for your lift truck. Avoid bumps, holes, slick spots, and loose objects or debris in your path that may cause the truck to swerve or tip. If these conditions are unavoidable, slow down and carefully drive past them. Slow down for wet or slippery surfaces.

Avoid any sudden movement. Start, stop, travel, steer, and brake smoothly.

Operate your lift truck under all conditions at a speed that will permit you to bring it to a safe stop.



WARNING

Travel slowly when turning. Use special care when traveling without a load because the risk of tipping over is greater with an empty truck, especially at high speed and when turning.

Travel with the fork carriage tilted back and raised only enough to fully clear the ground or obstacles. When the carriage (load) is in an elevated position the stability of the truck is reduced.

Do not elevate the load except during stacking.



CAUTION

Operate your lift truck only in areas that have been approved for your lift truck type designation. Certain areas contain flammable gases, liquids, dust, fibers, or other hazardous materials. Lift truck operations in these areas must have special approval. These areas must be designated to show the type of lift truck approval required for operation in the area. Be aware that changes to special equipment or poor maintenance can cause the lift truck to lose its special approval

**CAUTION**

Be sure that your truck is the correct fire safety type for the area in which you are working. The proper type designation for this truck is listed on the nameplate. In areas classified as hazardous, use only trucks approved for use in those areas. If you are unsure of the classification of the area you wish to enter, check before entering.

Practice safe operation every time you use your truck...

Careful driving and operation is your responsibility. Be completely familiar with all the safe driving and load handling techniques in this operator's manual. Use common sense. Drive carefully; do not indulge in stunt driving or horseplay. Observe traffic rules. Watch for people and hazards. Slow down. Be in full control of your lift truck at all times.

Follow the instructions in this manual to avoid damage to your truck or the possibility of injury to yourself or others.

During your work, observe all functions of your lift truck. This allows you to immediately recognize a problem or irregularity that could affect the safe operation of your truck.

Periodically check the diagnostics display in the instrument panel to be sure it indicates a normal condition. If an abnormal condition appears, shut off the key switch immediately and report the problem.

**WARNING**

Do not continue to operate a truck that has a malfunction. Tag the truck and remove it from service. Stop and have it fixed.

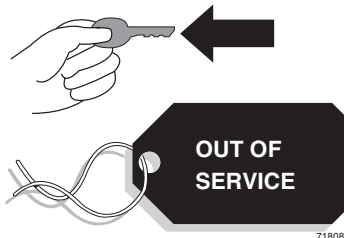

Adjusting the Load Forks

The load forks are adjustable on the carriage fork bar. Forks should be spaced as far apart as the load being carried will allow. Both forks should always be the same distance from the center of the fork carriage.

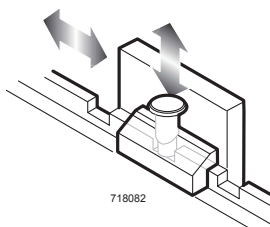

IMPORTANT

When adjusting forks ALWAYS push forks away from you, never pull forks toward you.

To adjust the forks, raise the carriage slightly. Tilt the upright fully forward to reduce friction and make the forks slide easier. Unlock the fork locking pins. Position the forks. Secure the fork locking pins.

Load Handling

Handle only loads that are within the truck rated capacity as shown on the nameplate. This rating specifies the maximum load that should be lifted. However, other factors such as special load handling attachments, loads having a high center of gravity, or uneven terrain may dictate that the safe working load be less than the rated capacity. Under these conditions, the operator must reduce the load being carried so that the lift truck remains stable.

Handle only stable or safely arranged loads. Do not handle loads made up of loose, unevenly stacked or unstable items that can easily shift and fall. Take the time to correctly stack and band loose items. Center the load on the forks.

Do not lift anything that might fall on the operator or a bystander.

Do not handle loads that are higher than the fork carriage or load backrest unless the load is secured so that no part of it can fall backwards.

Keep the load back against the carriage. Loads placed out on the ends of the forks can make the lift truck less stable and more likely to tip forward.

Lift and lower with the upright mast vertical or tilted slightly back — **never lift or lower with the upright mast tilted forward.**

Operate lift and tilt controls slowly and smoothly. Never tilt forward when carriage is raised, except to pick up or deposit a load over a rack or stack.





WARNING

Slack chains mean rail or carriage hang-up. Raise the upright before you move. If the upright malfunctions in any way or becomes stuck in a raised position, operate the lift control to eliminate any slack chains. Have the truck fixed by a trained and authorized mechanic. DO NOT go under a raised upright or forks to attempt repairs.

Remember, your lift truck is designed to carry loads forward of the front wheels so that the weight of the load is counter-balanced by the weight of the truck.

The farther the load is carried from the center of the front wheels, the lower the load on the rear wheel. Therefore, always carry the load as close to the front wheels as possible (back and flush against the face of the forks).

The capacity load shown on the nameplate is represented by a cube in which the weight is evenly distributed, with the center of gravity located a standard distance from the face of the forks. If the weight of the actual load to be handled is not evenly distributed, put the heaviest part closest to the carriage.

Traveling with a Load

Travel with load or carriage as low as possible and tilted back. Never travel with the load or carriage raised (elevated) in a high position, except during stacking.

Observe all traffic regulations and watch for other traffic, pedestrians, and safe clearances. Always look in the direction of travel. Keep a clear view of the path of travel, and when the load blocks your visibility, travel in reverse with load trailing (except when climbing an incline).

Avoid sudden movements when carrying a load—start, stop, travel, steer, and brake smoothly. Steer clear of bumps, holes, and loose materials or debris on the ground. Lift and tilt slowly and smoothly. Go slowly when turning.

Use special care when handling and traveling with long, high, or wide loads—to avoid losing the load, striking bystanders or obstructions, or tipping the truck.

Watch clearances around the truck and load as you travel. Raise the forks or attachment only to pick up or stack a load. Look out for obstructions, especially overhead.

Be aware that exaggerated tail swing, when turning while traveling forward, is a characteristic of lift trucks that are steered by the rear wheels. Accordingly, you need to become accustomed to tail swing and always check the tail swing area of the counterweight to be sure it is clear before you turn.

Always be concerned about the stability of your lift truck. When attachments are used, extra care should be taken in securing, manipulating, positioning, and transporting the load. Because attachments generally add extra weight and complexity to the truck, operate trucks equipped with attachments as partially-loaded trucks when not handling a load.

Picking Up and Moving Loads

When picking up a load from the ground, approach the load slowly and carefully align the truck square with the load. The forks should be adjusted to fit the load or pallet being handled and spread as wide as possible to provide good stability and balance. With the lift and tilt controls, adjust the forks to the correct height and angle for freely engaging the load pallet.

Move forward until the forks are squarely and completely under the load. Before lifting, be sure the load is centered and the forks are fully under and supporting the load. Fork length should be at least $\frac{2}{3}$ of load length.

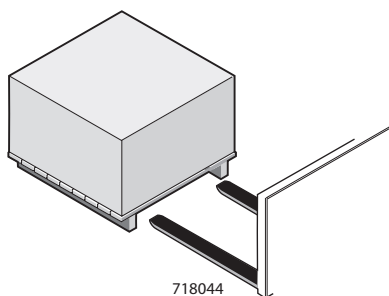

NOTICE

Be sure that the forks do not extend beyond the load, causing damage or tipping of other adjacent loads or materials behind the load being moved.

If the forks are longer than the load, move the tips partially under the load without extending beyond the load. Raise the load to clear the floor. Back out several inches, or whatever distance is necessary, then set the load down and move forward until the load is positioned against the face of the forks.

Raise the load from the floor or stack by tilting the upright back just enough to lift the load from the surface. When stacking or tiering, use only enough backward tilt to stabilize the load.

Then raise the load to traveling height and tilt fully back to travel (except for special loads that must be transported as level as possible).

Unloading

To deposit a load on the floor after being moved into the correct position, tilt the upright forward to a vertical position and lower the load.

Adjust the fork height and tilt the upright forward slightly, as necessary, for smooth removal of the forks from the load (pallet).

Carefully back away to clear the forks from the load.

Raise the forks to traveling height and tilt fully back.

Stacking

To put a load on a stack:

Approach slowly and align the lift truck and load squarely with the stack. Level the load as the lift truck is nearing the stack using the Fork Level function. Move forward, slowly, until the load is almost touching the stack. The leading edge and sides of the load pallet should be lined up exactly with the near edge and side of the load or rack on which you are stacking.

Fig 1 Stop close to the stack and level the forks using the Fork Level function.

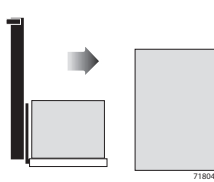

Fig 2 Lift (raise) the load high enough to clear the top surface of the stack.

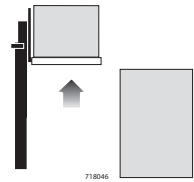

Fig 3 Slowly move the load into position. Be careful not to damage or move adjacent loads.

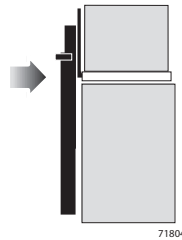

Fig 4 When the load is aligned with the stack beneath it, carefully lower the load onto the top surface of the stack.

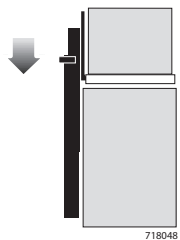

Fig 5 Lower (drop) the forks slightly to clear (disengage) the load pallet. Tilt the forks forward slightly, if necessary.

Fig 3

Fig 4

Fig 6 Check your travel path, then carefully back away until the forks are clear of the stack. Stop and lower the forks to the travel position (6 to 8 inches above the ground), then tilt back to travel.

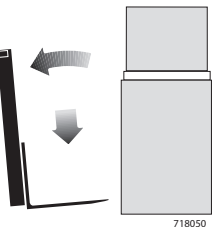
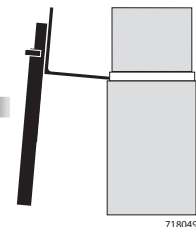

Fig 5

Fig 6



To move a load from a stack:

Approach the stack carefully, truck lined up squarely with the load. With upright vertical, raise the forks to the correct height for freely engaging the load pallet. Adjust fork angle as necessary to fit squarely under the load. Move forward until the forks are under the load.

NOTICE

Be sure that the forks do not extend beyond the load, causing damage or tipping of other adjacent loads or materials behind the load being moved. If the forks are longer than the load, move the tips partially under the load without extending beyond the load. Raise the load to clear the undersurface. Back out several inches, then set the load down and move forward until the front face of the forks contacts the load.

Raise the load from the stack by tilting the upright back just enough to lift the load from the surface. Or, with the upright still vertical, raise the forks until they begin to lift the load. At this point, apply the minimum back tilt that will stabilize the load.

Check your travel path, slowly back off until clear of the stack, stop, and then lower the load to the travel position (6 to 8 inches off the ground). Tilt full back to travel (except for certain loads that may have to be transported as level as possible). Be sure the load is back flush against the carriage or front face of the forks.

NOTICE

Certain loads may have to be transported as level as possible.

After Operating the Truck

Always leave your lift truck in a safe condition. When you leave your truck, or park it, follow these safety rules:

- Park in a safe area away from normal traffic.
- Never park on a grade.
- Never park in areas that block emergency routes or equipment, access to fire aisles, or stairways and fire equipment.

Before leaving the operator's position:

1. Bring truck to complete stop.
2. Put the multi-function handle in the NEUTRAL position.
3. Lower the lifting mechanism—carriage and forks or attachment—fully to the floor.
4. Apply the parking brake.

In addition, when leaving the truck unattended:

5. Tilt the upright forward until the forks are level and flat on the floor.
6. Turn the key switch to the OFF position.
7. Block the wheels if the truck must be left on an incline or you have any doubt about the truck moving from a safe position.

Planned Maintenance

Contents

Introduction	6.2
Safe Maintenance Practices	6.3
Planned Maintenance	6.6
Component Location	6.7
Daily Maintenance Checks.....	6.8
Periodic Maintenance Checks	6.9
PM Report Form.....	6.10
Visual Inspection	6.11
How to Perform PM.....	6.12
Functional Tests	6.15
SCR Traction Control	6.20
Checking the Hydraulic Fluid	6.21
Air Cleaning the Truck.....	6.22
Electric Truck Battery Maintenance	6.23
Battery Handling	6.24

Introduction

Regular maintenance and care of your lift truck is not only important for full and efficient truck life; it is essential for your safety. The importance of maintaining your lift truck in a safe operating condition by servicing it regularly and, when necessary, repairing it promptly cannot be emphasized too strongly. Experience has shown that powered industrial trucks can cause injury if improperly used or maintained. In the interest of promoting safety, several current industry and government safety standards specify that any powered industrial truck not in safe operating condition be removed from service and that all repairs be made by trained and authorized persons.

To assist you in keeping your lift truck in service and in good operating condition, this section outlines maintenance procedures that should be done at regular intervals. This planned approach is considered essential to the life and safe performance of your truck.

It is your responsibility to be alert for any indication that your truck may need service and have it attended to promptly. You play an important part in maintenance. Only you can make sure that your lift truck regularly receives the care it needs.



CAUTION

Powered industrial trucks may become hazardous if maintenance is neglected.

Safe Maintenance Practices

The following instructions have been prepared from current industry and government safety standards applicable to industrial truck operation and maintenance. These recommended procedures specify conditions, methods, and accepted practices that aid in the safe maintenance of industrial trucks. They are listed here for the reference and safety of all workers during maintenance operations. Carefully read and understand these instructions and the specific maintenance procedures before attempting to do any repair work. When in doubt of any maintenance procedure, please contact your local CLARK dealer.

1. Electric powered industrial trucks can become hazardous if maintenance is neglected. Therefore, suitable maintenance facilities and trained personnel and procedures shall be provided.
2. Maintenance and inspection of all industrial trucks shall be performed in conformance with the manufacturer's recommendations.
3. Follow a scheduled planned maintenance, lubrication, and inspection system.
4. Only trained and authorized personnel are permitted to maintain, repair, adjust, and inspect industrial trucks—and must do so in accordance with the manufacturer's specifications.
5. Always wear safety glasses. Wear a safety (hard) hat in industrial plants and in special work areas where protection is necessary and required.
6. Properly ventilate work area, keep shop clean and floors dry.
7. Avoid fire hazards and have fire protection equipment present in the work area. Do not use an open flame to check for leakage. Do not use open pans of fuel or flammable cleaning fluids for cleaning parts.
8. Before starting work on truck:
 - a. Raise drive wheels free of floor and use oak blocks or other positive truck positioning devices.
 - b. Remove all jewelry (watches, rings, bracelets, etc.).
 - c. Put oak blocks under the load-engaging means, upright rails, or chassis before working on them.
 - d. Disconnect the battery receptacle before working on the electrical system.



CAUTION

Refer to the "Jacking and Blocking" section in the Service Manual for proper procedures.

9. Operation of the truck to check performance must be conducted in an authorized, safe, clear area.
10. Before starting to operate the truck:
 - a. Be in a safe operating position.
 - b. Make sure parking brake is applied.
 - c. Put the direction control in NEUTRAL.
 - d. Check functioning of lift and tilt systems, direction and speed controls, steering, brakes, warning devices, and load handling attachments.
11. Before leaving the truck:
 - a. Stop the truck.
 - b. Fully lower the load-engaging means: upright, carriage, forks or attachments.
 - c. Put the directional control in NEUTRAL.
 - d. Apply the parking brake.
 - e. Turn the key switch to the OFF position.
 - f. Put blocks at the wheels if the truck must be left on an incline.
12. Brakes, steering mechanisms, control mechanisms, warning devices, lights, lift overload devices, lift and tilt mechanisms, load back rest, overhead guard and frame members must be carefully and regularly inspected and maintained in a safe operating condition.
13. Special trucks or devices designed and approved for hazardous-area operation must receive special attention to insure that maintenance preserves the original approved safe operating features.
14. All hydraulic systems must be regularly inspected and maintained in conformance with good practice. Tilt and lift cylinders, valves, and other parts must be checked to assure that "drift" or leakage has not developed to the extent that it would create a hazard.
15. When working on the hydraulic system, be sure the key switch is turned OFF, upright is in the fully-lowered position, and hydraulic pressure is relieved in hoses and tubing.

**WARNING**

Always put oak blocks under the carriage and upright rails when it is necessary to work with the upright in an elevated position.

16. The truck manufacturer's capacity, operation, and maintenance instruction plates, tags, or decals must be maintained in legible condition.
17. Batteries, limit switches, protective devices, electrical conductors, and connections must be maintained in conformance with good practice. Special attention must be paid to the condition of electrical insulation.
18. To avoid injury to personnel or damage to the equipment, consult the manufacturer's procedures in replacing contacts on any battery connection.
19. Industrial trucks must be kept in a clean condition to minimize fire hazards and help in detection of loose or defective parts.
20. Modifications and additions that affect capacity and safe truck operation must not be done without the manufacturer's prior written approval. Capacity, operation, and maintenance instruction plates, tags, or decals must be changed accordingly.

As outlined previously, you should always make a safety inspection of your lift truck before operating it. The purpose of this daily examination is to check for any obvious damage and maintenance problems, and to have minor adjustments and repairs made to correct any unsafe condition.

In addition to the daily inspection, CLARK recommends that you set up and follow a periodic planned maintenance (PM) and inspection program. Performed on a regular basis, the program provides thorough inspections and checks on the safe operating condition of your lift truck. The need for major adjustments, repairs, or replacements is found and corrections made as required, not after failure has occurred. The specific schedule (frequency) for these PM inspections depends on the conditions of your particular application and lift truck usage.

The recommended planned maintenance and lubrication schedule lists those items considered essential to the safety, life, and performance of your truck with typical recommended service intervals. Brief procedures for inspections, operational checks, cleaning, lubrication, and minor adjustments are included for your reference.

Your local CLARK dealer is prepared to help you with your Planned Maintenance Program, if you want assistance. Your CLARK dealer has specially trained service personnel who are authorized to check your lift truck according to the applicable safety regulations.

"Section 7, Specifications," contains some useful information for selected components, lubricants, critical bolt torques, refill capacities, and settings for your truck.

If you have the need for more information on the care and repair of your truck, see your CLARK dealer.



Major Component Location

Use the illustration below to help you locate components included in the PM procedures.

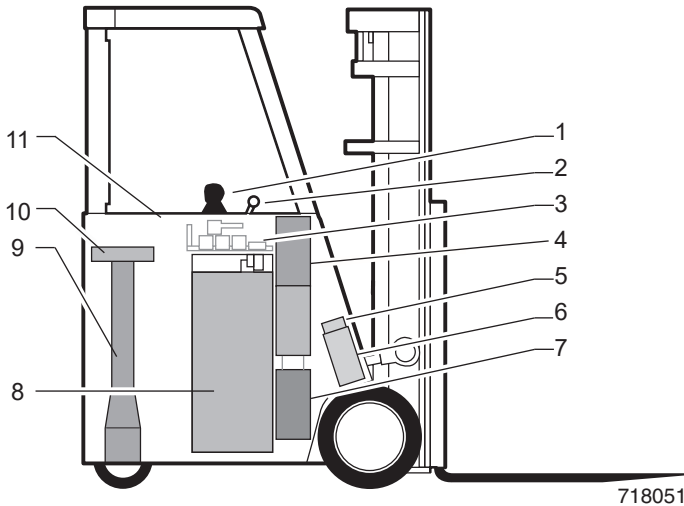

- | | |
|---------------------------|---------------------------|
| 1. Multi Function Handle | 7. Sump Tank |
| 2. Battery Disconnect | 8. Battery |
| 3. Traction Control Panel | 9. Steer Axle and Housing |
| 4. Lift Pump and Motor | 10. Steer Actuator |
| 5. Parking Brakes | 11. Steer Handle |
| 6. Drive Motors | |

The truck shown above is a typical representation of a CLARK electric counterbalanced stand up lift truck. Your model may vary slightly.

Recommended PM Intervals

The maintenance time intervals referred to in this manual relate to truck operating hours as recorded by the diagnostic system and based on experience which CLARK has found to be convenient and suitable under typical (normal or average) operating conditions, as follows:

A = 8-10 hours or daily

B = 50-250 hours or every month

C = 450-500 hours or every 3 months

D = 900-1000 hours or every 6 months

E = 2000 hours or every year

DAILY MAINTENANCE CHECKS	A	B	C	D	E
Check truck for obvious damage and leaks.	•				
Check / Clean battery terminals.	•				
Check electrolyte level.	•				
Check capacity, warning plates and decals.	•				
Check condition of tires and wheels, remove embedded objects.		•			
Check wheel lug nuts.		•			
Check diagnostic display.		•			
Check overhead guard condition and bolts.		•			
Check horn operation and other warning devices.		•			
Check steering operation.		•			
Check parking brake operation.		•			
Check directional and speed control operations.		•			
Check lift, tilt and auxiliary operation.		•			
Check upright, lift chains and fasteners.		•			
Check load backrest extensions and forks.		•			
Check all safety equipment (lights and beacons, etc.)		•			

718052

Typical Operating Conditions

Time intervals between maintenances are largely determined by operating conditions. For example, operation in sandy, dusty locations requires shorter maintenance intervals than operation in clean warehouses. The indicated intervals are intended for **normal** operation. The following operating conditions are defined:



Normal Operation: Basically, eight-hour material handling, mostly in buildings or in clean, open air on clean paved surfaces.

Severe Operation: Prolonged operating hours or constant usage.

Extreme Operation:

- In sandy or dusty locations, such as: cement plants, lumber mills, and coal dust or stone crushing sites
- High-temperature locations, such as: steel mills, foundries, etc.
- Sudden temperature changes, such as: constant trips from buildings into the open air, refrigeration plants, etc..

If your fork lift truck is used in severe or extreme operating conditions, you must shorten the maintenance intervals accordingly.

NOTICE

Since the operating environment of lift trucks varies widely, the above descriptions are highly generalized and should be applied as actual conditions dictate.

PERIODIC CHECKS and PLANNED MAINTENANCE (PM)	A	B	C	D	E
Check truck visually and inspect components.	•				
Test drive truck/check functional performance.	•				
Air clean truck. (including electrical panel heat sinks)	•				
Check torque on critical fasteners.	•				
Lubricate truck. (See component illustration)	•				
Clean / Check battery terminals, electrolyte level.	•				
Check battery cables / truck receptacle.	•				
Perform battery load test.	•				
Test for shorts and grounds.	•				
Clean drive axle air vent.	•				
Check drive axle fluid level.	•				
Drain and replace drive axle fluid.					•
Check brake condition and wear.	•				
Check drive axle mounting and fasteners.	•				
Lubricate steer shaft.	•				
Check / Lubricate steer axle wheel bearings.	•				
Replace hydraulic sump fluid and filter.					•
Clean / Replace hydraulic sump breather.	•				
Lubricate tilt cylinder rod ends.	•				
Lubricate upright and fittings	•				
Check lift chain adjustment and wear.	•				
Check / Lubricate lift chains.	•				
Lubricate upright rollers.	•				

718053

CLARK

ELECTRIC AC TRUCK PLANNED
MAINTENANCE REPORT

CUSTOMER

MODEL & SERIAL NO.

INSPECTOR

SPECIAL INSTRUCTIONS

Comments:

CODE	OK
Passential	Adjust (Not PM)
Urgent	Repair or Replace
	Reqs Shop Repair
Date	Hour Meter
Date Last PM	HRS. Last PM
CLST PO. NO.	

AUTHORIZED SIGNATURE	INSPECTOR	SPECIAL INSTRUCTIONS	16 MOTORS	17 TEST DRIVE MACHINE	18 BRAKE SYSTEM	19 ELECTRICAL TESTS	20 DRIVE AXLE	21 BATTERY AND CABLES	22 STEERING SYSTEM	23 HYDRAULIC SYSTEM	24 SHOCKS	25 SHIRT METAL & C/W	26 LOAD BACK REST	27 OVERHEAD GUARD	28 ATTACHMENTS
			a. Drive Motor Condition b. Pump Motor Condition c. Service Brake Operation d. Speed Control e. Speed Sensor f. Direction & Control g. Return to Neutral h. Hydraulic System Operation i. Parking Brake Operation j. Switch (Brake) Operation k. Pedal Push & Luggage l. Accelerator Link m. Pedestrian Warning Device (If Equipped)	a. Drive Train Noise b. Steering Operation c. Service Brake Operation d. Speed Control e. Speed Sensor f. Direction & Control g. Return to Neutral h. Hydraulic System Operation i. Parking Brake Operation j. Switch (Brake) Operation k. Pedal Push & Luggage l. Accelerator Link m. Pedestrian Warning Device (If Equipped)	a. Check for Leaks b. Brake Reservoir Fluid Level c. Clean Vent Cap d. Pedal Free Travel e. Free Play f. Master Cylinder Mounting g. Service Brake Wear / Adjustment h. Park Brake Wear / Adjustment i. Brake Line Cable, Adjustment j. Brake Linkage, Check & Lubricate	a. Ground Test b. Cable & Terminal Condition c. Wire Harness Condition d. Accelerator Link e. Steering Link f. Governor To Governor g. Service Brake Switch Operation h. Parking Brake Switch Operation i. Start Switch Operation j. S.R.Q. k. P.A.M.T. l. Speed Limit Switches m. Choke Solenoid n. Hydraulic Valve Switches o. LIFT/Drive Transducer	a. Check for Leaks b. Oil Level - Condition c. Oil Pressure Operation d. Tire Condition	a. Check for Leaks b. Fluid Level - Condition c. Clean / Replace Breather d. Replace Filter e. Check Reservoir Mount f. Hose Condition g. Lift Speed (In/Sec) h. No Load i. Full Load j. DMT (As In/Sec) k. Lift Cylinder l. Tire Cylinder	a. Check for Leaks b. Fluid Level - Condition c. Clean / Replace Breather d. Replace Filter e. Check Reservoir Mount f. Hose Condition g. Lift Speed (In/Sec) h. No Load i. Full Load j. DMT (As In/Sec) k. Lift Cylinder l. Tire Cylinder	a. Check for Leaks b. Oil Level - Condition c. Oil Pressure Operation d. Tire Condition	a. Check for Leaks b. Fluid Level - Condition c. Clean / Replace Breather d. Replace Filter e. Check Reservoir Mount f. Hose Condition g. Lift Speed (In/Sec) h. No Load i. Full Load j. DMT (As In/Sec) k. Lift Cylinder l. Tire Cylinder	a. Condition b. Security of Mounting	a. Condition b. Security of Mounting	a. Condition b. Security of Mounting	

*See Maintenance Interval in Service Manual

319 750 0777 February 2007

A planned maintenance (PM) program of regular, routine inspections and lubrication is important for long life and trouble-free operation of your lift truck. Make and keep records of your inspections. Use these records to help establish the correct PM intervals for your application and to indicate maintenance required to prevent major problems from occurring during operation.

As an aid in performing and documenting your PM inspections, CLARK prepared an ***Electric Truck Planned Maintenance Report Form*** (PM Report Form). Copies of this form may be obtained from your authorized CLARK dealer. We recommend that you use this form as a checklist and a record of your inspection and truck condition.

The maintenance procedures outlined in this section are intended to be used in conjunction with the PM Report Form. They are arranged in groupings of maintenance work that are done in a logical and efficient sequence.

You make check marks or entries on the PM Report Form when you perform the PM. Please notice on the form a special coding system for indicating the importance of needed repairs and/or adjustments appears on the form.

When you have finished the PM inspections, be sure to give a copy of the report to the designated authority responsible for lift truck maintenance.

Do not make repairs or adjustments unless authorized to do so.



CAUTION

For safety, it is good practice to:

- **Remove all jewelry (watch, rings, bracelets, etc.) before working on the truck.**
- **Disconnect the battery before working on truck.**
- **Always wear safety glasses. Wear a safety (hard) hat in industrial plants and in special work areas where protection is necessary and required.**

How to Perform Planned Maintenance

Visual Inspection

First perform a visual inspection of the lift truck and its components. Walk around the truck and take note of any obvious damage or maintenance problems.

Check to be sure all capacity, safety, and warning plates attached are legible.

NOTICE

NAMEPLATES AND DECALS: Do not operate a lift truck with damaged or lost decals and nameplates. Replace them immediately. They contain important information.

Inspect the truck for any sign of external leakage. Check for hydraulic oil leaks and loose fittings.



CAUTION

HYDRAULIC FLUID PRESSURE: Do not use your hands to check for hydraulic leakage. Fluid under pressure can penetrate your skin and cause serious injury.

Be sure that the driver's overhead guard, load backrest extension, and safety devices are in place, undamaged, and attached securely. Then check all of the critical components that handle or carry the load.

Overhead Guard

Check the overhead guard for damage. Be sure that it is properly positioned and all mounting fasteners are in place and tight.

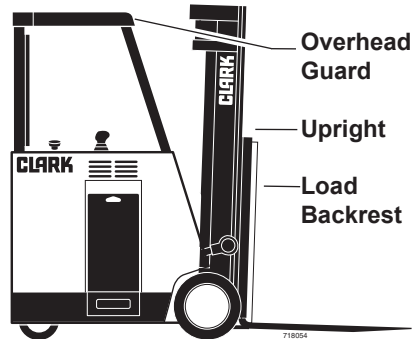

Load Backrest

Check the condition of the load backrest. Inspect the welds on the load backrest and carriage for cracks. Check that the load backrest mounting fasteners are not missing and properly tightened to specification. If the load backrest has been removed, make sure that fork stops have been installed on each side of the carriage.



IMPORTANT

If the lift truck is not equipped with a load backrest, or it has been removed, then fork stops must be installed on each side of the carriage to prevent the forks from being unintentionally forced off of the carriage during operation.

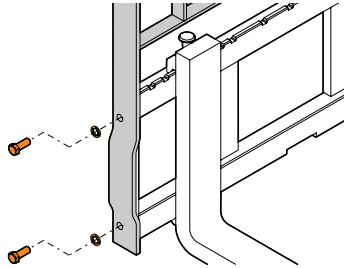

Upright Assembly

Inspect the upright assembly: rails, carriage rollers, lift chains, and lift and tilt cylinders. Look for obvious wear and maintenance problems, damaged or missing parts. Check for any loose parts or fittings. Check for leaks, any damaged or loose rollers, and rail wear (metal flaking). Inspect all lift line hydraulic connections for leaks

Lift Chain

Carefully check the lift chains for wear, rust, and corrosion, cracked or broken links, stretching, etc. Check that the lift and carriage chains are adjusted to have equal tension. Check that the lift chain anchor fasteners and locking means are in place and tight.



WARNING

Uprights and lift chains require special attention to maintain them in safe operating condition.

- **Uprights can drop suddenly. Look at the upright, but keep hands out.**
- **Lift chain repairs and adjustments should be made by trained service personnel.**

Forks

Inspect the load forks for cracks, breaks, bending and wear. The fork top surfaces should be level and even with each other. The height difference between both fork tips should be no more than 3% of the fork length.



WARNING

If the fork blade heel is worn down by more than 10 per cent, the load capacity is reduced and the fork must be replaced.

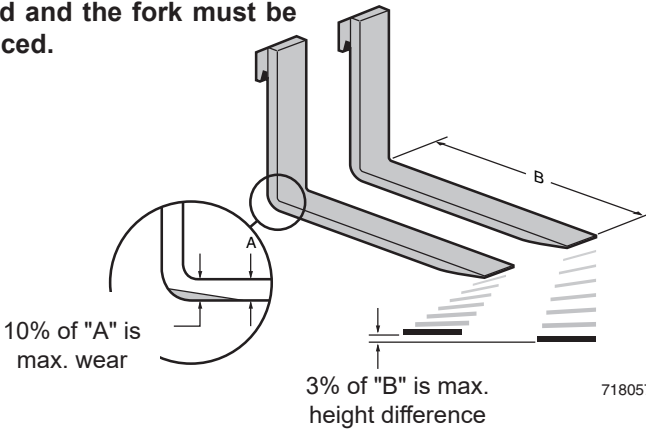
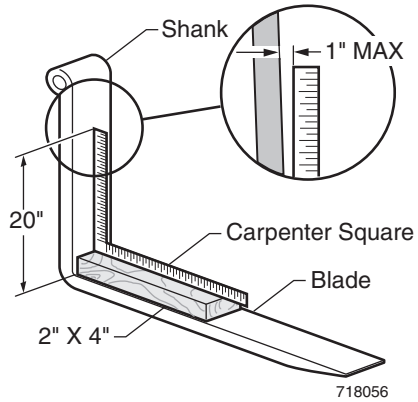

Inspect the forks for twists and bends. Put a 2"- thick wood block, at least 4" wide by 24" long, on the blade of the fork with the 4" surface against the blade. Put a 24" carpenter's square on the top of the block and against the shank. Check the fork 20" above the blade to make sure it is not bent more than 1" maximum.

If the fork blades are obviously bent or damaged, have them inspected by a trained maintenance person before operating the truck.

Inspect the fork latches. Be sure they are not damaged or broken and operate freely and lock correctly. Check the fork stop pins for secure condition.

Wheels and Tires

Check the condition of the drive and steer wheels and tires. Remove objects that are embedded in the tire. Inspect the tires for excessive wear and breaks or "chunking out" and bond failure between the tire and the rim.

Check all wheel lug bolts to be sure none are loose or missing.

Have missing bolts replaced and loose bolts tightened to the correct torque before operating truck.

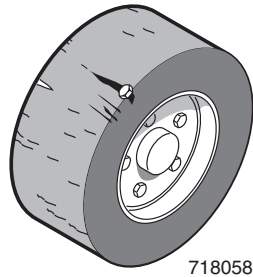

718058

Functional Tests

Now, check that all controls and systems are functioning correctly. Test horn, lights, and all other safety equipment and accessories. Be sure they are properly mounted and working correctly.

Press the horn button to check horn function. If the horn or any other part does not operate, report the failure, and have it repaired before the truck is put into operation (key switch must be ON to operate the horn).

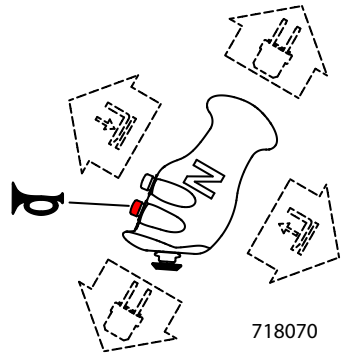

718070

Diagnostic Display

The standard diagnostic display indicates the operating hours registered on the truck, a scale of usable charge left on the battery, fault codes, speed reduction indicator and a LED that indicates when the tilt is outside of the restricted tilt range. The hour meter or fault codes display when the key switch is **ON**. The hour meter reading is indicated along with the hour glass symbol and an alarm is indicated along with the wrench symbol. If the truck is operating in a speed reduction mode, the turtle indicator will be present.

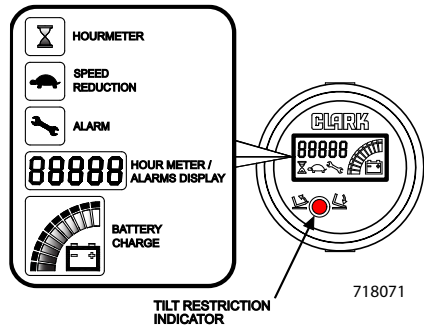

Your truck has a Diagnostic Display. "88888" should display on the digital readout for about one second after you turn the key switch to ON. This indicates that the digital readout is OK. After one second, either the hour glass symbol or the wrench symbol should come on.

If the hour glass symbol comes on, the digital readout shows the truck operating hours. If the wrench symbol comes on, an alarm code appears on the digital readout. The alarm code may indicate an easily correctable "operator fault" or it may indicate that you need to have the truck serviced.

The battery state of charge scale is divided into 10 segments indicating every 10% of battery charge. When the gauge registers 10% (one LED), the lift, tilt, and auxiliary functions become inoperable and the truck's travel speed is greatly reduced. At this point the battery will be 80% discharged. Charge or replace the battery immediately.

Parking Brakes

Operate parking brakes; multi function handle, all hydraulic controls - lift, tilt, and hydraulic options (if installed); directional controls; and steering system. Be sure all controls operate freely and return to neutral properly.

The trucks are equipped with electro-magnetic release, spring-applied brakes. This brake system needs periodic checks to ensure it is working properly.

To check brake holding capability and adjustment, park the lift truck at the bottom of a grade and release the parking brake pedal. The brake should hold a lift truck with rated load on a 15% grade. When the pedal is released, the truck should not move. If you find a brake problem, report it immediately. Do not operate the truck until the brakes are repaired.

The brake system ramp holding capability should be checked between 50 to 250 operating hours or every month.



CAUTION

Do not operate a lift truck if the parking brake is not operating properly.

Lift Mechanisms and Controls

Check the function of the lift system and controls.

Tilt the upright back by moving the mini joystick downward until the upright reaches the full back tilt position. Tilt the forks forward moving the mini joystick upward until the upright is in the vertical position. Release the lever.



CAUTION

Be sure that there is adequate overhead clearance before raising the upright.

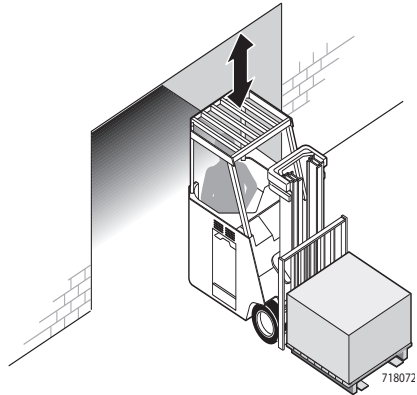

Pull back on the multi-function control handle and raise the fork carriage to full height. Watch the upright assembly as it rises. All movements of the upright, fork carriage, and lift chains must be even and smooth, without binding or jerking. Watch for chain wobble or looseness; the chains should have equal tension and move smoothly without noticeable wobble. Release the lever.

If the maximum fork height is not reached, this indicates there is an inadequate (low) oil level in the hydraulic sump tank or severe binding within the upright.

Push forward on the multi-function control handle. Watch the upright as it lowers. When the forks reach the floor, release the lever.

Auxiliary Controls

If your lift truck is equipped with an optional attachment, test for correct function and briefly operate the attachment. If there is a problem or you do not understand how the attachment works ask your supervisor for help.

Steering System

NOTICE

The steering system, steer axle, and steering linkage on your truck should be inspected periodically for abnormal looseness and damage, leaking seals, etc.. Also, be alert for any changes in steering action. Hard steering, excessive freeplay (looseness), or unusual sound when turning or maneuvering indicates a need for inspection or servicing.

Check the steering system by moving the steering tiller in a full right turn and then in a full left turn. Return the tiller (steer wheels) to the straight-ahead position. The steering system components should operate smoothly when the steering tiller is turned.

Never operate a truck with a steering system fault.

Direction Control

Check and make sure that the travel area is clear in front of the truck. Depress the parking brake pedal and move the control handle from NEUTRAL to FORWARD travel position. The truck should move in the forward direction. The travel speed is proportional to the amount of control handle movement. Return the control handle to NEUTRAL, truck should slow to a stop. Repeat this procedure in the reverse direction.

Regenerative Braking

Check and make sure that the travel area is clear. Travel at full speed and let the control handle return to neutral. The truck should quickly decelerate to a stop.

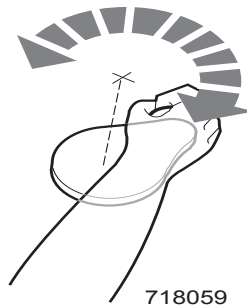

718059

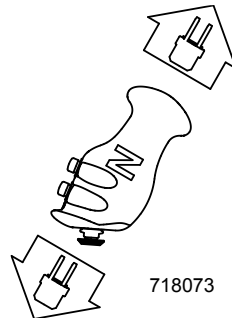

718073

TRACTION CONTROL



WARNING

Be sure to make a record of all maintenance and operating problems you find. Do not attempt to make repairs unless you are a trained authorized mechanic.

Test for correct function of the traction control. Check creep speed, maximum speed, and plugging.

1. Check creep speed and maximum speed while driving the truck in a straight line in both forward and reverse directions. All speed changes should be smooth while increasing and decreasing speed. Notice any unusual drive train noise or action of the controls and drive train components.

Stop the truck with the parking brakes. Note any unusual reactions in driving or braking performance. Note any need for adjustment.

2. Check the plugging function first at a slow speed. If operating correctly then test at full speed.

First drive the truck in the FORWARD direction. Move the multi-function handle to the forward position and allow the truck to accelerate to the desired travel speed. Then, move the multi-function handle to the REVERSE position. The truck should slow to a smooth, controlled stop and accelerate in the opposite direction.

Repeat the test by moving the direction control back to the forward position.

Check the multi-function control while conducting the speed range tests. It must move easily and smoothly throughout the acceleration stroke and return without binding.

Test the brake (drive motor cut-off) switches. From a stopped position, lift your heel off the brake pedal, this should shut off the power to the drive motors and prevent movement when the control handle is operated.

Check the steering potentiometer, to do so drive the truck slowly forward while turning the steer tiller. Each inside drive wheel (drive motor) must stop rotating (cut-off) when the steer wheel is turned at a sharp angle and should then reverse direction. The truck travel speed will reduce when the steer wheel is turned at a sharp angle.

When you have completed the operational tests, park and leave the truck according to standard shut down procedures.

Checking the Hydraulic Fluid

Check the hydraulic sump tank fluid level. Correct fluid level is important for proper system operation. Low fluid level can cause pump damage.

Hydraulic fluid expands as its temperature rises. Therefore, it is preferable to check the fluid level at operating temperature (after approximately 30 minutes of truck operation). The ESX truck requires a visual check of the fluid reservoir. To check the fluid level you must remove the front cover. You should have a trained and authorized mechanic check the fluid level for you. **Do not overfill.**

Check the condition of the hydraulic fluid (age, color or clarity, contamination). Change (replace) the oil as necessary.

Critical Fastener Checks

Fasteners in highly loaded (critical) components can quickly fail if they become loosened. Also, loose fasteners can cause damage or failure of the component. For safety, it is important that the correct torque be maintained on all critical fasteners of components that directly support, handle, or control the load and protect the operator.

Check critical items, including:

- Drive axle mounting
- Drive and steer wheel mounting
- Upright mounting & components
- Overhead guard
- Tilt cylinder mounting & rod ends
- Load backrest extension

Air Cleaning the Truck

Always maintain a lift truck in a clean condition. Do not allow dirt, dust, lint, or other contaminants to accumulate on the truck. Keep the truck free from leaking oil and grease. Wipe up all oil spills. Keep the controls and floorboards clean, dry, and safe. A clean truck makes it easier to see leakage and loose, missing, or damaged parts. A clean condition helps prevent fires and helps the truck run cooler.

The environment in which a lift truck operates determines how often and to what extent cleaning is necessary. For example, trucks operating in manufacturing plants with a high level of dirt, dust, or lint, (e.g., cotton fibers, paper dust, etc.) in the air or on the floor require more frequent cleaning. If air pressure does not remove heavy deposits of grease, oil, etc., it may be necessary to use liquid spray cleaner



Do not steam clean the Control Panel, motors or electrical components

Lift trucks should be air cleaned at every PM interval, and more often if needed.

Use an air hose with special adapter or extension having a control valve and nozzle to direct the air properly. Use clean, dry, low-pressure compressed air. Restrict air pressure to 30 psi (207 kPa), maximum (OSHA requirement).

IMPORTANT

Wear suitable eye protection and protective clothing.

Air clean: upright assembly; drive axle; battery; cables; switches and wiring harness; electrical control panels, heatsinks and wiring; drive and lift motors; and steer axle, steer cylinder, and linkage.

The control panels are mounted on finned heat sinks and small fans blow air through them to cool the panels. It is important to make sure these fins are kept free of dust, dirt and lint.

Electric Truck Battery Maintenance

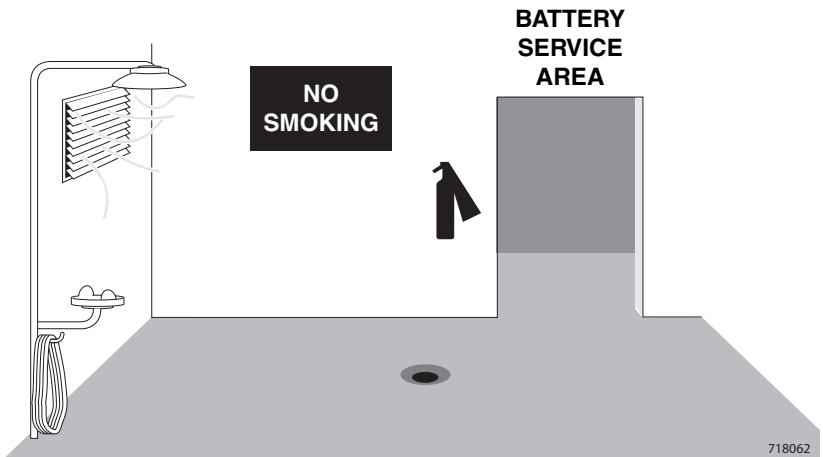

Battery charging installations must be located in areas designated for that purpose. These areas must be kept free of all non-essential combustible materials.

Facilities must be provided for:

- Flushing spilled electrolyte
- Fire protection
- Protecting charging apparatus from damage by trucks
- Adequate ventilation for dispersal of fumes from gassing batteries.

When handling acid concentrates greater than 50 percent acid (above 1.400 specific gravity), an eye wash fountain and deluge shower must be provided.

A conveyor, overhead hoist, or equivalent material handling equipment must be provided for handling batteries.

IMPORTANT

Electric truck batteries are heavy and awkward to handle. They are filled with a very hazardous chemical solution. On charge, they give off hydrogen and oxygen which, in certain concentrations, are explosive. And they are costly. Before you remove, service, or install a truck battery, carefully read the following recommendations and instructions.

Battery Handling

1. Change (remove) or service storage batteries only in an area designated for this purpose.
2. Be sure this area has provisions to flush and neutralize spillage, to ventilate fumes from gassing batteries, and for fire protection.
3. This area should be equipped with material-handling tools designed for removing and replacing batteries, including a conveyor or overhead hoist. Use lift hooks that have safety latches.
4. Always use a special lifting device such as an insulated spreader bar to attach the hoist to the battery. The width of the spreader bar hooks must be the same as the lifting eyes of the battery, to prevent damage to the battery. If the spreader bar hooks are movable, carefully adjust the position (width) of the hooks so that the pull is directly upward (vertical) and no side load or force (pressure) is exerted on the battery case. Be sure the lift hooks are the correct size to fit the lifting eyes of the battery.
5. If the battery does not have a cover of its own or has exposed terminals and connectors, cover the top with a non-conductive material, e.g., (a sheet of plywood or heavy cardboard), prior to attaching the lifting device.

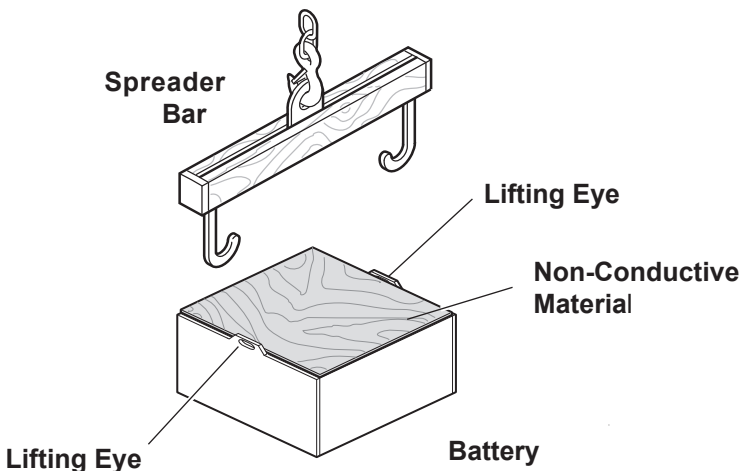

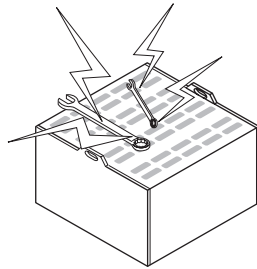
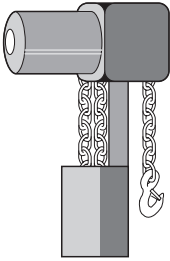

6. Chain hoists or power battery hoists must be equipped with load-chain containers to accumulate the excess lifting chain.
7. Keep all tools and other metallic objects away from the terminals.

**WARNING**

BATTERY SERVICE: Battery service must be done by trained and authorized personnel. Battery acid can cause severe burns and injury.

Battery Charging

1. Persons maintaining storage batteries must wear protective clothing such as face shield, long sleeves, rubber apron, and gloves.
2. Hydrogen emissions from charging batteries are flammable. No smoking is allowed in the charging area. Do not check the electrolyte level with an open flame. Do not allow open flame, sparks, or electric arcs in battery charging area.

**WARNING**

SULFURIC ACID: The battery contains corrosive acid that can cause injury. If acid contacts your eyes or skin, flush immediately with water and get medical assistance.



WARNING

EXPLOSIVE GASES: Do not smoke or have open flames or sparks in battery charging areas or near batteries. An explosion can cause injury or death.

3. When charging batteries, the vent caps must be kept in place to avoid electrolyte spray. Care must be taken to assure that vent caps are open (clean) and functioning. The battery or compartment covers must be open to dissipate heat and gas.

IMPORTANT

If batteries discharge rapidly during normal operation or do not charge to the correct specifications, contact a qualified battery service technician to check the battery for you. Do not add electrolyte or attempt to service the battery.

Battery Removal from Truck

1. Check the designated service and charging area for fire protection, and be sure all sources of ignition are cleared from the area. **Do not smoke.** Be sure all previous noted equipment is in the area, in good repair, and working properly. If the battery is to be serviced, be sure there are provisions to flush and neutralize spillage and to disperse (ventilate) fumes from gassing batteries on charge. And, be sure there are provisions for handling electrolyte.
2. Before attempting to remove or charge a storage battery, the truck should be positioned in the designated battery service area and the parking brake applied so the truck cannot move.
3. If the battery to be handled is not equipped with its own cover, cover the battery when handling with a non-conductive material, e.g., (plywood or heavy cardboard), before attaching the lifting device.
4. Use an approved device to remove the battery. Use an insulated spreader bar to lift or transport a truck battery. Be sure the hoist and lifting chains are equipped with safety hooks.
5. Remove the battery and move it to a safe storage location. Store batteries either on an approved battery rack or on a wooden pallet.

Battery Cleaning and Care

Never wash the battery when it is in the truck. The easiest and most satisfactory method of cleaning a battery is to wash it occasionally with a low-pressure cold-water spray.

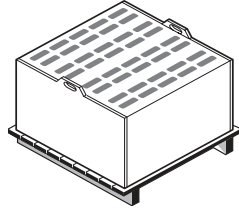

The top can also be washed off with a solution of baking soda and water (add a box of baking soda to a pail of water and stir until dissolved) and rinsed with clean water. It is good practice to have this solution in a battery room at all times.

IMPORTANT

During cleaning, the battery vent caps must be tightly in place.

Refer to the battery manufacturer or supplier for their recommended battery maintenance and care procedures.

BATTERY SAVER and CLEANER, CLARK Part No. 886398, may be used to clean and protect the truck battery.

New Truck Batteries: Apply a light coat of BATTERY SAVER and CLEANER to entire surface of battery. Allow to set for approximately 30 seconds, then wipe thoroughly with a wiping cloth or rag. Chemical action will dissolve rust and corrosion. After cleaning, apply a second coating for protection. This will prevent the start and growth of corrosion on battery terminals and cable connections.

Battery Service Records

Keep a record of battery service and maintenance to obtain the best service life from your battery and truck. Select a pilot cell, take readings of specific gravity and temperature before and after charging, and record the readings with the date. It is best to change the location of the pilot cell occasionally to distribute any electrolyte loss over the battery. Every 2 or 3 months, take complete battery readings (specific gravity, temperature, and voltage) and make a record of them.

How to Get Maximum Battery Life

1. Follow normal battery maintenance procedures, re-charging before 80% discharged and with periodic equalizing charges.

-
2. Don't add acid to a battery. Only a person trained and qualified to do battery maintenance should determine if this is necessary.
 3. Lift battery only with a correctly-constructed lifting device that will not put pressure on the battery case.
 4. Keep open flames, tools, and metal objects away from the top of battery to prevent short circuits and explosions.
 5. Do not overcharge.
 6. Check the battery electrolyte level **after** each charging. Add water if the top of the separator or plates are visible. **Do not overfill!**
 7. **Keep the battery clean and dry.** Wash down as needed.
 8. Keep battery service records.

Battery Installation

1. Use only a lead-acid battery with the voltage and ampere-hour rating specified for the truck.
2. When changing batteries on battery electric trucks, replacement batteries must be of the service weight that falls within the minimum/maximum range specified on truck nameplate.
3. Be sure truck is properly positioned and parking brake applied.
4. Handle battery only with approved lifting device. Ensure that the opposite battery side gate (battery stop) is in place before sliding battery into the compartment.
5. Install the battery correctly in the truck.
6. Install 2nd battery side gate (battery stop) and check that the battery is secured.

NOTICE

Some trucks are equipped with battery stops or blocks. Others do not require them. If the truck being serviced has battery stops or blocks, be sure none are missing or damaged. Replace them as necessary. If they are an adjustable type, be sure they are correctly adjusted and tightened.

Specifications

Contents

ESX 12-25	7.2
-----------------	-----



ESX 12 - 25

Clark products and specification are subject to improvements and changes without notice or obligation.

Model Designation — Rated Load Capacity

ESX12	2,500 lbs	@	24 in	[1250 kg	@	500 mm]
ESX15S	3,000 lbs	@	24 in	[1500 kg	@	500 mm]
ESX15	3,000 lbs	@	24 in	[1500 kg	@	500 mm]
ESX17	3,500 lbs	@	24 in	[1750 kg	@	500 mm]
ESX20	4,000 lbs	@	24 in	[1815 kg	@	500 mm]
ESX22	4,500 lbs	@	24 in	[2250 kg	@	500 mm]
ESX25	5,000 lbs	@	24 in	[2270 kg	@	500 mm]

Note: Specifications are given with triple stage upright, standard battery compartment size and minimum battery weight.

Truck Weights (approximate, with standard upright, Min. battery wt.)

	Service Wt.	Drive Axle Loading		Steer Axle Loading	
	w/o load	w/o load	w/load	w/o load	w/load
ESX12	8425[3822kg]	4266[1935kg]	8911[4042kg]	4159[1886kg]	2014[914kg]
ESX15S	8735[3962kg]	4404[1998kg]	9975[4525kg]	4331[1965kg]	1757[797kg]
ESX15	9055[4107kg]	4527[2053kg]	9987[4530kg]	4528[2054kg]	2068[938kg]
ESX17	9417[4271kg]	4659[2113kg]	10878[4934kg]	4758[2158kg]	2040[925kg]
ESX20	9752[4423kg]	4779[2168kg]	11731[5321kg]	4973[2256kg]	2021[917kg]
ESX22	10071[4568kg]	4814[2184kg]	12507[5673kg]	5257[2385kg]	2064[936kg]
ESX25	10686[4847kg]	5106[2316kg]	13673[6202kg]	5580[2531kg]	2013[913kg]

Tires

Note: Wide drive recommended for attachments capable of offsetting loads more than 4" (100mm) in each direction, left or right.

ESX 12/15S/15 - 18x7x12.1

Smooth cushion rubber - Drive

Lug type cushion - Drive

Non-marking rubber - Drive

Polyurethane - 18x6x12.1 - Drive

Solid pneumatic - 18x7 - Drive

Note: Solid pneumatic tires may reduce capacity

ESX 17/20 - 18x8x12.1

Smooth cushion rubber - Drive

Lug type cushion - Drive

Non-marking rubber - Drive

Polyurethane - 18x6x12.1 - Drive

Solid pneumatic - 18x9 - Drive

Note: Solid pneumatic tires may reduce capacity



ESX 22/25 - 18x9x12.1
 Smooth cushion rubber - Drive
 Lug type cushion - Drive
 Non-marking rubber - Drive
 Polyurethane - 18x7x12.1 - Drive

ESX 12/25 - Wide Drive - 18x9x12.1
 Smooth cushion rubber - Wide Drive
 Lug type cushion - Wide Drive
 Non-marking rubber - Wide Drive
 Siped Polyurethane - 18x9x12.1 - Wide Drive

Steer Tires (All Models)

Urethane

9x5x5 (2 per truck)

Battery Capacity Range

36 volt, 18 cells, 20.9-43.0 kWh, 600-1240 amp hr @ 6 hr rating Battery, fully charged: 1.275 specific gravity (1.310 Exide Load Hog)
 Discharged: 1.160 to 1.120 specific gravity

Battery Capacity Range

48 volt, 24 cells, 20.9-43.0 kWh, 600-1240 amp hr @ 6 hr rating Battery, fully charged: 1.275 specific gravity (1.310 Exide Load Hog)
 Discharged: 1.160 to 1.120 specific gravity

Fill Capacities—Fluid Volumes

Drive Axle: 6.8 quarts (6.44L)

Hydraulic Sump Tank (Usable Volume): 3.35 gal (12.68L)

Hydraulic Fluid Recommendation

Normal application - CLARK Specification MS-68 Hydraulic oil

Cold Storage or low temp. - CLARK Specification MS-226 Hydraulic oil

Drive Axle Fluid Recommendation: 80w-90 (Cold / Freezer 75w-90)

Axle Ends and wheel bearings:

NLGI Grade No. 1 Lithium soap base grease
 CLARK Specification MS-9B and MS-107B.

Steering linkage, upright mast & carriage rollers, trunnion bushings, tilt cylinder rod ends, brake pedal shaft:

NLGI Grade No. 2 Lithium soap base grease,
 CLARK Specification MS-107C.

Use genuine CLARK parts. See your CLARK dealer.

Scan Link Below



Safety Starts with You!



OM-718

CLARK[®] **Material Handling
Company**

**700 Enterprise Drive
Lexington KY 40510**

Additional copies of this manual are available from your CLARK dealer.