

OP15X

Operator's Manual

Do not remove this manual from the truck

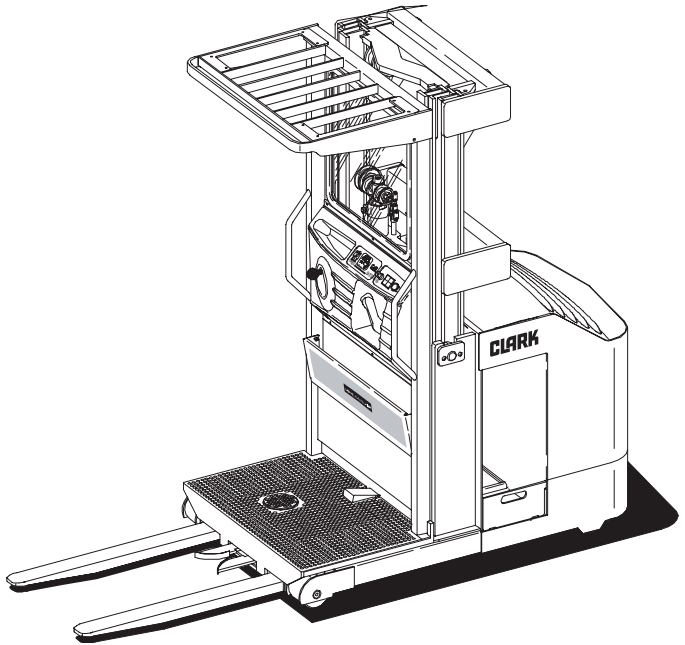

RATED CAPACITY: 3,000 lbs (1360 KG)

Book No. 934166

OM-714

CLARK Material Handling
Company

2317 Alumni Park Plaza
Suite 500, Lexington, KY
40517-4288

Record the serial number of your truck

Serial No. OP15X-

Customer Truck Identification No. _____

IMPORTANT

Do not expose this manual to hot water or steam.

CLARK is a trademark of **Clark Material Handling Company.**

© 2004 Clark Material Handling Co., Lexington, KY 40517-4288

All Rights Reserved.

Operator's warning



IMPORTANT NOTICE

This is the “**SAFETY ALERT SYMBOL**”. This symbol is used to call your attention to items or operations that could be dangerous to you or other persons using this equipment. Please read these messages carefully. It is essential that you read the instructions and safety regulations before you attempt to assemble or use this truck.

Before operating truck:

1. The operator must be instructed on safe and correct use of this truck.
2. The operator must read and understand the **Operator's Manual** for this truck.



WARNING

**BEFORE OPERATING TRUCK
STUDY OPERATOR'S MANUAL SAFETY MESSAGES.
READ ALL SAFETY DECALS ON TRUCK.
CLEAR THE AREA OF OTHER PERSONS.**

**LEARN AND PRACTICE USE OF
CONTROLS BEFORE OPERATING.**

IT IS YOUR RESPONSIBILITY TO UNDERSTAND AND FOLLOW MANUFACTURER'S INSTRUCTIONS ON TRUCK OPERATION AND TO OBSERVE PERTINENT LAWS AND REGULATIONS. OPERATOR MANUALS, PARTS MANUALS, AND SERVICE MANUALS MAY BE OBTAINED FROM YOUR EQUIPMENT DEALER.



Warning INJURY OR DEATH TO YOU OR OTHER PERSONNEL COULD OCCUR IF YOU DO NOT FOLLOW THESE INSTRUCTIONS AND MESSAGES.

Foreword

It is important that you read and understand this Operator's Manual for your own safety and the safety of those who work with you!

Before you start to use this truck it is of extreme importance that you have **read** the contents of the entire Operator's Manual to be able to use the truck in a **safe** and **efficient** manner.

This Operator's Manual contains information on how you should use the truck and how to keep the truck in a safe condition by following daily service routines.

Only personnel that have been trained as a truck operator, for this type of truck, are permitted to use this truck.

It is your employer's responsibility to ensure that you have been trained to use your truck safely. Contact your supervisor if you feel uncertain about how to use this truck.

Always follow the warnings given in this Operator's Manual and on the truck to avoid accidents.

Foreword

Standard Compliance

This truck complies with the following standards and regulation in effect on the date the truck was manufactured:

- American Society of Mechanical Engineers (ASME) B56.1
- Underwriters Laboratory (UL) # 583
- Occupational Safety and Health Administration (OSHA) 29 C.F.R. Section 1910.178

Dimensions and capacities

The dimensions and capacities shown in this manual have been converted from their original measurements and rounded for convenience. Metric dimensions and capacities are shown in brackets.

Table of Contents

Foreword	2
Standard Compliance	3
Dimensions and capacities	3
Safety regulations symbols	7
Warning symbols	7
Warning levels.....	7
Prohibitory symbols	8
Ordinance symbols	8
General safety regulations.....	9
Control.....	9
Operating the truck.....	10
Operator's responsibility.....	11
Working area.....	12
Driving and conduct while driving.....	13
Handling loads	15
Parking the truck	16
Handling the battery	17
Maintenance and repair	18
Warning and information decals	19
Warning decals	20
Presentation of Truck	21
Application area for Clark trucks.....	21
Prohibited applications for Clark trucks.....	21
Truck data	22
Truck battery dimensions	23
OP15X Truck dimensions	24
Data plate.....	25
Presentation of Main Components	26
Controls and Instruments	29
Emergency stop	29
Battery disconnect.....	30
Key switch	30
Horn control.....	30
Directional/Speed control handle	30
Steering wheel	31
Hydraulic controls.....	31
Switches - Lamps and fans	32
Display	33
Hourmeter	34
Brake pedal	35

Table of Contents

Pallet clamp foot pedal controls	37
To operate pallet clamp controls	37
Warning Caution Codes	38
Self check	38
Troubleshooting chart.....	40
Driving	41
Starting the truck	42
Braking	43
Steering	44
Parking the truck	44
Transporting Loads	45
General.....	45
Use of Pallets on Lift Trucks.....	46
Allowable pallet types:.....	46
Operator procedures:	46
Daily Service/Safety Checks.....	47
General.....	49
Safety regulations with maintenance work	49
Maintenance work that can be carried out by the driver.....	51
Maintenance work that may be carried out by trained maintenance personnel.....	51
Other service and repair work	51
Cleaning and washing.....	52
General.....	52
External cleaning.....	52
Cleaning the motor compartment.....	52
Electrical components	53
Maintenance chart.....	54
Lubrication chart.....	58
Approved oils and grease.....	59
Transporting and Storing the Truck	61
Truck standard dimensions and weights	61
Moving a disabled truck	62
Storing truck.....	63
Battery	63
Hydraulic system	63
Drive unit	63
Starting after a period of disuse	63

Table of Contents

Appendix A, OSHA Regulations.....	64
Appendix B, Battery	68
General prohibition.....	68
General	68
Type of battery	68
Changing the battery.....	68
When changing the battery proceed as follows:	69
Charging the battery	70
General prohibition.....	70
Before charging.....	70
After charging.....	71
Battery maintenance.....	72
Each week:.....	72
Each month:.....	73
Index	74

Safety regulations

Warning symbols

Always follow the warnings given in this Operator's Manual and on the truck to avoid accidents from occurring.

Warning levels

Warning text is given in four levels and provides information on the risks, describe the consequences, and instruct how to avoid accidents.



DANGER

Warns that an accident will occur if you do not follow the instructions.

The consequences are serious personal injury or possibly death, and/or extremely severe material damage.



WARNING

Warns that an accident can occur if the instructions are not followed.

The consequences are serious personal injury or possibly death, and/or severe material damage.



CAUTION

Warns that an accident can occur if the instructions are not followed.

The consequences are personal injury and/or material damage.

NOTE!

Marks the risk of an accident or breakdown if the instructions are not followed.

Safety regulations

Prohibitory symbols



NO SMOKING

If smoking occurs in situations where a restriction against smoking is stated, a serious accident can occur.



OPEN FLAMES PROHIBITED

If open flames are used in situations where open flames are prohibited, a serious accident can occur.



GENERAL PROHIBITION

If the prohibition is ignored, a serious accident can occur.

Ordinance symbols



SAFETY SHOES

When the directive for safety shoes is given, safety shoes shall always be worn to reduce personal injury.



PROTECTIVE GLASSES

When the directive for protective glasses is given, protective glasses shall always be worn to reduce personal injury.

Safety regulations

General safety regulations

Control

- Always carry out the daily service before the truck is used. The working order of all safety equipment, guards, and safety switches should be checked before you use the truck. Such safety equipment must not be disengaged or removed.
- Check to make sure that all warning decals and data plates are clean and undamaged.
- Battery must be secured in its intended compartment. The battery shall have a weight and type that corresponds with the value stated on the truck's data plate. ["Appendix B, Battery" on page 68](#)
- Read the data plate(s). **Do not** operate the truck if there are any differences between the data stated on the data plate and the truck.
- Truck must not be used if it is damaged or has faults that affect safety or its safe use. Only qualified and authorized personnel should maintain, repair, and inspect industrial lift trucks.

Safety regulations

General safety regulations

Operating the truck

- The trucks primary function is for piece and case-picking from elevated locations. It can also be used for transporting loads. It is not designed for placing pallets into or removing pallets from racks.
- If the truck is to be used in cold storage environments the truck must be especially built for this type of use. Ensure there is no build-up of ice on the compartment floor or on the parking brake pedal.
- **Never** allow anyone to stand or walk under any elevated portion of this truck.
- It is **not permitted** to use the truck for other purposes than it has been designed and produced for such as the following applications:
 - In areas where the atmosphere contains gases that can cause fires or explosions.
 - As a towing truck for trailers.
 - To tow other trucks.
 - To transport/lift unauthorized passengers.

Safety regulations

General safety regulations

Operator's responsibility

- Truck shall only be driven by personnel that have been specially trained and that have permission to drive the truck.
- Truck shall only be driven with care, good judgement, and in a responsible manner.
- Each country (state) has its own safety regulations. It is the operator's obligation to know and follow these. This also applies to local regulations and for different types of handling. If the recommendations in this manual deviate from your country's, the local safety regulations should be followed.
- Any accidents or near accidents (incidents) must be reported to your supervisor.
- Local regulations regarding personal safety equipment shall be followed. Do not operate this lift truck unless the safety belt or harness is securely fastened around you. The belt or harness is securely fastened to the tether, and the tether is securely fastened to the overhead guard.
- Truck should not be driven with oily hands or oily shoes due to the risk of slipping.
- **DO NOT** place any part of body between moving and stationary objects.

Safety regulations

General safety regulations

Working area

- If there are marked truck routes these shall be used.
- Truck should only be driven on a dry, clean surface. **Do not** operate on wet, oily surfaces.
- Truck should only be driven on hard and level surfaces.
- Ensure that the floor where the truck is to be used has sufficient load bearing capacity for **total weight** of the truck including the maximum load.
- Take special care if there are protruding parts from racks, shelves, or walls that can cause injury or damage the truck.
- It is forbidden for persons to be present in the area around the truck when there is a risk of personal injury, that is areas that can be reached by falling goods, lowering or falling lifting devices, or in the truck's maneuvering area.
- Grades, ramps, or inclines: This truck is designed for level floor operation only!

Safety regulations

General safety regulations

Driving and conduct while driving

- Always drive the truck from the normal operator position.
- Always drive the truck in a responsible manner and with full control. Sudden starts and braking, as well as cornering at high speed, should be avoided.
- Reduce truck speed if floor surface is slippery to prevent the truck from sliding or overturning.
- Adapt your speed to driving conditions, both to pedestrians and other trucks, in working area. Reduce speed when line of vision is limited and when pedestrians or other vehicles can be encountered. Always yield the right of way to pedestrians.
- Pay particular attention to other personnel, as well as fixed and moving objects, within the working area and thereby avoid accidents.
- Always be prepared to stop if other personnel are in the working area.
- Keep a safe distance from all vehicles ahead.
- Always keep a safe distance from the edges of loading bays and loading ramps. Be attentive to marked risk areas.
- Sound the horn when overtaking other vehicles and when the attention of other personnel is required.
- Always give way to a loaded truck at junctions and in confined aisles.
- **Never** allow unauthorized passengers to ride on truck.

Safety regulations

- **Never** drive with any part of your body outside of the operator position.
- Keep hands and feet clear of controls other than those in use.
- Lift and lower with caution. Make sure there are no obstructions under, or in the path of, the lifting mechanism.
- Make sure the lifting mechanism is operating smoothly.
- Before you drive the truck into an elevator ensure that the elevator is approved for the total weight of the truck, the load, operator, and any other passengers in the elevator. Enter elevator with load first. No other personnel should be in the elevator when the load or truck enters or leaves.
- When the load impairs the line of vision, always drive in the forks trailing direction.
- **DO NOT** run over loose objects, uneven surfaces, or other obstructions on roadway surfaces.
- **DO NOT** smoke or use open flame while working around the truck.
- **DO NOT** tamper with any switch. Doing so could result in severe injury or death.
- Look in the direction of travel and keep a clear view of the path of travel.
- Slow down and sound your horn at cross aisles and wherever vision is obstructed.
- In guided applications, approach and leave guided aisles slowly.

Safety regulations

General safety regulations

Handling loads

- Drive with care when collecting or leaving a load.
- Secure the pallet to the forks with the pallet clamp control.
- Only handle loads that are within the truck's permitted lifting capacity, see truck's data plate. The length and width of the forks shall be adapted to the load's shape and dimensions.
- Only handle loads that are stable and arranged in a safe manner.
- Particular care should be exercised when handling long and tall loads.
- Watch so that overhead obstructions such as lights, pipes, sprinkler systems, etc. are **NOT** contacted.
- The load shall **Only** be lifted vertically and **NEVER** pushed horizontally.
- When transporting loads travel with the lifting mechanism as low as possible.
- When picking loads at elevated heights travel with care.

Safety regulations

General safety regulations

Parking the truck

- Always park in designated areas if available.
- **Never** leave the truck parked with the key still in the key switch.
- **Never** park the truck on an incline.
- **Never** park the truck so that it obstructs emergency exits.
- **Never** park the truck so that it obstructs traffic or work.
- Always park with the forks fully lowered and the brake applied and secured.

Safety regulations

General safety regulations

Handling the battery

- Always handle the battery and its connections with care. Read and follow the instructions for changing or recharging the battery carefully. See chapter [“Appendix B, Battery” on page 68](#).
- Always wear protective glasses when working with the battery.
- Make sure the battery in the truck is of the weight and type that corresponds with the information on the truck’s data plate.
- Make sure the battery is secured in its compartment. [“Appendix B, Battery” on page 68](#)

Safety regulations

General safety regulations

Maintenance and repair

Maintenance instructions should be followed to prevent faults and accidents. See the chapter covering [“Maintenance” on page 49](#). Only qualified and trained personnel are permitted to maintain, adjust, or repair the truck.

All replacement parts shall be Clark approved spare parts.

Modifications and additions which affect capacity and safe operation shall not be performed by the customer or user without manufacturer’s prior written approval. Capacity, operation, and maintenance instruction plate, tags, or decals shall be changed accordingly.

Warning and information decals

Warning and information decals

The figure below shows the position and significance of the decals location on the truck.

1. Warning decal
2. Pinch points: **Do not** reach through uprights
3. **Do not** walk under an elevated load
4. Decal: Fuse
5. Decal: Manual valve lowering knob
6. Decal: ESD grounding point
7. Decal: Brake release bolts
8. Truck data plate

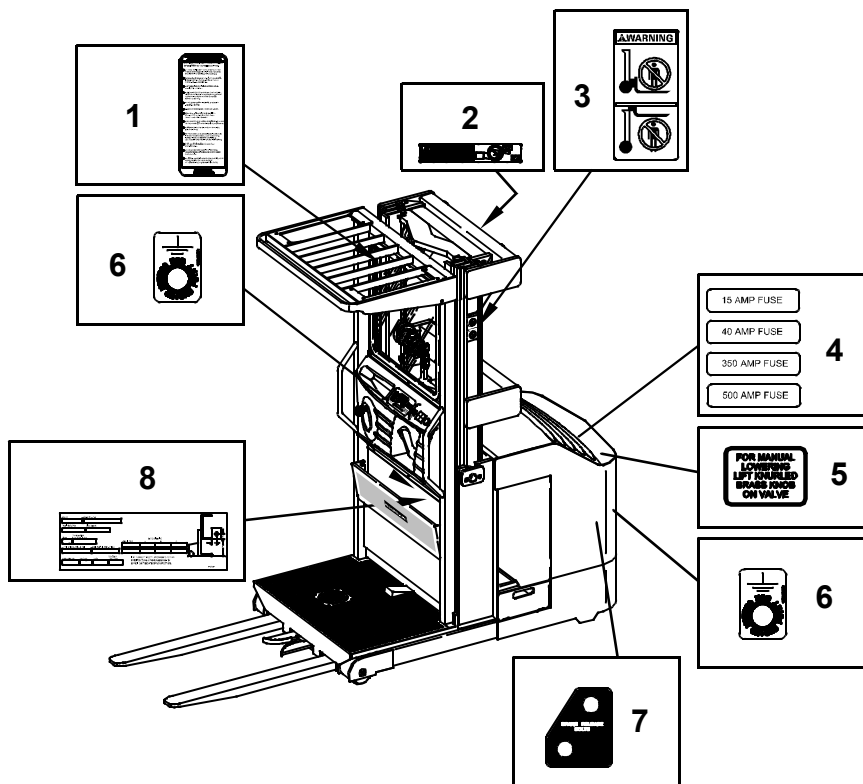

Warning and information decals

Warning decals

Clean or replace all safety and instruction decals that cannot be read.

When you clean decals use only a cloth, soap, and water. **DO NOT** use solvent, gasoline, etc.

You must replace a decal if the decal is damaged, missing, or cannot be read.

If a decal is on a part that is replaced, make sure you install a new decal on the new part. New warning decals can be obtained from your **Clark Dealer**.

Presentation of truck

Presentation of truck

This order picker is intended for picking to a pallet indoors. This truck is operated in a standing position. The truck has available different fork lengths and lifting heights. Refer to the truck's data plate for this information.

The trucks are equipped with a 24 volt electrical system. Travel and lifting speeds are transistor controlled to provide smooth operations. In addition, the travel function and the different hydraulic functions have additional controls which further enhance these features. Different speeds can be set.

Application area for Clark order picker trucks

Clark trucks are solely designed and manufactured to handle goods. This truck should be fitted with the appropriate accessories relevant to the application.

Prohibited applications for Clark order picker trucks

This truck is designed for handling goods indoors. It is not permitted to use this truck for other purposes including the following:

- **Do not** operate in areas that contain gases which can cause fires or explosions
- **Do not** use as a towing truck for trailers
- **Do not** tow other lift trucks
- **Do not** transport or lift passengers
- **Do not** drive on gravel or grass

Presentation of truck

Truck data

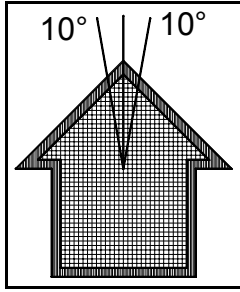

The truck features speed reduction if turned more than 10 degrees either side of center. The table below provides information which is of value with daily use of the truck.

		24 Volt	
		Straight travel	Turned 10° or more
Operating speed without a load	Below 24 inch [Below 600 mm]	6.0 mph [9.7 kph]	
	24 - 60 inch [600 - 1525 mm]	6.0 mph [9.7 kph]	2.5 mph [4.0 kph]
	60 - 150 inch [1525 - 3810 mm]	2.5 mph [4.0 kph]	1.0 mph [1.6 kph]
	150 - 240 inch [3810 - 6095 mm]	1.0 mph [1.6 kph]	0 mph [0 kph]
	Above 240 inch [Above 6095 mm]	0 mph [0 kph]	
Operating speed with classified load	Below 24 inch [Below 600 mm]	5.5mph [8.9kph]	
	24 - 60 inch [600 - 1525 mm]	5.5 mph [8.9 kph]	2.2 mph [3.5 kph]
	60 - 150 inch [1525 - 3810 mm]	2.2 mph [3.5 kph]	1.0 mph [1.6 kph]
	150 - 240 inch [3810 - 6095 mm]	1.0 mph [1.6 kph]	0 mph [0 kph]
	Above 240 inch [Above 6095 mm]	0 mph [0 kph]	

The truck's lifting capacity and weight can be found on the truck's data plate.

Presentation of truck

Truck battery dimensions

Truck battery dimensions

Important

Use only batteries that meet the following specifications:

Compartment Size:

Deep	13.875 inch [350 mm]
Wide	36.25 inch [920 mm]
Height	31.5 inch [800 mm]
Battery Weight	(Consult Data plate on truck)

For smaller industrial battery sizes, provide blocking to restrain the battery from moving not more than 0.5 inch [12.7 mm] in any horizontal direction.

Presentation of truck

OP15X Truck dimensions

The diagrams below shows external dimensions for OP15X.

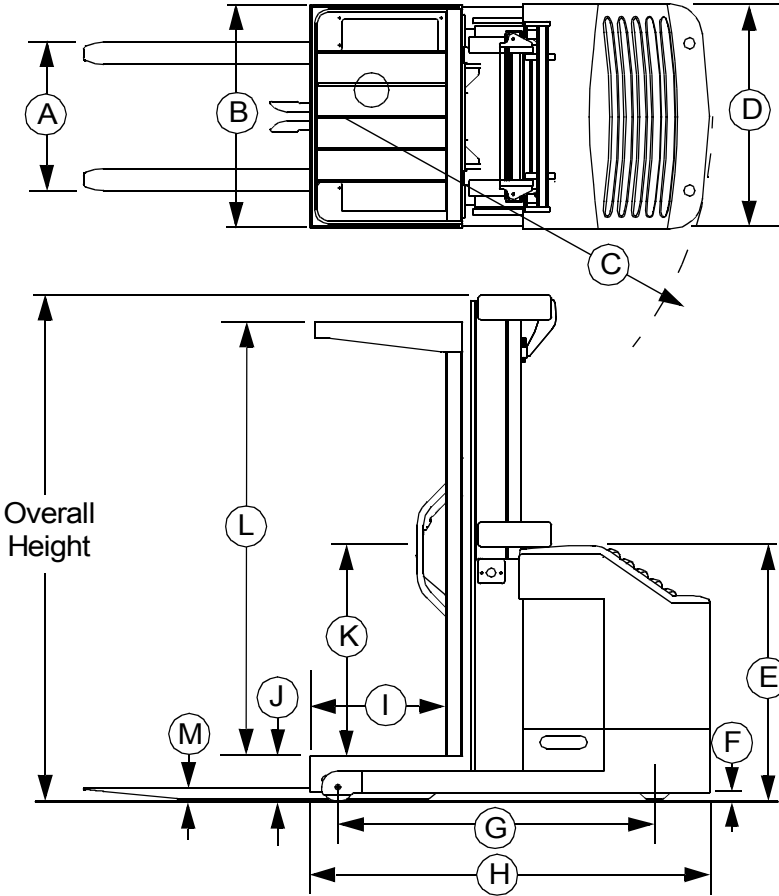

A	23.8 - 28.8 inch [605 - 730 mm]	H	2 Stage 76 inch [1930 mm] 3 Stage 77 inch [1955 mm]
B	40.5 inch [1030 mm]	I	27 inch [685 mm]
C	70 inch [1780 mm]	J	8 inch [200 mm]
D	41 inch [1040 mm]	K	36 inch [915 mm]
E	41 inch [1040 mm]	L	75 inch [1905 mm]
F	2 inch [50 mm]		79 inch [2005 mm]
G	58.2 inch [1480 mm]	M	2.5 inch [65 mm]

Presentation of truck

Data plate

Know the rated capacity on the data plate and understand areas 1 through 13 as shown in the illustration.

1. Truck model number
2. Truck serial number
3. Upright Serial Number
4. Attachment
5. Truck type
6. Weight less battery
7. Minimum battery weight
8. Maximum battery weight
9. Battery maximum AMP hours
10. Hour rate
11. Truck voltage DC
12. Battery type UL class
13. Truck capacity

Model Serial Number

Mast Serial No. Attachment

Truck Weight Less Battery

Batt. Weight (lb (kg)) Batt. Weight, Min. (lb (kg))

Max. Hr. Vol. UL Class

Cap. lb (kg) A B C

inch (millimeter)

THIS FORKLIFT MEETS OR EXCEEDS DESIGN SPECIFICATIONS OF ANSI/ASME B56.1 IN EFFECT ON THE DATE OF MANUFACTURE.

311967-000

Presentation of Main Components

Presentation of main components

1 **Operator controls:**

The steering wheel, instrument panel, and switches (key switch, emergency stop, and light/fan cluster) are on the console cover. The travel speed and direction, hydraulic function, and horn are controlled through the control handle.

2 **Steering wheel**

Steers the truck in a direction of travel.

3 **Steering direction indicator**

Displays the direction the transmission is turned.

4 **Battery level indicator**

Battery level indicator is displayed here.

5 **Key switch**

Shuts off electrical power to control system.

6 **Optional switches**

Controls optional lights and fan from operator's position.

7 **Emergency stop switch**

The emergency stop switch will stop control functions.

8 **Brake pedal**

The brake is applied in the up position.

9 **Pallet clamp**

Applies clamping to retain pallets to lift platform.

10 **Lower switch**

The Operator's platform and forks will lower when switch is rotated or until lower stops are reached.

11 **Raise switch**

The Operator's platform and forks will raise when switch is rotated or until lift stops are reached.

12 **Horn switch**

The horn sounds to warn others of your position.

13 **Travel speed / direction selection**

To select direction rotate in the direction you wish to move. The further in that direction you rotate the faster you move.

14 **Upright**

The upright is a clear view model.

15 **Hydraulic unit**

Pump motor and pump are an integrated unit.

Presentation of Main Components

16 Hydraulic electric solenoid valve

For controlling lifting and lowering function with electric solenoid valve.

17 Fuses

40A, Control fuse part number 934366

350A, Drive fuse part number 934365

500A, Pump fuse part number 934367

18 Drive unit with brake

Drive motor, gears, drive wheel, and electrical brake combined in the drive unit.

19 Electrical steering

A servo steer motor drives a gear ring enabling the drive unit to be rotated through 180 degrees (90 degrees in either direction).

20 Cover and shields

Easily removed and hinged to provide good access for servicing.

21 Electronics

All the electronics are collected in a protected compartment.

22 Gauge

The hourmeter displays the time the brake pedal is depressed.

23 Battery

24V with different capacities and weights.

24 Data plate

Contains data designation, manufacturing number, year of manufacture, service weight, battery weight, classified lifting capacity, battery voltage, and manufacturer. See *"Data plate"* on page 25.

25 Load wheel

Load wheel lube location.

26 Tether line and belt

27 Tether bar

Located on the Operator's overhead guard where the upper end of the tether is secured.

Presentation of Main Components

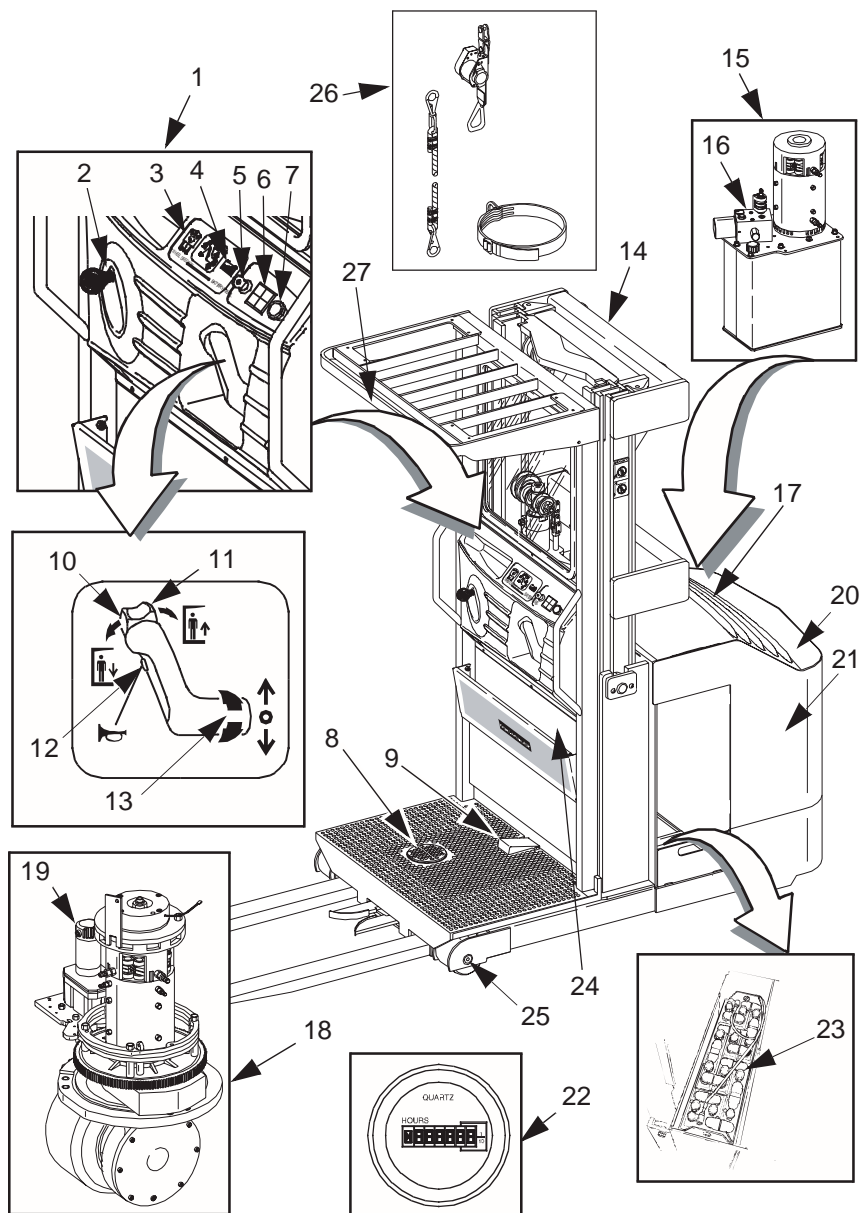

Controls and Instruments

Controls and instruments

Guards and shields have been provided on the unit for your protection.

⚠ WARNING DO NOT operate this equipment unless all factory installed guards and shields are properly secured in place.

Decals are also provided to warn of potential danger as well as to display special operating procedures.

⚠ WARNING Read and observe all warnings on this truck before operating it.

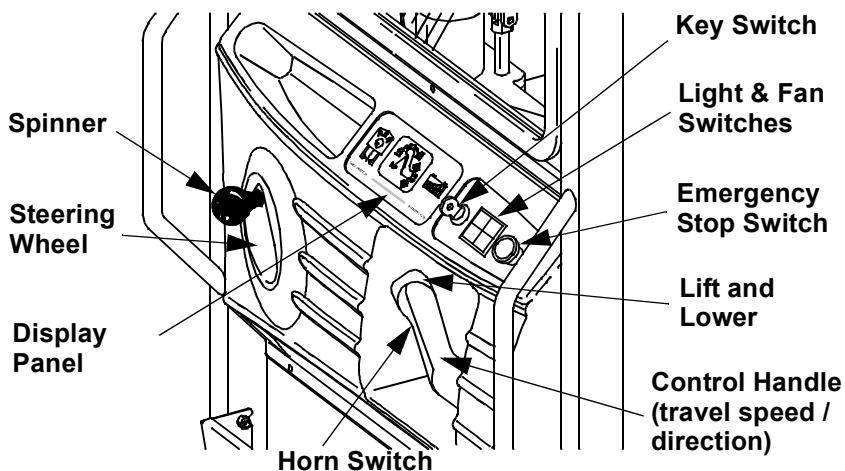

Emergency stop

The truck is fitted with an emergency stop button (red in color), which is located to the right of the key switch on the control console.

Pressing the emergency stop will cut control power supply.

Controls and Instruments

Battery disconnect

In an emergency, first push the emergency stop to **OFF**. This will disable electrical controls. Then disconnect the battery connector, this will cut all electrical power to the truck. Perform all repairs before reconnecting battery.

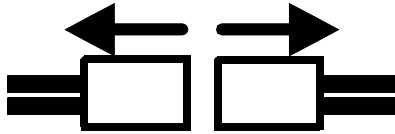

Key switch

The key switch is the main power switch for the control circuit.

When the key switch is turned to the **OFF** position, the power is **OFF** and the display is not lit (however, there is still voltage to some parts of the electronics).

When key switch is turned to the **ON** position, the display will light and current is fed to all electronic components.

Horn control

The horn sounds as long as the switch is pressed.

Directional/Speed control handle

With key switch in the **ON** position and start-up complete, the truck is ready for travel. To **move the truck**, rotate the control handle in the direction you want to move. The more rotation of the control handle, the faster the truck travels.

Stopping is accomplished by two methods. The preferred method, plugging, is achieved by moving the control handle through neutral to the opposite direction of travel. The further the control handle is moved in the opposite direction, the faster the truck will slow. The second method is using the brake pedal. For detailed information see [“Brake pedal”](#) on page 35.

Controls and Instruments

Steering wheel

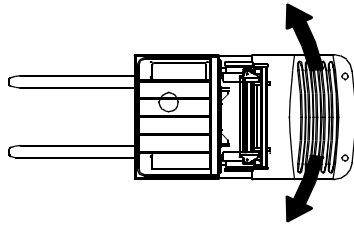

- Steer by means of the steering wheel.
- If the truck gets caught against an obstacle try to free the truck by carefully driving forwards and backwards.



WARNING

Risk of slipping.

You can lose control of the truck if your hands or shoes are oily.

Always dry your hands and shoes before driving.

Hydraulic controls

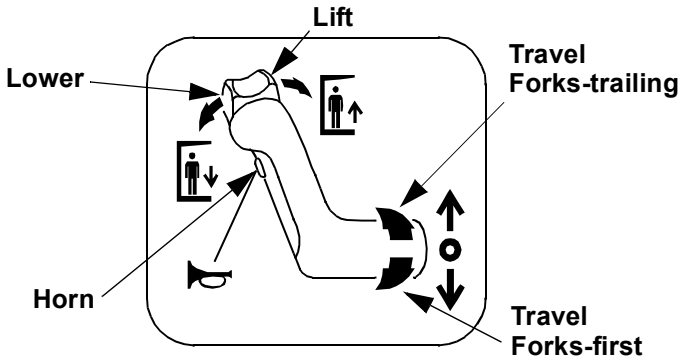

The lift and lower forks thumb knob is on the end of the control handle. Rotating the thumb knob up will lift the forks and rotating the thumb knob down will lower the forks.

NOTE!

No hydraulic functions can be used if the key switch is in the OFF position or if the operator has not depressed the parking brake pedal.

Controls and Instruments

Switches - Lamps and fans

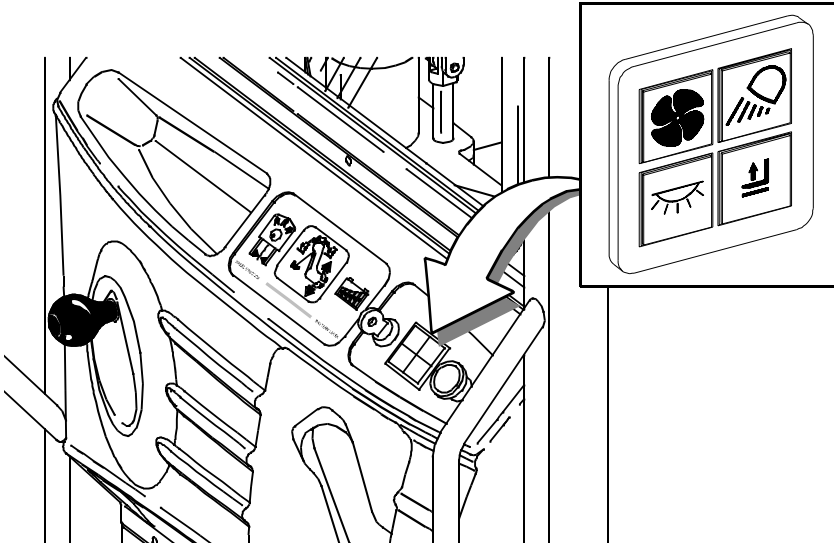

Switches for the lights and fan are located on the control console for easy operator access.

Controls and Instruments

Display

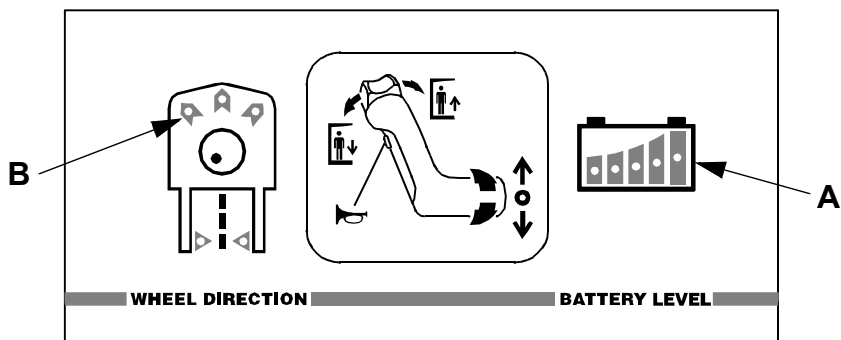

A. Battery Discharge Indicator (BDI)

The BDI measures the state of charge of the battery. The charge is indicated with five LEDs.

Far Right green LED - fully charged battery

Near Right green LED - 3/4 charge battery

Center yellow LED - 1/2 charged battery

Near left yellow LED - 1/4 charge battery

Far right red LED - recharge battery

When the battery is fully charged, the green LED on the far right will be illuminated. As the battery discharges, the illuminated LED will move downward showing the correct discharge level of the battery. When the battery is discharged, the red LEDs on the far left of the BDI will flash alternately to warn the operator that the battery needs recharging and the trucks lift will operate at a reduced speed.

Controls and Instruments

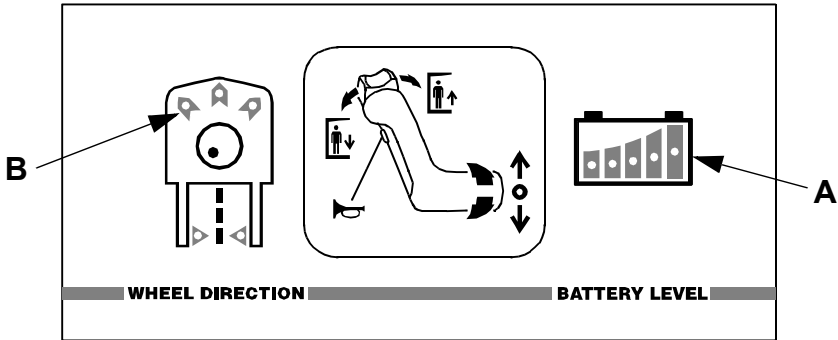

B. Drive wheel indicator

Indicates the position of the drive wheel by one of the arrows in the diagram. The steering indicator has three LEDs (light emitting diodes) that show steering direction based on the drive wheel position. When steering left, the left LED is lit. When steering right, the right LED is lit. When driving straight ahead, the center LED is lit.

Hourmeter

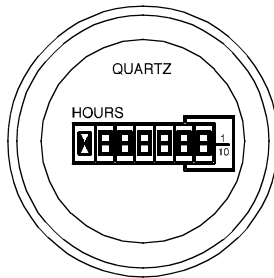

The hourmeter displays the time the brake pedal has been depressed.

Controls and Instruments

Brake pedal

- Place your foot on the brake pedal to release the brake.



WARNING

Risk of crushing exists if any part of the body is outside of the operator's compartment. Always have your entire body inside the operator's compartment.

This truck is equipped with two **stopping methods**. The preferred method, plugging, involves simply reversing the directional/speed control handle to the opposite direction **without** applying the brake. This will cause the truck to come to a stop smoothly. For detailed information on this method of plugging see "*Directional/Speed control handle*" on page 30.

The second **braking method** is achieved by releasing the brake pedal. This is the emergency truck stopping method and should not be used as the way to stop the truck during regular operations.

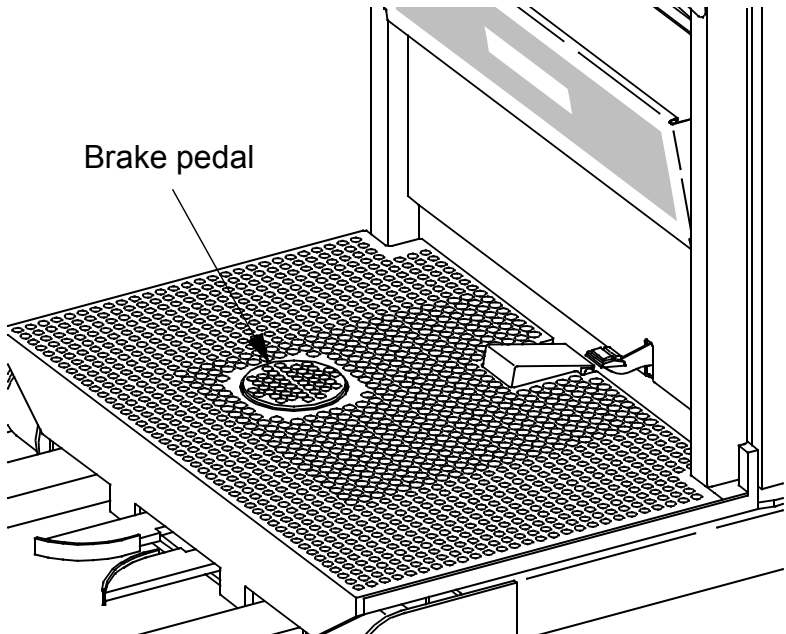

Controls and Instruments

Hydraulic manual release valve

NOTE! The operator should stay on the platform. Another qualified person in the area should manually release the valve.

This truck is equipped with a hydraulic manual release valve located on the hydraulic control valve. When electrical functions do not operate, the platform can be lowered manually. To lower the platform manually, remove the rear cover and twist the release valve 180° counterclockwise. The valve will then pop out and the platform will safely lower to the floor.

NOTE! After safely lowering the platform, push in the valve and twist 180° clockwise to retighten the valve.

Manual
Lowering
Release
Screw

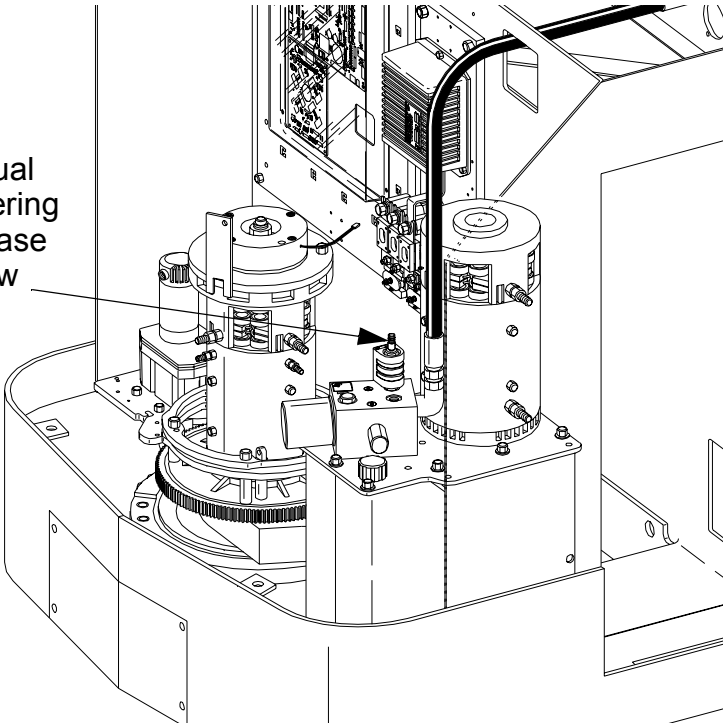

Controls and Instruments

Pallet clamp foot pedal controls

This pallet clamp only works on pallets with a center brace.

Pallet clamp control is used to secure a pallet to the platform. The pallet clamp jaws are physically located between the forks on the platform.

Pallet clamp grip foot control is located in the front and center of lift platform. The pallet clamp release control lever is located below direction control handle on the platform.

To operate pallet clamp controls

1. To clamp pallet, push down on the pallet clamp close foot control to clamp pallet.
2. To release pallet, push down on the pallet clamp open foot control.

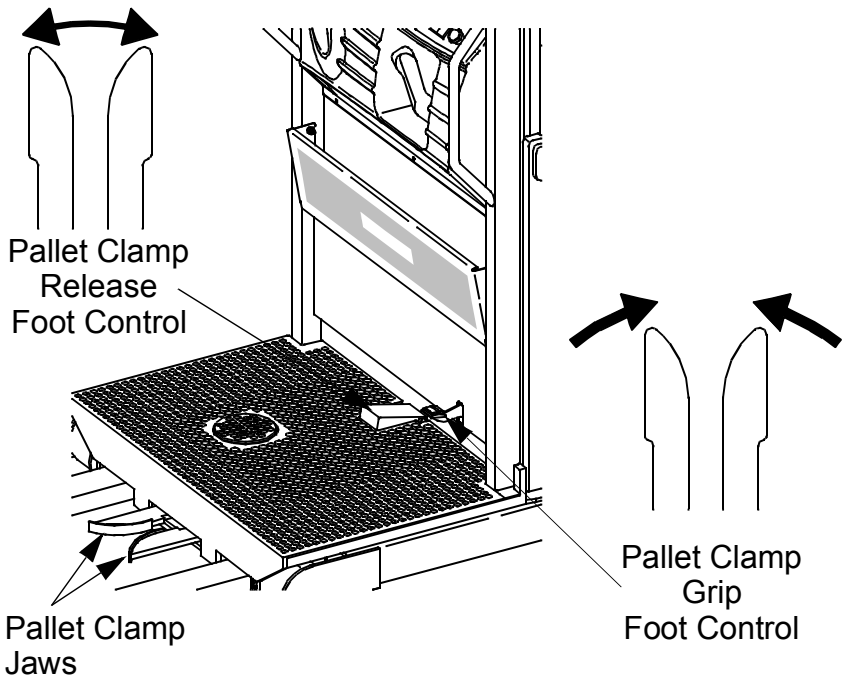

Warning Caution Codes

Self check

Self check occurs whenever the key switch is turned ON. This checks all electrical parts and circuits within the system. If there is a problem, the Display Panel will display a fault code. Self check is complete when the horn beeps three times.

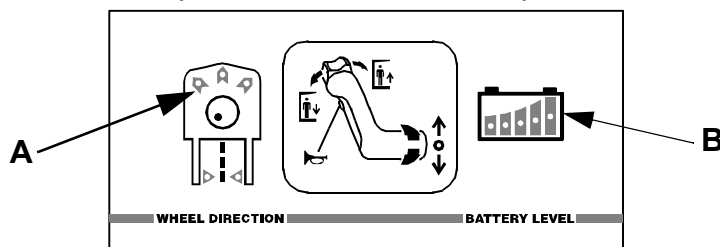

A. Steering indicator

The steering indicator has three LEDs (light emitting diodes) that show steering direction based on the drive wheel position. When steering left, the left LED is lit. When steering right, the right LED is lit. When driving straight ahead, the center LED is lit.

Steering Indicator Messages

Display	Meaning
All LEDs scroll side to side	Drive unit position is unknown
Left LED blinks	Drive unit to left, end-of-travel zone (more than 88° counterclockwise)
Left LED on steady	Drive unit in left zone (5-88° counterclockwise)
Center LED on steady	Drive unit in center zone (within 5° of center)
Right LED on steady	Drive unit in right zone (5-88° clockwise)
Right LED blinks	Drive unit in right end-of-travel zone (more than 88° clockwise)
Left, center and right LEDs blink in unison as the horn chirps	Lift truck is in maintenance mode.

Warning Caution Codes

B. Battery indicator

The battery indicator has five LEDs used in three (3) prioritized modes of operation: 3 is the highest priority.

Battery Indicator Message		
Status Mode	Priority	Display
Fault Code	3 (highest)	Series of blinks for each digit (all 5 blink together). Contact your authorized Dealer.
Info Display	2	Blinks a single LED to indicate a particular condition. See the “Info Display Messages” table below.
Battery-State-of-Charge	1 (lowest)	At full charge, all LEDs are lit. As the battery loses charge, the LEDs turn off from top to bottom

The battery indicator will always show the mode with the highest priority that is active. For example, an info display message will override a battery-state-of-charge message.

Info Display Messages		
LED	Cause	How To Clear
2nd (from top)	Parking brake pedal must be depressed before you request motion.	1. Return controls to neutral. 2. Step on deadman pedal.
	Steering wheel was not turned (initialized) after key switch turned ON.	Turn steering wheel.
3rd	Carriage reached lift or lower limit (if equipped).	Press lift limit bypass switch to continue lifting.
Bottom	Battery charge is low.	Use fully charged battery.

Warning Caution Codes

Troubleshooting chart

The truck display fault codes through the BDI. All LEDs will blink rapidly followed by two groups of slow flashes. Counting the flashes will provide a two digit error code. This LED displays fault codes whenever there is a problem with the controller or the inputs to controller. If the controller detects a fault a 2 digit code is flashed continuously until the fault is corrected. If a fault code persist contact your dealer.

Driving

Driving

There are certain hazards that cannot be avoided solely by mechanical means in the everyday use of material handling trucks. Only intelligence, good sense, and care of the operator, along with proper maintenance, will assure that the trucks are operated properly. It is important to have trained, reliable personnel operating your units. If, at any time, the operator finds that the unit is not performing properly discontinue operation of the truck and report the condition to your supervisor for correction.

The proper operator position for this truck is shown and described below.

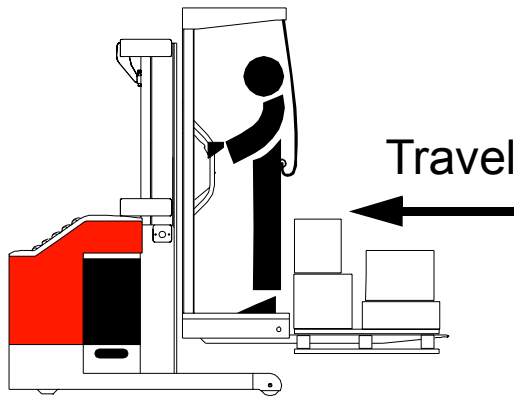

Proper operation of this unit is with forks trailing when possible. Steering the truck is easier with the forks trailing. Always look in the direction of travel.

This unit has been designed for level floor operation and should be operated in accordance with instructions.

Operate the unit from the operator's position after assuring that the operation will not endanger the operator or any other person. Do not operate a truck in hazardous areas. Make sure that the forks and/ or load have clearance to lower and do not "hang-up".

Driving

Starting the truck

- Make sure both battery stops are securely in place and the battery cannot move more than 0.5 inch (12.7 mm) in any horizontal direction.
- Connect the battery to the truck.
- Place the safety belt around your waist and adjust for proper fit. If a harness is used, it should be put on and adjusted per the manufacturer's instructions. Secure the lower end of the tether to the safety belt or harness. Secure the upper end of the tether to the tether bar on the overhead guard.
- Make sure the emergency stop is not pressed in.
- Turn the key switch to the **ON** position (making sure your foot is off the brake pedal for about 2-3 seconds). The instrument lighting should come on.
- Depressing the brake pedal instructs the electrical controller to run a self check. After the checks have been performed the truck is ready to operate.
- Make sure the battery indicator indicates a sufficient charge level.

NOTE!

Low charge level. Prolonged operation with a low battery charge level can result in damage to the battery. Do not drive without first recharging the battery.

 **WARNING** Risk of crushing exists if any part of the body is outside of the operator's compartment. Always have your whole body inside the operator's compartment.

 **WARNING** Always complete the daily operator's checks before starting the day's work.

Driving

⚠ WARNING Accidents can occur. Always drive with care, good judgment, and responsibility.

- To stop the lift truck in an emergency, release the brake pedal immediately. Releasing the pedal disables travel and applies the parking brake to stop the lift truck in the shortest possible distance.

Braking

The brake is applied when the pedal is in the raised position. Depressing the pedal releases the brake and closes the control circuit allowing operation of the truck. Operation of the brake should always be checked before operating the truck.

This truck is equipped with two **stopping methods**. The preferred method, plugging, involves simply reversing the directional/speed control handle to the opposite direction **without** applying the brake. This will cause the truck to come to a stop smoothly. Refer to [“Directional/Speed control handle” on page 30](#) for detailed information on this method. The second **stopping method** is achieved by releasing the brake pedal. Refer to [“Brake pedal” on page 35](#) for detailed information.

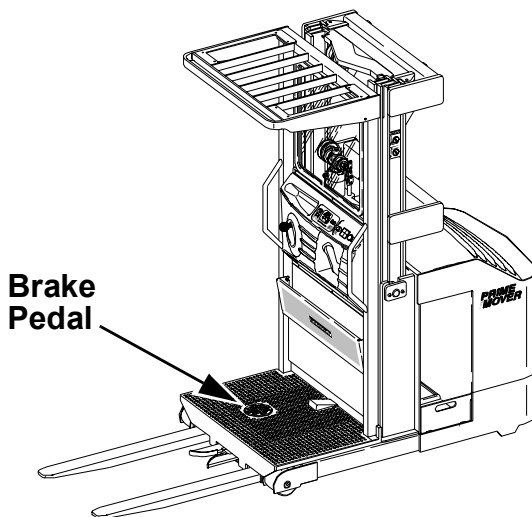

Driving

Steering

The steering signal is transmitted to an electric steering motor mounted in the motor compartment. The steering motor moves the transmission by means of gears.

 **WARNING** The truck and/or load can become unstable if the steering is turned quickly at high speed.

 **WARNING** Risk of slipping. Control of the truck can be lost if your hands or shoes are oily. Always dry your hands and shoes before driving.

Parking the truck

- Stop the truck carefully and make sure that all motion has stopped.
- Lower the forks/platform to the floor.
- Apply the parking brake by releasing the brake pedal. The parking brake is automatically applied.
- Turn the key switch to the **OFF** position and remove the key.

 **WARNING** Unauthorized use. Accidents can happen. Always remove the key from the key switch when truck is left unattended.

Transporting Loads

Transporting loads

General

The weight of the load should be within the truck's permitted lifting capacity. See "[Data plate](#)" on page 25.

 **WARNING** Risk of overturning. The lifting capacity is reduced if additional equipment is attached to the truck. Always check the truck data plate for the truck's overall lifting capacity.

- Only handle loads that are stable and arranged safely. Take particular care when handling high and long loads.

 **WARNING** Lost stability. High loads can fall when cornering at high speed or cause the truck to tip over. Drive slowly and carefully when cornering and travel with loads in lowered position.

 **WARNING** Protruding loads. The load can collide with personnel, fixed or moving objects. A truck with a protruding load requires more room when cornering.

- Drive the truck in the forks-trailing direction when the load impairs the line of vision.
- If necessary, when the operator's vision is impaired, ask someone to direct operations so that transportation can take place without the risk of causing personal injury or material damage.

 **WARNING** Risk of overturning. A truck can overturn when attempting to turn on an incline. Never operate a truck on an incline.

Transporting Loads

Use of Pallets on Lift Trucks

When a pallet is used for order picking, the attached pallet is not a work platform, but rather a place to temporarily set materials being retrieved or stored. When placing material on a pallet, it is often necessary for the operator to place one foot on the pallet to reach the back surface.

Allowable pallet types:

- Double-faced pallet with a center stringer that allows the pallet clamp to securely fasten the pallet to the platform.
- Pallet that is in good repair, having no broken or missing boards and no loose connections or fasteners between pallet components
- Wood or plastic pallets that conform to the above

Operator procedures:

- The pallet clamp has securely fastened the pallet to the lift truck.
- The operator must use the safety belt and tether.

When stepping on the pallet, the operator places one foot on that portion of the pallet location between the fork blades, not on the edge of the pallet.

Daily Service/Safety Checks

Daily service/safety checks

- The operator is responsible for the daily service and care of the truck.
- Carry out the daily service at the start of the each day or shift, **before** the truck is used. The daily service is a simple safety and function control check indicated in the list below.
- No tools are needed to carry out the service checks.
- Failure to carry out the daily service can affect the safety and reliability of the truck.



WARNING

Never neglect the daily service and safety checks, accidents can occur. Always report any faults or damage to your supervisor without delay. Never use a truck that does not function properly.

Check points	Action
Hydraulic system	Check for oil leakage, hoses and floor.
Lifting device	Check for damage, noise function.
Battery cables and connections	Check for breakage cutting or damage.
Battery retainer plates	Check correct location.
Chassis and upright	Check for damage, remove dirt and debris.
Overhead guard & safety guards	Check for damage, ensure placement.
Drive unit	Inspect abnormal noises and leakage.
Wheels	Check for damage, remove oil, metal chips and debris.

Daily Service/Safety Checks

Check points	Action
Decals	Check for damage ensure decals can be read.
Safety belt/harness and tether line	Check for damage or wear.
Brake pedal	Check function.
Direction / accelerator	Check function.
Control handle	Check functions. Check for freedom of movement.
Hydraulic function	Check function.
Control functions	Check function.
Parking brake	Check function.
Horn	Check function.
Running time	Inform your supervisor if your truck is ready for a schedule maintenance check. See <i>"Maintenance"</i> on page 49.
Emergency stop	Check function.
Steering	Check function.
Windshield	Check for damage
Special equipment (i.e. travel alarm, lights, wire guidance, etc.)	Your truck may have been fitted with optional or special equipment that requires routine check to ensure safe operation. Consult with your supervisor and Prime-Mover representative about routine checks.

If any of the functions fail to operate properly, inform your supervisor or maintenance personnel to have the truck repaired.

 **WARNING** DO NOT operate the truck when it is not functioning properly.

Maintenance

Maintenance

General

- Ensure the truck is given a regular maintenance service after every 720 driving hours. The truck's safety, efficiency, and service life is dependent on the service and maintenance it is given.
- Only use **Clark** approved spare parts when service and repair work are carried out.
- Contact your **Clark** dealer to setup a service and maintenance agreement to ensure the truck is operating properly.

Safety regulations with maintenance work

- Only personnel that have been trained in the service and repair of this type of truck are authorized to carry out service and repair work.
- Do not carry out any maintenance work on the truck unless you have the correct training and knowledge to do so.
- Keep the area where you carry out service clean. Oil or water makes the floor slippery.
- Never wear loose objects or jewelry when working on the truck.



WARNING

Short-circuiting/burns. When working with the truck's electrical system, short circuiting/burns can occur if a metal object comes into contact with live electrical connections. Remove watches, rings, or other types of metal jewelry.

- Always switch **OFF** the truck's power supply before opening the covers on the drive unit or electrical systems.

Maintenance

- Always disconnect the battery by pulling out the battery connector when carrying out maintenance work on the truck unless otherwise stated in this publication or the SM-714 **Service Manual**.
- Lower operator's platform to the ground and relieve the system pressure slowly before starting work on the truck's hydraulic systems.
- Use paper or a rigid sheet of cardboard when checking for oil leakage. **Never** use your hand.
- Bear in mind that the oil in the transmission or the hydraulic system can be **hot**.

 **WARNING** Risk of burns. Hot transmission and hydraulic oil. Let the truck cool before changing the oil.

- Only fill the hydraulic system with new, clean oil which meets cleanliness specification [See "Lubrication chart"](#) on page 58. Contact your Clark representative for assistance or more information.

 **WARNING** The hydraulic system and hydraulic components can be damaged if the oil is contaminated. Always use new and clean oil in the hydraulic system.

- Store and dispose of changed oil in accordance with local regulations.
- **Do not** dump solvents used for cleaning or washing into drains that are not intended for this purpose. Follow the local regulations that apply for disposal.

Maintenance



WARNING Risk of crushing. A badly supported truck can fall. Never work under a truck.

Maintenance work that can be carried out by the driver

The **Daily service/Safety checks** as set out in the check list.

Maintenance points with intervals **1 day**, **1 week**, and **1 month** as set out in the **Maintenance chart** may be carried out by the driver without more knowledge than that provided by the **Operator's Manual**. (See "*Maintenance chart*" on page 54.)

Other maintenance points as set out in the **Maintenance chart** may only be carried out by personnel who have completed maintenance training for this type of truck.

Maintenance work that may be carried out by trained maintenance personnel

All maintenance points as set out in the **Maintenance chart**.

If you are uncertain regarding working procedures, consult the **Service Manual** for the truck.

Other service and repair work

In addition to the maintenance points in the **Maintenance chart**, all service and repair work should be carried out by personnel with special training for this type of truck.

Maintenance

Cleaning and washing

General

Cleaning and washing of the truck is important to ensure the truck will operate safely and reliability.

NOTE! Risk of short circuiting. The electrical system can be damaged. Disconnect the battery before washing by pulling out the battery connector. Do not spray water directly into the electrical compartments of the truck.

External cleaning

- Remove debris, etc. from the wheels daily.
- Use a degreasing agent, diluted to a suitable concentration.

NOTE! Mechanical components can be damaged. After washing, the truck should be lubricated. See *“Lubrication chart”* on page 58.

Cleaning the motor compartment

- Cover the electric motors, electrical compartments, connectors, and valves before washing.
- Clean carefully using the minimum of water and detergent. **Never pressure wash** or **steam clean** in the compartments.

Maintenance

NOTE! Risk of short-circuiting. The electrical system can be damaged. Electrical components must not be cleaned with a high pressure washing unit.

Electrical components



- Blow electric motors dry using compressed air.

⚠ WARNING Compressed air used for cleaning **MUST** be reduced to less than 30 psi (206 kPa) and then only with effective chip-guarding and personal protective equipment.

- Clean the electrical panels, electronic boards, contacts, connector, solenoid valves, etc. using a damp cloth and a cleaning agent.
- **Do not spray or pressure wash** in the compartment.

NOTE! Risk of short-circuiting.
Electrical components can be damaged.
Do not break warranty seal on electronic components.

Maintenance

Maintenance chart

Planned Maintenance Interval:

A=8 Hours or 1 Day

B=30 Hours or 1 Week

C=120 Hours or 1 Month

D=360 Hours or 3 Months

E=720 Hours or 6 Months

F=1440 Hours or 12 Months

G=4320 Hours or 36 Months

No.	Action	A	B	C	D	E	F	G
1.0	Chassis							
1.1	Check that truck's data plate is legible	X						
1.2	Check door latch					X		
1.3	Check wear on battery stop					X		
1.4	Check for damage and crack formation					X		
1.5	Check forks frame mounting					X		
2.0	Motors							
2.1	Check for loose connections					X		
2.2	Clean motor blow out dust			X		X		
2.3	Check mounting bolts			X				
2.4	Check for abnormal bearing noise			X		X		
2.5	Check brush wear					X		
3.0	Drive unit							
3.1	Check for leakage			X		X		
3.2	Check oil level					X		
3.3	Check for noises					X		
3.4	Check the mounting bolts				X			
4.0	Wheels							
4.1	Remove string and debris	X						
4.2	Check drive wheel wear and nuts					X		
4.3	Check that the support arm wheels rotate and axles are fitted correctly					X		
4.4	Check support arm wheels for wear					X		

Maintenance

No.	Action	A	B	C	D	E	F	G
4.5	Dismantle and lubricate the support wheel bearing							X
5.0	Brake							
5.1	Clean					X		
5.2	Check for wear to the brake discs					X		
5.3	Check for play in released position					X		
5.4	Check brake wires for wear					X		
6.0	Electrical panel							
6.1	Clean and check the mounting					X		
6.2	Tighten cable connections					X		
6.3	Check contactor points					X		
6.4	Check the contactor's movement					X		
6.5	Check connections and routing of harness					X		
6.6	Warning light	X						
7.0	Battery							
7.1	Check the electrolyte level 1/4 inch [10-15 mm] above cell plate		X					
7.2	Check the connections on battery, truck and charger		X					
7.3	Check cell and pole guard			X				
7.4	Check the fluid density and temperature			X				
7.5	Check power cables are not cut or frayed	X						
8.0	Hydraulic system							
8.1	Check hoses and couplings for leakage					X		
8.2	Check pipes and hoses for wear					X		
8.3	Check the hydraulic tank for leakage and its mountings					X		
8.5	Check oil level					X		
8.6	Change oil						X	

Maintenance

No.	Action	A	B	C	D	E	F	G
9.0	Cylinders							
9.1	Check for leakage					X		
10.0	Upright and platform							
10.1	Check for damage and cracks					X		
10.2	Check upright mounting bolt torque					X		
10.3	Check for play on the rollers					X		
10.4	Check the electrical limit switch function					X		
10.5	Check for wear and stretch on the chains and sheaves					X		
10.6	Check hoses and couplings for leakage cuts and other damage					X		
10.7	Check for wear to the forks and other lifting devices		X					
10.8	Check OHG for physical damage	X						
11.0	Control console							
11.1	Check for control handle freedom of movement and that it returns to neutral when released	X						
11.2	Check the micro switches and hydraulic function	X						
12.0	Pedal							
12.1	Check the pedal function	X						
13.0	Emergency stop switch							
13.1	Check the emergency stop switch	X						
14.0	Windshield/Screen							
14.1	Check for breakage/damage	X						
15.0	Check belt and tether							
15.1	Check for breakage/damage	X						
16.0	Decals							
16.1	Check that all decals are readable	X						

Maintenance

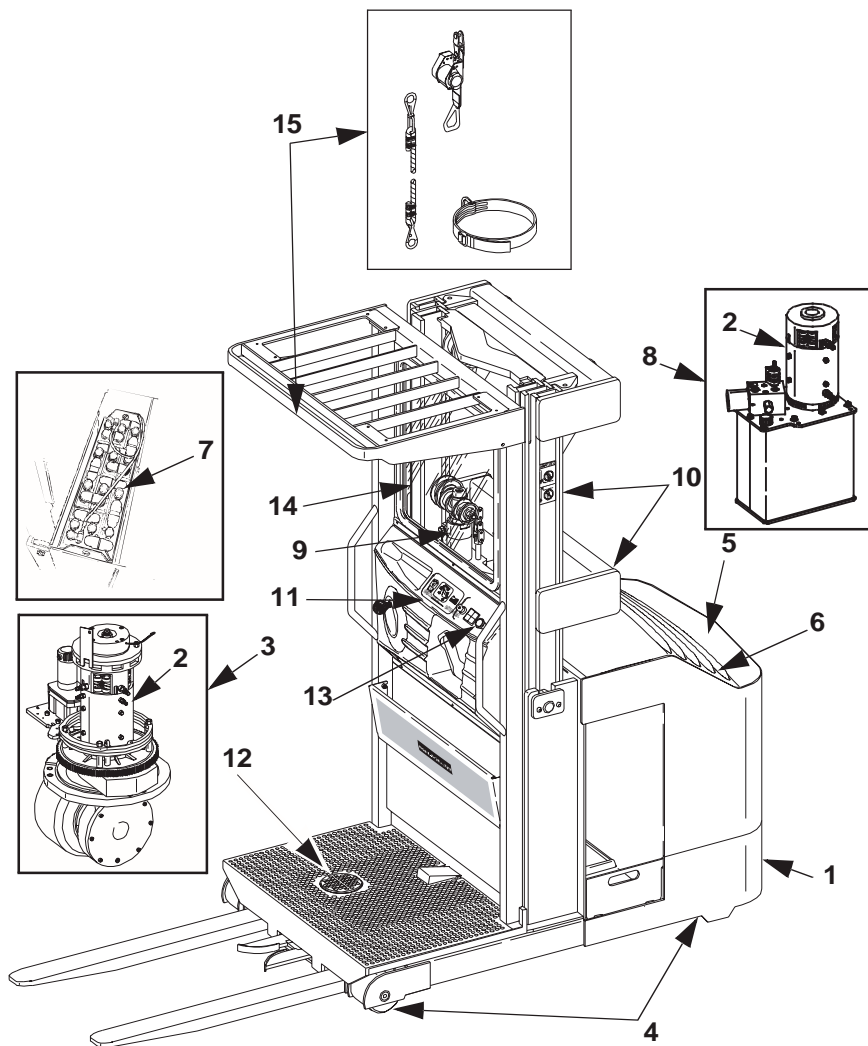

Maintenance

Lubrication chart

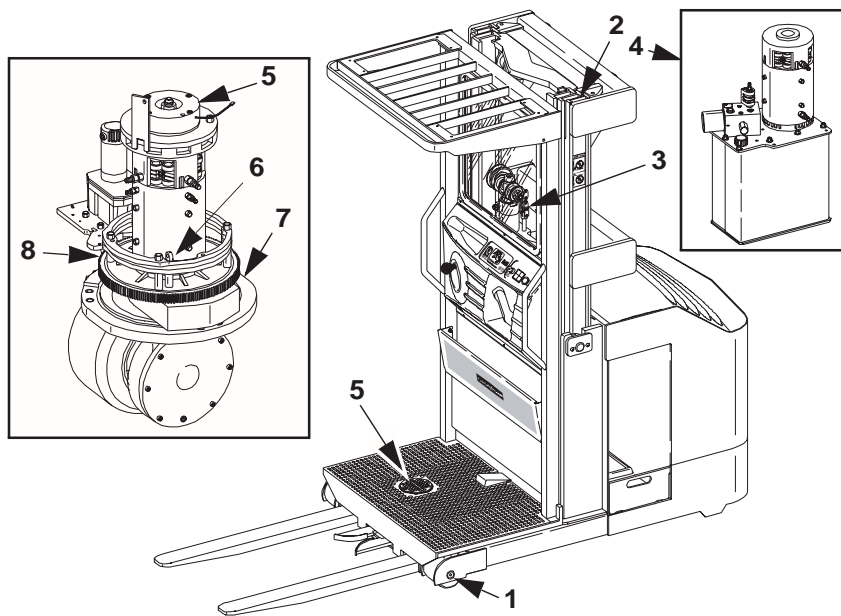

Pos. No.	Service point	Interval/Running hours			Lubricant
		720 h	1440 h	4320 h	
1	Wheel bearings			L	A
2	Upright Beam	L			F
3	Lifting chains	L			D
4	Hydraulic system	C	O		B
5	Brake	C			
6	Drive gear	C		O	C
7	Steering bearings		L		A
8	Gear ring	L			A

L=Lubrication

C=Check

O=Oil change

Maintenance

Approved oils and grease

Specification					
Location	Lubricant	Standard and Corrosion	Cold Storage	Freezer	Application area
		Continuous Operation Above 40°F [5°C]	Continuous Operation To 14°F [-10°C] Intermittent Operation To -4°F [-20°C]	Continuous Operation To -20°F [-29°C]	
A	Grease	Mystik JT-6		Mobiltemp SHC 32	Bearings and bushings
B	Hydraulic oil	1801708	1802154	Texaco 15	Hydraulic system
C	Transmission oil	Valvoline Heavy Duty Synthetic Gear Lube 75W90			Gears
D	Motor oil	886399			Chains
E	Grease	886396			Mast rails

Maintenance

Environmental Definitions	
Standard	Trucks parked in ambient temperature area when not in use and charging and maintenance work.
Corrosion	Where a damp, wet, or corrosive condition exists.
Cold Storage Continuous Operation	Trucks completely dry prior to entering the continuous-stay in the cold store. Park inside cold storage for operator breaks. Charging and maintenance work done outside cold storage. Truck completely dry before returning to continuous cold store.
Cold Storage Intermittent Operation	Surface condensation will occur, "wet" trucks should neither remain idle in cold store for longer than 10 minutes nor operate inside cold store for extended periods. Condensation must not be allowed to freeze on truck at any time. Park outside cold store for operator breaks Charging and maintenance work done outside cold store.
Freezer Condition	Truck parked inside freezer for operator breaks Trucks stays in freezer during battery charging or change-out. If truck is removed from freezer for maintenance work or battery charging, it must be completely dry before reentering the continuous shift in the freezer.

Transporting and Storing the Truck

Transporting and storing the truck

Truck standard dimensions and weights

NOTE! The truck dimensions and weights can vary with different accessories.

Truck dimensions and weights	
Battery Width	24 Volt 36.25 inch [920 mm]
Height, truck without upright/OHG	83 inch [2110 mm] 87 inch [2210 mm]
Width, dependent on outrigger	41 inch [1040 mm]
Length [excluding forks]	2 Stage 76 inch [1930 mm]
Minimum battery weight	1500 lb. [680 kg]
Service weight without battery with 95/210 inch [2413/5334 mm] upright	4390 lb. and Up [1990 kg and Up]

Transporting and Storing the Truck

Moving a disabled truck

WARNING Be sure to remove the brake release bolts from the brake and return to storage location before operating truck again.

To safely move a disabled truck.

1. Lower the operator platform and remove any load.
2. Turn the key switch to the OFF position and disconnect the battery connector.
3. Remove drive compartment cover and open door, install brake release bolts in the brake.
4. Tighten brake release bolts until brake is released. This will allow truck to be moved without damaging the drive tire.

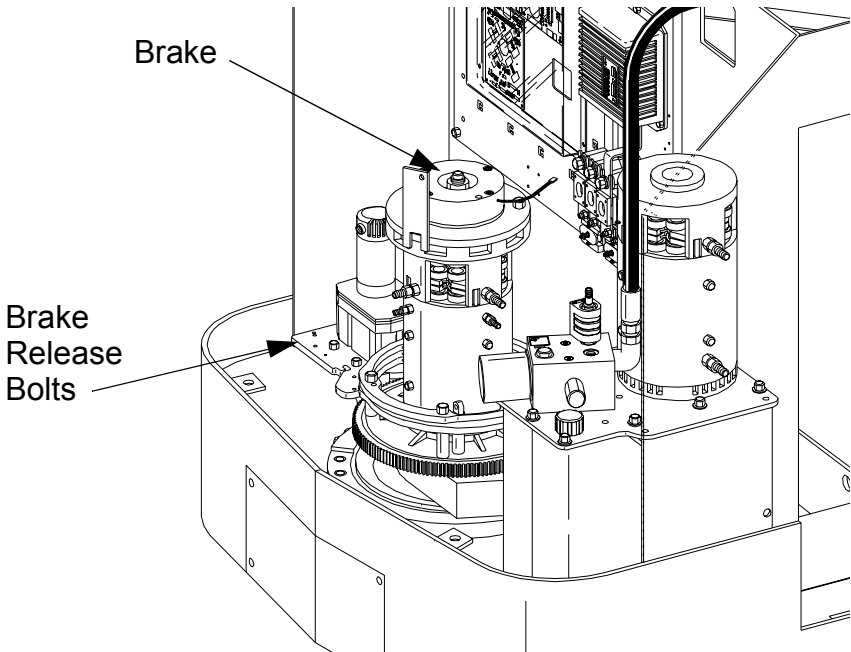

Transporting and Storing the Truck

Storing truck

Take the following action if the truck is not used for **one week** or more:

Battery

- Recharge the battery fully and carry out usual battery maintenance.
- Maintenance charge the battery every **3rd month** and check the fluid level.

Hydraulic system

Change the oil in the hydraulic system when stored for periods longer than **1 year**, see the oil specification in the [“Lubrication chart”](#) on page 58.

Drive unit

Block up the truck’s drive section to take the load off the drive wheel and load wheels when storing for periods longer than **one week**.

Starting after a period of disuse

- Before the truck is put into operation after a period of disuse, it should undergo a function and safety check as stated in the [“Daily service/safety checks”](#) on page 47.
- When stored for a period **greater** than **3 months**, carry out preventive maintenance as stated in the instructions, **350 hours interval**.

Appendix A, OSHA Regulations

APPENDIX A, OSHA Regulations

The use of forklift trucks in the workplace is governed by various regulations. In the United States, the Department of Labor Occupational Safety and Health Administration (OSHA) has issued regulations which cover the majority of workplaces. In addition, several states have implemented regulations which apply instead of the Department of Labor regulations. Check with your local OSHA office or provincial Labor Bureau to confirm which regulations govern your workplace. Because of their wide applicability, this section of your manual lists several parts of the Department of Labor OSHA regulations which may be of particular importance to your workplace. The full text of the Department of Labor regulations may be found in the Code of Department of Labor Regulations at 29 CFR Section 1910.178. The selections cited below and on the next page are followed by a reference to the appropriate subparagraph of the regulations.

- Modifications and additions which affect capacity and safe operation shall not be performed by the customer or user without manufacturers prior written approval. Capacity, operation and maintenance instruction plates, tags or decals shall be changed accordingly. (a) (3)
- The user shall see that all nameplates and markings are in place and are maintained in a legible condition. (a) (6)
- The employer shall ensure that each powered industrial truck operator is competent to operate a powered industrial truck safely, as demonstrated by the successful completion of the training and evaluation specified in this paragraph. (l) (1) (i)
- Prior to permitting an employee to operate a powered industrial truck (except for training purposes), the employer shall ensure that each operator has successfully completed the training required by this paragraph. (l) (1) (ii)

Appendix A, OSHA Regulations

- Trainees may operate a powered industrial truck only under the direct supervision of persons who have the knowledge, training, and experience to train operators and evaluate their competence and where such operation does not endanger the trainee or other employees. (l) (2) (i) (A) (B)
- Training shall consist of a combination of formal instruction (e.g. lecture, discussion, interactive computer learning, videotape, written material), practical training (demonstrations performed by the trainer and practical exercises performed by the trainee), and evaluation of the operator's performance in the workplace. (l) (2) (B) (ii) (**Editorial Note:** For required Training program content, refer to (l) (3) (i) (A-M) and (l) (3) (ii) (A-I).)
- Refresher training, including an evaluation of the effectiveness of that training, shall be conducted as required by paragraph (l) (4) (ii) to ensure that the operator has the knowledge and skills needed to operate the powered industrial truck safely. (l) (4) (i)
- An evaluation of each powered industrial truck operator's performance shall be conducted at least once every three years. (l) (4) (iii)
- The employer shall certify that each operator has been trained and evaluated as required by this paragraph (l). The certification shall include the name of the operator, the date of the training, the date of the evaluation, and the identity of the person(s) performing the training or evaluation. (l) (6)
- The employer shall prohibit arms or legs from being placed between the uprights of the mast or outside the running lines of the truck. (m) (4)

Appendix A, OSHA Regulations

- Brakes shall be set and wheel blocks shall be in place to prevent movement of trucks, trailers or railroad cars while loading or unloading. Fixed jacks may be necessary to support a semitrailer when the trailer is not coupled to a tractor. The flooring of trucks, trailers, and railroad cars shall be checked for breaks and weakness before they are driven into. (m) (7)
- Only approved industrial trucks shall be used in hazardous locations. (m) (11)
- All traffic regulations shall be observed, including authorized plant speed limits. A safe distance shall be maintained approximately three truck lengths from the truck ahead, and the truck shall be kept under control at all times. (n) (1)
- The driver shall be required to slow down and sound the horn at cross aisles and other locations where vision is obstructed. If the load being carried obstructs forward view, the driver shall be required to travel with the load trailing. (n) (4)
- Under all travel conditions the truck shall be operated at a speed that will permit it to be brought to a stop in a safe manner. (n) (8)
- Stunt driving and horseplay shall not be permitted. (n) (9)
- If at any time a powered industrial truck is found to be in need of repair, defective, or in any way unsafe, the truck shall be taken out of service until it has been restored to safe operating condition. (p) (1)
- Any power-operated industrial truck not in safe operating condition shall be removed from service. All repairs shall be made by authorized personnel. (q) (1)
- All parts of any such industrial truck requiring replacement shall be replaced only by parts equivalent as to safety with those used in the original design. (q) (5)

Appendix A, OSHA Regulations

- Industrial trucks shall be examined before being placed in service, and shall not be placed in service if the examination shows any condition adversely affecting the safety of the truck. Such examination shall be made at least daily. Where powered industrial trucks are used on a round-the-clock basis, they shall be examined after each shift. Defects when found shall be immediately reported and corrected. (q) (7)

Appendix B, Battery

Appendix B, Battery



General prohibition

When recharging the battery it is absolutely forbidden to smoke or use an open flame.



ALWAYS WEAR PROTECTIVE GLASSES AND PROTECTIVE GLOVES WHEN CHECKING THE BATTERY.

General

Battery must be secured in its intended compartment making sure battery cannot move more than 0.5 inch (12.7 mm) in any horizontal direction. Shim or block to restrain the battery. The battery shall have a weight and type that corresponds with the value stated on the truck's data plate.

Type of battery

Check that the battery used in this truck is the correct voltage and type as shown on the truck's data plate. Use a motive power battery having a weight within the minimum/maximum values stated on the data plate.

Changing the battery

Replace the battery only with a battery of the same weight as the original. The battery weight affects the truck's stability and its braking capacity. Information on the lowest permitted battery weight and type can be found on the truck's data plate.

⚠ WARNING Risk of moving the center of gravity. A battery weight that is too low gives impaired stability and braking capacity. Battery weight must be in accordance with the information on the truck's data plate.

Appendix B, Battery

When changing the battery proceed as follows:

- Park truck at battery removal station.
- Turn **OFF** key and remove.
- Push the master control on/off switch to the **OFF** position to stop hourmeter from running.
- Disconnect the battery connector from the truck and remove battery retainer.
- Slide out the discharged/old battery, then slide in the new battery and install battery retainer(s). Make sure battery cannot move more than 0.5 inch (12.7 mm) in any horizontal direction. Shim or block to restrain the battery.
- Connect battery and truck connectors.

NOTE!

Risk of short-circuiting.
The cables can be damaged and cause a short-circuit.
Ensure the battery cables are not crushed.

- Put the master control on/off switch to the **ON** position.



WARNING

Falling battery.
If truck should tip over, battery can fall out if battery retainers have not been installed.
Make sure the battery retainers have been installed.

Appendix B, Battery

⚠ WARNING Falling battery.
When changing the battery, it can be dropped.
Always move battery using an approved device.

Charging the battery



General prohibition

When recharging the battery it is absolutely forbidden to smoke or use an open flame.

⚠ WARNING Corrosive acid.
The battery fluid contains sulfuric acid. Fluid spilled on skin should be rinsed OFF immediately. Wash thoroughly with soap and water.
If the fluid has come into contact with the eyes, wash the eyes immediately using an eye shower. Contact a doctor.



ALWAYS WEAR PROTECTIVE GLASSES AND PROTECTIVE GLOVES WHEN CHECKING THE BATTERY.

Before charging

- Park the truck in the assigned charging area.
- Ensure nothing prevents ventilation above the battery.
- Turn key switch to the **OFF** position.
- Remove the battery connector from the truck's connector.
- Make sure the battery charger is switched **OFF**.

Appendix B, Battery

- Connect the **battery connector to charger** connector.
- **Never** connect charger connector to truck connector.
- Follow the battery and charger manufacturer's instructions before charging the battery.



WARNING

During the charging process, oxygen and hydrogen gases are always formed in the battery.

Short circuits, open flames, and sparks in the vicinity of the battery can cause an **EXPLOSION**.

Always switch **OFF** the charger current **BEFORE** removing the battery connector.

Provide good ventilation, especially if the battery is recharged in a confined area.

After charging

- Ensure the battery charging is complete and charger is off.
- Disconnect the battery connector from charger connector.

NOTE!

Risk of short circuiting.

The terminals can otherwise be damaged inside and result in a subsequent short circuit.

Do not pull the cables to disconnect from the charger.

Appendix B, Battery

Battery maintenance

Battery maintenance should only be performed by a qualified person and according to instructions of battery manufactures.

⚠ WARNING Corrosive acid.
Battery fluid contains sulfuric acid. Fluid spilled on skin should be rinsed OFF immediately. Wash thoroughly with soap and water.
If the fluid has come into contact with the eyes, wash the eyes immediately using an eye shower. Contact a doctor.



ALWAYS WEAR PROTECTIVE GLASSES AND PROTECTIVE GLOVES WHEN CHECKING THE BATTERY.

Each week:

- Remove all cell caps.

NOTE! This does not apply to batteries with level caps or central filling.

- Check the fluid level in the cells and note any cells that consume more than a normal amount of fluid.
- Fill using distilled water. The fluid level should be 0.25 inch (10-15 mm) above the cell plates.
- Refit all of the cell caps.
- Rinse off and dry the battery.

Appendix B, Battery

Each month:

- Measure the temperature in one of the center cells immediately after charging. The temperature should not exceed 122°F (50°C).
- Measure the density of the battery fluid using an acid tester. Hold the acid tester absolutely vertical and extract sufficient fluid so that the hydrometer float moves freely.
- Adjust specific gravity with temperatures based on the chart below.

Temperature	Gravity
77°F (25.2°C)	1.280



WARNING Battery manufactures maintenance and charging procedures must be followed. Battery acid is very corrosive and must be immediately cleaned up after spillage.

Index

A

Appendix A, OSHA Regulations	64
Appendix B, Battery	68
Applications, acceptable	21
Applications, prohibited	21

B

Battery	27
Battery maintenance	72
Each month	73
Each week	72
Changing the battery	68
Charging the battery	70
After charging	71
Before charging	70
General prohibition	70
General	68
General prohibition	68
Type of battery	68
When changing the battery proceed as follows	69
Battery level indicator	26
Battery specifications	23
Before operating truck	1
Brake pedal	26, 35

C

Controls	
Battery disconnect	30
Directional/Speed	30
Emergency stop	29
Horn	30
Hydraulic controls	31
Key switch	30
Plug braking	43
Steering wheel	31
Stopping	30
Switches - Lamps and fans	32
Cover and shields	27

D

Daily Checks	
Battery cables and connections	47

Index

Battery retainer plates	47
Brake pedal	48
Chassis and mast	47
Control functions	48
Control handle	48
Decals	48
Direction / accelerator	48
Drive unit	47
Emergency stop	48
Horn	48
Hydraulic function	48
Hydraulic system	47
Lifting device	47
Overhead guard & safety guards	47
Parking brake	48
Running time	48
Safety belt/harness and tether line	48
Special equipment	48
Steering	48
Wheels	47
Windshield	48
Data plate	27
Dimensions and capacities	3
Dimensions, truck	24
Drive unit with brake	27
Driving	
Parking the truck	44
Plug braking	43
E	
Electrical steering	27
Electronics	27
Emergency stop switch	26
F	
Foreword	2
Fuses	27
G	
Gauge	27
General safety regulations	10
Maintenance and repair	18
Operating the truck	10

Index

Ordinance symbols	8
Parking the truck	16
Working area	12
H	
Horn switch	26
Hydraulic electric solenoid valve	27
Hydraulic manual release valve	36
Hydraulic unit	26
I	
Instruments	
Battery Discharge Indicator (BDI)	33
Drive wheel indicator	34
Hourmeter	34
Operator display	33
K	
Key switch	26
L	
Load wheel	27
Lower switch	26
M	
Mast	26
N	
Note	31, 52, 53, 61, 69, 71, 72
Notice	1
O	
Operator controls	26
Optional switches	26
P	
Pallet clamp	26
Pallet clamp foot pedal controls	37
Plug braking	43
R	
Raise switch	26
S	
Self check	38
Battery indicator	39

Index

Steering indicator	38
Troubleshooting chart	40
Specifications	
Battery	23
Standard Compliance	3
Steering direction indicator	26
Steering wheel	26
Storage	
Battery	63
Drive unit	63
Hydraulic system	63
Starting after period of disuse	63
Symbols	
Caution	7
Danger	7
General prohibition	8
No Smoking	8
Note	7
Open flames prohibited	8
Protective glasses	8
Safety shoes	8
Warning	7

T

Tether bar	27
Tether line and belt	27
Transporting	
Disabled truck	62
Travel speed / direction selection	26
Truck	
Application	21
Applications, prohibited	21
Dimensional data	24
Presentation	21
Truck specifications	23

W

Warning	1, 29, 31, 35, 44, 45, 47, 48, 49, 50, 51, 53, 62, 68, 69, 70, 71
-------------------	--

Additional copies of this operator's manual may be purchased from your Clark dealer.

**Clark Material Handling Company
2317 Alumni Park Plaza, Suite 500
Lexington, KY
40517-4288
Phone: 859-422-6400
Phone (Toll Free): 866-252-5275
www.clarkmhc.com**
