

---

# Operator's Manual

Do not remove this manual  
from the truck.

---

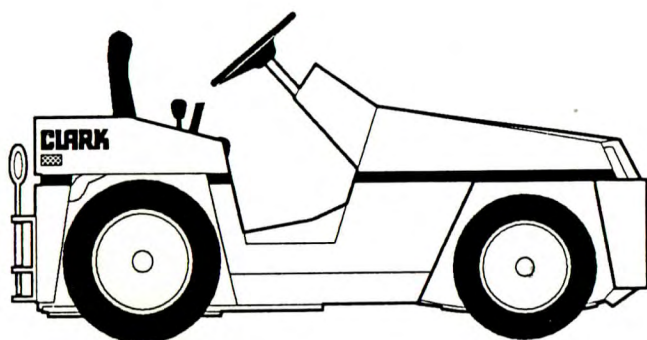

GTDT 30/60E

---

**CLARK**

Book No. 2810045  
OM-607

Record the following information pertaining to your truck

Record the following information pertaining to your truck.

Model No. \_\_\_\_\_  
Serial No. \_\_\_\_\_  
Customer Truck Identification No. \_\_\_\_\_  
Truck Weight, Empty \_\_\_\_\_  
Truck Rated Capacity \_\_\_\_\_  
Truck Gross Weight \_\_\_\_\_  
Truck Gross Weight, Loaded w/ Rated Load \_\_\_\_\_  
Special Equipment or Attachments \_\_\_\_\_

### IMPORTANT

**Do not expose this manual to hot water or steam.**

The following warnings are provided pursuant to California Health & Safety Code Sections 25249.5 et. seq:

 <b>WARNING</b>
<b>California Proposition 65</b> This product contains and emits chemicals known to the State of California to cause cancer, birth defects and other reproductive harm.

<b>CALIFORNIA</b> Proposition 65 Warning Diesel engine exhaust and some of its constituents are known to the State of California to cause cancer, birth defects or other reproductive harm.
---

 <b>WARNING</b>
The engine exhaust from this product contains chemicals known to the State of California to cause cancer, birth defects or other reproductive harm.

# Operator's Manual

You must be trained and authorized to operate a tow tractor.

## YOU can prevent accidents

First: Learn safe operating rules and your company rules.

Next: Read your Operator's Manual. If you do not understand it, ask your supervisor for help.

Learn about the unit you operate.



## KNOW YOUR TOW TRACTOR

Then: Practice operating your tractor safely.

And: Keep your tractor in safe operating condition with correct and timely maintenance.

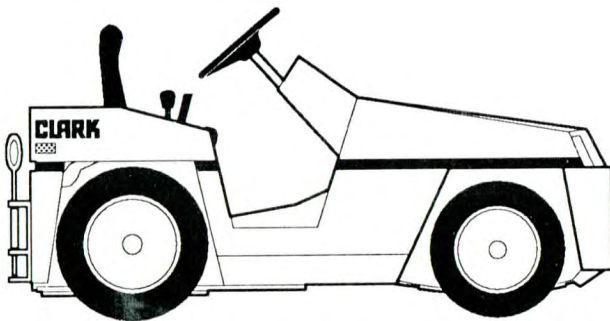

**Breaking these rules will cause serious or fatal injury to yourself and others**

---

## A Message to CLARK Tow tractor Operators

Tow Tractors are specialized machines with unique operating characteristics, designed to perform a specific job. Their function and operation is not like a car or ordinary tractor. They require specific instructions and rules for safe operation and maintenance.

Safe operation of tow tractor is of primary importance to CLARK. Our experience with tow tractor accidents has shown that when accidents happen and people are killed or injured, the causes are:

- **Operator not properly trained**
- **Operator not experienced with tow tractor operation**
- **Basic safety rules not followed**
- **Tow tractor not maintained in safe operating condition**

For these reasons, CLARK wants you to know about the safe operation and correct maintenance of your tow tractor.

This manual is designed to help you operate your tow tractor safely. This manual shows and tells you about safety inspections and the important general safety rules and hazards of tow tractor operation. It describes the special components and features of the tractor and explains their functions. The correct operating procedures are shown and explained. Illustrations and important safety messages are included for clear understanding. A Section on maintenance and lubrication is included for the tow tractor mechanic.

The operator's manual is not a training manual. It is a guide to help trained and authorized operators safely operate their tow tractor by emphasizing and illustrating the correct procedures. However, it cannot cover every possible situation that may result in an accident. You must watch for hazards in your work areas and avoid or correct them. It is important that you know and understand the information in this manual and that you know and follow your company safety rules! Be sure that your equipment is maintained in a safe condition. Do not operate a damaged or malfunctioning tractor. Practice safe operation every time you use your tow tractor. Let's join together to set high standards in safety.

Remember, before you start operating this tow tractor, be sure you understand all driving procedures. It is your responsibility, and it is important to you and your family, to operate your tow tractor safely and efficiently. Be aware that the Federal Occupational Safety and Health Act (OSHA) and state laws require that operators be completely trained in the safe operation of lift trucks; it is also an (OSHA) requirement that a machine inspection be performed before every shift. If you think you need training in operating or inspecting your tow tractor, ask your supervisor.

CLARK lift trucks are built to take hard work, but not abuse. They are built to be dependable, but they are only as safe and efficient as the operator and the persons responsible for maintaining them. Do not make any repairs to this tractor unless you have been trained in safe tow tractor repair procedures and are authorized by your employer.



## Contents of this Manual

This manual covers the following models:

GT 30-60E and DT 30-60E

<b>A Message to CLARK Tow Tractor Operators .....</b>	<b>ii</b>
<b>Introduction .....</b>	<b>vi</b>
How to Use this Manual .....	viii
Safety Signs and Safety Messages .....	x
<b>Section 1. General Safety Rules .....</b>	<b>1-1</b>
<b>Section 2. Know Your Tow Tractor .....</b>	<b>2-1</b>
<b>Section 3. Operator Maintenance and Care .....</b>	<b>3-1</b>
<b>Section 4. Starting and Operating Procedures .....</b>	<b>4-1</b>
<b>Section 5. Emergency Towing and Starting .....</b>	<b>5-1</b>
<b>Section 6. Planned Maintenance .....</b>	<b>6-1</b>
<b>Section 7. Specifications .....</b>	<b>7-1</b>
<b>Index .....</b>	<b>Index-1</b>

---

## Introduction

CLARK welcomes you to the growing group of professionals who own, operate, and maintain CLARK lift trucks. We take pride in the long tradition of quality products and superior value the CLARK name represents. This manual familiarizes you with safety, operating, and maintenance information about your new tow tractor. It has been specially prepared to help you use and maintain your CLARK tow tractor in a safe and correct manner.

Your CLARK tow tractor has been designed and built to be as safe and efficient as today's technology can make it. As manufactured, it meets all the applicable mandatory requirements of ANSI B56.9-1992 Safety Standard for Operator Controlled Industrial Tow Tractors. Each tractor is also furnished with equipment to help you operate safely; for example, parking brake and horn are standard equipment.

Safe, productive operation of a tow tractor requires both skill and knowledge on the part of the operator. The operator must know, understand, and practice the safety rules and safe driving and load handling techniques described in this manual. To develop the skill required, the operator must become familiar with the construction and features of the tow tractor and how they function. The operator must understand its capabilities and limitations, and see that it is kept in a safe condition.

### **Routine Servicing and Maintenance**

Regular maintenance and care of your tow tractor is not only important for economy and utilization reasons; it is essential for your safety. A faulty tow tractor is a potential source of danger to the operator, and to other personnel working near it. As with all quality equipment, keep your tow tractor in good operating condition by following the recommended schedule of maintenance.



## **Operator Daily Inspection — Safety and Operating Checks**

A tow tractor should always be examined by the operator, before driving, to be sure it is safe to operate. The importance of this procedure is emphasized in this manual with a brief illustrated review and later with more detailed instructions. CLARK dealers can supply copies of a helpful "Drivers Daily Checklist."

## **Planned Maintenance**

In addition to the daily operator inspection, CLARK recommends that a planned maintenance and safety inspection program (PM) be performed by a trained and authorized mechanic on a regular basis. The PM will provide an opportunity to make a thorough inspection of the safety and operating condition of your tow tractor. Necessary adjustments and repairs can be done during the PM, which will increase the life of components and reduce unscheduled downtime and increase safety. The PM can be scheduled to meet your particular application and tow tractor usage.

The procedures for a periodic planned maintenance program that covers inspections, operational checks, cleaning, lubrication, and minor adjustments are outlined in this manual. Your CLARK dealer is prepared to help you with a Planned Maintenance Program by trained service personnel who know your tow tractor and can keep it operating safely and efficiently.

## **Service Manual**

In-depth service information for trained service personnel is found in *Service Manual SM607*

---

## How to Use this Manual

This manual is a digest of essential information about the safe operation, the features and functions and explains how to maintain your tow tractor. This manual is organized into seven major parts:

**Section 1, General Safety Rules**, reviews and illustrates accepted practices for safe operation of a tow tractor.

**Section 2, Know Your Tractor**, describes the major operating components, systems, controls, and other features of your tractor and tells how they function.

**Section 3, Operator Maintenance and Care**, presents details on how to perform the operator's daily safety inspection and refuel the tractor.

**Section 4, Starting and Operating Procedures**, discusses specific instructions on the safe, efficient operation of your tow tractor.

**Section 5, Emergency Towing and Starting**, gives instructions for towing your tractor in an emergency and for using battery jumper cables to start your tow tractor in an emergency.

**Section 6, Planned Maintenance**, describes the PM program.

**Section 7, Specifications**, provides reference information and data on features, components, and maintenance items.

Also, the **Index** helps you locate information about various topics.

**NOTICE:** The descriptions and specifications included in this manual were in effect at the time of printing. CLARK Material Handling Company reserves the right to make improvements and changes in specifications or design, without notice and without incurring obligation. Please check with your authorized CLARK dealer for information on possible updates or revisions.

The examples, illustrations, and explanations in this manual should help you improve your skill and knowledge as a professional tow tractor operator and take full advantage of the capabilities and safety features of your new tow tractor.

The first Section of the manual is devoted to a review, with illustrations and brief messages, of general safety rules and the major operating hazards you can encounter while operating a tow tractor. Next, you will find descriptions of the components of your specific tow tractor model and how the instruments, gauges, and controls operate.

You will find a discussion of safe and efficient operating procedures, followed by instructions on how to tow a disabled tow tractor. The later sections of the manual are devoted to maintenance and tractor specifications.

Take time to carefully read the "Know Your Tractor" section. By acquiring a good basic understanding of your truck's features, and how they function, you are better prepared to operate it both efficiently and safely.

In "Planned Maintenance," you will find essential information for correct servicing and periodic maintenance of your tractor, including charts with recommended maintenance intervals and component capacities. Carefully follow these instructions and procedures.

Each major Section has its own table of contents, so that you can find the various topics more easily. If you cannot find a topic in the table of contents, check the index at the back of the manual.

We urge you to first carefully read the manual from cover to cover. Take time to read and understand the information on general safety rules and operating hazards. Acquaint yourself with the various procedures in this manual. Understand how all gauges, indicator lights, and controls function. Please contact your authorized CLARK dealer for the answers to any questions you may have about your lift truck's features, operation, or manuals.

Operate your tow tractor safely; careful driving is your responsibility. Drive defensively and think about the safety of people who are working nearby. Know your truck's capabilities and limitations. Follow all instructions in this manual, including all IMPORTANT, CAUTION, WARNING, and DANGER messages to avoid damage to your tow tractor or the possibility of any harm to yourself or others.

This manual is intended to be a permanently attached part of your tow tractor. Keep it on the tractor as a ready reference for anyone who may drive or service it. If the tractor you operate is not equipped with a manual, ask your supervisor to obtain one and have it attached to the tractor. And, remember, your CLARK dealer is pleased to answer any questions about the operation and maintenance of your tow tractor and will provide you with additional information should you require it.

---

## Safety Signs and Safety Messages

Improper operation can cause accidents. Don't take chances with incorrect or damaged equipment. **Read and understand** the procedures for safe driving and maintenance outlined in this manual. Don't hesitate to ask for help. **Stay alert!** Follow safety rules, regulations, and procedures. Avoid accidents by recognizing dangerous procedures or situations before they occur. **Drive and work safely** and follow the safety signs and their messages on the tractor and in this manual.

**Safety signs and messages** are placed in this manual and on the tractor to provide instructions and identify specific areas where potential hazards exist and special precautions should be taken. Know and understand the meaning of these instructions, signs, and messages. Damage to the tractor, death, or serious injury to you or other persons may result if these messages are not followed. If warning decals are damaged, they must be replaced. Contact your CLARK dealer for replacements.

### NOTICE

This message is used when special information, instructions or identification are required relating to procedures, equipment, tools, pressures, capacities and other special data.

### IMPORTANT

This message is used when special precautions should be taken to ensure a correct action or to avoid damage to or malfunction of the tractor or a component.



### CAUTION

This message is a reminder of safety practices that can result in personal injury if proper precautions are not taken.



### WARNING

This message indicates a hazard exists that can result in injury or death if proper precautions are not taken.



### DANGER

This message is used when an extreme hazard exists.

## General Safety Rules

### Index

Daily Inspection .....	1.2
Do's and Don'ts .....	1.3
No Riders .....	1.4
Pedestrians .....	1.4
Operator Protection .....	1.5
Parking .....	1.6
Safety Procedures .....	1.7

## Daily Inspection

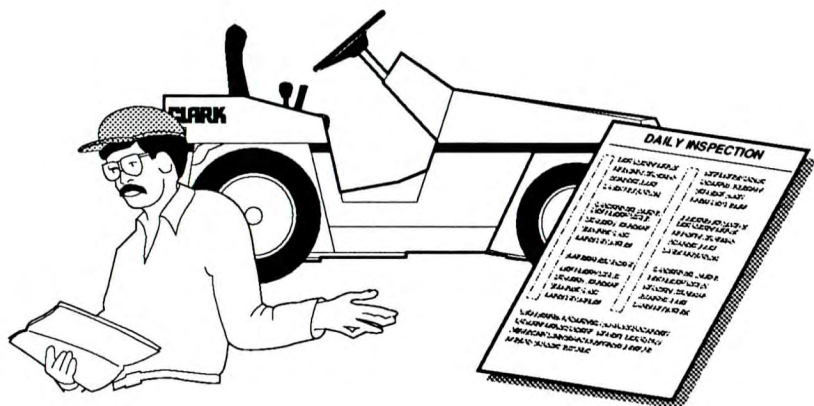

At the beginning of each shift, inspect your tractor and fill out a daily inspection sheet.

Check for damage and maintenance problems.

Have repairs made before you operate the tractor.



### CAUTION

**Do not make repairs yourself. Trained mechanics are professionals. They know how to make repairs safely.**

**Do's and Don'ts**



**Don'ts mix drugs or alcohol with your job.**

**Do watch for pedestrians.**



**Don'ts block safety or emergency equipment**

**Do wear safety equipment when required.**



**Don'ts smoke in "NO SMOKING" areas or when refueling.**

---

## No Riders

The operator is the only one who should be on a tractor unless a passenger seat is provided.

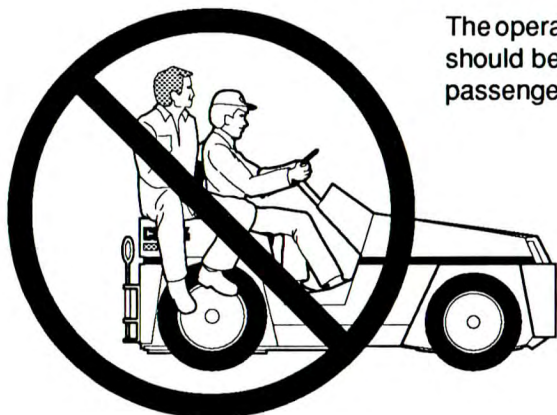

## Pedestrians

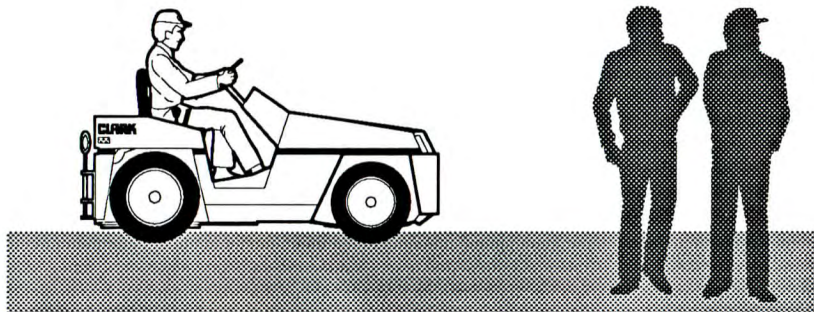

Watch where you are going, look in the direction of travel. Pedestrian may use the same roadway you do. Sound your horn at all intersections or blind spots.



### CAUTION

**Watch for people in your work area even if your tractor has warning lights or alarms. They may not hear you or watch for you. Make people stand back, even when you are parked.**



## Operator Protection

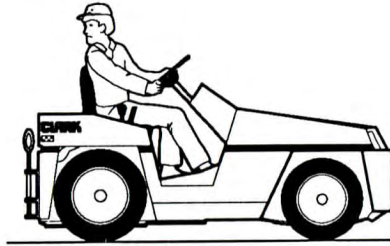

**CAUTION**

**Be especially careful when traveling in reverse and maneuvering in tight areas.**

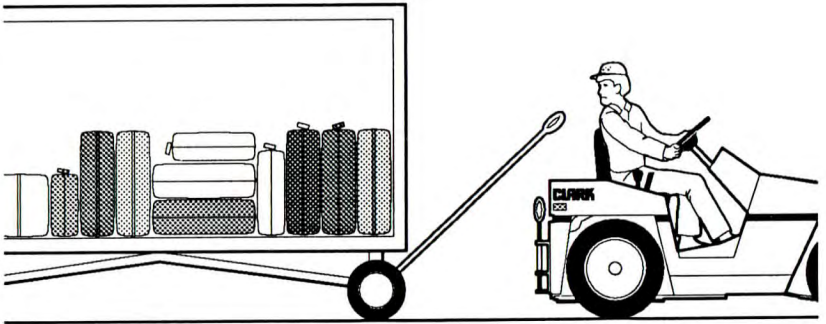

**CAUTION**

**Watch out for intrusions into the operators compartment.**

## Parking

Never park on a grade

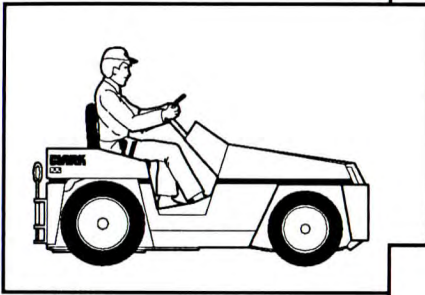

Before leaving your tractor:  
Always come to a complete  
stop...

AND  
Be sure shifter is in  
park or neutral...

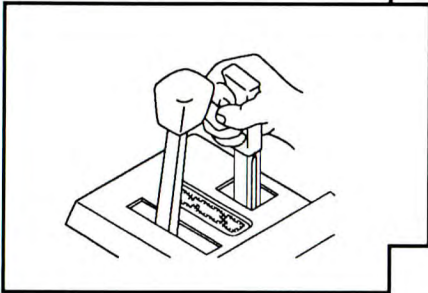
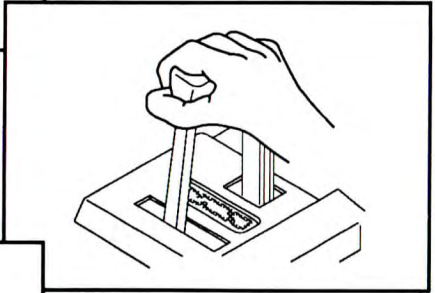

AND  
Set parking brake...

AND  
Turn key to "OFF" position.

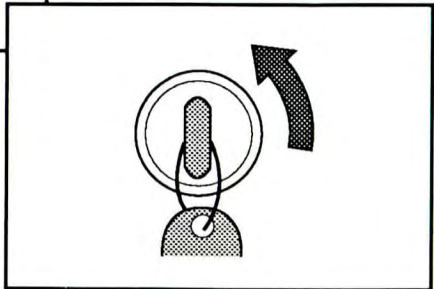

## Summary of Safe Operating Procedures

1. Do not operate this tractor unless you have been trained and authorized to do so. Read all warnings and instructions in operator's manual and on this tractor.
2. Do not operate this tractor until you have checked its condition. Give special attention to tires, horn, lights, battery, brakes, steering mechanism, fuel system, and guards.
3. Operate tractor only from designated operating position. Never place any part of your body outside of the confines of the tractor. Do not carry passengers unless a passenger seat has been provided.
4. Make sure the tow coupler is secure.
5. Do not handle unstable or loosely stacked loads. Use special care when handling long, high or wide loads to avoid losing the load, striking bystanders, or tipping the tractor. Loads on trailers must be evenly distributed and secure.
6. Tow tractors generally tow loads in excess of the tractors weight. A loaded tractor-trailer requires increased stopping distance.
7. Start, stop, travel, steer and brake smoothly. Slow down for turns on uneven or slippery surfaces that could cause tractor to slide or overturn. Violent application of brakes is dangerous and may cause "jack-knifing" of trailers.
8. When making a turn, allow for "corner-cutting" of the trailer.
9. When moving in reverse direction with a trailer, get assistance if vision is obstructed. Moving in reverse direction with more than one trailer is not recommended.
10. Make sure correct tire pressures are maintained.
11. Before driving over a dockboard or bridge plate, make sure it is correctly secured. Drive carefully and slowly across the dockboard or bridge plate, and never exceed its rated capacity with tractor or trailers.
12. Do not run over objects on the traveled surface.
13. Use special care when operating on ramps—travel slowly, and do not angle or turn.
14. If a tractor must be parked on an incline, put blocks at the wheels.
15. Fumes from operation of any powered tow tractors in poorly ventilated areas can be deadly. Turn engine off when not in use.

- 
16. Observe applicable traffic regulations. Yield right-of-way to pedestrians, slow down and sound horn at cross aisles and whenever vision is obstructed.
  17. Make a report of all accidents involving personnel, building structures, and equipment to the correct authority.
  18. Before getting off tractor, neutralize direction control and set parking brake. When leaving tractor unattended, turn the ignition circuit off.

# Know Your Tow Tractor

## Contents

<b>Tow Tractor Model Description .....</b>	<b>2-2</b>
<b>Data/Safety Plates and Decals .....</b>	<b>2-3</b>
<b>Operator's Compartment and Controls .....</b>	<b>2-6</b>
<b>Key/Start Switch .....</b>	<b>2-7</b>
<b>Seat Adjustment .....</b>	<b>2-7</b>
<b>Warning Indicator Lights .....</b>	<b>2-8</b>
<b>Hour Meter .....</b>	<b>2-9</b>
<b>Fuel Gauge .....</b>	<b>2-9</b>
<b>Water Temperature Gauge .....</b>	<b>2-9</b>
<b>Choke Control .....</b>	<b>2-9</b>
<b>Horn Button .....</b>	<b>2-9</b>
<b>Direction/Speed Control .....</b>	<b>2-10</b>
<b>Accelerator Pedal .....</b>	<b>2-10</b>
<b>Service Brake Pedal .....</b>	<b>2-10</b>
<b>Parking Brake .....</b>	<b>2-10</b>

---

## Tow Tractor Model Description

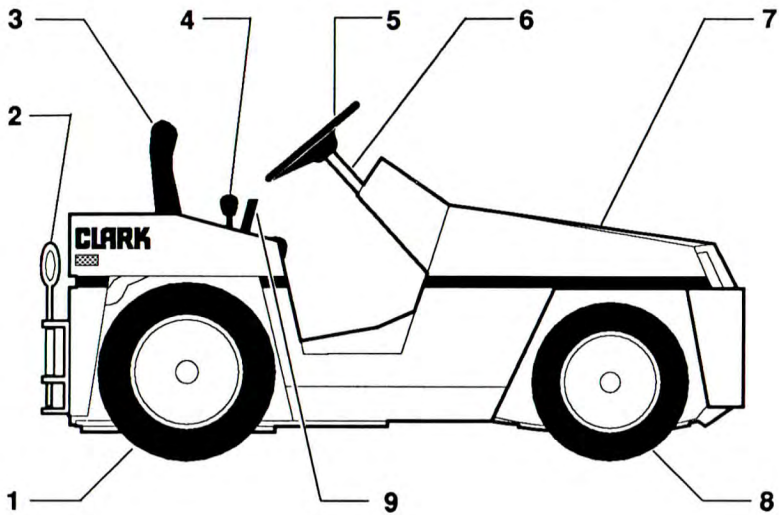

### Clark GT/DTE Series

1. Drive Axle and Wheels
2. Towing Coupler
3. Seat
4. Directional Control Lever
5. Steering Control Handwheel
6. Steer Column
7. Engine Compartment
8. Steer Axle and Wheels
9. Parking Brake

## Tractor Data and Capacity Plate

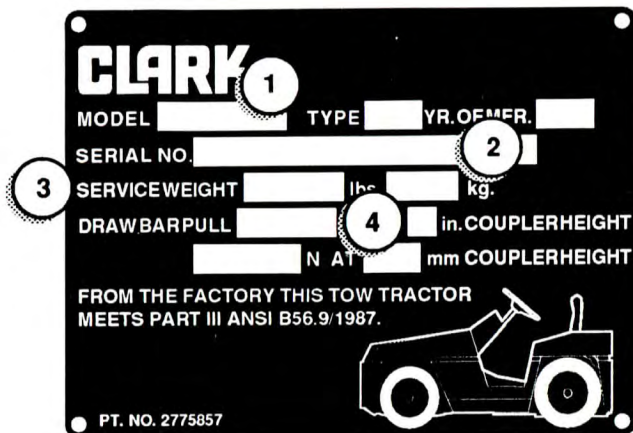

1. Tractor model number or registered name.
2. Tractor serial number—An identification number assigned to this particular tractor and should be used when requesting information or ordering service parts for this tractor from your authorized CLARK dealer. The serial number is also stamped on the frame.
3. Tractor weight—This is the approximate weight of the tow tractor. This weight plus the weight of the trailers must be considered when operating on elevators, elevated floors, etc., to be sure they are safe.
4. Capacity rating. This shows the maximum capacity with relation to drawbar pull. Personal injury and damage to the tractor can occur if these capacities are exceeded. **Do not exceed the maximum capacity specified.**

**CAUTION**

When attachments are added or if the tractor is modified, the capacity of the tractor may be affected. Contact your authorized CLARK dealer for a new nameplate showing the revised capacity.

## Operator Safety Warning Decal



# WARNING

**BREAKING THESE RULES WILL CAUSE SERIOUS OR FATAL INJURY TO YOURSELF AND OTHERS.**

- Do not operate this tow tractor unless you are trained and authorized by your employer.
- Read the attached operator's manual before starting. If you do not understand it, ask your supervisor for help. Keep the manual with the tractor.
- Look where you drive; follow your employer's speed and traffic rules. Make room for people, obstructions, and other hazards. Watch for the clearance of equipment you are towing.
- Before getting off, shift to neutral, turn off key, and set parking brake.
- Carry a passenger only when the extra seat is provided.
- Tow tractors will tip over if not properly operated. Slow down for corners, never turn on slopes, brake smoothly and avoid curbs or other obstructions. Check tire condition and pressure regularly.
- Do not operate if damaged or faulty. Do not attempt repair if you are not trained and authorized.

Clark Material Handling Co.

Tow Tractor

2775281

### IMPORTANT

Safety and warning decals are placed in conspicuous locations on the tractor to remind you of essential procedures or to prevent you from making an error that could damage the tractor or possibly cause personal injury. You should know, understand, and follow these instructions. Safety and warning decals should be replaced immediately if missing or defaced (damaged or illegible). Refer to your Service Manual for the location of all decals.



### Fan Warning Decal

This safety decal is displayed on the cooling fan shroud of the radiator to warn of the danger of injury from spinning fan blades when the engine is running. Be sure that you keep your hands, fingers, arms, and clothing away from a spinning fan. Don't stand in line with a spinning fan. Fan blades can break at excessively high RPM and be thrown out of the engine compartment.



### Seat Deck Warning Decal

This safety decal is to warn of the danger of working under the raised seat deck, which is necessarily a sturdy unit of substantial weight. The safety pins are provided to insure that if cannot fall from the raised position while an operator or mechanic is working under it. Make it a habit to insert the pins on both sides whenever you raise the seat deck.

Inspect the pins before every use for wear or damage. If their condition is doubtful in anyway; nicks, grooves, etc., they must be replaced before anyone works under the raised seat deck.

### WARNING

**BREAKING THESE RULES WILL CAUSE SERIOUS OR FATAL INJURY TO YOUR SELF AND OTHERS.**

- Do not operate in this area unless both safety pins are installed to keep the seat deck up.

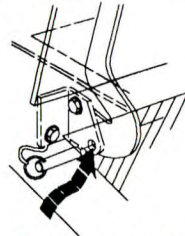

- Pins should be inserted until rings stop against hinges.

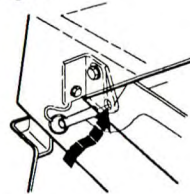

- After seat deck is lowered replace pins in storage position.

---

## Operator's Compartment & Controls

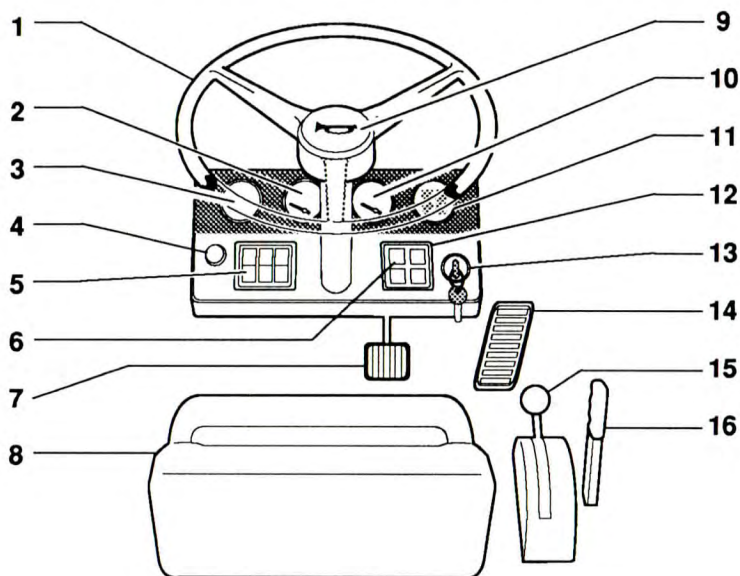

- |                             |                              |
|-----------------------------|------------------------------|
| 1. Steering Handwheel       | 9. Horn Button               |
| 2. Fuel Gauge               | 10. Water Temperature Gauge  |
| 3. Hourmeter                | 11. Warning Indicator Lights |
| 4. Choke Control (gas only) | 12. Indicator Lights         |
| 5. Switch Panel             | 13. Key Switch               |
| 6. Cold Start (diesel only) | 14. Accelerator Pedal        |
| 7. Service Brake Pedal      | 15. Transmission Lever       |
| 8. Operator Seat            | 16. Parking Brake            |

## Key/Start Switch

The Key/Start Switch:

- Turns the tractor electrical system on and off.
- Connects and tests the warning indicator lights.
- Connects the starter motor circuit when engine is to be started.

The Key/Start Switch has three positions. When the key is in the vertical "OFF" position, all tractor electrical circuits are off, and the key can be removed. From the "OFF" position, the key can be turned clockwise to the "START" position, where the starter motor is engaged and part of the tractor electrical system is energized. When the key is released from the "START" position, it automatically returns to the "RUN" position, where the starter is disengaged and the entire tractor electrical system is on.

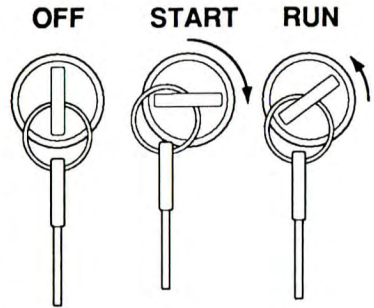

### IMPORTANT

The key switch has a mechanical "anti-restart" feature, which prevents the engine starter from being damaged if the operator attempts to start the engine when it already running. The key switch cannot be turned to the "START" position from the "RUN" position without returning the key to the "OFF" position. If the engine stops running, the key switch must be turned to the "OFF" position before it can be restarted.

## Seat Adjustment

The forward and aft adjustment lever is located on the left side under the seat. To unlock, push the lever to the left and adjust the seat so that all controls may be comfortably reached. Then release the lever. Be sure that the seat locking is engaged. The seat has a 6" fore and aft adjustment.

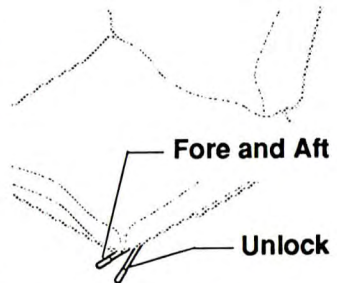

### CAUTION

Never adjust driver's seat while tractor is moving, to avoid the possibility of loss of control and of personal injury.

## Warning Indicator Lights

Warning indicator lights are provided for protection of six important systems of your tow tractor.

1. **Water Temperature:** This symbol displays when the engine is overheating for some reason.
2. **Engine Oil Pressure:** This symbol displays when the engine oil pressure reaches the minimum allowable limit.
3. **Ammeter:** This symbol displays when the alternator is not charging the battery.
4. **Transmission Oil Temperature:** This symbol displays when the transmission oil temperature reaches the maximum allowable limit.
5. **Parking Brake:** This symbol displays when the parking brake is engaged.
6. **Service Brake System:** This symbol displays when the service brakes are not functioning properly.

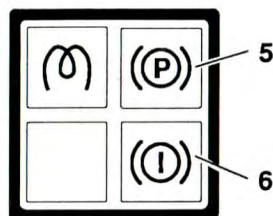

The warning lights can be tested with the key switch. Turn the key switch clockwise to the run position. The lights should illuminate, and the fuel gauge needle should indicate fuel level. The water temperature and transmission oil temperature lights are also checked when the key switch is turned to the start position.

### IMPORTANT

If you don't want to start the engine when checking these warning lights, apply the service brake, move the directional control from neutral, then turning the key switch to the start position. After checking the indicator lights, turn key switch off, and return the directional control to neutral.

**Hour Meter**

Indicates total engine operating time in hours and tenths. The indicated hours are used for planned maintenance. The total hours should be recorded at the beginning and end of each shift.

**Fuel Gauge**

Indicates quantity of fuel remaining in the tank in fractions of the whole. Fuel level should be checked at the beginning of each shift. Always start with a full tank. *(Not used on LPG)*

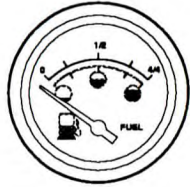
**Water Temperature Gauge**

Indicates temperature of engine coolant water in degrees. If the indicator registers in the "hot" zone, turn off the engine until the trouble is located and corrected.

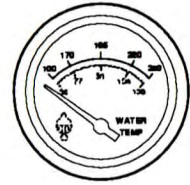
**Choke Control (Gasoline Only)**

Pull choke knob out to "close" the choke on the carburetor. Push in to "open" the choke. As the engine reaches normal operating temperature, the choke should be pushed in so that flooding of the engine does not occur.

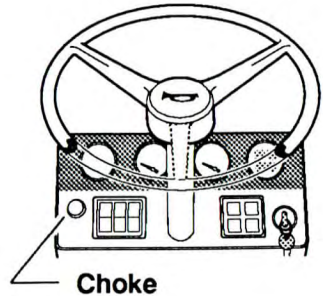
**Horn Button**

The horn button is located in the center hub of the steering handwheel.

## Direction/Speed Control

Direction and speed is controlled by the transmission shifter located on the seat deck to the operator's right.

### CAUTION

**For safety, always bring the tractor to a complete stop before shifting to the opposite direction.**

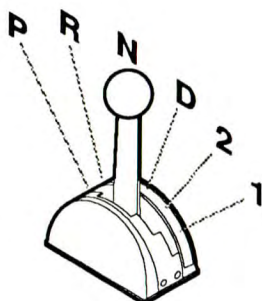

## Accelerator Pedal

The speed of the engine and tractor travel speed are controlled by the accelerator pedal suspended from the cowl.

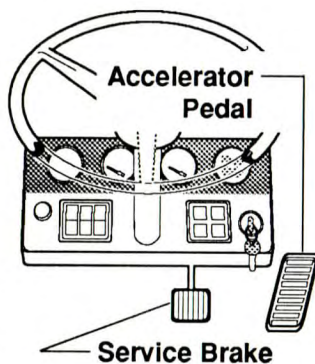

## Service Brakes

Braking of the tractor is controlled by a brake pedal suspended from the cowl. Service brakes are hydraulic assisted mechanically balanced disk brakes.

## Parking Brake

The parking brake is located on the seat deck to the operator's right. Pull the lever back to vertical position to apply the parking brake. The lever should snap-lock easily into applied position, when correctly adjusted. Push the lever forward to release the parking brake.



### IMPORTANT

**If the parking brake is not functioning properly or is out of adjustment, have a trained and authorized mechanic make repairs.**

## Operator Maintenance and Care

### Contents

Daily Safety Inspection .....	3-2
Fuel Safety Practices .....	3-4
Refuelling LPG Tanks .....	3-5

### NOTICE

The Occupational Safety and Health Act (OSHA) requires that tractor users inspect their tractors before each shift to be sure they are in safe working order. Defects when found shall be immediately reported and corrected. The tractor shall be taken out of service until it has been restored to safe operating condition.

---

## Daily Safety Inspection

Before using a tow tractor, **It is the operator's responsibility** to check its condition and be sure it is safe to operate.

Check for damage and maintenance problems; have repairs made before you operate the tractor. Unusual noises or problems must be reported immediately to your supervisor or other designated authority.

Do not make repairs yourself unless you are trained in tow tractor repair procedures and authorized by your employer. Have a qualified mechanic make repairs using genuine CLARK or CLARK-approved parts.



### CAUTION

**Do not operate a tractor if it is in need of repair. If it is in an unsafe condition, remove the key and report the condition to the proper authority. If the tractor becomes unsafe in any way while you are operating it, stop operating the tractor, report the problem immediately, and have it corrected.**

Tow tractors should be inspected every eight hours, or at the start of each shift. In general, the daily inspection should include the **visual and functional checks** described on the following pages.

As an aid in carrying out this inspection, CLARK has prepared a form called the "**Driver's Daily Checklist.**" We recommend that you use this form to make a daily record of your inspections and tractor condition. You may obtain copies of this form from your CLARK dealer.

### Visual Checks

First, perform a visual inspection of the tractor and its major components:

1. Walk around your tow tractor and take note of obvious damage that may have been caused by operation during the last shift.
2. Check that all capacity, safety, and warning plates or decals are attached and legible.
3. Check before and after starting engine for leaking fuel, engine coolant, transmission fluid, etc.
4. Be sure that all safety devices are in place, securely fastened and undamaged. Inspect for damaged or missing parts, corrosion, cracks, breaks etc.
5. Inspect the wheels and tires for safe mounting, wear condition, and air pressure.
6. Check engine oil level, and fuel level.



### Functional Checks

Check the operation of the tractor as follows.

#### NOTICE

**Before performing these checks, familiarize yourself with the starting, operating, and shutdown procedures in Section 5 of this manual. Also, know the safety rules given in Section 1 of this manual.**

1. Test warning devices, horn, lights, and other safety equipment and accessories.
2. Start the engine and be sure all controls and systems operate freely and return to neutral properly. Check the:
  - Gauges, meters, and indicator lights
  - Service brakes and parking brake
  - Accelerator
  - Directional control
  - Steering system

When the functional checks are completed, follow the **standard shutdown procedures** given in Section 5, "Starting and Operating Procedures."

### Concluding the Inspection

Make a record on the "Driver's Daily Checklist" of all the problems that you find. Review the checklist to be sure it has been completed and turn it in to the person responsible for lift tractor maintenance. Be sure any unusual noises or problems are investigated immediately.

**Do not operate a tow tractor that has a maintenance problem or is not safe to operate.**

Instead, remove the key from the ignition switch and put an "Out of Service" tag on the tractor.

If all of the Daily Inspection checks were normal or satisfactory, the tractor can be operated.

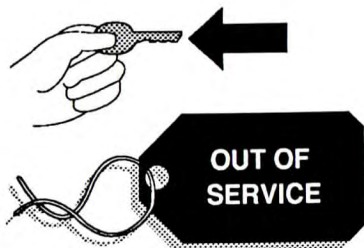

## Fuel Safety Practices

### Refueling Gasoline and Diesel Tow Tractors

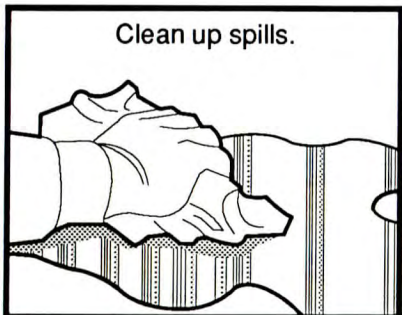
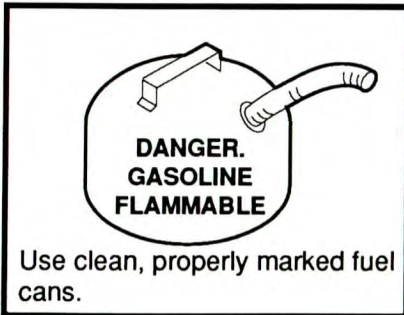
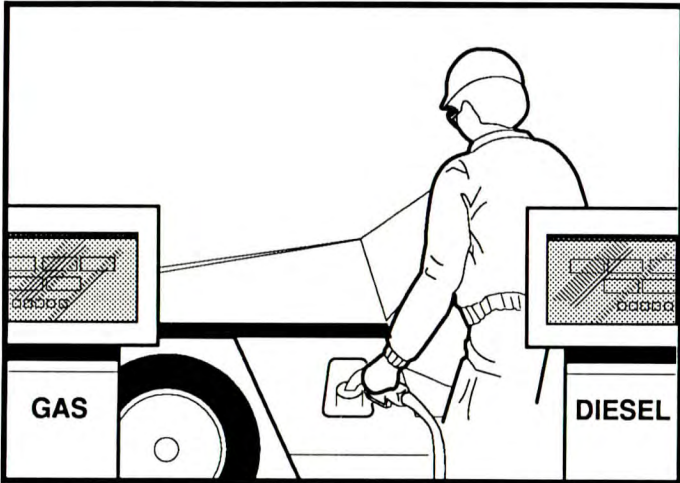

## Refueling LPG Tanks

When changing liquefied petroleum gas (LPG), tanks follow these basic rules:

- Change only in well ventilated areas.
- Never allow open flames.
- Turn the ignition switch to the OFF position.
- Check for leaks.
- Check condition of the O-ring.
- Make sure tank is on locating pin.
- Make sure tank latches are securely fastened.
- Store tanks according to local fire codes

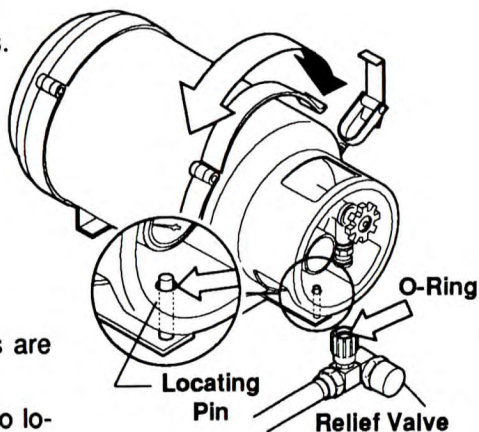

If you refill LPG tanks:

- Make sure you know and understand the proper procedure for filling an LPG tank.
- If you have any questions on refilling LPG tanks, please ask your supervisor.

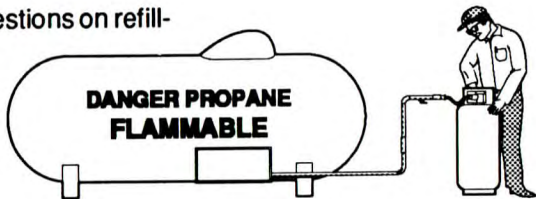

**DANGER**

**LPG IS HEAVIER THAN AIR.** It settles on your clothes and the ground around you, displacing oxygen vital for breathing. Open flame can cause flash fires.

**IMPORTANT**

**Check all connections for damage or leaks. If the tractor will not start after you change tanks, get a qualified mechanic to check the tractor.**

## RECOMMENDED SAFETY MAINTENANCE PROCEDURES FOR LPG-FUELED TOW TRACTORS



### WARNING

**LPG is a combustible fuel that is heavier than air. Escaping gas may accumulate in low areas. The fuel cylinder should be mounted so that it does not extend outside the tractor and should also be properly positioned by using the locating pin or key way.**

The fuel valve should be turned off when the machine is not in service.

Cast fittings should not be used in the LPG system.

Use only Underwriters Laboratories or Factory Mutual listed LPG hose assemblies where pressure fuel lines are required.

All pipe threaded fittings should be installed using an approved sealing compound.

Fuel lines should be supported by clamps to minimize chafing and wear.

The LPG solenoid valve should be wired to an automatic shut off switch (oil pressure or vacuum) to prevent leakage of gas in the event the ignition is on without the engine running.

Check the LPG solenoid or vacuum shutoff valve for leakage as follows:

1. Turn fuel tank valve off, start and run engine until it stops.
2. Install a 0 to 30 psi pressure gauge per instruction A or B:
  - A. To primary test port of single units consisting of primary and secondary regulators.
  - B. Between the primary and secondary stage regulators when the LPG system consists of two regulators.
3. Turn the tank fuel valve on. The pressure gauge should maintain a zero reading. If it does not, the solenoid valve or vacuum shutoff valve must be repaired or replaced. An odor is added to LPG to help indicate leaks. If you detect gas odor, you should turn off the fuel tank supply valve and engine. Remove all sources of ignition, and ventilate the area. Make all of the necessary repairs before you turn the fuel supply on. The complete LPG system should be inspected periodically. Check all hoses for wear, connections for leaks, and all parts for damage.

**NOTE:** Fuel hoses have a limited life expectancy. They should be checked for cracking and drying due to age. Hoses with visible signs of age should be replaced. Use only Underwriters Laboratories or Factory Mutual listed LPG parts for replacements.

**NOTE:** The above information is provided as a guide. Consult the National Fire Protection Association Pamphlet 58 for the safe storage and handling of liquefied petroleum gases. Governmental safety regulations in your locality could vary. Check with the authority having jurisdiction to be sure that you meet all of their requirements. Contact the manufacturer for detailed service information.

**SERVICE WORK SHOULD BE PERFORMED BY  
QUALIFIED PERSONNEL ONLY.**

## Starting and Operating Procedures

### Contents

Before Operating the Tow Tractor .....	4-2
Starting From a Safe Condition .....	4-2
General Starting and Operating .....	4-3
Starting the Engine .....	4-5
Selecting Direction of Travel .....	4-6
Accelerator .....	4-6
Braking .....	4-6
Parking Brake .....	4-6
Operating Safely .....	4-7
Shut-Down Procedure .....	4-9

---

## Before Operating the Tractor

Be sure that you have read and understand the information in this Operator's Manual and are trained and authorized before operating the tow tractor.

The Operator's Manual is stored in a compartment located on the dash. It is attached with a cable so that it can be used easily, but cannot be removed from the tractor.



### WARNING

**Inspect your tow tractor before operating at the start of the day or shift. Before putting your tractor to use, check the operation of the controls and all other systems.**

**A tow tractor can be dangerous if not used properly. Safe operation is the responsibility of the operator.**

**Do not operate the tractor, or any of its functions, from any place other than the designated operator's position.**

## Starting from a Safe Condition

Always start from a safe condition. Before operating a tow tractor, make sure that:

- You are safely seated in the operator's position.
- The parking brake is applied
- You are familiar with how all the controls function.
- Tractor is in park.
- The tractor has received its daily inspection and is ready and safe to operate.

### Seat Adjustment

The fore and aft adjustment lever is located on the left side under the seat. To unlock the, push the lever to the left and adjust the seat so that all controls may be comfortably reached. Then release the lever. Be sure that the seat locking is engaged. The seat has a 6" fore and aft adjustment.

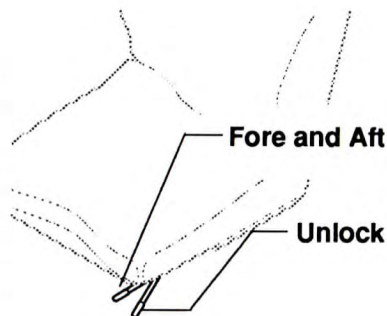



**CAUTION**

**Never adjust driver's seat while the tractor is moving, to avoid the possibility of loss of control and of personal injury.**

### **General Starting and Operating Tips**

Before you start the tractor, make sure that you have taken all the above mentioned precautions, you have read this manual, you are starting from a safe condition, with the directional control in PARK and the parking brake set, and the seat adjusted to a comfortable operating position.

Turn off any lights or optional electrical equipment while you crank the engine. Avoid excessive starter cranking (in excess of 30 seconds). To avoid starter overheating or damage, do not crank the starter continuously for more than 30 seconds at a time. If the engine fails to start, wait two to three minutes before again attempting to start the engine.

If your battery is "run down" (discharged) or becomes discharged while you try to start your tractor, please refer to, "Emergency Starting and Towing," in this manual.

To avoid damage to your tractor or possible harm to yourself . Follow these recommendations:

- Warm the engine up before driving or applying a load. Idle engine at 650-750 RPM (diesel) and 600-650 RPM (gas/LPG) for a few minutes to circulate and warm the oil. Then increase speed to approximately half throttle for a short period or until the engine coolant reaches approximately 100°F. This procedure helps prolong engine life.
- Let the engine run until the normal operating temperature is reached. Then operate the controls and check all gauges and warning indicators to be sure they are functioning properly. Stop the engine and make a visual inspection for oil, water, or fuel leaks.
- Do not operate the engine at speeds above idle for more than brief periods without a load.
- Do not run the engine at maximum power continuously until the engine is fully warmed up.
- Never operate the engine at more than the regular no-load governed speed. Excessive speeds are harmful.

### NOTICE

The governor is set at the factory and should need no adjustment.

- Avoid extended (in excess of 10 minutes) and unnecessary idling of the engine. Turn off engine instead.
- Carbon monoxide is colorless and odorless, but can be present with all exhaust fumes.



### WARNING

Exhaust gases are harmful and can cause serious injury or death proper ventilation is always necessary for safe inside operation or warm-up.

### IMPORTANT

Due to the precise tolerances of diesel injection system, it is extremely important that the diesel fuel be kept clean and free of dirt, or water. Dirt or water in the system can cause severe damage to both the injection pump and the injection nozzles.



### NOTICE

**LPG: OPEN THE TANK SHUT-OFF VALVE SLOWLY.** If it is opened too quickly, the automatic safety check valve will close and the engine will not start. If this happens, close the shut-off valve and wait two to three minutes. Then, open the shut-off valve slowly.



### WARNING

Liquid propane gas (LPG) is highly flammable. Never smoke when changing tanks. Never change tanks when engine is running.



## Starting the Engine

### Cold Start (Gasoline Only)

When starting the gasoline engine, especially when cold, you may need to set the manual choke. To do this pull the choke control out approximately half way. When the engine starts, vary the choke and throttle controls to obtain a smooth operating range.

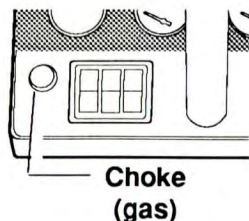

Continue as the engine warms up. By the time the engine runs smoothly under load, the choke control should be pushed all the way in (OFF).

### Cold Start Preheating (Diesel Only)

With the key switch on, press and hold the preheat switch 10 to 15 seconds then crank the engine while continuing to hold the switch. Release the switch when the engine starts.



### DANGER

**DO NOT USE STARTING FLUID to help start an engine. The fluid contains ether or other explosive substances that could cause serious injury. Starting fluid is especially dangerous when used on engines with glow plugs. Never use starting fluid with a glow plug equipped engine.**

1. Turn the key/start switch to the START position to crank the engine. Release the key to the RUN position and return the accelerator to idle as soon as the engine starts.

### IMPORTANT

**If the engine stalls or falters in starting, wait three or four seconds before reengaging the starter. This prevents possible serious damage to the starter or engine.**

2. When starting a cold engine, increase the engine speed (RPM) slowly to be sure adequate lubrication is available to the bearings and to allow the oil pressure to stabilize.
3. Idle the engine three to five minutes at 1,000 RPM before operating with a load.

## Selecting Direction of Travel

Start the tow tractor with the parking brake set and the direction control lever in the PARK or NEUTRAL position. After the tractor is running, release the parking brake then select the desired direction of travel by moving the control lever to the proper setting.

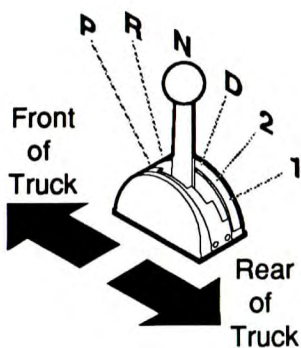

### CAUTION

Always bring the tractor to a complete stop before shifting to the opposite direction.

## Using the Accelerator

With the parking brake released and the direction control in FORWARD or REVERSE, look in the direction of travel, put your foot on the accelerator pedal and push down smoothly until the tractor is moving at the desired speed.

## Braking

To stop the tractor, lift your foot from the accelerator pedal and put it on the brake pedal. Push down on the brake pedal in a smooth, firm motion until the tractor is stopped.



### WARNING

Stop the tow tractor as gradually as practical. Hard braking and wheel sliding are dangerous and can increase the danger of jack-knifing trailers.

## Parking Brake



### CAUTION

Never leave a tow tractor unless the parking brake is set and the transmission is in neutral or park.

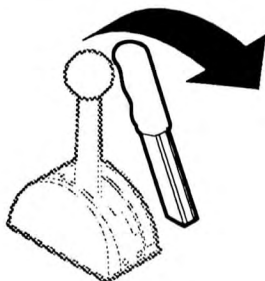

## Operating Safely

Safe operation is the responsibility of the operator.

**Watch where you are going. Don't go if you can't see...**

Before driving, check all around to be sure that your intended path of travel is clear of obstructions and pedestrians.



### WARNING

**LOOK WHERE YOU DRIVE. Watch out for pedestrians, other vehicles, obstructions, and drop-offs.**

Watch for people in your work area even if your tractor has warning lights or alarms. They may not watch for you.

Sound horn at intersections and wherever vision is obstructed. Do not drive a tractor up to anyone standing in front of an object.

**Protect yourself and those around you...**

Operate the tractor only from the designated operator's position. Stay within the confines of the tow tractor profile dimensions. Keep all body parts inside the operator's compartment and away from the danger of passing obstructions.

**No riders...**

Do not carry passengers. The operator is the only one who should be on the tractor. *Unless a passenger seat is provided.*

**Always be in full control of your tow tractor...**

Never operate a tow tractor or its attachments if you are not in the designated operator's position.

Never operate a tow tractor when your hands and feet are wet or greasy.

Always pick the smoothest travel route for your tow tractor. Avoid bumps, holes, slick spots, and loose objects or debris in your path that may cause the tractor to swerve or tip. If these conditions are unavoidable, slow down and carefully drive past them. Slow down for wet or slippery surfaces.

Avoid any sudden movement, it can cause the machine to tip-over. Start, stop, travel, steer, and brake smoothly.

---

Operate your tow tractor under all conditions at a speed that will permit it to be brought safely to a stop.

### **Grades, ramps, and inclines...**

Use special care when operating on ramps, inclines, and uneven areas. Travel slowly. Travel straight up and down. Do not turn or drive at an angle across an incline or ramp. Do not attempt to operate on grades in excess of those specified and/or recommended by the manufacturer.

### **Practice safe operation every time you use your tractor...**

Careful driving and operation is your responsibility. Be completely familiar with all the safe driving and load handling techniques in this Operator's Manual. Use common sense. Drive carefully; do not indulge in stunt driving or horseplay. Observe traffic rules. Watch for people and hazards. Slow down. Be in full control of your tow tractor at all times.

Follow the instructions in this manual to avoid damage to your tractor or the possibility of injury to yourself or others.

During your work, observe all functions of your tractor. This allows you to immediately recognize a problem or irregularity that could affect the safe operation of your tractor.

Periodically check the gauges and warning indicator lights in the instrument panel to be sure they indicate a normal condition. If an abnormal condition appears bring the machine to a safe condition and safe location, shut off the key switch immediately and report the problem.



### **CAUTION**

**Do not continue to operate a tow tractor that has a malfunction. Stop and have it fixed.**

## Shut-Down Procedure

**Always leave your tow tractor in a safe condition.** When you leave your tractor, or park it, follow these safety rules:

- Park in a safe area away from normal traffic.
- Never park on a grade.
- Never park in areas that block emergency routes or equipment, access to fire aisles, or stairways and fire equipment.

Before leaving the operator's position:

1. Bring the tractor to a complete stop.
2. Put the directional control lever in the PARK position.
3. Apply the parking brake.

In addition, when leaving the tractor unattended:

4. **If LPG-fueled:** Close the shut-off valve at the fuel tank and let the tractor run until it uses up the fuel remaining in the line.
5. Turn the key/start switch to the OFF position and remove the key.
6. Block the wheels, if the tractor must be left on an incline or you have any doubt about the tractor moving from a safe position.

### IMPORTANT

**If the tractor has been working hard, let the engine idle a few minutes before shutting it off.**



## Emergency Starting and Towing

### Contents

How to Tow a Disabled Tow Tractor ..... 5-2

How to Use Battery Jumper Cables ..... 5-3

---

## How to Move a Disabled Tow Tractor

If your tow tractor becomes disabled but it can be moved freely on its own wheels without further damage, use the following procedures to push it safely to a repair area.

### IMPORTANT

**It is important for your safety and the care of your tow tractor to use the proper equipment and carefully follow these recommendations.**

Push or tow for short distances only. Towing at higher speeds or longer distances can destroy the transmission. If the engine is not running the transmission receives no forced lubrication to any of its bearings.

The best method to move a tow tractor is to raise the rear tires off the ground and tow backwards or load it entirely onto another vehicle.



### WARNING

**DO NOT tow a tow tractor if there is a problem with the brakes or tires or the steering cannot be operated. DO NOT tow up or down ramps and steep inclines. DO NOT attempt to move a tow tractor if traction or weather conditions are poor.**

1. Be sure to apply the parking brake or block the drive wheels on the disabled vehicle while working around it.
2. Obtain another vehicle of equal or larger size.
3. Release the parking brake on the disabled vehicle.
4. Transmission control is in neutral.
5. Remove blocks from wheels.
6. Push on rear bumper. Push the tow tractor slowly. Careful pushing is necessary to prevent injury to personnel or damage to the tow tractor. The tow tractor should be moved at a speed of less than 2 mph (3 kph) with a driver in the seat.

### IMPORTANT

**An operator must be on the disabled tow tractor.**

7. Park the disabled tow tractor in authorized areas only, put the directional control lever in the PARK position and turn the ignition switch to the OFF position. Engage the parking brake. Remove the ignition key and, when necessary, block the wheels to prevent the tow tractor from rolling.



### WARNING

**Always engage the parking brake when parking a tow tractor. The tow tractor can move and cause injury or death to personnel near it.**



## How to Use Battery Jumper Cables



### WARNING

**BATTERIES EMIT EXPLOSIVE GAS.** Do not smoke or have open flames or sparks in battery charging areas or near batteries. An explosion can result and cause injury or death.

Hydrogen gas is produced during normal battery operation. Hydrogen can explode if flames, sparks, or lighted tobacco are brought near the battery. When charging or using a battery in an enclosed space, always provide ventilation and shield your eyes. Wear safety glasses when working around batteries.

If your tow tractor battery is discharged ("dead"), you can start your tow tractor by "jumping" it from another vehicle that has a 12-volt, negative-ground electrical system. The "booster" battery must be fully charged and in good condition. This section explains how to perform this procedure safely. To avoid damage to your tow tractor and your battery or the possibility of harm to yourself, follow the instructions and warnings carefully. If you have any doubts, ask for help from an experienced mechanic.

If your tow tractor has a battery with terminals on the side you will need a set of jumper cables with matching connector clamps or cable adapters for side-mounted battery terminals.



### CAUTION

**USE ONLY A 12-VOLT, NEGATIVE GROUND SYSTEM** to jump your tow tractor. You can injure yourself and permanently damage your tow tractor's 12-volt starting motor and ignition system by connecting it to a 24-volt power supply (two 12-volt batteries in series or a 24-volt generating set) or to a positive-ground system.



## WARNING

**BATTERIES CONTAIN SULFURIC ACID. Avoid acid contact with skin, eyes, or clothing. If acid contacts your eyes or skin, flush immediately with water and get medical assistance. Wear safety glasses when working near the battery to protect against possible splashing of the acid solution.**

1. If the discharged battery has filler caps, check the fluid level. Do not use an open flame to check and do not smoke. If low, add distilled water to the correct level. Be sure to install the caps before jump starting.
2. Do not jump start, charge, or test a sealed-type battery if the test indicator looks illuminated or has a bright color. Install a new battery.
3. Put the tow tractor with the booster battery as near to the other tow tractor as necessary for the jumper cables to reach both batteries. Check and make sure that the tow tractors do not touch each other. **Use particular care when connecting a booster battery to prevent sparks.**
4. On both tow tractors:
  - a. Apply the parking brake.
  - b. Put the directional control in the PARK position.
  - c. Turn the key/start switch to the OFF position.
  - d. Turn all accessories to the OFF position and leave them off until after the engine has been started and the jumper cables have been removed.



## WARNING

**To avoid SHORT CIRCUITS, remove all jewelry and do not permit any metal tools to make contact between the positive battery terminal and other metal on the tow tractor. When you connect jumper cable clamps to the positive terminals of the two batteries, make sure that neither clamp contacts any other metal. Injury can occur from electrical shock or explosion.**

5. Connect the jumper cables in the following sequence:

- a. Connect a jumper cable from the positive (+; red) terminal on one battery to the positive (+; red) terminal on the other battery. Never connect positive (+; red) to negative (-; black), or negative to positive.
- b. Connect one end of the second cable to the grounded negative (-; black) terminal of the "Jumper Vehicle" battery.
- c. Connect the other end of the second cable to a stationary, solid metallic point **on the engine** of the "Stalled Vehicle," **not to the negative (+; black) terminal** of its battery. Make this connection at a point at least 18 inches (450 mm) away from the battery, if possible. Do not connect it to pulleys, fans or other parts that move. Do not touch hot manifolds that can cause severe burns.

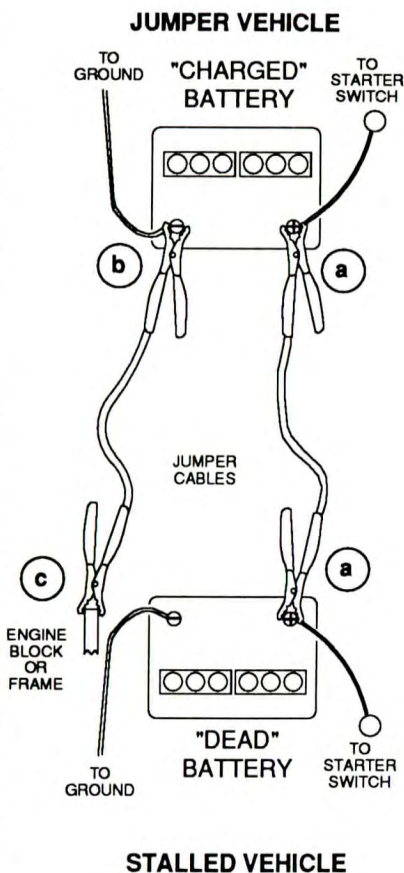

6. Start the engine on the "Jumper Vehicle" and run the engine at a moderate speed for a minimum of five minutes.
7. Start the engine on the "Stalled Vehicle." Follow the starting instructions in Section 4, "Starting and Operating Procedures" in this manual. Be sure that the engine is at idle speed before disconnecting the jumper cables.
8. Remove the jumper cables by reversing the installation sequence exactly. Start by removing the last jumper cable from the stalled vehicle first. Remove the cable end from the engine block first, then the other end of the negative (-; black) cable.
9. Remove both ends of the positive (+; red) cable.



## Planned Maintenance and Lubrication

### Contents

<b>Introduction</b> .....	<b>6-2</b>
<b>Safe Maintenance Practices</b> .....	<b>6-3</b>
<b>Planned Maintenance Intervals</b> .....	<b>6-7</b>
<b>PM Report Form</b> .....	<b>6-9</b>
<b>How to Perform Planned Maintenance</b> .....	<b>6-10</b>
Visual Inspection .....	6-10
Functional Tests .....	6-11
Fluids, Filters, and Engine Accessories .....	6-14
Lubrication .....	6-17
Air Cleaning .....	6-17
Critical Fastener Torque Checks .....	6-18

#### NOTICE

**THIS SECTION IS FOR TRAINED SERVICE PERSONNEL to use as a reference for Planned Maintenance procedures. Complete maintenance information is in Service Manual SM606.**

**Maintenance Information for operators is in Section 3, "Operator Maintenance and Care."**

---

## Introduction

### NOTICE

**ONLY TRAINED AND AUTHORIZED PERSONNEL should perform Planned Maintenance. Local CLARK dealers are prepared to help customers put in place a Planned Maintenance program for checking and maintaining their tow tractor according to applicable safety regulations.**



### CAUTION

**Powered Industrial tow tractors may become hazardous if maintenance is neglected.**

As outlined in Section 3, "Operator Maintenance and Care," the operator should make a safety inspection of the tow tractor before operating it. The purpose of this daily examination is to check for any obvious damage and maintenance problems, and to have minor adjustments and repairs made to correct any unsafe condition.

**In addition to the operator's daily inspection**, CLARK recommends that the owner set up and follow a periodic planned maintenance (PM) and inspection program. Performed on a regular basis **by trained personnel**, the program provides thorough inspections and checks of the safe operating condition of the tow tractor. "The PM" identifies needed adjustments, repairs, or replacements so they can be made before failure occurs. The specific schedule (frequency) for the PM inspections depends on the particular application and tow tractor usage.

This Section recommends typical Planned Maintenance and Lubrication Schedules for items essential to the safety, life, and performance of the tow tractor. It also outlines safe maintenance practices and gives brief procedures for inspections, operational checks, cleaning, lubrication, and minor adjustments.

Specifications for selected components, fuel, lubricants, critical bolt torques, refill capacities, and settings for the tow tractor are found in Section 7.

If you have need for more information on the care and repair of your tow tractor, see you CLARK dealer.

## **Safe Maintenance Practices**

The following instructions have been prepared from current industry and government safety standards applicable to industrial tow tractor operation and maintenance. These recommended procedures specify conditions, methods, and accepted practices that aid in the safe maintenance of industrial tow tractors. They are listed here for the reference and safety of all workers during maintenance operations. Carefully read and understand these instructions and the specific maintenance procedures before attempting to do any repair work. When in doubt of any maintenance procedure, please contact your local CLARK dealer.

1. Powered industrial tow tractors can become hazardous if maintenance is neglected. Therefore, suitable maintenance facilities and trained personnel and procedures shall be provided.
2. Maintenance and inspection of all powered industrial tow tractors shall be performed in conformance with the manufacturer's recommendations.
3. Follow a scheduled planned maintenance, lubrication, and inspection system.
4. Only trained and authorized personnel are permitted to maintain, repair, adjust, and inspect industrial tow tractors—and must do so in accordance with the manufacturer's specifications.
5. Always wear safety glasses. Wear a safety (hard) hat in industrial plants and in special work areas where protection is necessary and required.
6. Properly ventilate work area, vent exhaust fumes, and keep shop clean and floors dry.
7. Avoid fire hazards and have fire protection equipment present in the work area. Do not use an open flame to check for level or leakage fuel, electrolyte, or coolant. Do not use open pans of fuel or flammable cleaning fluids for cleaning parts.
8. Before starting work on tow tractor:
  - a. Raise drive wheels free of floor and use oak blocks or other positive tow tractor positioning devices.
  - b. Remove all jewelry (watches, rings, bracelets, etc.).
  - c. Disconnect the battery ground cable ( - ) before working on the electrical system.

---

## NOTICE

**Refer to the "Jacking and Blocking" section in the Service Manual for proper procedures.**

9. Operation of the tow tractor to check performance must be conducted in an authorized, safe, clear area.
10. Before starting to operate the tow tractor:
  - a. Be seated in the operator's position.
  - b. Make sure parking brake is applied.
  - c. Put the direction control in PARK or NEUTRAL.
  - d. Start the engine.
  - e. Check direction and speed controls, steering, brakes and warning devices.
11. Before leaving the tow tractor:
  - a. Stop the tow tractor.
  - b. Put the directional control in NEUTRAL.
  - c. Apply the parking brake.
  - d. Stop the engine.
  - e. Turn the key switch to the OFF position.
  - f. Put blocks at the wheels if the tow tractor must be left on an incline.
12. Brakes, steering mechanisms, control mechanisms, warning devices, lights, governors, and frame members must be carefully and regularly inspected and maintained in a safe operating condition.
13. Special tow tractors or devices designed and approved for hazardous-area operation must receive special attention to insure that maintenance preserves the original approved safe operating features.
14. Fuel systems must be checked for leaks and condition of parts. Extra special consideration must be given in the case of a leak in the fuel system. Action must be taken to prevent the use of the tow tractor until the leak has been corrected.
15. The tow tractor manufacturer's capacity, operation, and maintenance instruction plates, tags, or decals must be maintained in legible condition.
16. Batteries, limit switches, protective devices, electrical conductors, and connections must be maintained in conformance with good



practice. Special attention must be paid to the condition of electrical insulation.

17. To avoid injury to personnel or damage to the equipment, consult the manufacturer's procedures in replacing contacts on any battery connection.
18. Industrial tow tractors must be kept in a clean condition to minimize fire hazards and help in detection of loose or defective parts.
19. Modifications and additions that affect capacity and safe tow tractor operation shall not be done without the manufacturer's prior written approval. Capacity, operation, and maintenance instruction plates, tags, or decals must be changed accordingly.
20. Care must be taken to assure that all replacement parts, including tires, are interchangeable with the original parts and of a quality at least equal to that provided in the original equipment. Parts, including tires, are to be installed per the manufacturer's procedures. Always use genuine CLARK or CLARK-approved parts.
21. When removing tires follow industry safety practices. Most importantly, deflate pneumatic tires completely prior to removal.
22. Use special care when removing heavy components, such as counterweight, etc. Be sure that lifting and handling equipment is of the correct capacity and in good condition.

### **IMPORTANT**

**Your new CLARK tow tractor has been built to meet all applicable mandatory requirements of ANSI B56.9-1992 Operator Controlled Industrial Tow Tractors. (Safety Code For Powered Industrial Tow tractor). Each tow tractor also includes certain safety devices, e.g. horn and lights as standard equipment.**

**No additions, omissions or modifications shall be made that will affect compliance to the above requirements or in any way minimize the effectiveness of the safety devices.**

---

## NOTICE

**You should be familiar with additional operating and maintenance safety instructions contained in the following publications:**

*ANSI/ASME B56.9 - 1992: Operator Controlled Industrial Tow Tractors (Safety Code For Powered Industrial Tow tractors).* Published by: American Society of Mechanical Engineers, United Engineering Center, 345 E. 47th Street, New York, NY 10017.

*NFPA 505-1982: Fire Safety Standard for Powered Industrial Tow tractors: Type Designations, Areas of Use, Maintenance and Operation.* Available from National Fire Protection Association, Inc., Batterymarch Park, Quincy, MA 02269.

*General Industrial Standards, OSHA 2206: OSHA Safety and Health Standards (929 CFR 1910), Subpart N-Materials Handling and Storage, Section 1910.178 Powered Industrial Tow tractors.* For sale by: Superintendent of Documents, US Government Printing Office, Washington, DC 20402.

## Planned Maintenance Intervals

Time intervals between maintenances are largely determined by operating conditions. For example, operation in sandy, dusty locations requires shorter maintenance intervals than operation in clean warehouses. The indicated intervals are intended for **normal** operation. The operating condition classifications are:

### Normal Operation

Eight-hour baggage handling, mostly in buildings or in clean, open air on clean paved surfaces.

### Severe Operation

Prolonged operating hours or constant usage.

### Extreme Operation

- In sandy or dusty locations, such as cement plants, lumber mills, and coal dust or stone crushing sites.
- High-temperature locations, such as steel mills and foundries.
- Sudden temperature changes, such as constant trips from buildings into the open air, or in refrigeration plants.

If the tow tractor is used in severe or extreme operating conditions, you must shorten the maintenance intervals accordingly.

### NOTICE

**Since the operating environment varies widely, the above descriptions are highly generalized and should be applied as actual conditions dictate.**

The maintenance time intervals referred to in this manual relate to tow tractor operating hours as recorded on the hour meter, and are based on experience CLARK has found to be convenient and suitable under typical (normal or average) operating conditions. The periods and their designations are:

**PM Interval:**

- A = 8 - 10 hours or daily
- B = 50 - 250 hours or every month (typical PM interval)
- C = 450 - 500 hours or every 3 months
- D = 900 - 1000 hours or every 6 months
- E = 2000 hours or every year

<b>DAILY MAINTENANCE CHECKS</b>	<b>A</b>	<b>B</b>	<b>C</b>	<b>D</b>	<b>E</b>
Check truck for obvious damage and leaks.	•				
Check fuel system for leaks, etc.	•				
Check capacity, warning plates, decals.	•				
Check condition of tires and wheels, remove embedded objects.	•				
Check wheel lugs nuts.	•				
Check engine oil level.	•				
Check engine coolant level.	•				
Check fuel level.	•				
Check gauges and instruments.	•				
Check warning lights and hour meter.	•				
Check horn operation and other warning devices.	•				
Check steering operation.	•				
Check service brake operation.	•				
Check parking brake operation.	•				
Check directional and speed controls operation.	•				
Check accelerator and engine speed operation.	•				

<b>PERIODIC CHECKS and PLANNED MAINTENANCE (PM)</b>	<b>A</b>	<b>B</b>	<b>C</b>	<b>D</b>	<b>E</b>
Check truck visually and inspect components.		•			
Test drive truck--Check functional performance.		•			
Air clean truck and radiator.		•			
Check critical torque fasteners.		•			
Lubricate truck (see component)		•			
Drain and replace engine oil [*]		•			
Replace engine oil filter.		•			
Clean/replace engine air filter. [**]			•		
Inspect/adjust fan belts			•		
Drain/flush radiator coolant.					•
Check engine ignition and timing.			•		
Perform engine tune-up.					•
Check battery.			•		
Check transmission fluid level.		•			
Drain and replace transmission fluid.				•	
Replace transmission oil filter.				•	
Clean drive axle air vent.		•			
Check brake condition and wear.					•
Check drive axle mounting and fasteners.		•			
Lubricate steer axle linkage.		•			
Check/lubricate steer axle wheel bearings.					•

## NOTES:

- Oil change intervals may be determined by laboratory analysis.
- Air filter change interval may be determined by using the air restriction indicator.

### PM Report Form

Make and keep records of your PM inspections. Use these records to help establish the correct PM intervals for the tow tractor application and to indicate maintenance required to prevent major problems from occurring during operation.

As an aid in performing and documenting your PM inspections, CLARK has prepared a **Gas, LPG, or Diesel Planned Maintenance Report Form**. Copies of this form may be obtained from your authorized CLARK dealer. We recommend that you use this form as a checklist and record of your inspection and tow tractor condition.

---

The maintenance procedures outlined in this Section are intended to be used in conjunction with the PM Report Form. They are arranged in a logical and efficient sequence.

You make a check mark or entry on the PM Report Form when the PM is performed. A special coding system for indicating the importance of needed repairs and/or adjustments appears on the form.

When you have finished the PM inspections, be sure to give a copy of the report to the designated authority or person responsible for tow tractor maintenance.

Do not make repairs or adjustments unless authorized to do so.



### CAUTION

For safety, it is good practice to:

- **Remove all jewelry (watch, rings, bracelets, etc.) before working on the tow tractor.**
- **Disconnect the battery ground cable ( - ) from the battery before working on electrical components.**
- **Always wear safety glasses. Wear a safety (hard) hat in industrial plants and in special work areas where protection is necessary and required.**

## How to Perform Planned Maintenance

### Visual Inspection

First, perform a visual inspection of the tow tractor and its components. Walk around the tow tractor and take note of any obvious damage or maintenance problems.

Check to be sure all capacity, safety, and warning plates are attached and legible.

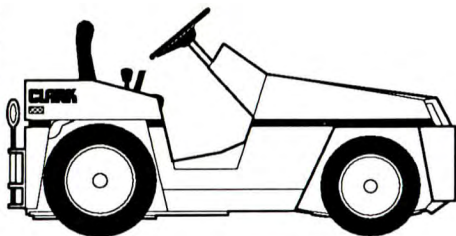

Check the tow tractor, before and after starting engine, for any signs of external leakage: fuel, coolant, transmission fluid, etc.

### NOTICE

**NAMEPLATES AND DECALS:** Do not operate a tow tractor with damaged or lost decals and nameplates. Replace them immediately. They contain important information.

### Wheels and Tires

Check the condition of the drive and steer wheels and tires. Remove objects that are embedded in the tread. Inspect the tires for excessive wear and breaks or "chunking out."

Check all wheel lug nuts or bolts to be sure none are loose or missing. Replace missing bolts or lug nuts. Torque loose or replaced items to specifications.

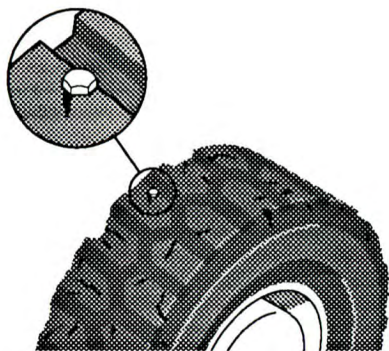

### WARNING

**Check tire pressure from a position facing the tread of the tire, not from the side. Use a long-handled gauge to keep your body away from the side. If tires are low, do not operate tow tractor and do not add air. Check with a mechanic. The tire may require removal and repair. Do not operate tow tractor with low tire pressure.**

### Functional Tests

You will start the engine to complete the functional tests, so be sure that:

- The parking brake is applied.
- Directional control is in PARK or NEUTRAL.
- You are familiar with the safety procedures given in Section 4, "Starting and Operating Procedures," in this manual.

As you test the following components, be sure they are properly mounted and working correctly.

---

## Horn

Press the horn button to check horn function. If the horn or any other part does not operate, report the failure and have it repaired before the tow tractor is put into operation.

## Neutral Start Switch

Check the operation of the neutral start switch by placing the direction control lever in FORWARD or REVERSE and turning the key switch to START position. The starter must not engage until the direction control lever is moved to the PARK or NEUTRAL position.

## Hour Meter

Start the engine and let it warm up until it runs evenly and accelerates smoothly when you push on the accelerator pedal. Check the hour meter for operation with the engine running. **Write the hour meter reading on the PM report form.** Report any malfunction or damage.

## Indicator Lights

Check that all lights are functioning and indicate normal tow tractor operation as described in Section 2, "Know Your Tow Tractor," in this manual.

## Service Brakes

With the direction control in NEUTRAL and the engine running, push the service brake pedal fully down and hold. The brakes should apply before the pedal reaches the floorplate. If the pedal continues to creep downward, report the failure immediately. **Do not operate the tow tractor until the brakes are repaired.**

## Parking Brake

Check the function of the parking brake. Release, then reapply. To check parking brake holding capability, park the tow tractor on a grade and apply the parking brake. The parking brake should hold a tow tractor with rated load on a 15% grade.



## CAUTION

**Do not operate a tow tractor if the service or parking brakes are not operating properly.**



## Steering System

### NOTICE

**The steering system, steer axle, and steering linkage on your tow tractor should be inspected periodically for abnormal looseness and damage, leaking seals, etc. Also, be alert for any changes in steering action. Hard steering, excessive freeplay (looseness), or unusual sound when turning or maneuvering indicates a need for inspection or servicing.**

Check the steering system by moving the steering handwheel in a full right turn and then in a full left turn. Return the handwheel to the straight-ahead position. The steering system components should operate smoothly when the handwheel is turned. **Never operate a tow tractor that has a steering system fault.**

### Direction Control, Braking

Be sure that the travel area is clear in front of the tow tractor.

1. Push firmly on the brake pedal. Release the parking brake. Move the directional control lever from PARK or NEUTRAL to DRIVE (forward).
2. Remove your right foot from the service brake pedal and put it on the accelerator pedal. Push down until the tow tractor moves slowly forward. Remove your foot from the accelerator pedal and push down on the service brake pedal to stop the tow tractor. The brakes should apply smoothly and equally.

Be sure the travel area is clear behind the tow tractor.

3. Put the directional control lever in the REVERSE travel position. Release the service brake and push down on the accelerator pedal until the tow tractor moves slowly in the reverse direction. Remove your foot from the accelerator pedal and push down on the service brake pedal to stop the tow tractor. The brakes should apply smoothly and equally.

Report any problems.

**When you have completed the operational tests, park and leave the tow tractor according to standard shut down procedure as described in Section 4 of this manual. Be sure to make a record of all maintenance and operating problems you find.**

---

## Fluids, Filters, and Engine Accessories

To check fluid levels and other components within the engine compartment, unlatch and open the hood to access the engine compartment.



### CAUTION

**To avoid the possibility of personal injury, never work in the engine compartment with the engine running, except when it is absolutely necessary to check or make adjustments. Take extreme care to keep hands, tools, loose clothing, etc., away from fan and drive belts. Also remove watches, bracelets, and rings.**

## Engine Accessories

Inspect the engine coolant hoses and fan belt(s). Look for leaking and obvious damage, worn (frayed) condition, breaks, etc. that could cause failure during operation.

## Engine Air Cleaner

Check the engine air cleaner for damage and contamination (excessive dirt buildup and clogging). Be sure that the air cleaner hose is securely connected (not loose or leaking). Fan or cone shaped dust deposits on tube or hose surfaces indicate a leak.

Change or service the air cleaner element every 2000 operating hours, depending upon your application. Service intervals may also be determined by the air restriction indicator.

## Battery

Inspect the battery for damage, cracks, leaking condition, etc. If the terminals are corroded, clean and protect them with CLARK Battery Saver (available from your CLARK dealer). If your battery has removable cell caps, check to be sure the cells are all filled. Refill them with distilled water.



### WARNING

**EXPLOSIVE GASES: Do not smoke or have open flames or sparks near batteries. An explosion can cause injury or death.**

### Engine Cooling System

To check engine coolant level open the hood to the engine compartment. Visually inspect the recovery bottle, locate the "HOT" and "COLD" marks. The "HOT" mark indicates maximum level at operating temperature. The "COLD" mark indicates additional coolant needs to be added to the system.

#### **IMPORTANT**

**A level anywhere between the HOT and COLD marks is normal.**

#### **IMPORTANT**

**Inspect the coolant level in the overflow bottle only.**



#### **WARNING**

**Do not remove the radiator cap when the radiator is hot. STEAM from the radiator will cause severe burns. Do not remove the radiator cap to check the coolant level.**



#### **WARNING**

**Never remove the radiator cap while the engine is running. Stop the engine and wait until it has cooled. Failure to do so could result in serious personal injury from hot coolant or steam blowout and/or damage to the cooling system or engine.**

If the level is low, add a 50/50 mixture of specified coolant and water to the correct fill level. If you have to add coolant more than once a month or if you have to add more than one quart at a time, check the coolant system for leaks.

- Check engine oil for presence of coolant leaking into engine oil system.
- Inspect the coolant for condition. Look for excessive contamination or rust or oil in the coolant solution.
- Check the PM time interval for need to change coolant.
- Check the condition of radiator cap rubber seal and radiator filler neck for damage. Be sure they are clean.
- Check overflow hose for clogging or damage.

---

## Engine Oil and Filter

Locate the engine oil dipstick. Pull the dipstick out, wipe it with a clean wiper, and reinsert it fully into the dipstick tube. Remove the dipstick and check oil level.

It is normal to add some oil between oil changes. Keep the oil level above the ADD mark on the dipstick by adding oil as required. **Do not overfill.** Use the correct oil as specified under Lubricant Specifications.

It is recommended to:

- Drain and replace the engine crankcase oil every 50 to 250 operating hours. (depending on application). *See NOTICE*
- Replace the gas engine oil filter every 500 hrs., diesel engine every 250 hrs.
- Remove the oil pan drain plug to drain old oil after the tow tractor has been in operation and the engine (oil) is at operating temperature.



### WARNING

**Engine oil at operating temperature is hot and can cause burns. Beware of splashing oil.**

- Carefully check for leaks after changing oil and installing new filter.

### NOTICE

**The time interval for changing engine oil depends upon your application and operating conditions. To determine the correct schedule for your tow tractor, it is suggested that you periodically submit engine oil samples to a commercial laboratory for analysis of the condition of the oil.**

**OIL PERFORMANCE DESIGNATION:** To help achieve proper engine performance and durability, use only engine lubricating oils of the proper quality. For gas and diesel engines, CLARK recommends that you use motor oil that meets API Service Classification CD, CC/SG, SF and API CF-4 SAE 15W-40, gas engines can also use API SD SAE 10W-30 oil or better.

## **Lubrication**

### **Tow Tractor Chassis Inspection and Lubrication**

Lubrication and inspection of tow tractor chassis components, including steer wheels, steer axle linkage, steering cylinder, and wheel bearings are easier if the tow tractor is raised and blocked up under the frame. Refer to your Service Manual for additional information on machine blocking and jacking. Also refer to your Service Manual for the location of grease fittings.

Inspect the steering cylinder piston rods, seals, and fasteners for damage, leaks, and looseness. Lubricate the steer axle linkage pivot points. Be sure to clean the grease fittings before lubricating, and remove the excess grease from all points after lubricating. Lubricate miscellaneous linkage as needed.

### **Air Cleaning**

Always maintain a tow tractor in a clean condition. Do not allow dirt, dust, lint, or other contaminants to accumulate on the tow tractor. Keep the tow tractor free from leaking oil and grease. Wipe up all oil spills. Keep the controls and floorboards clean, dry, and safe. A clean tow tractor makes it easier to see leakage and loose, missing, or damaged parts, and helps prevent fires. A clean tow tractor runs cooler. The environment in which a tow tractor operates determines how often and to what extent cleaning is necessary.

For example, tow tractors operating in manufacturing plants that have a high level of dirt, dust, or lint (for example, cotton fibers or paper dust) in the air or on the floor or ground, require more frequent cleaning. The radiator especially may require daily air cleaning to ensure correct cooling. If air pressure does not remove heavy deposits of grease, oil, etc., it may be necessary to use steam or liquid spray cleaner.

Use an air hose with special adapter or extension, a control valve, and a nozzle to direct the air properly. Use clean, dry, low pressure, compressed air. Restrict air pressure to 30 psi (207 kPa), maximum. (OSHA requirement.)



### **CAUTION**

**Wear suitable eye protection and protective clothing when air cleaning. Never point the air nozzle at anyone.**

---

### **Critical Fastener Torque Checks**

Fasteners in highly loaded (critical) components can quickly fail if they become loosened. Also, loose fasteners can cause damage or failure of the component. For safety, it is important that the correct torque be maintained on all critical fasteners of components that directly support, handle, or control the load and protect the operator.

Critical items include:

- Drive axle mounting
- Drive and steer wheel mounting
- Counterweight mountings
- Towing coupler bolts

Torque specifications are in your Service Manual.

## Specifications

Clark products and specifications are subject to improvements and changes without notice or obligation

### Model Designation — Rated Load Capacity

GT 30E - 3,000 lbs [1,360 kg]	DT 30E - 3,000 lbs [1,360 kg]
GT 50E - 5,000 lbs [2,268 kg]	DT 50E - 5,000 lbs [2,268 kg]
GT 60E - 6,000 lbs [2,722 kg]	DT 60E - 6,000 lbs [2,722 kg]

Engine	<i>Diesel</i>	<i>Gas</i>	<i>LPG/CNG</i>
Model Ford:		CGS649	CGS649
Model Perkins:	1004.4		
Cylinders:	4	6	6
Displacement			
<i>cubic inches:</i>	243	300	300
<i>liters:</i>	4.0	4.9	4.9
Idle RPM:	800-850	500-550	500-550
Governed RPM			
<i>No load @ high idle:</i>	2375±50	2100-2300	2100-2300
<i>Full load:</i>	1600-1800	1600-1800	1600-1800

### Cooling System

Automotive type crossflow radiator.

Cooling system pressure (radiator cap): 7psi

Thermostat: Diesel, 77°C (185°F), fully open 98°C (212°F),

Gas/LPG 71°C (160°F)

### Powershift Transmission

Ford Model C-6 Transaxle

Speeds: 3 forward /1 reverse

Overall Ratios: FWD/2.46:1,1.46:1,1:1                      REV/2.18:1

Converter Stall Ratio: 1.9

### Wheels and Tires

<i>Position</i>	<i>Tire/Wheel</i>	<i>Tire Pressure</i>		
		<i>GTDT30E</i>	<i>GTDT50E</i>	<i>GTDT60E</i>
Drive	7.00R15	35 psi	60 psi	N/A
Heavy Drive	7.00-15NHS	30 psi	50 psi	65 psi
Steer	185/70R14	30 psi	30 psi	30 psi

---

## Standard Electrical System

Type: 12 volt DC, negative ground

Fuses (diesel): 4, 15 amps Fuses (gas/lpg): 3, 15 amps- 1, 10amps

**Batteries:** BCI Group 31 Gas, LPG, CNG, Diesel  
Cold cranking current 12 volt DC-625 amps  
@ 0°F total

## Filters

Engine air: Dry type—replaceable element  
Engine oil: Spin-on

*Use genuine CLARK parts. See your CLARK dealer.*

## Truck Weights (approximate)

	<i>Empty Vehicle Weight (lbs)</i>	<i>Drive Axle (lbs)</i>	<i>Steer Axle (lbs)</i>
GTDT30E	5300	3450	1850
GTDT50E	6700	4550	2150
GTDT60E	7600	5730	1870

## Fuel Recommendations

Diesel: D-2 with cetane rating of 45 or higher. D-1 and Jet A-1 also acceptable.

Gasoline: 87 octane minimum

LPG: HD-5 propane

## Fill Capacities (fluid volumes)

Fuel tank:	16 US gallons;	60.5 liters
Cooling system:	6.3 quarts;	6 liters
Engine oil, w/filter (diesel):	7.5 quarts;	7.1 liters
Engine oil, w/filter (gas):	7.0 quarts	6.6 liters

## Engine Coolant Recommendation

Use a mixture of 50% ethylene glycol permanent-type antifreeze containing rust and corrosion inhibitors only. **Note:** This mixture provides antifreeze protection level of -37°C (-34°F), approximately.

## Transmission Fluid Recommendation

Use Dexron II Transmission Fluid.

## Hydraulic Fluid Recommendation

Use CLARK Specification MS-68 Hydraulic Oil, with anti-wear additives, Dexron II



## Engine Oil

Use these SAE viscosity grades.

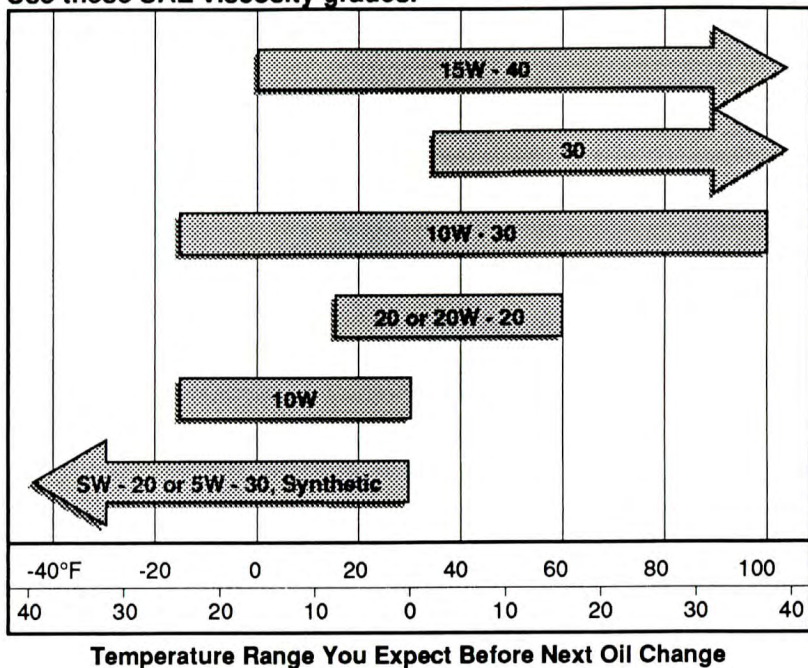

### Engine Oil Recommendations

American Petroleum Institute (API) classifications CD, CC/SG, SF and API CF-4 SAE 15W-40, gas engines can also use API SD SAE 10W-30 oil or better.

#### IMPORTANT

**Do not extend oil change intervals from those specified when using synthetic lubricants.**

Fill crankcase with correct amount of oil. When adding oil between oil changes, it is preferable to use the same brand as various oils may be incompatible. Refer to the Maintenance and Lubrication Section for recommended oil change intervals.

#### IMPORTANT

**Do not overfill crankcase. Excess oil causes foaming and can cause loss of lubrication and higher operating temperatures, resulting in engine damage.**



## Index

- A**  
 Accelerator operation ..... 2-10, 4-6  
 Air cleaning the tow tractor ..... 6-17  
 Ampere-hour rating ..... 2-8
- B**  
 Battery ..... 6-14  
 Before Operating ..... 4-2  
 Brakes  
   Parking ..... 2-10, 4-6  
   Service ..... 2-10  
 Braking ..... 4-6
- C**  
 Capacity plate ..... 2-3  
 Choke Control ..... 2-9  
 Cold start ..... 4-5  
 Component locations ..... 2-2
- D**  
 Daily inspection ..... 1-2  
 Daily safety inspection ..... 3-2  
 Data plate ..... 2-3  
 Decals  
   Fan warning ..... 2-5  
   Parking brake caution ..... 3-7  
   Safety warning ..... 2-4  
   Seat deck ..... 2-5  
 Direction control lever ..... 2-10, 4-6
- E**  
 Electrical circuit ..... 3-15  
 Emergency starting and towing .. 5-1
- F**  
 Fuel Gauge ..... 2-9  
 Functional checks ..... 3-3
- G**  
 General safety rules ..... 1-1  
 General starting and  
 operating tips ..... 4-3
- H**  
 Horn button ..... 2-9  
 Hour reading ..... 2-9
- How to use battery  
 jumper cables ..... 5-3  
 How to use this manual ..... viii
- I**  
 Introduction ..... i, vi
- K**  
 Key switch ..... 2-7  
 Know your tow tractor ..... 2-1
- M**  
 Maintenance. *See* Planned  
 maintenance.  
 Maintenance intervals ..... 6-7
- N**  
 Nameplate ..... 2-3  
 No riders ..... 1-4
- O**  
 Operating procedures ..... 4-1  
 Operating safely ..... 4-7  
 Operator compartment ..... 2-6  
 Operator protection ..... 1-5  
 Operator maintenance and care 3-1  
 Out of service tag ..... 4-5
- P**  
 Parking ..... 1-6  
 Pedestrians ..... 1-4  
 Planned maintenance ..... 6-1  
   Air cleaning the tow tractor . 6-17  
   Battery ..... 6-14  
   Brakes ..... 6-12  
   Daily maintenance checks .... 6-8  
   Direction control ..... 6-13  
   Functional tests ..... 6-11  
   Hourmeter ..... 6-12  
   Parking brake ..... 6-12  
   Periodic maintenance  
   checks ..... 6-9  
   PM Report Form ..... 6-9  
   Service brake ..... 6-12  
   Steering system ..... 6-13

---

## **P (cont)**

- Visual inspection ..... 6-10
- Wheels and tires ..... 6-11

## **R**

- Refueling LPG tanks ..... 3-5
- Riders ..... 1-4, 4-7

## **S**

- Safety decals ..... 2-4
- Safety messages ..... x
- Safety, operating safely ..... 4-7
- Safety rules ..... 1-1
- Safety signs ..... x
- Safety warning decal ..... 2-4
- Seat adjustment ..... 2-7
- Shut down procedure ..... 4-9
- Specifications ..... 7-1
- Starting and  
operating procedures ..... 4-1
- Starting from a safe condition ... 4-2
- Starting the engine ..... 4-5

## **T**

- Towing precautions ..... 5-2
- Towing procedures ..... 5-2
- Tow tractor description ..... 2-2

## **V**

- Visual checks ..... 3-2, 6-10

## **W**

- Warning decal ..... 2-4
- Warning indicator lights ..... 2-8
- Water temp gauge ..... 2-9



---

Additional copies of this manual may be purchased from  
YOUR AUTHORIZED CLARK DEALER



---

**CLARK** Material Handling  
Company

Lexington, Ky. 40507  
Printed in USA