

# Operator's Manual



INTERNAL COMBUSTION LIFT TRUCKS

Additional copies of this manual may be purchased from  
YOUR AUTHORIZED CLARK DEALER

*[Do not remove this manual from the truck]*

## S 20/25/30/35 D,L,G S 20/25/30/32C L,G

**CLARK MATERIAL HANDLING COMPANY**  
 700 Enterprise Drive • Lexington, Kentucky 40510 [ [www.clarkmhc.com](http://www.clarkmhc.com) ]  
 Printed Date ; Oct. 2022



Part No. 8140450 (Eng)  
 Book No. OM 1067 (Rev 2.3)  
 Mar. 2023  
 © 2017 CLARK Material  
 Handling Company



# Operator's Manual

You must be trained and authorized to operate a lift truck.

## YOU can prevent accidents

First: Learn safe operating rules and your company rules.

Next: Read your Operator's Manual. If you do not understand it, ask your supervisor for help.

Learn about the unit you operate.

## KNOW YOUR TRUCK

Then: Practice operating your truck safely.

And: Keep your truck in safe operating condition with correct and timely maintenance.

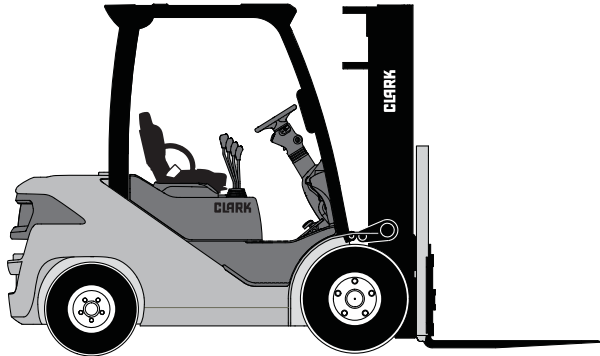

Breaking these rules will cause serious or fatal injury to yourself and others.



## A Message to CLARK Lift Truck Operators

Lift trucks are specialized machines with unique operating characteristics, designed to perform a specific job. Their function and operation is not like a car or ordinary truck. They require specific instructions and rules for safe operation and maintenance.

Safe operation of lift trucks is of primary importance to CLARK. Our experience with lift truck accidents has shown that when accidents happen and people are killed or injured, the causes are:

- **Operator not properly trained**
- **Operator not experienced with lift truck operation**
- **Basic safety rules not followed**
- **Lift truck not maintained in safe operating condition**

For these reasons, CLARK wants you to know about the safe operation and correct maintenance of your lift truck.

This manual is designed to help you operate your lift truck safely. This manual shows and tells you about safety inspections and the important general safety rules and hazards of lift truck operation. It describes the special components and features of the truck and explains their functions. The correct operating procedures are shown and explained. Illustrations and important safety messages are included for clear understanding. A section on maintenance and lubrication is included for the lift truck mechanic.

The operator's manual is not a training manual. It is a guide to help trained and authorized operators safely operate their lift truck by emphasizing and illustrating the correct procedures. However, it cannot cover every possible situation that may result in an accident. You must watch for hazards in your work areas and avoid or correct them. It is important that you know and understand the information in this manual and that you know and follow your company safety rules! Be sure that your equipment is maintained in a safe condition. Do not operate a damaged or malfunctioning truck. Practice safe operation every time you use your lift truck. Let's join together to set high standards in safety.



Remember, before you start operating this lift truck, be sure you understand all driving procedures. It is your responsibility, and it is important to you and your family, to operate your lift truck safely and efficiently. Be aware that the Federal Occupational Safety and Health Act (OSHA) and state laws require that operators be completely trained in the safe operation of lift trucks; it is also an OSHA requirement that a machine inspection be performed before every shift. If you think you need training in operating or inspecting your lift truck, ask your supervisor.

CLARK lift trucks are built to take hard work, but not abuse. They are built to be dependable, but they are only as safe and efficient as the operator and the persons responsible for maintaining them. Do not make any repairs to this truck unless you have been trained in safe lift truck repair procedures and are authorized by your employer.



### **CAUTION**

**This forklift burns fuel, which will produce exhaust gases that are harmful to humans. They include carbon monoxide, carbon dioxide, nitrogen oxides and hydrocarbons. The amounts of each of these gases will vary, depending on a number of related factors. With the correct fuel, proper tuning of the system by technicians and adequate ventilation, this truck can produce emissions that are considered safe for indoor use. Of the four gases, carbon monoxide poses the greatest threat. Carbon monoxide symptoms may vary with individuals, depending on breathing rate, the amount of work or exercise being performed at the time of exposure, and the physical state of the subject. In case of working in an enclosed area, the area should be well ventilated. We recommend the forklift not be operated in a small enclosed area for long periods. To maintain the emission levels to a normal level, customers are requested to follow the maintenance schedule. A truck using diesel fuel is not recommended indoor use.**



**SAFETY STARTS WITH YOU**  
**(Safety Video)**



2840950



# Contents of this Manual

<b>A Message to CLARK Lift Truck Operators.....</b>	<b>ii</b>
<b>Introduction .....</b>	<b>vi</b>
<b>How to Use this Manual .....</b>	<b>viii</b>
<b>Safety Signs and Safety Messages .....</b>	<b>x</b>
<b>Section 1. General Safety Rules .....</b>	<b>1-1</b>
<b>Section 2. Operating Hazards .....</b>	<b>2-1</b>
<b>Section 3. Operator Compartment and Controls .....</b>	<b>3-1</b>
<b>Section 4. Operating Procedures .....</b>	<b>4-1</b>
<b>Section 5. Operator Maintenance and Care .....</b>	<b>5-1</b>
<b>Section 6. Emergency Starting, Towing and Lowering ....</b>	<b>6-1</b>
<b>Section 7. Planned Maintenance and Lubrication .....</b>	<b>7-1</b>
<b>Section 8. Specifications .....</b>	<b>8-1</b>



## Introduction

CLARK welcomes you to the growing group of professionals who own, operate, and maintain CLARK lift trucks. We take pride in the long tradition of quality products and superior value the CLARK name represents. This manual familiarizes you with safety, operating, and maintenance information about your new lift truck. It has been specially prepared to help you use and maintain your CLARK lift truck in a safe and correct manner.

Your CLARK lift truck has been designed and built to be as safe and efficient as today's technology can make it. As manufactured, it meets all the applicable mandatory requirements of ANSI / ITSDF B56.1 Safety Standard for Powered Industrial Trucks. Each truck is also furnished with equipment to help you operate safely; for example, load back rest, parking brake, safety restraint system, seat belts and horn are standard equipment.

Safe, productive operation of a lift truck requires both skill and knowledge on the part of the operator. The operator must know, understand, and practice the safety rules and safe driving and load handling techniques described in this manual. To develop the skill required, the operator must become familiar with the construction and features of the lift truck and how they function. The operator must understand its capabilities and limitations, and see that it is kept in a safe condition.

### **Routine Servicing and Maintenance**

Regular maintenance and care of your lift truck are not only important for economy and utilization reasons; it is essential for your safety. A faulty lift truck is a potential source of danger to the operator, and to other personnel working near it. As with all quality equipment, keep your lift truck in good operating condition by following the recommended schedule of maintenance.





## **Operator Daily Inspection - Safety and Operating Checks**

A lift truck should always be examined by the operator, before driving, to be sure it is safe to operate. The importance of this procedure is emphasized in this manual with a brief illustrated review and later with more detailed instructions. CLARK dealers can supply copies of a helpful "Drivers Daily Checklist."

## **Planned Maintenance**

In addition to the daily operator inspection, CLARK recommends that a planned maintenance and safety inspection program (PM) be performed by a trained and authorized mechanic on a regular basis. The PM will provide an opportunity to make a thorough inspection of the safety and operating condition of your lift truck. Necessary adjustments and repairs can be done during the PM, which will increase the life of components and reduce unscheduled downtime and increase safety. The PM can be scheduled to meet your particular application and lift truck usage.

The procedures for a periodic planned maintenance program that covers inspections, operational checks, cleaning, lubrication, and minor adjustments are outlined in this manual. Your CLARK dealer is prepared to help you with a Planned Maintenance Program by trained service personnel who know your lift truck and can keep it operating safely and efficiently.

## **Modification of the truck prohibited**

Unauthorized modification of the truck is not permitted, and, in case that a problem has occurred due to a modification without permission, the warranty service shall not be provided.

For instance, the modifications which may void the warranty include those that may negatively affect the performance, durability and safety of the truck due to addition of unauthorized electrical devices (lamp, black box, electrical instrument, communication equipment, etc.), braking system, steering system, vision improvement system and detachable attachment device that were not mounted when the equipment was shipped out of the factory.



## How to Use this Manual

This manual is a digest of essential information about the safe operation, the features and functions and explains how to maintain your lift truck. This manual is organized into eight major parts:

**Section 1, General Safety Rules**, reviews and illustrates accepted practices for safe operation of a lift truck.

**Section 2, Operating Hazards**, warns of conditions that could cause damage to the truck or injury to the operator or other personnel.

**Section 3, Operator Compartment and Controls**, describes the operating components, systems, controls, and other features of your truck and tells how they function.

**Section 4, Operating procedures**, discusses specific instructions on the safe, efficient operation of your lift truck.

**Section 5, Operator Maintenance and Care**, presents details on how to perform the operator's daily safety inspection and refuel the lift truck.

**Section 6, Emergency Starting, Towing and Lowering**, gives instructions for towing your truck in an emergency and for using battery jumper cables to start your truck in an emergency.

**Section 7, Planned Maintenance and Lubrication**, describes the PM program.

**Section 8, Specifications**, provides reference information and data on features, components, and maintenance items.

**NOTICE:** The descriptions and specifications included in this manual were in effect at the time of printing. CLARK Material Handling Company reserves the right to make improvements and changes in specifications or design. Please check with your authorized CLARK dealer for information on possible updates or revisions.

The examples, illustrations, and explanations in this manual should help you improve your skill and knowledge as a professional lift truck operator and take full advantage of the capabilities and safety features of your new lift truck.

The first Section of the manual is devoted to a review, with illustrations and brief messages, of general safety rules and the major operating hazards you can encounter while operating a lift truck. Next, you will find descriptions of the components of your specific lift truck model and how the instruments, gauges, and controls operate. Then, you will find a discussion of safe and efficient operating procedures, followed by instructions on how to tow a disabled lift truck. The later sections of the manual are devoted to maintenance and truck specifications.

Take time to carefully read the “Operator Compartment and Controls” section. By acquiring a good basic understanding of your truck’s features, and how they function, you are better prepared to operate it both efficiently and safely.

In “Planned Maintenance and Lubrication,” you will find essential information for correct servicing and periodic maintenance of your truck, including charts with recommended maintenance intervals and component capacities. Carefully follow these instructions and procedures.

Each major Section has its own table of contents, so that you can find the various topics more easily. If you cannot find a topic in the table of contents, check the index at the back of the manual.

We urge you to first carefully read the manual from cover to cover. Take time to read and understand the information on general safety rules and operating hazards. Acquaint yourself with the various procedures in this manual. Understand how all gauges, indicator lights, and controls function. Please contact your authorized CLARK dealer for the answers to any questions you may have about your lift truck’s features, operation, or manuals.

Operate your lift truck safely; careful driving is your responsibility. Drive defensively and think about the safety of people who are working nearby. Know your truck’s capabilities and limitations. Follow all instructions in this manual, including all IMPORTANT, CAUTION, WARNING, and DANGER messages to avoid damage to your lift truck or the possibility of any harm to yourself or others.

This manual is intended to be a permanently attached part of your lift truck. Keep it on the truck as a ready reference for anyone who may drive or service it. If the truck you operate is not equipped with a manual, ask your supervisor to obtain one and have it attached to the truck. And, remember, your CLARK dealer is pleased to answer any questions about the operation and maintenance of your lift truck and will provide you with additional information should you require it.



## Safety Signs and Safety Messages

Improper operation can cause accidents. Don't take chances with incorrect or damaged equipment. **Read** and **understand** the procedures for safe driving and maintenance outlined in this manual. Don't hesitate to ask for help. **Stay alert!** Follow safety rules, regulations, and procedures. Avoid accidents by recognizing dangerous procedures or situations before they occur. **Drive and work safely** and follow the safety signs and their messages on the truck and in this manual.

**Safety signs and messages** are placed in this manual and on the truck to provide instructions and identify specific areas where potential hazards exist and special precautions should be taken. Know and understand the meaning of these instructions, signs, and messages. Damage to the truck, death, or serious injury to you or other persons may result if these messages are not followed. If warning decals are damaged, they must be replaced. Contact your CLARK dealer for replacements.

### NOTICE

This message is used when special information, instructions or identification are required relating to procedures, equipment, tools, pressures, capacities and other special data.

### IMPORTANT

This message is used when special precautions should be taken to ensure a correct action or to avoid damage to or malfunction of the truck or a component.



### CAUTION

Indicates a potentially hazardous situation which, if not avoided, may result in minor or moderate injury. It may also be used to alert against unsafe practices.



### WARNING

Indicates a potentially hazardous situation which, if not avoided, could result in death or serious injury.



### DANGER

Indicates an imminently hazardous situation which, if not avoided, will result in death or injury



# General Safety Rules

## Contents

Contents .....	1-1
Daily Inspection .....	1-2
Do's and Don'ts .....	1-3
Seat Belts .....	1-4
No Riders .....	1-5
Pedestrians .....	1-6
Operator Protection .....	1-7
Fork Safety .....	1-8
Pinch Points .....	1-9
Travel .....	1-10
Grades, Ramps, Slopes, and Inclines .....	1-11
Surface and Capacity .....	1-12
Tip-Over .....	1-13
What to do in Case of a Tip-over .....	1-14
Parking .....	1-15
General Tire Maintenance, Inspection, and Repair ....	1-16
Carbon Monoxide and Fumes.....	1-17



# Daily Inspection

**CLARK** Material Handling Company  
 OPERATORS' DAILY CHECKLIST  
 Check Each Item Before Start Of Each Shift

Date: \_\_\_\_\_

Check one:  Gas/LPG/Diesel Truck  Electric Sit-down  Electric Stand-up  Electric Pallet

Truck Serial Number: \_\_\_\_\_ Operator: \_\_\_\_\_ Supervisor's OK: \_\_\_\_\_

Hour meter reading: \_\_\_\_\_

Check each of the following items before the start of each shift. Let your supervisor and/or maintenance department know of any problem.  
 DO NOT OPERATE A FAULTY TRUCK. Your safety is at risk.  
 After checking, mark each item accordingly. Explain below as necessary.

Check boxes as follows:  OK  NG, needs attention, or repair. Circle problem and explain below

OK	NG	VISUAL CHECKS	OK	NG	OPERATIONAL CHECKS
<input type="checkbox"/>	<input type="checkbox"/>	Tires/Wheels: wear, damage, nuts tight	<input type="checkbox"/>	<input type="checkbox"/>	Engine: runs rough, noisy, leaks
<input type="checkbox"/>	<input type="checkbox"/>	Head/Tail/Working Lights: damage, mounting, operation	<input type="checkbox"/>	<input type="checkbox"/>	Steering: loose/binding, leaks, operation
<input type="checkbox"/>	<input type="checkbox"/>	Gauges/Instruments: damage, operation	<input type="checkbox"/>	<input type="checkbox"/>	Service Brake: linkage loose/binding, stops OK, grab
<input type="checkbox"/>	<input type="checkbox"/>	Operator Restraint: damage, mounting, operation, oily, dirty	<input type="checkbox"/>	<input type="checkbox"/>	Parking Brake: loose/binding, operational, adjustment
<input type="checkbox"/>	<input type="checkbox"/>	Warning Decals/Operator's Manual: missing, not readable	<input type="checkbox"/>	<input type="checkbox"/>	Seat Brake (if equipped): loose/binding, operational, adjustment
<input type="checkbox"/>	<input type="checkbox"/>	Data Plate: not readable, missing	<input type="checkbox"/>	<input type="checkbox"/>	Horn: operation
<input type="checkbox"/>	<input type="checkbox"/>	Overhead Guard: bent, cracked, loose, missing	<input type="checkbox"/>	<input type="checkbox"/>	Backup Alarm (if equipped): mounting, operation
<input type="checkbox"/>	<input type="checkbox"/>	Load Back Rest: bent, cracked, loose, missing	<input type="checkbox"/>	<input type="checkbox"/>	Warning Lights (if equipped): mounting, operation
<input type="checkbox"/>	<input type="checkbox"/>	Forks: bent, worn, stops OK	<input type="checkbox"/>	<input type="checkbox"/>	Lift/Lower: loose/binding, excessive drift, leaks
<input type="checkbox"/>	<input type="checkbox"/>	Engine Oil: level, dirty, leaks	<input type="checkbox"/>	<input type="checkbox"/>	Tilt: loose/binding, excessive drift, "chatters," leaks
<input type="checkbox"/>	<input type="checkbox"/>	Hydraulic Oil: level, dirty, leaks	<input type="checkbox"/>	<input type="checkbox"/>	Attachments: mounting, damaged, operation, leaks
<input type="checkbox"/>	<input type="checkbox"/>	Radiator: fluid level, dirty, leaks	<input type="checkbox"/>	<input type="checkbox"/>	Battery Test (electric trucks only): indicator in green while holding full forward tilt
<input type="checkbox"/>	<input type="checkbox"/>	Fuel: level, leaks	<input type="checkbox"/>	<input type="checkbox"/>	Control Levers: loose/binding, freely return to neutral
<input type="checkbox"/>	<input type="checkbox"/>	Battery: connections loose, charge, electrolyte low	<input type="checkbox"/>	<input type="checkbox"/>	Directional Control: loose/binding, find neutral OK
<input type="checkbox"/>	<input type="checkbox"/>	Covers/Sheetmetal: damaged, missing			
<input type="checkbox"/>	<input type="checkbox"/>	Brakes: linkage, reservoir fluid level, leaks, debris on floor			

Explanation of problems marked above:

\_\_\_\_\_

\_\_\_\_\_

\_\_\_\_\_

\_\_\_\_\_

\_\_\_\_\_

\_\_\_\_\_

\_\_\_\_\_

\_\_\_\_\_

\_\_\_\_\_

\_\_\_\_\_

\_\_\_\_\_

\_\_\_\_\_

At the beginning of each shift, inspect your truck and fill out a daily inspection sheet.

Check for damage and maintenance problems.

Have repairs made before you operate the truck.



**CAUTION**

**DO NOT MAKE REPAIRS YOURSELF.** Lift truck mechanics are trained professionals. They know how to make repairs safely. (See Section 5)



## Do's and Don'ts



Don't mix drugs or alcohol with your job.

Do watch for pedestrians.



Don't block safety or emergency equipment.

Do wear safety equipment when required.



Don't smoke in "NO SMOKING" areas or when refueling.

Don't use the similar fuel.



If forklift truck is to be operated outdoors during rainy conditions, make sure cab is in place to prevent damage to electrical components.

## Seat Belts



**ALWAYS BUCKLE UP**

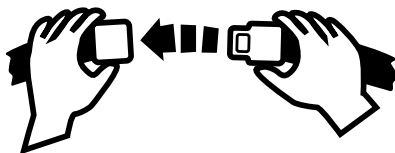

**Seat belts can reduce injuries.**



## No Riders

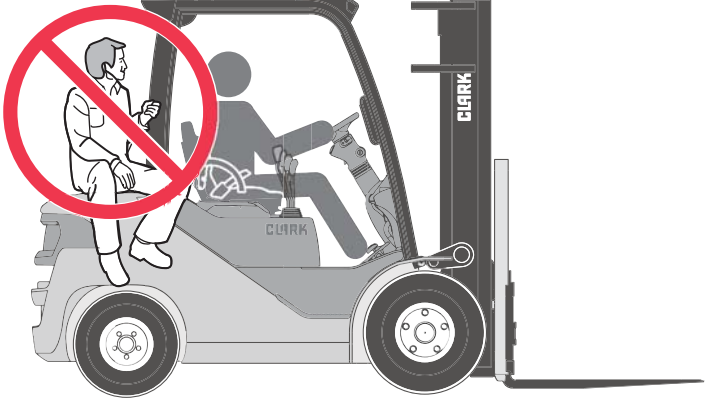

The operator is the only one who should be on a truck.

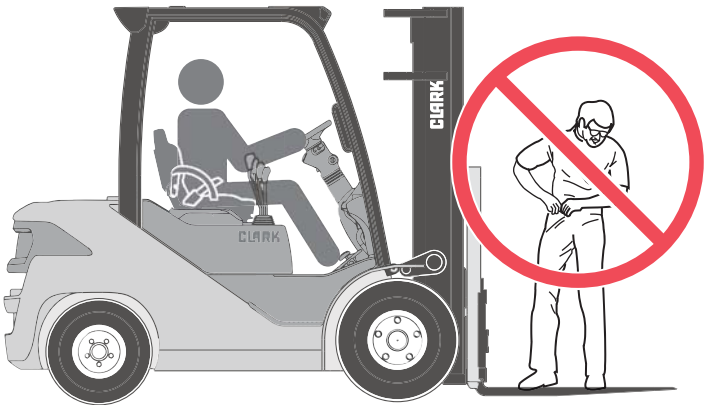

Never transport personnel on the forks of a lift truck.

## Pedestrians

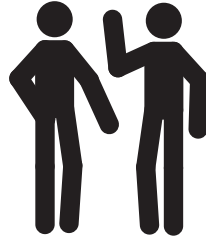

**Watch where you are going. Look in the direction of travel. Pedestrians may use the same roadway you do. Sound your horn at all intersections or blind spots. Watch for people in your work area even if your truck has warning lights or alarms. People may not watch for you.**

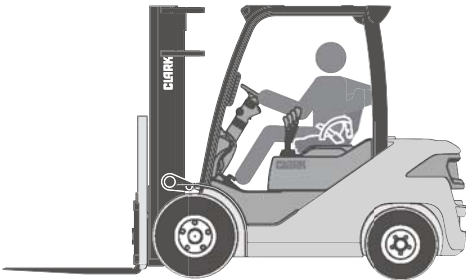

**Make people stand back, even when you are parked.**

## Operator Protection

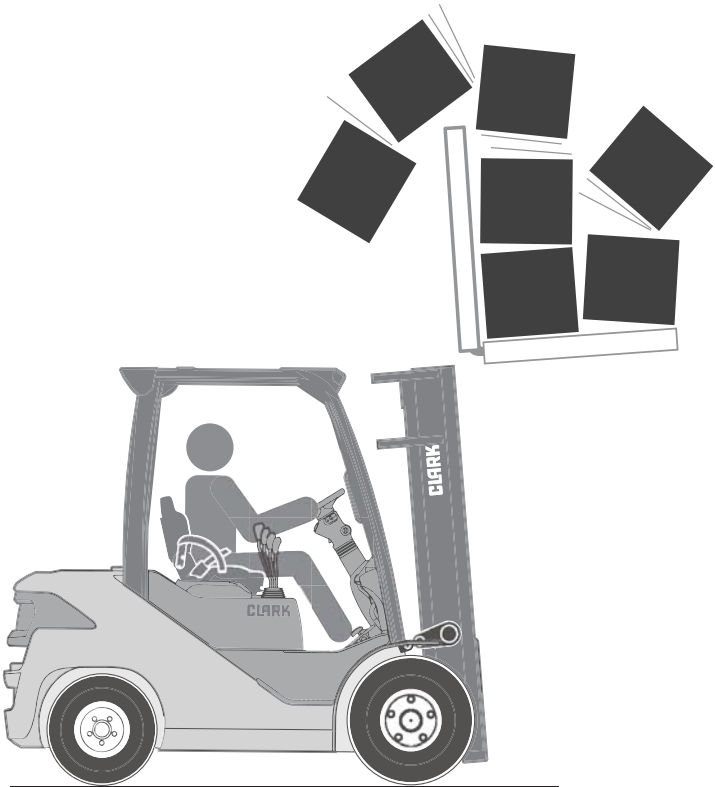

**Keep under the overhead guard.  
Always keep your body within the confines of the truck.**

## Fork Safety

Never allow anyone to walk under raised forks.



**DANGER**

There is special equipment to raise people for overhead work. **DO NOT USE LIFT TRUCKS.**



## Pinch Points

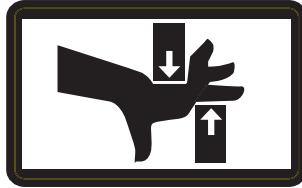

### WARNING

Keep hands, feet and legs out of the upright.



### WARNING

Don't use the upright as a ladder.



### CAUTION

Never try to repair the upright, carriage, chain, or attachment yourself! Always get a trained mechanic.

## Travel

Travel with the load near the floor/ground with upright tilted back to cradle the load whenever possible.

Never lift or lower the load when the truck is in motion.

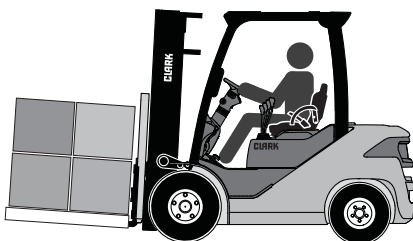

When handling bulky loads that restrict your vision operate your truck in reverse to improve visibility.

Be sure to pivot in the seat to give maximum visibility.

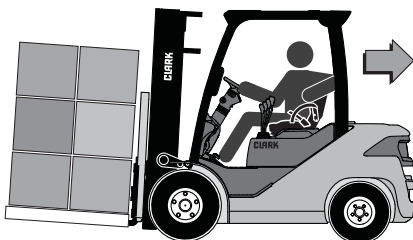

Unstable loads are a hazard to you and to your fellow workers.

Always make certain that the load is well stacked and evenly positioned across both forks.

Never attempt to lift a load with only one fork.

Right

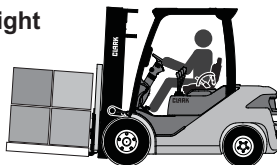

Wrong



## Grades, Ramps, Slopes, and Inclines

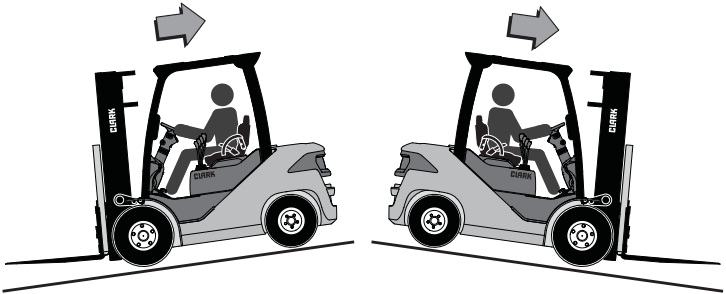

**Unloaded**  
**Forks Downgrade**



### **WARNING**

Never turn on a grade, either loaded or unloaded.

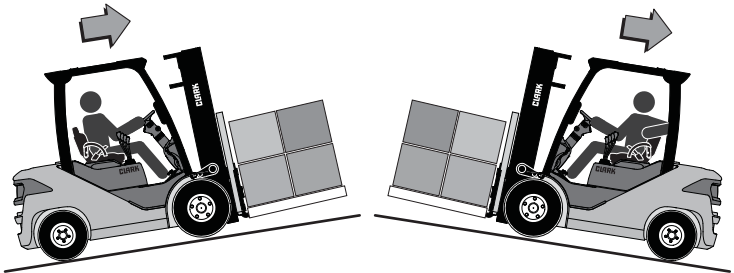

**Loaded**  
**Forks Upgrade**

## Surface and Capacity

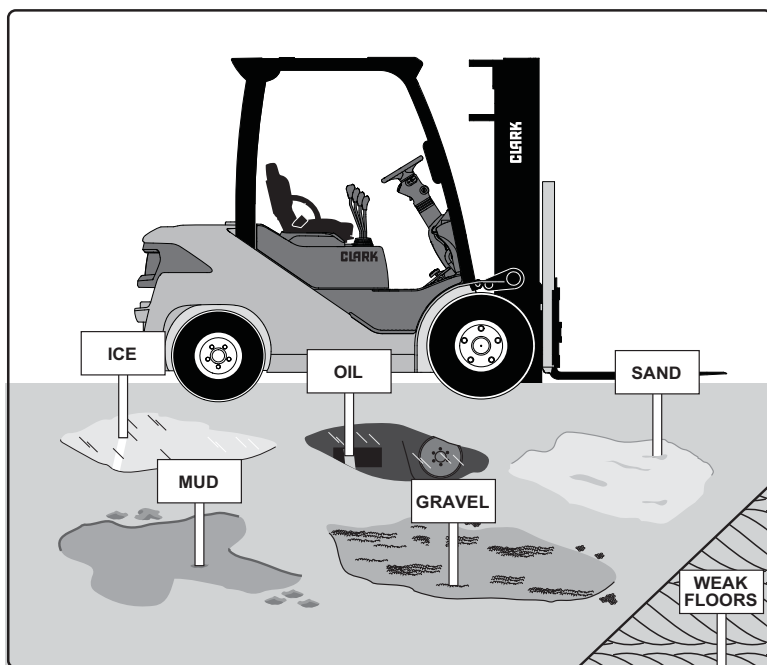

Avoid these conditions. They can cause a truck to tip over or lose traction for braking or driving.

### WARNING

Know the weight of your truck and load. Especially when using elevators. Know the capacity of the elevator you intend to use. Do not overload.

### IMPORTANT

Seat belts can reduce injuries.  
ALWAYS BUCKLE UP

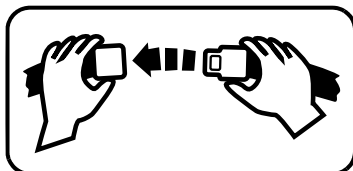



## Tip-Over

### Lateral Tip-over

- Lateral tip-over can occur with a combination of speed and sharpness of turn. This combination will exceed the stability of the truck. This condition is even more likely with an unloaded truck.
- With the load or upright raised, lateral tip-over can occur while turning and/or braking when traveling in reverse or accelerating and turning while traveling forward.
- Lateral tip-over can occur loaded or unloaded by turning on an incline or ramp.

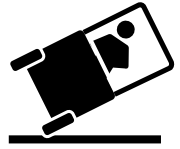

### Longitudinal Tip-over

- Longitudinal tip-over can occur with a combination of overloading and load elevated also with capacity load and elevated. This combination will exceed the stability of the truck. This condition is even more likely with excessive forward tilt, braking in forward travel or accelerating rearward.
- Longitudinal tip-over can occur by driving with the load down slope on a steep grade.
- Never travel with a load elevated more than necessary.

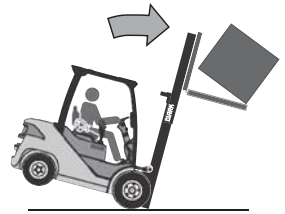

Lateral and longitudinal tip-over can occur if the truck is driven over objects on the floor or ground, off the edge of improved surfaces, or into potholes in the road surface, or by running into overhead objects or collisions.

An off dock type of tip-over can occur if the truck is steered too close to the dock edge, driven off the edge of the dock or ramp, or if the highway truck or trailer rolls away from the dock or is driven away during loading.



### WARNING

The conditions listed above can be further aggravated by overloading, excessive tilt, or off center loads.

### IMPORTANT

Lift truck tip-over can cause serious injury or death if the operator is trapped between the truck and the ground.

## What to do in Case of a Tip-over

If your truck starts to tip over,

**⚠ WARNING**  
**DO NOT JUMP!!!**

### IMPORTANT

Your chances for survival in a tip-over are better if you stay with the truck, in your seat.

**Brace yourself as illustrated below!**

1. Make sure your seat belt is fastened securely.
2. Stay in your seat.
3. Grip the wheel.
4. Brace your feet.



## Parking

- Never park on a grade.
- Always come to a complete stop before leaving truck.

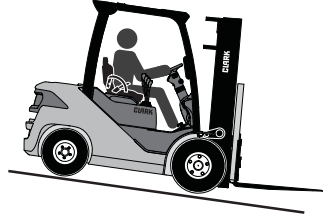

- Be sure travel control is in NEUTRAL.
- Lower forks fully to floor and tilt forward.

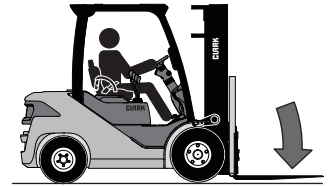

- Set the parking brake by pressing the Parking Brake Switch.
- For additional information, refer to page(s) 3-31 and 3-46.

Parking Brake Switch

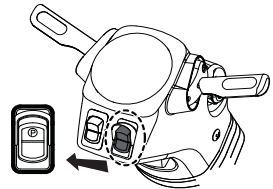

- Turn key to OFF position.

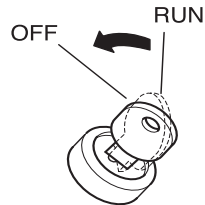

## General Tire Maintenance, Inspection, and Repair

1. Park the truck as described on page 1-15 and check for correct tire inflation air pressure. See specifications in this OM for correct tire pressure for your truck.



### CAUTION

Check tire pressure from a position facing the tread of the tire, not the side. Use a long-handled gauge to keep your body away from the side.



- If tires are low, do not add air. Have the tire and wheel inspected by a person trained and authorized to do tire and wheel maintenance. The tire may require removal and repair.
- Incorrect (low) tire pressure can reduce the stability of a lift truck and cause it to tip over.

### IMPORTANT

Check wheels and tires for damage every time you check tire pressure. Make repairs when needed. Dirt can get into cuts and cause damage to the tire cord and tread. Remove debris from all cuts.



### CAUTION

Multiple wheel assemblies. Do not loosen or remove wheel assembly nuts before fully deflating tire. Have only a trained and authorized mechanic make repairs. See *Service Manual* for more detailed information.

## Carbon Monoxide and Fumes

Be sure your employees understand that they must not use an internal combustion engine in a closed area such as a cold storage locker. Carbon monoxide is a colorless, odorless, poisonous gas which can overcome your employees without warning. This gas is the product of incomplete burning of any material containing carbon, such as gasoline, LP and natural gas, and diesel fuel.

Internal combustion engines that use these fuels are sources of exposure in the workplace. Control of carbon monoxide levels in the workplace is dependent on ventilation and proper maintenance of carbon monoxide producers including internal combustion-powered equipment.

Properly running internal combustion engines will still produce carbon monoxide emissions and deplete the oxygen supply sufficiently, affecting the quality of ambient air in the work environment if the ambient air exchange is not adequate. Always use ventilation as the primary means of control by providing necessary air exchange capability.

Ventilation shall be provided in enclosed areas where internal combustion-powered equipment is used to maintain an atmosphere that shall not exceed the contamination levels specified by the American Conference of Governmental Industrial Hygienists, "Threshold Limit Values of Airborne Contaminants." (See 29 CFR 1910.1000 Table Z-1.) This includes the atmosphere within the truck cab when a cab is provided.

Common symptoms of carbon monoxide exposure may include headaches, dizziness, and nausea. If employees exhibit these symptoms, move them into fresh air, seek medical attention as required, and determine the source of carbon monoxide by monitoring "threshold limit values" in areas of exposure.

Questions concerning degree of concentration and methods of sampling to ascertain the conditions present should be referred to a qualified professional. Users must follow applicable local, state, and federal regulations that apply to their workplace.



# Operating Hazards

## Contents

Loose Loads .....	2-2
Long and Wide Loads / Rear Swing .....	2-3
Low Overhead Clearance	
Fast Turns and High Loads .....	2-4
Drop-Offs .....	2-5
Right-Angle Stacking .....	2-6
Chain Slack .....	2-7
Pallets and Skids .....	2-8

### IMPORTANT

This section shows some of the hazards that may cause you, or someone around you, to be killed or badly hurt. As the operator, you must look for other hazards. Get your supervisor to help you identify and avoid those hazards.



## Loose Loads

**Loose or unbalanced loads are dangerous. Observe these precautions.**

Never carry loose or uneven material.

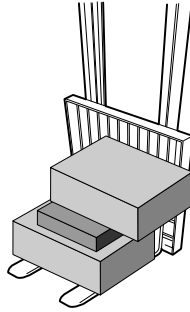

Center wide loads.

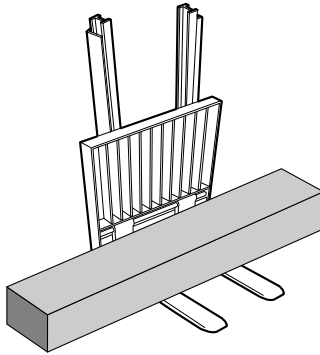

Stack and band loose material.

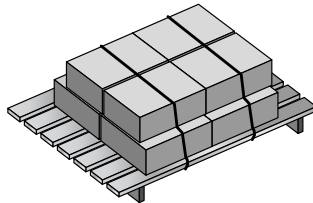



## Long and Wide Loads / Rear Swing

### WARNING

**With long or wide loads, you need more room. So slow down and watch your clearance.**

**A long load reduces the capacity of the truck. Know and understand your truck load rating.**

When extra-long material makes it necessary to travel with the load elevated, do so with extreme care and be alert to load end-swing when turning.

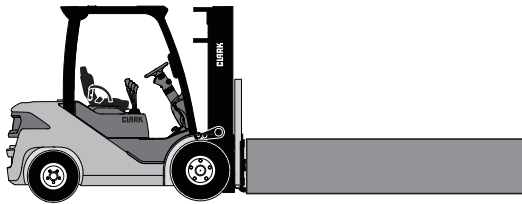

### WARNING

**When turning, be sure the rear end of the truck does not swing into racks, posts, etc. Watch for pedestrians beside the truck.**

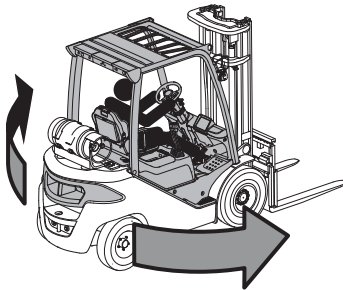

## Low Overhead Clearance· Fast Turns and High Loads



### WARNING

Know the height of your truck, with and without a load.

Check your clearances.

Keep the load low and tilted back.

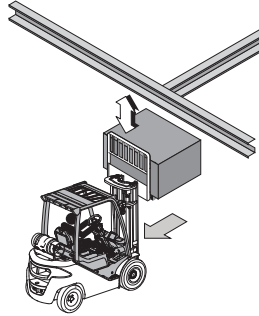

### WARNING

Watch overhead clearance:

Moving into overhead structures can tip a truck over, or spill a load.

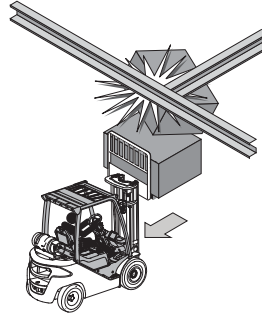

### WARNING

Slow down before turning. The truck can tip over.

Turn too sharp with a raised load and your truck can tip even at slow speeds.

Travel with a load raised only when removing or depositing a load.

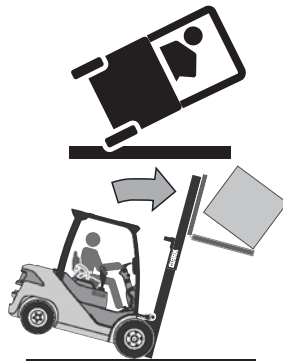

## Drop-Offs

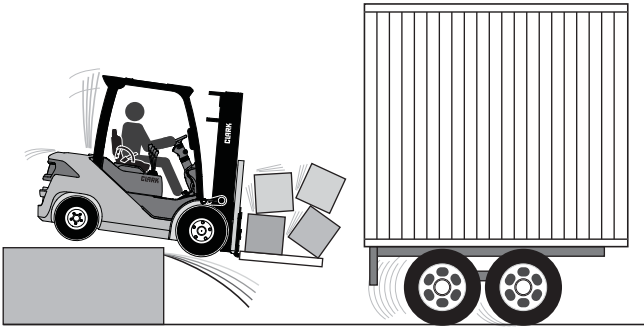

### WARNING

To avoid these hazards, you must:

- Talk to the truck driver yourself; make sure the driver does not move the trailer until you are done!
- Apply trailer brakes.
- Use wheel chocks.
- Use trailer-to-dock locking system if available.

The impact of moving in and out of a trailer may cause the trailer to creep or move.



## Right-Angle Stacking

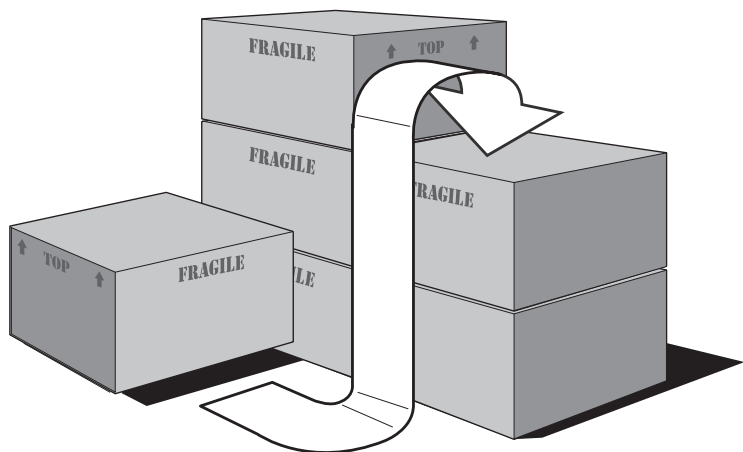

**SLOWLY**

When right-angle stacking or moving with a raised load to clear low objects, avoid sharp turns and move slowly.

## Chain Slack

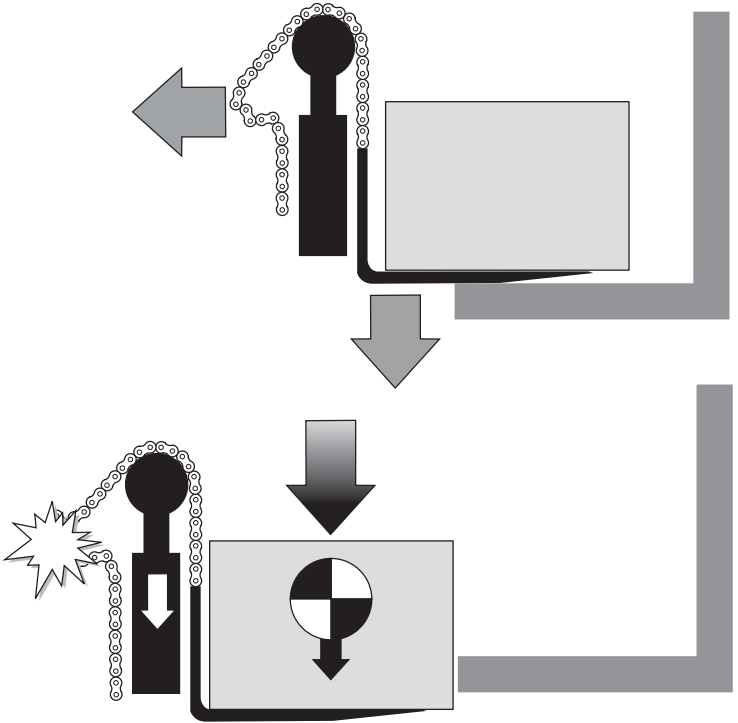

### WARNING

Slack chains mean rail or carriage hang-up. Raise the forks before you move, or broken chains can result.

## Pallets and Skids

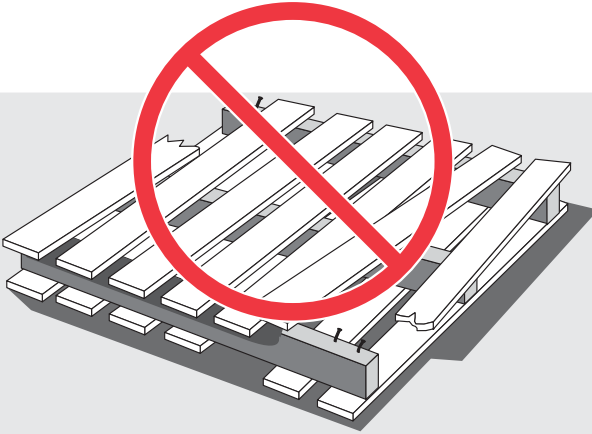

### **WARNING**

**Do not move or store materials on damaged pallets or skids. Items can fall through them causing severe injury or death!**

**Be sure the pallet or skid you are using is in good condition and does not have defective or missing components and fasteners.**

# Operator Compartment and Controls

## Contents

Truck Description .....	3-2
Operator Compartment .....	3-3
Instrument Pod .....	3-4
Display .....	3-6
Operator Controls .....	3-45



## Truck Description

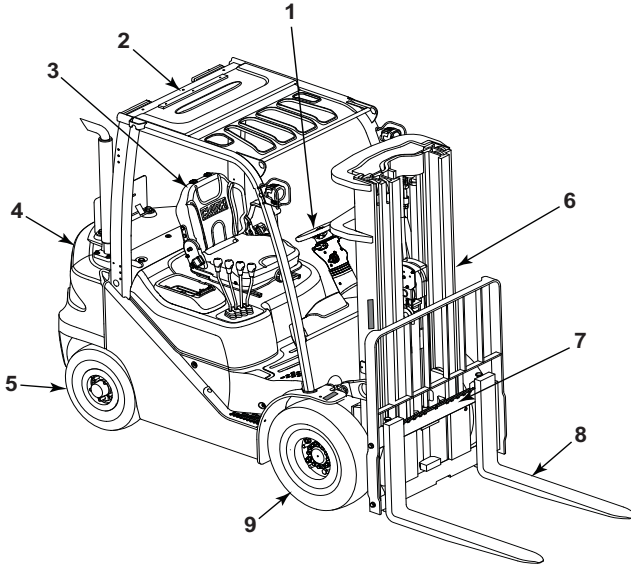

1. Steering Handwheel
2. Overhead Guard
3. Seat and Seat Belt
4. Counterweight
5. Steer Axle, Wheels / Tires
6. Upright and Carriage
7. Load Backrest
8. Forks
9. Drive Axle, Wheels / Tires

The truck shown above is a typical representation of a CLARK internal combustion lift truck. Your model may vary slightly.



## Operator Compartment

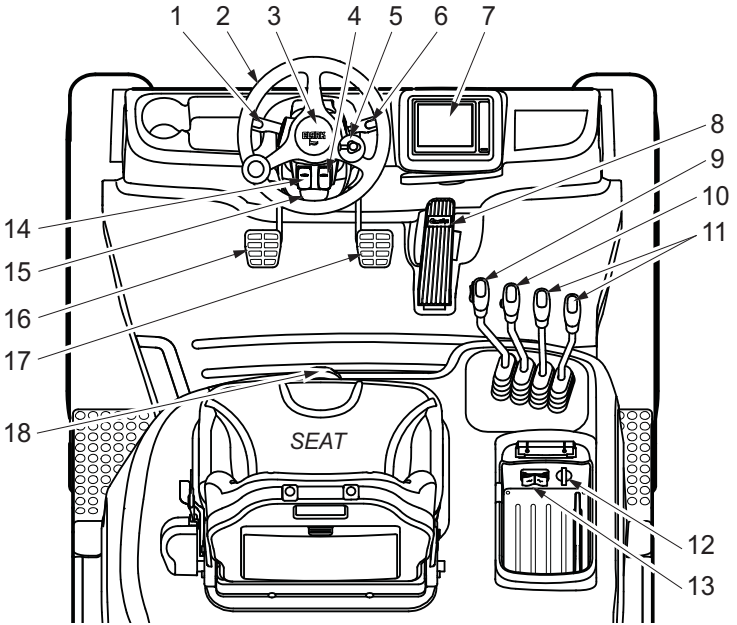

S20330202

- |                            |                              |
|----------------------------|------------------------------|
| 1. Forward / Reverse Lever | 10. Tilt Control Lever       |
| 2. Steering Handwheel      | 11. Auxiliary Control Lever  |
| 3. Horn Button             | 12. Power Socket (12V)       |
| 4. Parking Brake Switch    | 13. USB Charger              |
| 5. Key Switch              | 14. Hazard Switch            |
| 6. Turn Signal Lever       | 15. Column Adjust Button     |
| 7. Instrument Pod          | 16. Inching Pedal            |
| 8. Accelerator Pedal       | 17. Service Brake Pedal      |
| 9. Lift Control Lever      | 18. Driver's Weight Adjuster |

## Instrument Pod

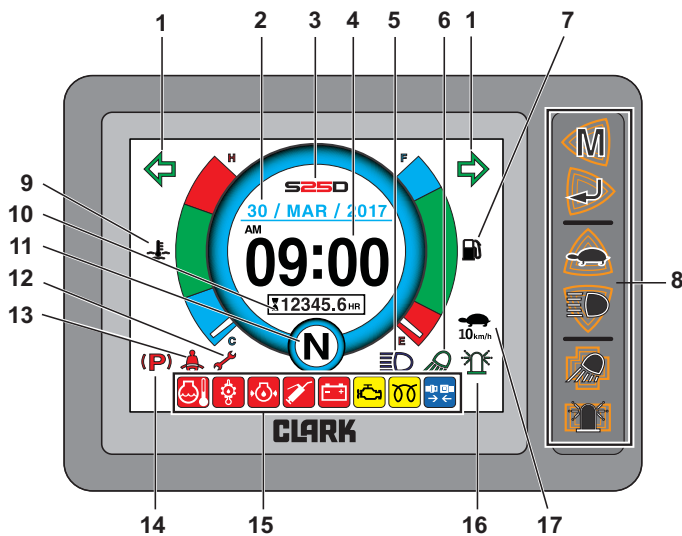

1. Turn Signal Indicator (*Optional*)
2. Date Indicator
3. Truck Model Indicator
4. Time Indicator
5. Head Light Indicator
6. Rear Work Light Indicator
7. Fuel Level Indicator
8. Mode Select Switch (Membrane Switch)
9. Coolant Temperature Gauge
10. Hour Meter (or Trip Distance) Indicator
11. Direction Indicator
12. Fault Icon
13. Seat Belt Reminder Icon
14. Parking Brake Icon
15. Warning Symbols
16. Strobe Light and Blue Dot Light
17. Speed Limit Function Indicator (*Optional*)

## Functions

### 1. General function

The instrument pod consists of indicator lights, an hour meter, a circuit board and attached gauges. The pod provides the operator with important information about truck conditions and can shut down the truck in the event that certain critical conditions are present.

### 2. Engine shutdown function

The instrument pod circuit board receives signals from sensors in various locations and shuts down the truck when transmission fluid temperature is excessive or engine oil pressure is low. Before shutting down the truck, the instrument pod sounds alarm for 20-30 seconds and flashes indicator lights. After shutdown, the truck may be restarted, but if the fault condition persists, the truck will shut down again.

### 3. Neutral start function and Anti-restart function

#### 1) Neutral start function

The instrument pod will not allow the starter to be engaged if directional switches are closed or key has been in start position once. Key switch must always be turned OFF to restart engine.

#### 2) Anti-restart function

When engine is already running, the start motor does not rotate although the key switch is turned to the start position.

## IMPORTANT

**For safety reasons, every CLARK forklift truck is fitted with a neutral start device. The purpose of this is to prevent the engine from being started while the transmission is in gear. Thus the engine may only start when the direction control lever is in the neutral position.**

### 4. Anti-drive and parking brake reminder function

The parking brake is automatically applied and released. In the case of a malfunction, the brake may need to be manually released to allow the truck to be towed, refer to 6-3.

# Display

## 1. TFT LCD

### Standard

Speed meter activated if speed more than 1 km/h (0.6 mph)

1. Time Indicator
2. Speed meter

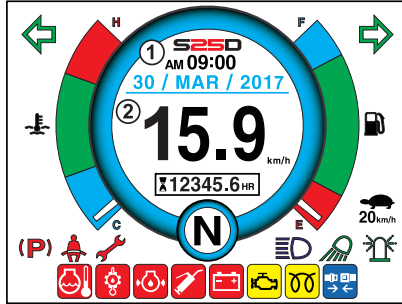

### Optional

Function activated like weight when speed is less 1 km/h (0.6 mph)

1. Weight Indicator (Optional)
2. LPG Fuel Indicator

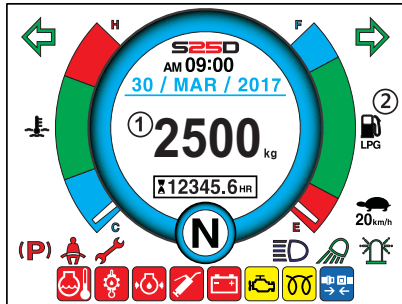

## 2. Mode Select Switch (Membrane Switch)

### Left arrow button (Mode button)

1. When pressing this button at normal condition, it will move to the Menu mode.
2. At menu mode, this switch is used for moving to left menu.
3. At the top level menu, move back to the normal operating mode.



### Right arrow button (Enter button)

1. At the menu mode, this switch is used for moving to right menu.
2. Save the values with this enter button, password changing or adjusting value in sub menu.



### Upper arrow button (Turtle select button)

1. At the menu mode, this switch is used for moving to higher menu.



### Down arrow button (Work light button)

1. At the menu mode, this switch is used for moving to the lower menu.
2. At normal condition, work light switch function is performed.



### Plus button (Rear work light button)

1. At the menu mode, the data value is increased to target value.
2. At normal condition, rear work light switch function performed.
3. At the menu mode, if pushing for over 1 second, the changing value speed is increased.



## Minus button (Strobe light or Blue dot light button)

1. At the menu mode, the data value is reduced to target value.
2. At normal condition, strobe light switch function performed.
3. At the menu mode, if pushing for over 1 second, the changing value speed will decrease.



## 3. Indication of Display (Turn on the key switch)

### Key on

1. Show "CLARK" until main screen booted.



2. Show the main screen with 1 time single beep.

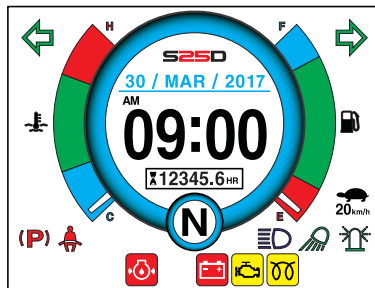

## Turn Signal Indicator (Optional)

1. Show left arrow for LH turn signal and right arrow for RH turn signal.



### Coolant Temperature Indicator

Show current truck coolant temperature.

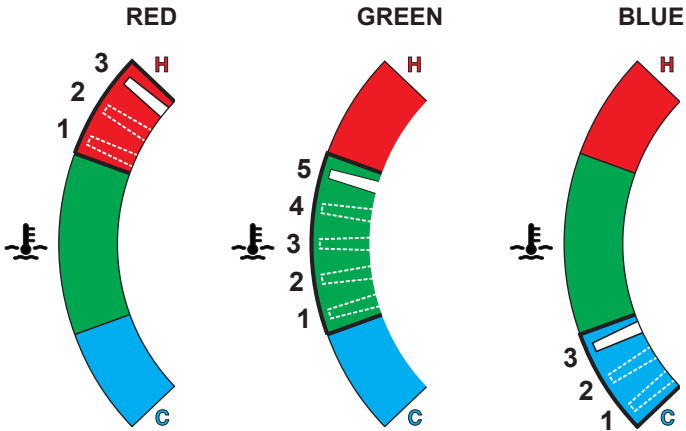

### 3-Zone specification

Zone	Gauge Step	Truck Engine Type				
		YANMAR	ISUZU	PSI	FORD RANGER	FORD OLD/HMC THETA
RED (Top)	4	118°C ~	112°C ~	108°C ~	118°C ~	123°C ~
	3	116~117°C	110~111°C	106~107°C	115~117°C	120~122°C
	2	113~115°C	100~109°C	104~105°C	112~114°C	117~119°C
	1	110~112°C	98~99°C	100~103°C	110~111°C	115~116°C
GREEN (Middle)	5	101~109°C	91~97°C	91~99°C	107~109°C	112~114°C
	4	86~100°C	81~90°C	81~90°C	91~106°C	96~111°C
	3	71~85°C	71~80°C	71~80°C	76~90°C	81~95°C
	2	56~70°C	61~70°C	61~70°C	56~75°C	61~80°C
	1	41~55°C	41~60°C	41~60°C	36~55°C	41~60°C
BLUE (Bottom)	3	21~40°C	21~40°C	21~40°C	16~35°C	21~40°C
	2	1~20°C	1~20°C	1~20°C	1~15°C	1~20°C
	1	~0°C	~0°C	~0°C	~0°C	~0°C

### 3-4 Fuel Level Indicator (diesel and gasoline models)

Accurately displays the remaining fuel for trucks using diesel or gasoline.

If using LPG, only the FULL (blue) and EMPTY (red) levels are indicated. When the low fuel icon begins flashing, the truck must be immediately parked and the fuel tank renewed before the engine shuts down.

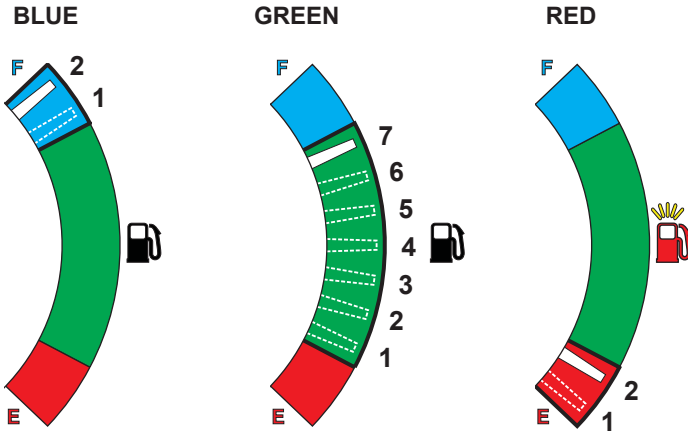

#### 3-Zone specification

Zone	Gauge Step	Level
BLUE (Top)	2	91 ~ 100 %
	1	81 ~ 90 %
GREEN (Middle)	7	71 ~ 80 %
	6	61 ~ 70 %
	5	51 ~ 60 %
	4	41 ~ 50 %
	3	31 ~ 40 %
	2	21 ~ 30 %
	1	11 ~ 20 %
RED (Bottom) *ICON Flashing	2	6 ~ 10 %
	1	0 ~ 5 %



### Speed Meter

Show truck speed. (Unit : km/h or MPH)

**15.9** km/h

### Time Indicator

Show current hour.

30 / MAR / 2017  
AM  
**09:00**

### Hour Meter or Trip Distance Indicator

Show truck operating hours or distance.

Trip distance must be configured with MENU setting for km and miles.

#### Hour Meter

 **12345.6** HR

#### Trip Distance

**12345.6** km

### Direction Indicator

**Standard** = Show travel direction.



Forward



Neutral



Reverse

### Warning Symbol and Lamp Status Indicator

ICON lights displayed for recognition when errors or issues occur.

### Parking Brake Icon

Indicates that the parking brake is engaged.

The parking brake is automatically applied and released but can also be activated in an emergency by pressing the button below the steering wheel.

**(P)**

## Seat Warning / Seat Belt Warning (optional)

The icon lights up when the driver does not sit on the seat.

This also optionally functions as a seat belt reminder. If the seat belt is not worn, it will illuminate.



## Fault Icon

When an error occurs this icon is displayed to distinguish the condition easily. When the error message is displayed, this icon is simultaneously displayed.



## Work Light Icon

There are two ways to turn ON/OFF the work light.

1. The work light is activated using the button.  
Push the work light button to turn the light ON .  
Push it again to turn the light OFF.



2. The work light is activated using the key switch. (when set in the menu)  
By turning the key switch to the "ON" position, the work light is automatically activated.  
By turning the key switch to the "OFF" position, the work light is deactivated.

## NOTICE

**If the operator turns the switch OFF, the lights will be turned OFF automatically after 5 seconds.**

### Rear Work Light Icon

There are three ways to turn ON/OFF the rear work light.

1. The rear work light is activated using the button.  
Push the rear work light button to turn the light ON.  
Push it again to turn the light OFF.
2. The rear work light is activated using the key switch. (when set in the menu)  
By turning the key switch to the “ON” position, the rear work light is automatically activated.  
By turning the key switch to the “OFF” position, the rear work light is deactivated.
3. The rear work light is activated when the directional lever is placed in reverse and then deactivated when it is moved out of reverse.

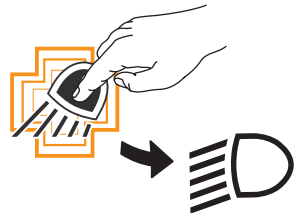

**If the operator turns the switch OFF, the lights will be turned OFF automatically after 5 seconds.**

### Strobe Light Icon

There are two ways to turn ON/OFF the strobe light.

1. The strobe light is activated using the button.  
Push the strobe light button to turn the light ON.  
Push it again to turn the light OFF.
2. The strobe light is activated using the key switch. (when set in the menu)  
By turning the key switch to the “ON” position, the strobe light is automatically activated.  
By turning the key switch to the “OFF” position, the strobe light is deactivated.

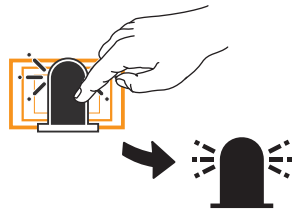

## Coolant Over Temp Warning Lamp

If the temperature of coolant is excessively high, and the gauge enters the red zone, this warning lamp turns on. Operation is switched to engine shutdown mode if the temperature exceeds the specified max. temperature.



## Transmission Oil Temperature Warning Lamp

Indicates that the transmission oil temperature is excessive.

If the light is on, shut down the truck and service it.

The truck will display a pre-shutdown warning followed by shut down mode if the temperature does not drop.



## Engine Oil Pressures Warning Lamp

Indicates engine oil pressure is too low. If the light is on, shut down the truck and service it.

The truck will go into shut down mode after the light flashes for 30 seconds.(the buzzer sounds)



## Maintenance Warning Lamp

LED will illuminate as truck approaches preset service time and when service time is reached. When LED is on, the preset service time is approaching or has been reached, indicating that a PM(Planned Maintenance) is required. For service contact your responsible CLARK dealer.



## Battery Charging Warning Lamp

This symptom indicates trouble on the batteries or improper charging of the batteries by the alternator. If the charging warning lamp turns on while the engine is running, the system should be serviced for proper charging.



### Engine Check Lamp

When the engine has problem, this LED will be on. Contact your CLARK dealer.

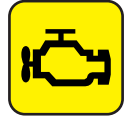

### Glow Plug Preheat (*Diesel Truck*)

Turn the starter key to "ON" position.

The indicator light will illuminate indicating that an electrical operated glow wire is heating the air in the induction manifold. After the light goes out, you may start the engine. If the engine fails to start, turn the key switch to "ON" and wait for 30 seconds before turning it to start.



### Smart Interlock Icon (optional)

Operating sitting on the seat shall wear the seat belt.

See page 3-37 for further information.



### Speed Limit Function Icon (optional)

The icon indicates that the max. speed limit function of the forklift truck is activated.

You can set ON/OFF and limit speed on the service menu mode. A password is required, contact your dealer.

- Setup path: Service Menu Mode, SETUP → SPEED SETUP



## Weight Indicator (optional)

Weight of load is measured and indicated on the display.

The default unit of weight on the service menu mode is "kg." You can set the unit to pound (lb) on the menu when measuring load weight. A password is required, contact your dealer.



- Setup path: Service Menu Mode, SETUP → LOAD WEIGHT

The weight displayed is not valid for legal trade. See page 3-22 (3) for further information of setup.

## 4. Display Monitoring

### Driver menu mode parameter configuration Description

Press M Button. Go into Driver MENU without Password.

Num	Parameters	Min	Max	Base	Unit
S	SETUP				
S1	CLOCK SETUP				
S1.1	CLOCK SETUP	24h	AM	0	Hrs
S2	TRIP RESET				
S2.1	TRIP DISTANCE RESET				
S2.2	TRIP HOUR RESET				
S3	WEIGHT SET TO ZERO				
S3.1	WEIGHT SET TO ZERO				
S4	LAMP CONTROL SETUP				
S4.1	WORK LIGHT	SWITCH	KEY	SWITCH	
S4.2	REAR WORK LIGHT	SWITCH	KEY	SWITCH	
M	MONITOR				
M1	STATUS				
M1.1	BATTERY VOLTAGE	0.0	30.0	Actual	V
M1.2	FUEL LEVEL	0	100	Actual	%
M1.3	ENGINE SPEED	0	8031	Actual	rpm
M1.4	ENGINE COOLANT TEMPERATURE	-40	150	Actual	°C

### Section 3. Operator Compartment and Controls

Num	Parameters	Min	Max	Base	Unit
M1.5	ENGINE OIL PRESSURE	0	1000	Actual	kpa
M1.6	ACCELERATOR PEDAL POSITION	0	100	Actual	%
M1.7	FUEL EFFICIENCY	0	3,212.8	Actual	L/h
M1.8	TRIP DISTANCE	0	99,999.9	Actual	km/h
M1.9	TRIP HOUR	0	99,999.9	Actual	hr
M1.10	TOTAL DISTANCE	0	99,999.9	Actual	km/h
M2	INPUTS				
M2.1	START SWITCH	OPEN	CLOSE	Actual	
M2.2	FORWARD SWITCH	OPEN	CLOSE	Actual	
M2.3	NEUTRAL SWITCH	OPEN	CLOSE	Actual	
M2.4	REVERSE SWITCH	OPEN	CLOSE	Actual	
M2.5	SEAT SWITCH	OPEN	CLOSE	Actual	
M2.6	T/M OIL TEMPERATURE SWITCH	OPEN	CLOSE	Actual	
M2.7	ENGINE OIL PRESSURE SWITCH	OPEN	CLOSE	Actual	
M2.8	LPG PRESSURE SWITCH	OPEN	CLOSE	Actual	
M2.9	ENGINE SERVICE	OPEN	CLOSE	Actual	
M2.10	TILT LIMIT SWITCH	OPEN	CLOSE	Actual	
M2.11	PARKING BRAKE SWITCH	OPEN	CLOSE	Actual	
M2.12	WINDOW DEFOGGER SWITCH	OPEN	CLOSE	Actual	
M2.13	OPTION SWITCH	OPEN	CLOSE	Actual	
M2.14	IVS SWITCH	OPEN	CLOSE	Actual	
M2.15	BRAKE SWITCH	OPEN	CLOSE	Actual	
M2.16	SEAT BELT SWITCH	OPEN	CLOSE	Actual	
M2.17	PARKING BR ENG SW	OPEN	CLOSE	Actual	
M2.18	FUEL SELECT	D/G	LPG	Actual	
M2.19	FREE LIFT SWITCH	OPEN	CLOSE	Actual	
M3	OUTPUTS				
M3.1	ENGINE SHUTDOWN RELAY	OFF	ON	Actual	
M3.2	HORN RELAY	OFF	ON	Actual	

Num	Parameters	Min	Max	Base	Unit
M3.3	WINDOW DEFOGGER RELAY	OFF	ON	Actual	
M3.4	START SIGNAL	OFF	ON	Actual	
M3.5	TRAVEL ALARM	OFF	ON	Actual	
M3.6	FORWARD SOLENOID	OFF	ON	Actual	
M3.7	REVERSE SOLENOID	OFF	ON	Actual	
M3.8	PARKING SOLENOID	OFF	ON	Actual	
M3.9	WORK LIGHT	OFF	ON	Actual	
M3.10	REAR WORK LIGHT	OFF	ON	Actual	
M3.11	STROBE LIGHT & BLUE DOT LIGHT	OFF	ON	Actual	
M3.12	OPTION	OFF	ON	Actual	
<b>L</b>	<b>ALARM LOGBOOK</b>				
L1	ENGINE ERROR				
L1.1	ACTIVE ERROR				
L1.1.1	ERROR1				
.....					
L1.1.10	ERROR10				
L1.2	HISTORIC ERROR				
L1.2.1	ERROR1				
.....					
L1.2.10	ERROR10				
L1.3	CLEAR HISTORIC ERROR	NO	YES		
L2	T-CON. ERROR				
L2.1	ACTIVE ERROR				
L2.1.1	ERROR1				
.....					
L2.1.10	ERROR10				
L2.2	HISTORIC ERROR				
L2.2.1	ERROR1				
.....					
L2.1.10	ERROR10				
L2.2	HISTORIC ERROR				



Num	Parameters	Min	Max	Base	Unit
L2.2.1	ERROR1				
.....					
L2.2.10	ERROR10				
L2.3	CLEAR HISTORIC ERROR	NO	YES		
L3	SPEED LIMIT ERROR				
L3.1	ACTIVE ERROR				
L3.1.1	ERROR1				
.....					
L3.1.10	ERROR10				
L3.2	HISTORIC ERROR				
L3.2.1	ERROR1				
.....					
L3.2.10	ERROR10				
L3.3	CLEAR HISTORIC ERROR	NO	YES		
L4	EHL ERROR				
L4.1	ACTIVE ERROR				
L4.1.1	ERROR1				
.....					
L4.1.10	ERROR10				
L4.2	HISTORIC ERROR				
L4.2.1	ERROR1				
.....					
L4.2.10	ERROR10				
L4.3	CLEAR HISTORIC ERROR	NO	YES		
U	DEVICE INFORMATION				
U1	DISPLAY				
U1.1	SOFTWARE VERSION				
U1.2	SERIAL NUMBER				
U2	TRUCK CONTROLLER				
U2.1	SOFTWARE VERSION				
U2.2	SERIAL NUMBER				
U3	SPEED CONTROLLER				
U3.1	SOFTWARE VERSION				

Num	Parameters	Min	Max	Base	Unit
U3.2	SERIAL NUMBER				
U4	EHL CONTROLLER				
U4.1	SOFTWARE VERSION				
U4.2	SERIAL NUMBER				

### Menu Mode - Monitor Description

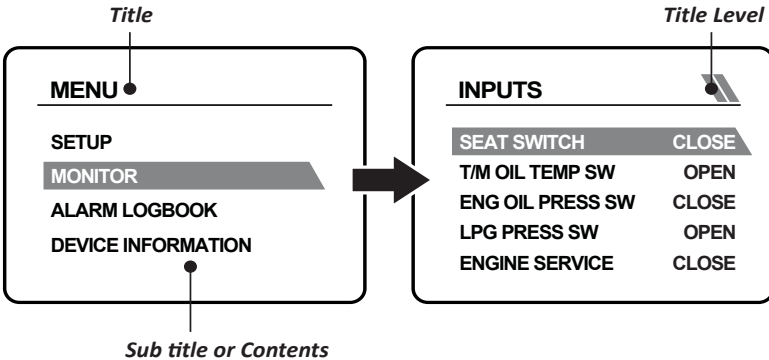

### (1) How to display Driver menu mode, and Service menu mode

1. Pressing the Mode button displays the Menu mode without entering the password.
2. Pressing the Enter button opens the password window, and the Service Menu mode is displayed when the correct password is entered.
3. When you enter correct password, "PASSWORD OK" message is displayed, and the buzzer sounds.
4. When you enter wrong password, "PASSWORD ERROR" message is displayed, the buzzer sounds, and Password Input screen is prompted again.

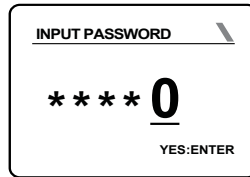
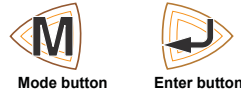

**(2) How to enter service menu mode if you forget the password**

1. Press UP/DOWN buttons on the basic main screen simultaneously for two seconds.
2. 8-digit Ref. No. 1, and 8-digit No. 2 are displayed as shown on the right figure.
3. Contact your dealer or CLARK Service Center with the numbers.

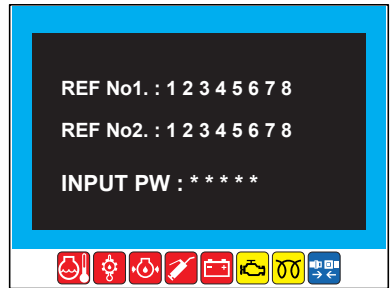
**Driver Menu Mode**

The driver menu mode is configured as follows:

- Clock setup
- Trip distance reset
- Zero setting of load weight
- Forklift truck condition monitoring (When setting ON in the service menu mode)
- Alarm logbook (When setting ON in the service menu mode)

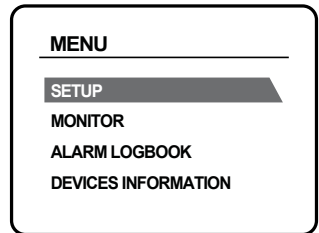
**(1) Date and Time Setting menu**

Current date and time are set.

Switching between 12- and 24-hour systems and between AM and PM is allowed.

- Make use of Plus (+) and Minus (-) buttons to change the current values.
- Make use of the down arrow button to move to the next value, and the up arrow button to move to the previous value.
- Pressing Enter button saves the value and moves to the previous menu.

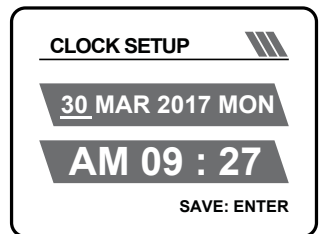

- Pressing Mode button does not save the value, and moves to the previous menu.
- Setup path: Driver Menu Mode, SETUP → CLOCK SETUP

## (2) Reset Menu of Trip Hour Meter or Trip Distance

When the forklift truck operates at speed higher than 0.5 km/h, 'Trip Hour Meter or Trip Distance' is displayed; when the truck operates at speed of 0.5 km/h or lower or stops, 'Whole Hour Meter or Trip Distance' is displayed.

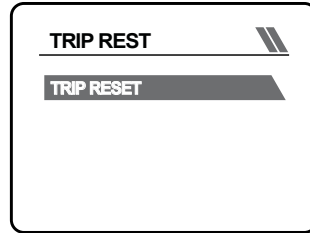

The current hour meter or trip distance can be reset to "0" on the menu.

- Move to "SETUP" menu on the menu mode.
- Move to "TRIP RESET" menu on "SETUP" menu.
- Pressing Enter button on "Trip Reset" parameters in "TRIP RESET" menu resets the values.
- Pressing Mode button returns to the previous menu without saving value.
- Setup path: Driver Menu Mode, SETUP → TRIP RESET

### NOTICE

**The whole hour and Trip distance can increase but not decrease in the Service menu. Neither is changing 99999.9 to 00000.0 allowed.**

## (3) Menu for Resetting Load Weight to '0'

Operator can reset the default of the load weight gauge to "0" when operator directly changes attachment.

- Move to "Setup" menu on the menu mode.

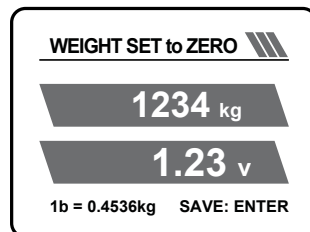

- Pressing Enter button on "Weight Set to Zero" menu on "Setup" menu resets the value to "0."
- Pressing Mode button returns to the previous menu without saving value.
- Setup path: Driver Menu Mode, SETUP → WEIGHT SET to ZERO



**WARNING**

**When the default is not reset to zero after changing the attachment, actual value of load weight may be different from measurement value.**

**(4) Monitor, Alarm Logbook Menu**

When setting Monitor menu and Alarm Logbook Menu to "ON" in service menu mode, the menus can be viewed in driver menu mode. If setting those menus to "OFF," they are not viewed in driver menu mode. A password is required, contact your dealer.

INPUTS	
SEAT SWITCH	CLOSE
T/M OIL TEMP SW	OPEN
ENG OIL PRESS SW	CLOSE
LPG PRESS SW	OPEN
ENGINE SERVICE	CLOSE

Each parameter displays five state values. Pressing Up/Down buttons, the values are displayed upward and downward.

- Setup path: Service Menu Mode, MONITOR → INPUTS

**(5) Error code**

In the drive menu mode, only error codes are displayed, and error codes can be deleted.

In the service menu mode, you can delete error codes after entering the password. Contact your dealer, regarding your password.

## Alarm Setup

Alarm can be set in service menu mode only. (Not set on the driver menu mode) A password is required, contact your dealer.

- Setup path: Service Menu Mode, SETUP → ALARM CONTROL

### (1) Seat (Driver's seat) Warning Setup

Used to set alarm when the seat switch is kept turned off for two seconds or longer during operation.

- Function of displaying message only / Message displaying + buzzer sounding function / Message displaying + horn sounding function

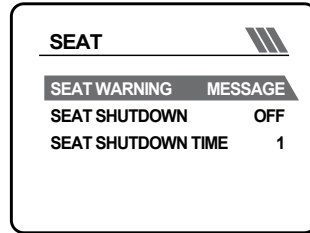

### NOTICE

See page 3-37 "Seat Warning" for further information.

### (2) Seat Shutdown Setup

When the seat switch is OFF for a period longer than Seat Shutdown Time setting while the engine is running, a function for stopping the engine can be set.

- OFF function / Function of displaying message only / Message displaying + buzzer sounding function / Message displaying + horn sounding function

### (3) Seat Shutdown Time Setup

When the seat switch is OFF for a period longer than this setting while the engine is running, the engine stops preventing fuel consumption. The value can be set between one and ten minutes.

### (4) Seat belt alarm setup

Used to set the seat belt warning function.

- Function of displaying message only / Message displaying + buzzer sounding function / Message displaying + horn sounding function

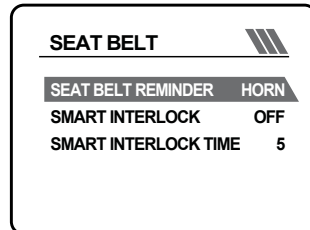

**NOTICE**

See page 3-37 "Seat Belt Warning" for further information.

**(5) Smart Interlock Setup (optional)**

Used to set the smart interlock function.

- OFF function / Function of displaying message only / Message displaying + buzzer sounding function / Message displaying + horn sounding function

**(6) Smart Interlock Time Setup**

When the hours set on the smart interlock setup conditions have elapsed, the buzzer sounds.

- Select and set value from "0, 5, 10, and 20 seconds."

**(7) Engine Shutdown Setup**

Used to set the engine shutdown function. When the engine is shutdown all lights are turned off.

- OFF function / Buzzer sounding function / Horn sounding function / Shutdown

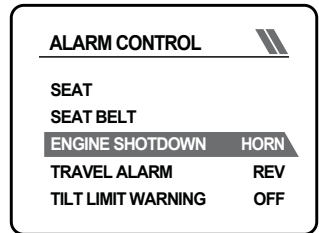
**(8) Traveling alarm setup**

Used to set the traveling alarm function.

- OFF function / Forward alarm / Backward alarm / Forward & backward alarm

**(9) Tilt Limit Warning Setup (only Korea option)**

Used to set the mast tilt angle limit alarm.

- ON function / OFF function

## Lamp Setup

- Setup path: Service Menu Mode, SETUP → LIGHT CONTROL

### (1) Front or Rear Work Lamp Setup

Used to set operation of the front and the rear work lamps. A password is required, contact your dealer.

- Key setting: Lamp is turned on when operating the key switch.
- Button setting: Lamp is turned on when operating the mode selection button on the instrument panel.
- Reverse Setting: Rear Work Lamp only, activated when directional lever placed in reverse.

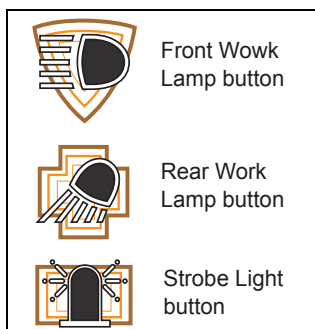

### (2) Strobe Light Setup

Used to set operation of the strobe light. A password is required, contact your dealer.

- Key setting: Lamp is turned on when operating the key switch.
- Button setting: Lamp is turned on when operating the mode selection button on the instrument panel.

### (3) Light Auto Timer

When the Seat switch opens during key-on (engine stopped) with Function setup turned on, lamps are automatically turned off when the set time has elapsed. A password is required, contact your dealer.

- OFF/Setting up to 10 minutes by one-minute increment



## Display Setup

Used to set options relevant to operation of the forklift truck.

A password is required, contact your dealer.

- Selecting operation hours and mileage
- Selecting display language (23 different languages)
- Setting vendor contact information marking
- Speed display ON/OFF

DISPLAY SETUP	
DISPLAY MODE	HOUR
LANGUAGE	ENG
DRIVER MONITOR	OFF
DRIVER ALARMLOG	OFF
DEALER INFORMATION	OFF

### (1) Truck mode setup

To reduce fuel consumption.

- OFF : ECO lamp off
- Standard mode : Activating ECO lamp(Only Ford engine)
- Economic mode
- Power mode



## Hour Setup

Used to set operation hours and maintenance hours of the forklift truck. A password is required, contact your dealer.

- Setup path: Service Menu Mode, SETUP → HOUR SETUP

HOUR SETUP	
OPERATING HOUR	12345.6
KEY ON HOUR	12345.6
ENGINE HOUR	12345.6
MAINTNANCE TIME	500

### (1) Operating hour

Operation hours are set based on the engine operation of the forklift truck.

## (2) KEY ON hour

Setting key On hours of the forklift truck.  
A password is required, contact your dealer.

## (3) Setting total operation hours

### NOTICE

**Make use of Plus (+) buttons to increase the values. (Pressing the button for one seconds or longer rapidly increases the value.) 99999.9 is the max. value, and it is not allowed to change 99999.9 to 00000.0.**



## (4) System time setting (not allowed to change)

Time information from the engine ECU is displayed on the instrument panel. Setting and change of the information are not allowed.

## (5) Setting maintenance hours

Setting maintenance hours of the forklift truck. A password is required, contact your dealer.

- You can set the maintenance hours between 0 and 3000 hours. Setup hour unit is 50 hours, and setup hours can be changed with Plus (+) and Minus (-) buttons. (OFF, 50, 100, ..... resetting)
- When maintenance hours are set, remaining hours until maintenance are displayed on the instrument panel until maintenance hours are reached. If specified maintenance hours are exceeded, such exceeded hours are displayed on the instrument panel. Such exceeded hours are displayed until reset.

## Password Setup

Password setting is allowed only in the Service menu, and operation is allowed in the Driver menu without entering the password.

- Setup path: Service Menu Mode, SETUP → PASSWORD SETUP

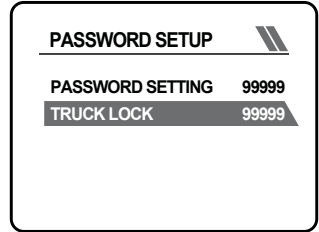

### (1) Password Locking

Used to set the locking function of the forklift truck. When the forklift truck locking function is set, the main screen is not displayed even upon "KEY ON," locking of the forklift truck is indicated, and the password input screen is prompted.

- If you do not enter the password, the buzzer sounds once every five seconds.
- When entering correct password, "PASSWORD OK" message is displayed, the buzzer sounds once, and then the main screen is displayed.
- When you enter wrong password, "PASSWORD ERROR" message is displayed, the buzzer sounds once, and Password Input screen is prompted again.

### Speed Limit Setup (optional)

Turtle icon is displayed together with the speed setting. (Km/h or MPH)

Turtle Icon button is not capable of turning the speed limit function on or off.

- Setup path: Service Menu Mode, SETUP → SPEED SETUP

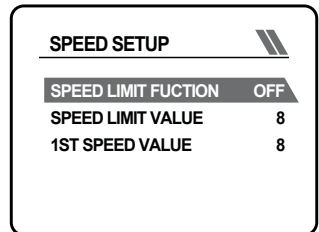

### (1) Speed Limit Function Setup

*(for the forklift trucks mounted with Isuzu,PSI,Ford,HMC engines)*

Used to set the speed limiting function of the forklift truck below speed setting to ON or OFF. A password is required, contact your dealer.

## (2) Speed Limit Value Setup

*(for the forklift trucks mounted with Isuzu,PSI,Ford,HMC engines)*



Used to set the speed limit of the forklift truck. A password is required, contact your dealer.

## Weight Function Setup

- Setup path: Service Menu Mode, SETUP → LOAD WEIGHT

### (1) Display Function ON/OFF

You can set the weight function to ON or OFF. The value is displayed in 'kg' or 'lbs' upon unit setting.

LOAD WEIGHT	
WEIGHT FUCTION	OFF
LOAD WEIGHT	1234
LOAD WEIGHT SENSOR	1
OFFSET WEIGHT	1
REFERENCE LOAD	1

Used to display the default value, and change the value with Plus (+) and Minus (-) buttons. Pressing Enter button saves changed value, sounds the buzzer, and displays changed values. When you desire to move to

the superordinate menu without saving changed value, use Menu button. A password is required, contact your dealer.

### (2) Weight indication

Weight is displayed. The value is displayed in kg or lbs depending upon unit setting. Changing the value in the driver menu mode is not possible. A password is required, contact your dealer.

### (3) Weight value indication

Weight value (sensor value) is displayed. Changing the value in the driver menu mode is not possible. A password is required, contact your dealer.

**(4) Weight resetting****(Allowed setting when the weight function set to 'ON')**

Actual initial load value is reset to zero. When operator mounts or changes attachment upon his/her discretion, actual value after mounting attachment can be reset to '0 kg.' A password is required, contact your dealer.

**(5) Max. Load Setup**

Max. load is set. (Setup range: 0-20,000 kg by increment of 1 kg) A password is required, contact your dealer.

**Rear Camera Function Setup (optional)**

You can set the rear camera function to ON or OFF. A password is required, contact your dealer.

Images transmitted from the rear camera are displayed on the instrument panel only when the gear lever is shifted to the forward position while the camera is kept turned on.

- Setup path: Service Menu Mode, SETUP → REAR CAMERA

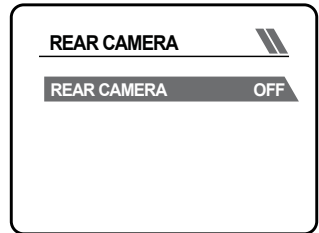
**Auto Parking Setup**

The parking brake applies whenever the truck is turned off or the operator leaves the seat. While traveling, if the operator leaves the seat or unlatches the seatbelt (Smart Interlock only), the transmission will first shift into neutral and then the parking brake applies. The parking brake can also be manually applied by pressing the parking brake switch on the steering column.

The parking brake is released when the service brake pedal is depressed and then the desired travel direction is selected. Using the dash display, the parking brake release function can be changed so that it occurs when the desired travel direction is selected and then the accelerator pedal is depressed. For earlier trucks, the parking brake is released when the travel direction is changed while the truck is stopped.

A password is required to change the parking brake functions using the dash display, contact your dealer for assistance.

- Setup path: Service Menu Mode,

SETUP → AUTO PARKING



## CAUTION

**Always make sure that the parking brake is functioning correctly before leaving the truck.**

### (1) Anti Roll Back (OFF by default)

*(for the forklift trucks mounted with Suzuki, PSI, Ford, HMC engines)*

Auto parking brake applying function is set for preventing slipping of the forklift truck while traveling on gradient. (This function is not available on Yanmar engine because the engine has no ECU.)

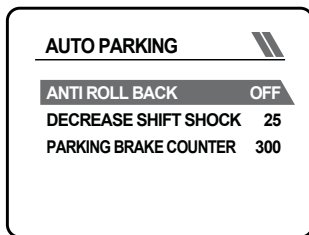

- The parking brake applies when speed is reduced to 0 km/h, when releasing the accelerator and pushing the brake pedal while the forklift truck is on a gradient of 7% or more.

### (2) Decrease Shift Shock

Delays transmission direction change shift until set speed. This is to reduce impact on the drive-line that occurs during rapid reverse to forward (and vice-versa) shifting. (The default is 25 km/h.)

- The setting can be changed between 1 and 25 km/h in increments of 1 km/h.
- Example: When the fork truck travels forward at speed of 10 km/h with a setting of 8 km/h, and the direction lever is shifted from forward to reverse direction, the speed of the truck is reduced to 8 km/h before the direction change shift occurs.

## Error Codes

Errors of individual controller are displayed.

Once an error takes place, specifics of the error are displayed as shown on the figure to the right.

Check the specifics of error by pressing Minus (-) button on the right of the instrument panel as follows :



- Setup path:  
Driver Menu Mode (or Service Menu Mode), ALARM LOGBOOK

### (1) Checking error on engine

If an engine error takes place on the forklift truck, "Engine Fault Warning Lamp" is displayed on the main screen, and error message is shown.

The screen displays two or three errors. Pressing Mode button displays the menu mode. If there is no error, a submenu is not displayed.

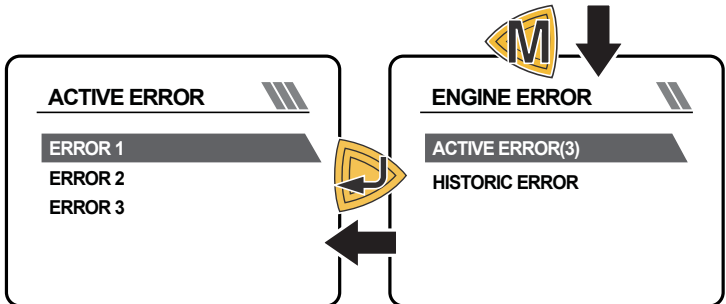
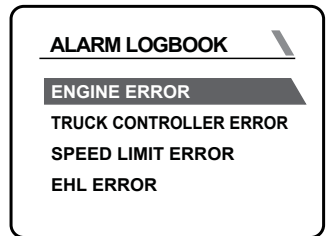

It is possible to check error history from Parameter, "HISTORIC ERROR."

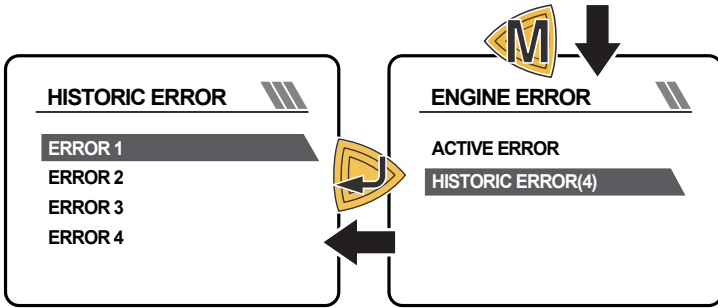

The specifics of an error are shown as the right to the figure.

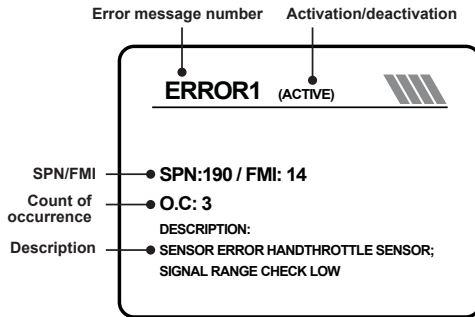

## (2) Truck controller error

If an error takes place on the forklift truck, "Fault Icon" is turned on the main screen, and error message is displayed.

Pressing "Down Arrow" on the right of the instrument panel displays error codes in sequence. Pressing Mode button displays the menu mode. If there is no error, a submenu is not displayed.

See "Checking Engine Error" on the previous page for activated error codes and specifics of errors.

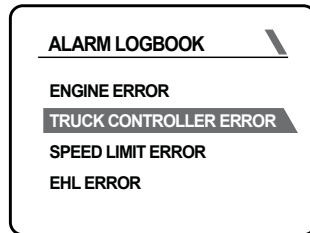
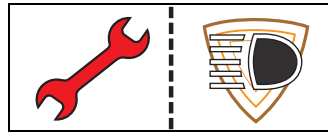



### (3) Mini-Lever controller error (optional)

If an error takes place on the forklift truck, "Fault Icon" is turned on the main screen, and error message is displayed.

Pressing "Down Arrow" on the right of the instrument panel displays error codes in sequence. Pressing Mode button displays the menu mode. If there is no error, any submenu is not displayed.

See "Checking Engine Error" on the previous page for activated error codes and specifics of errors.

### (4) Speed Limit controller error

If an error takes place on the forklift truck, "Fault Icon" is turned on the main screen, and error message is displayed.

Pressing "Down Arrow" on the right of the instrument panel displays error codes in sequence. Pressing Mode button displays the menu mode. If there is no error, any submenu is not displayed.

See "Checking Engine Error" on the previous page for activated error codes and specifics of errors.

### (5) Parking Brake Counter

Applications of the parking brake at forklift truck speeds of 5 km/h or more are counted. These are recorded because using the brake in this manner is abuse of the parking brake.

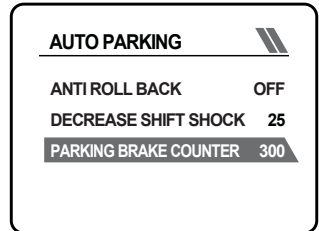

### Device Information

You can identify software versions and serial numbers of individual controllers.

- Setup path: Service Menu Mode, DEVICE INFORMATION

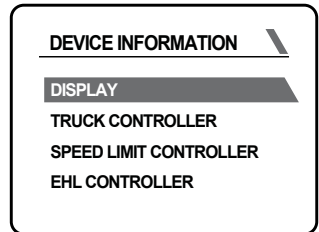

## Message Function

Below are frequent warning messages :  
Detailed descriptions on following pages.

	Warning Message(English)	Specifics of Warning
1	INCORRECT START PUT DIRECTIONAL LEVER IN NEUTRAL	Neutral position warning
2	SEAT SWITCH OPEN.	Seat warning
3	SEAT BELT SWITCH OPEN.	Seat belt warning
4	REFASTEN SEAT BELT	Smart interlock warning
5	NEXT MAINTENANCE IN	Maintenance hour warning
6	MAXIMUM TILT ACHIEVED	Tilt limit warning
7	ENGINE WILL SHUT DOWN AFTER 30 SECONDS.	Engine shutdown warning
8	ENGINE OIL PRESSURE WARNING	Engine oil pressure warning
9	ENGINE COOLANT TEMPERATURE WARNING	Engine coolant temperature warning
10	TRANSMISSION OIL TEMPERATURE WARNING	Transmission oil temperature warning
11	FUEL LEVEL LOW	Low level fuel warning
12	START INTERRUPTED	Key switch warning
13	CHECK ENGINE CONTROLLER	ECU communication warning
14	CHECK TRUCK CONTROLLER	Sub-controller communication warning
15	CHECK CAN BUS LINE	CAN communication warning
16	ENGINE RUNNING	Engine Warning
17	PASSWORD ERROR	Wrong password input

### Incorrect Start Put Directional Lever in Neutral

When starting the engine with the gear lever shifted to forward or backward position, warning message is displayed, and the buzzer sounds.

Engine starting is allowed only when the gear lever is in the neutral position.

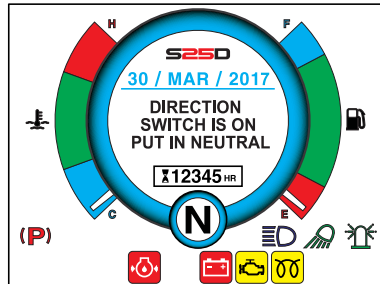

### Seat Switch Open

Warning takes place when operator leaves the driver's seat.

Warning message is displayed, "Seat Icon" blinks, and the buzzer sounds.

Warning is removed when operator sits on the seat.

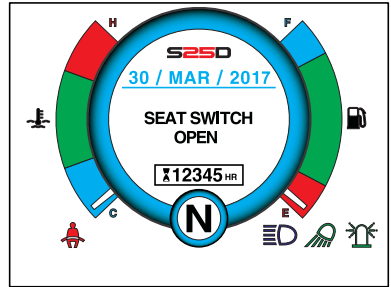

### Seat Belt Switch Open (optional)

Warning takes place when operator releases the seat belt with the gear lever shifted out of the neutral position.

Warning message is displayed, "Seat Icon and Seat belt Icon" blink, and the buzzer sounds three times.

The warning is removed immediately when operator wears seat belt.

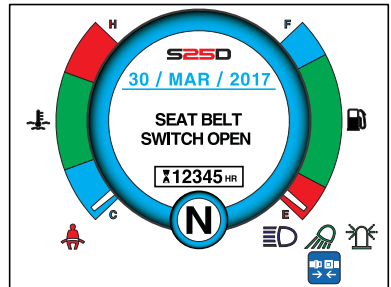

### Refasten Seat Belt Smart Interlock (optional)

Warning message is displayed, "Seat Icon and Seat belt Icon" blink, and the buzzer sounds three times.

#### (1) When the smart interlock function is turned on;

1. The key switch is turned on. (KEY ON)
2. Operator sits on the seat. (Seat switch ON)

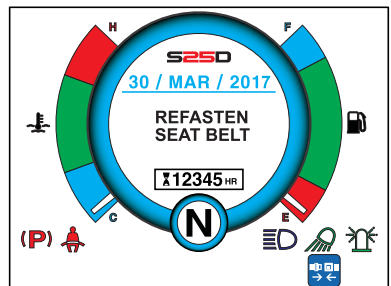

3. Operator wears the seatbelt. (Seat belt ON)
4. The forklift truck normally operates only when step 1 to 3 above are completed in sequence.

### (2) When smart interlock warning takes place:

- Warning takes place when seat belt is latched before operator is in seat.

### (3) Operation of the smart interlock during operation

Smart Interlock	Speed	Seat Switch	Seatbelt Switch	Smart Interlock Time Setup	Truck status
OFF	3km/h or lower	When OFF for 2 sec or longer	When OFF for 0.5 sec or longer	-	<b>A</b>
	over 3km/h			-	<b>B</b>
ON	3km/h or lower			a	<b>C</b>
	over 3km/h			a	<b>D</b>

Truck status	Description of operation	Remark
<b>A</b>	1) Warning displayed 2) Trans shifts into neutral 3) Delay time: 1 sec 4) Auto parking brake applied	
<b>B</b>	1) Warning displayed 2) Trans shifts into neutral 3) Delay time: 5 sec 4) Auto parking brake applied	Pressing the parking brake switch at 5 km/h (3 mph) or more is counted.
<b>C</b>	1) Warning displayed 2) Setup time: a sec. 3) Trans shifts into neutral 4) Delay time: 1 sec 5) Auto parking brake applied	a: 0, 5, 10, 15, 20 sec
<b>D</b>	1) Warning displayed 2) Setup time: a sec 3) Trans shifts into neutral 4) Delay time: 5 sec 5) Auto parking brake applied	a: 0, 5, 10, 15, 20 sec Pressing the parking brake switch at 5 km/h (3 mph) or more is counted.

**CAUTION**

When pressing Parking Switch during operation, the parking brake immediately applies.

**Next Maintenance In:**

When setting maintenance hours on "Hour Setup" in page 3-27, remainder maintenance hours are displayed when turning the key on if defined maintenance hours are not exhausted.

When defined maintenance hours are exhausted, hours exceeding the maintenance hours are displayed on the screen when turning the key on, and Maintenance Icon lights.

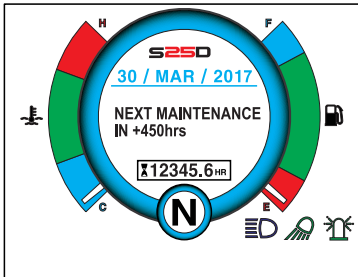
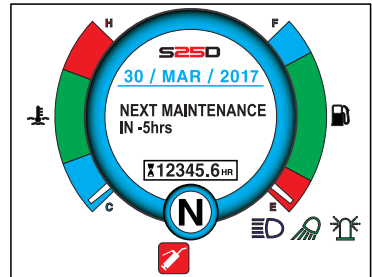
**Before exhausting defined maintenance hours****After exhausting defined maintenance hours****Maximum Tilt Achieved (only Korea option)**

When the mast inclines forward by 6 degrees or more, warning message is displayed, and the buzzer sounds.

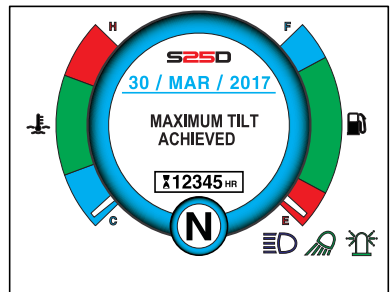

## Engine Will Shut Down After 30 Seconds

Shutdown of the engine is indicated. The engine stops 30 seconds after display of the engine shutdown warning alarm.

1. Popup window is prompted immediately after occurrence of the shutdown warning.
2. The forward / backward solenoid valves are released. (10 – 20 sec)
3. The engine is shut down and parking is automatically performed 30 seconds later.
4. Move the forklift truck to safe place before auto shutdown, and turn the engine off.

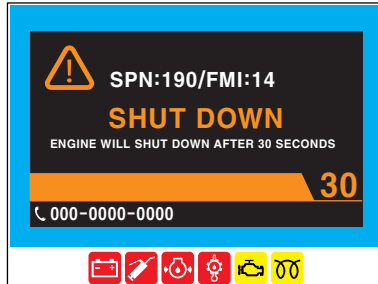

### NOTICE

**When the warning is reset during shutdown mode, shutdown mode aborted.**

## Engine Oil Pressure Low

Engine oil pressure warning.

### (1) Lamp turned on

If engine oil pressure error takes place, "Engine Oil Pressure Warning Lamp and Engine Failure Warning Lamp" icons are only turned on.

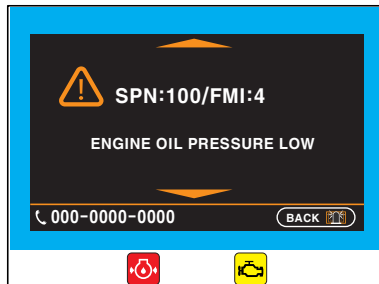

## (2) Warning occurred

- **Forklift truck with Yanmar engine**

When engine oil pressure error persists for 3 seconds or longer while the engine is running :

1. Error is detected from the operating engine.
2. Warning message popup window is prompted on the display, the buzzer sounds, and warning lamp is turned on.
3. If shutdown warning alarm is indicated on the display, move the forklift truck to safe place before auto shutdown, and turn the engine off.

- **Forklift truck with Isuzu, PSI, Ford, HMC engine**

When engine oil pressure error persists for 8 seconds or longer while the engine is running :

1. Error is detected from the operating engine.
2. Warning message popup window is prompted on the display, the buzzer sounds, and warning light is turned on.
3. The engine is switched to the deceleration mode to reduce rpm, power and torque, and error message is recorded.
4. If shutdown warning alarm is indicated on the display, move the forklift truck to safe place before auto shutdown, and turn the engine off.

## (3) Oil pressure drop warning during low level oil warning

1. Warning message popup window is prompted on the display.
2. If shutdown warning alarm is indicated on the display, move the forklift truck to safe place before auto shutdown, and turn the engine off.

## Engine Coolant Temperature High

Engine coolant temperature warning.

### (1) Lamp turned on

1. "Coolant Overheat Warning Lamp, and Engine Fault Warning Lamp" icons are turned on, and warning message is displayed.

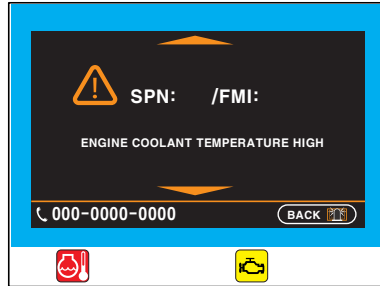

### (2) Warning occurred

1. "Coolant Overheat Warning Lamp, and Engine Fault Warning Lamp" icons are turned on, and warning message is displayed.
2. The forward and the backward solenoid valves are released 20 seconds later.
3. The engine is shut down, and the parking brake applies 30 seconds later.

### (3) The warning takes place also when coolant temperature does not vary for 10 minutes at 40°C or lower during engine operation.

1. "Coolant Overheat Warning Lamp, and Engine Fault Warning Lamp" icons are turned on, and warning message is displayed.
2. The forward and the backward solenoid valves are released 20 seconds later.
3. The engine is shut down, and the parking brake applies 30 seconds later.



## Transmission Oil Temperature High

Transmission oil temperature warning. When the transmission oil temperature switch closes for 1 second or longer:

### (1) Lamp turned on

1. "Transmission Oil Temperature Warning Lamp" icon is turned on, warning message is displayed, and the buzzer sounds.

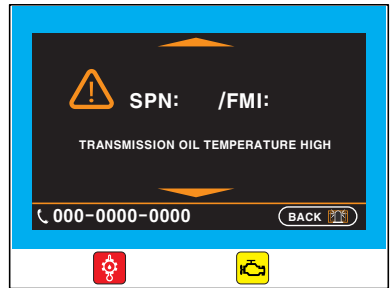

### (2) Warning occurred

1. If such situation(previous (1)) persists, the engine is switched to the idle mode.
2. If shutdown warning alarm is indicated on the display, move the forklift truck to safe place before auto shutdown, and turn the engine off.

## Low-Level Fuel Warning

Warning takes place, if fuel in the forklift truck is deficient.

When the fuel level gauges is on the red section:

1. LOW warning window is prompted if the gauge is in Zone 2 of the red section.
2. LOW warning window is prompted if the gauge is in Zone 1 of the red section, and the engine is shut down in several minutes.



## Starter Interrupted

To protect starter from overheating, when the key switch is kept turned to “Start” position for 15 seconds or longer, warning message is displayed and the buzzer sounds.

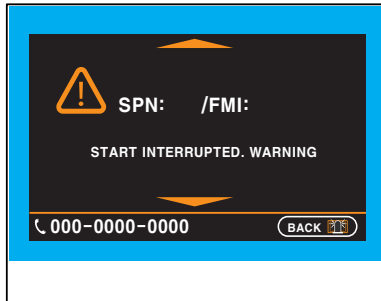

## Check Engine Controller

Malfunction on engine controller Check error log messages.

## Check Truck Controller

Malfunction on truck controller. Check error log messages.

## Check CAN Bus Line

Malfunction in the CAN-BUS system. Check error log messages.

## Engine Running

Key in Start Position While Engine Running

To protect starter and ring gear from damage, if the ignition switch is moved to the start position while the engine is running, ENGINE RUNNING message is displayed and the starter is not activated.

## Password Error

A wrong password is used.

## Operator Controls

### Key/Start Switch

The Key/Start Switch:

- Turns the truck electrical system on and off.
- Connects and tests the warning indicator lights.
- Connects the starter motor circuit when engine is to be started.

The Key/Start Switch has three positions.

When the key is in the vertical "OFF" position, all truck electrical circuits are off, and the key can be removed. From the "OFF" position, the key can be turned clockwise to the "START" position, where the starter motor is engaged and part of the truck electrical system is energized.

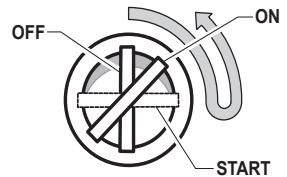

When the key is released from the "START" position, it automatically returns to the "ON" position, where the starter is disengaged and the entire truck electrical system is on.

### Cold Start Preheating (*Diesel Only*)

With the switch in the "ON" position the warning indicator will light up and the glow plugs pre-heat automatically. The engine can then be started. To repeat the preheating process turn the key to the "OFF" and then into the "ON" position.

### Engine Stop

Run the engine at idling speed briefly before shutting it off.

Turn the key switch to the "OFF" position to shut the engine down.

## Seat Adjustment

The fore and aft adjustment lever is located on the front under the seat. To unlock, pull the lever to the left and adjust the seat, release the lever. Be sure that the seat locking mechanism is engaged.

The back declining adjustment lever is located on the left side of seat cushion. Pull the lever up and adjust the back, release the lever. Be sure that the back locking mechanism is engaged.

The driver's weight adjustment knob is located on the front under the seat. To adjust, turn the knob to the left or right. The weight range is 50 kg~170 kg (110 lb~374 lb).

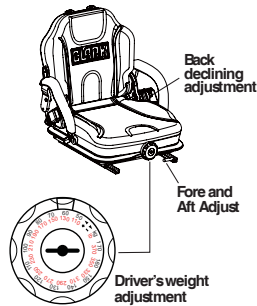

### CAUTION

**Never adjust driver's seat while truck is moving, to avoid the possibility of loss of control and of personal injury.**

## Parking Brake

The self-activating parking brake applies when the truck is turned off or when the operator leaves the seat. The parking brake will also apply automatically during certain functions such as Anti-Roll Back, Smart Interlock, etc.

Parking Brake Switch

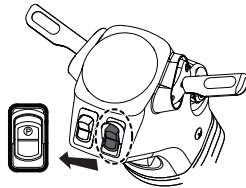

### CAUTION

**Do not attempt to leave a moving truck. Remain seated with the seatbelt latched until the truck comes to a complete stop and the parking brake icon is shown on the display.**

If an emergency occurs, such as failure of the service brakes, the operator can manually activate the parking brake by pressing the parking brake switch. Please know that frequent use of the parking brake while traveling is considered abuse and can damage the truck. Each occurrence of when the parking brake is used in this manner is recorded, which can be viewed using the display.

**CAUTION**

To manually release the parking brake when lift truck is disabled, refer to "How to Tow a Disabled Truck" on page 6-2.

**Hour Meter**

Starting the engine also starts the operating hour meter. Use the hour meter reading to perform prescribed maintenance.

**Steering System**

The steering handwheel operates a steering control valve that directs the oil flow to the steering cylinder connected to the steer axle. The steering control valve can also act as a pump to provide manual steering if the hydraulic pump stops.

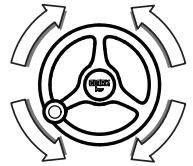
**Horn Button**

The horn button is located in the center hub of the steering handwheel. Depressing the button will sound the horn.

- **Note** : Separate horn buttons may be available as options, on the lift lever and/or rear handle.

**Brake Pedals**

The left brake pedal (inching pedal) has two functions in order to improve handling and efficiency. While pressing the inching pedal the first part of its movement interrupts the power from the engine to the transmission. The level of disengagement is dependent on the movement of the pedal. The last part of the travel applies the brake system. In this way you are able to lift a load rapidly with full engine RPM while controlling slow driving speed with the inching pedal like a clutch. This is very useful in confined working spaces.

On ramps or inclines the right brake pedal only should be used. When using the inching pedal on slopes the lift truck could move backwards or forwards unintentionally.

**Direction Control Lever**

This lever is typically on the left side of the steering column. When changing the direction of travel, make sure that your lift truck has come to a complete stop before moving the lever to the other position.



## CAUTION

If the truck will start with the direction control lever in either forward or reverse, there is a problem with the neutral start switch and it must be repaired.

## Traction Disable Function

When driver leaves the seat for over 3 seconds, the transmission goes to neutral (power of fwd/rev solenoids is shut off). When driver gets back in seat, truck will not go into gear until they shifts to neutral, then shifts into gear.

## Hydraulic Control Levers

The levers of the control valve activate the lift and tilt cylinders as well as other hydraulic devices which are installed on the truck.

### IMPORTANT

The hydraulic levers shown are typical representations of a CLARK internal combustion lift truck. Your model may vary slightly.

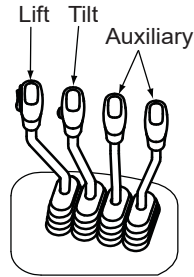

### 1) Lift Control Function

With the lift control lever, you are able to raise and lower the fork carriage on the upright. The lifting and lowering speeds are controlled through the main hydraulic valve by varying the lever position (from the center or neutral positions).

When the lift control lever is pushed forward, the fork carriage is lowered. When the lift control lever is pulled back the fork carriage is raised. You can also lower the fork carriage even if the key switch is ON position.

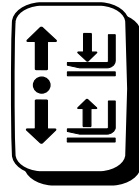

### 2) Tilt Control Lever

With the tilt control lever, you are able to control the tilting or vertical positioning of the upright and the angle of the forks. When the lever is pulled back, the upright and forks tilt backward. Push the lever forward to tilt the upright and forks forwards.

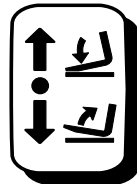

### 3) Auxiliary Control Lever (optional)

An auxiliary control lever is mounted to the right of the tilt control lever. If your lift truck is equipped with an optional attachment, this lever lets you control the flow and direction of the hydraulic oil to the attachment.

### 4) Control Function

1. Forward / Reverse Switch (optional)
2. Horn Button
3. Auxiliary Function (optional)
  - Vertical Mast Control Button
4. Auxiliary Function (optional)
  - Clamp Lever Lock Button (or Push Button)
5. Auxiliary Function (optional)
  - Clamp Lever Lock Button (or Push Button)

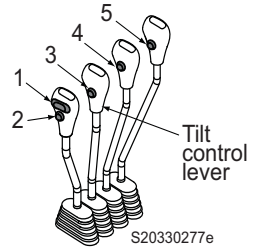

#### (1) Vertical Mast Control Function (optional)

When pressing this button, and operating the tilt control lever, the mast will stop when at vertical position (90 degrees).

#### (2) Clamp Lever Lock Function (optional)

When not pressing this button and pushing the lever, the clamp is not released.

When pressing this button and pushing the lever, the clamp is released.

## Mini Lever (optional)

### 1) Forward and Reverse switch

Switch for shifting between forward and reverse.

- **Forward** : Push forward
- **Reverse** : Push backward

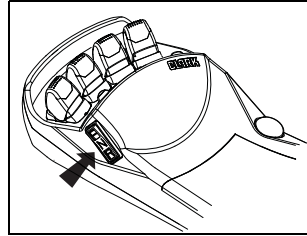

The speed of forward and backward traveling can be adjusted by pressing the accelerator pedal.

- Stop the vehicle before shifting between forward and backward traveling.
- Always operate the control switch from a properly seated position.

### 2) Lift Lever

Raise and lower the forks for loading.

- **Raise** : Pull backward
- **Lower** : Push forward

Raising speed can be adjusted by the extent of pulling the lift lever.

Lowering speed can be adjusted by the extent of pushing the lift lever.

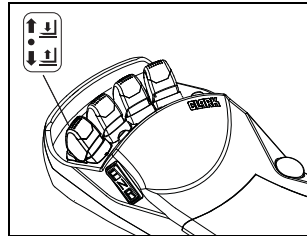

- If you leave the seat while lowering the lift lever, the forks will not descend due to the operators presence feature. This applies to all hydraulic functions.



### 3) Tilt Lever

Tilt the mast forward and backward.

- **Forward** : Push forward
- **Backward** : Pull backward

Forward or backward tilting speed can be adjusted by the extent of operating the lever.

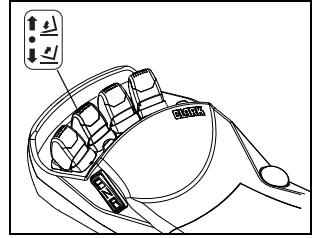

### 4) Attachment Lever

Operates the attachment.

Attachment speed can be adjusted by the extent of operating the lever.

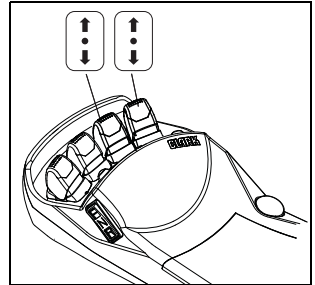

### 5) Emergency Disconnect

Activating this will disable all hydraulic functions. It must be pulled out to reset and re-enable hydraulic functions.

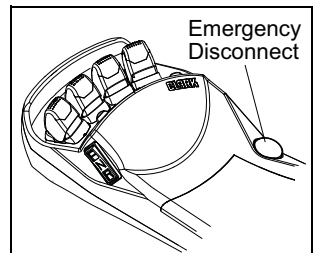

### 6) Attachment Button (optional)

- Vertical Mast (1)  
When pressing this button once, and operating the tilt lever, the mast stands perpendicular.
- Clamp lever lock (2)  
When pressing this button once, the clamp lever is locked two seconds later. Pressing the button again release the lever.

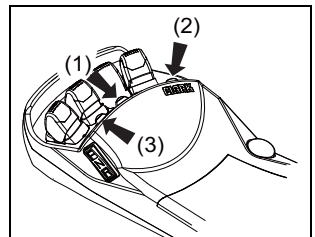

### 7) Horn Button (3)

## Steering Column

The steering wheel can be tilted forwards and backwards in small discrete movements. Pull and hold lock, move the wheel to the desired position and release lock.

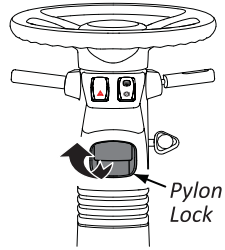

## Hood Open

The hood release lever is located on the left side of hood.

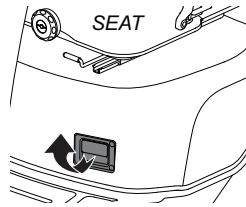

## Hood Close

Actuate release (red collar) on gas spring supporting hood and lower hood until latched.

### IMPORTANT

Ground speed is controlled by the accelerator pedal only.

For safety reasons, your CLARK forklift truck is fitted with a neutral start feature. The purpose of this is to prevent the engine from being started while the transmission is in gear. Thus the engine may only start when the direction control lever is in the neutral position.



### CAUTION

If the truck will start with the direction control in either forward or reverse, there is a problem with the neutral start switch and it must be repaired.

## Fuse

The fuses are located at the inside of the foot well, on the right when looking forward.

The fuse ratings are visible on the fuses.



### CAUTION

The fuse box lid contains the legend list of what the fuses are for and what their ratings are. Always replace fuses with the same current rating. Never put higher rated fuse in.

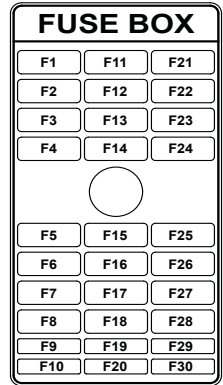

Fuse Specification			Truck Engine Type				
			ISUZU	YAN-MAR	FORD	PSI	HMC
F1	Sub Controller	10A	✓	✓	✓	✓	✓
F2	Sub Controller	10A	✓	✓	✓	✓	✓
F3	Parking	5A	✓	✓	✓	✓	✓
F4	Turn signal	10A	✓	✓	✓	✓	✓
F5	Horn	10A	✓	✓	✓	✓	✓
F6	Speed Limit Control	15A			✓		
	ECU B+	2A					✓
F7	Brake	5A	✓	✓	✓	✓	✓
F8	Power Jack	10A	✓	✓	✓	✓	
	Engine Shutdown	15A					✓
F9	Spare	10A	✓	✓	✓	✓	✓ (2A)
F10	Spare	30A	✓	✓	✓ (20A)	✓	✓ (7.5A)
F11	Fuel Pump	5A	✓	✓	✓	✓	
	Actuator	20A			✓		
	MPR 1 Relay	7.5A					✓
F12	ECM	30A	✓		✓ (10A)		
	Engine Shutdown	30A		✓			
	MPR 2 Relay	20A					✓
F13	Engine Shutdown	15A	✓		✓	✓	
	Power Jack	10A					✓
F14	Additional - Option Power	5A		✓	✓	✓	
	Telemertic	10A					✓

Fuse Specification			Truck Engine Type				
			ISUZU	YAN-MAR	FORD	PSI	HMC
F15	Room Lamp & Audio (option)	10A	✓	✓	✓	✓	
	Option	10A					✓
F16	Cabin - option (W/D)	20A	✓				
	Starter	20A			✓		
	Defogger (option)	20A		✓		✓	
	Option	20A					✓
F17	Heater/Aircon (option)	30A	✓	✓		✓	✓
	Option	20A			✓		
F18	Option	20A			✓		
	Speed Limit Control (Dual)	15A				✓	
	Option	30A					✓
F19	Spare	10A	✓	✓	✓	✓	✓
F20	Spare	5A	✓	✓	✓	✓	✓
F21	Direction Switch	10A	✓	✓	✓	✓	✓
F22	W/S Sensor	10A	✓	✓	✓	✓	✓
F23	Display	10A	✓	✓	✓	✓	✓
F24	Hyd Valve (ISO Relay)	10A	✓	✓	✓	✓	✓
F25	Aircon (option)	10A	✓				
	Option (vcc)	10A	✓				
	Power (option)	15A		✓	✓	✓	
	EHL (option)	15A			✓	✓	
	Option	20A					✓
F26	Heater	10A		✓	✓	✓	
	Wiper	10A					✓
F27	Wiper	15A	✓	✓	✓	✓	
	Speed Limit Control	10A					✓
F29	Spare - 15A	15A	✓	✓	✓	✓	✓
F30	Spare - 20A	20A	✓	✓	✓	✓	✓

## Heater and Air Conditioner (Optional)

### Lay-out

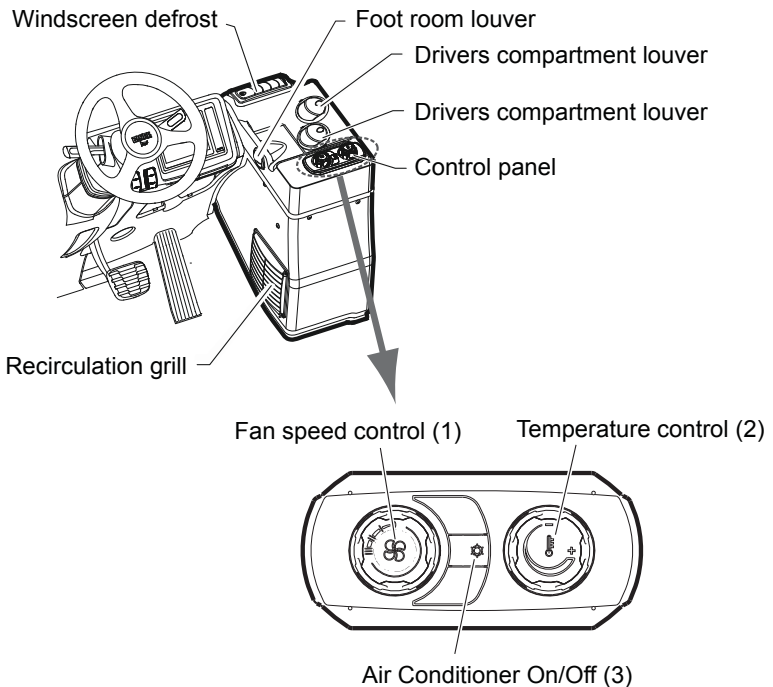

### 1. Operating the Heater

- a) Turn the fan speed control knob(1) to set the fan speed to the desired setting.
  - “0” ; Fan is turned off
  - “I” ; Low fan speed
  - “II” ; Medium fan speed
  - “III” ; High fan speed
- b) Turn the temperature control (2) to the right to increase or to the left to decrease the cabin temperature

### NOTICE

**To defrost the windscreen, set the fan speed to the highest setting and point the louvers towards the windows.**

## 2. Operating the Air Conditioner

Press the ac button (3), to turn on/off the air conditioner

### NOTICE

**To defrost the windscreen set the fan speed to the highest setting and point the louvers towards the windows. Activating the AC function during the windscreen defrost will improve the defrost performance.**



### CAUTION

**Extreme temperature differences can affect your health**

- When using the air conditioner system make sure that the temperature is no more than 6°C (43 °F) different to the outside air temperature.
- Keep the doors and windows closed when the air conditioning system is switched on.
- There should be no draft effect.

Replacement of the air filters

- a) Loosen the screws on the sides of the heater cover.
- b) Pull the cover from the heater.
- c) Remove the heating unit from the bracket, so that the right hand side of the heating unit will be accessible.
- d) The filters can be accessed from the right hand side of the forklift

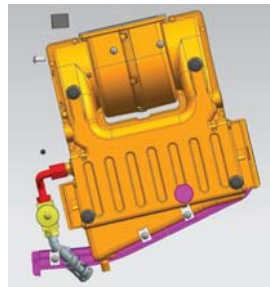

Heating Unit

## 3. Operating the Windshield Wipers

Switches for the front and rear wiper are located to the left of the drivers head while seated in the cabin. The front and rear wipers can be activated independently of each other by operating their respective switches.

## Truck Data and Capacity Plate

1. Truck model number or registered name.
2. Truck serial number - An identification number assigned to this particular truck and should be used when requesting information or ordering service parts for this truck from your authorized CLARK dealer.

CLARK		From the factory this truck meets ANSI/ITSDF B56.1		
Model	1	Type	Serial No.	2
Attachments	3			in
Rearward Tilt	deg	D	A	mm
				lb
				kg
				lb
				kg
				lb
				kg
*Capacities are with attachment or loads with upright in vertical position. *Capacities are for centered or split loads, as indicated by dimens.		D/Tire Width	in	mm
		D/Tire Type	B	
Truck Weight	5	lb or	kg	Max Battery
Electric Truck is without Battery.		kg		lb or
				kg
Max. Amp Hrs.		Volts	Battery Type	
Made in Korea		For other capacities consult Clark Material Handling Co., Lexington, KY 4052188		

3. Attachment description (if any installed) - The user must see that the truck is marked to identify the attachment(s), including the weight of the truck/attachment combination and truck capacity with the attachment.
4. Capacity rating, load center, and lifting height data - Shows the maximum load capacity of this truck with relation to load centers and fork heights (see diagram on plate). Personal injury and damage to the truck can occur if these capacities are exceeded. **Do not exceed the maximum capacity specified.**
5. Truck weight - The weight of the truck without a load on the forks. This weight plus the weight of the load must be considered when operating on elevators, elevated floors, etc. to be sure they are safe.



### CAUTION

When attachments are added or if the truck is modified, the capacity of the truck may be affected. Contact your authorized CLARK dealer for a new nameplate showing the revised capacity.

### IMPORTANT

OSHA and international standards requires prior written approval from the manufacturer before any modifications affecting capacity or safety may be made.

## Operator Safety Warning Decal

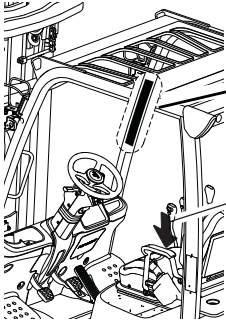

### IMPORTANT

Safety and warning decals are placed in conspicuous locations on the truck to remind you of essential procedures or to prevent you from making an error that could damage the truck or possibly cause personal injury. You should know, understand, and follow these instructions. Safety and warning decals should be replaced immediately if missing or defaced (damage or illegible). Refer to your Service Manual for location of all decals.

### Operator/Tip-Over

This decal is located on the front right hand leg of the drivers overhead guard. It is to remind the operator that staying in the seat provides the best chance of avoiding injury in the event of a tip-over or off the dock mishap.

Lift trucks can be tipped over if operated improperly. Analysis of lift truck accidents has shown that the driver can rarely react quickly enough to jump clear of the truck and overhead guard as the truck tips. To protect operators from severe injury or death in the event of a tip-over, it is best to be held securely in the seat. So, please, always buckle up when driving your lift truck.







### Upright Warning Decal

This safety decal is on the upright to warn of the danger of injury from movement between rails, chains, sheaves, fork carriage, and other parts of the upright assembly. Do not climb on or reach into the upright. Personal injury will result if any part of your body is put between moving parts of the upright.

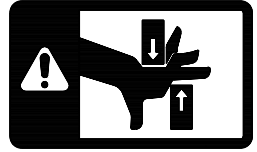

### Keep Away From Forks Decal

This safety decal is placed on the upright to warn of the danger of injury from forks when they are in the raised position. Do not ride on or stand under forks or attachments. The forks can fall and cause injury or death. Always make sure that the forks are in the fully lowered position when they are not being used to handle a load.



## Attached Position of Safety Decals



**CAUTION**

Do not operate a lift truck with damaged or missing decals or data plates. Replace them immediately. They contain important information. Contact your local CLARK dealer to acquire new decals or data plates.

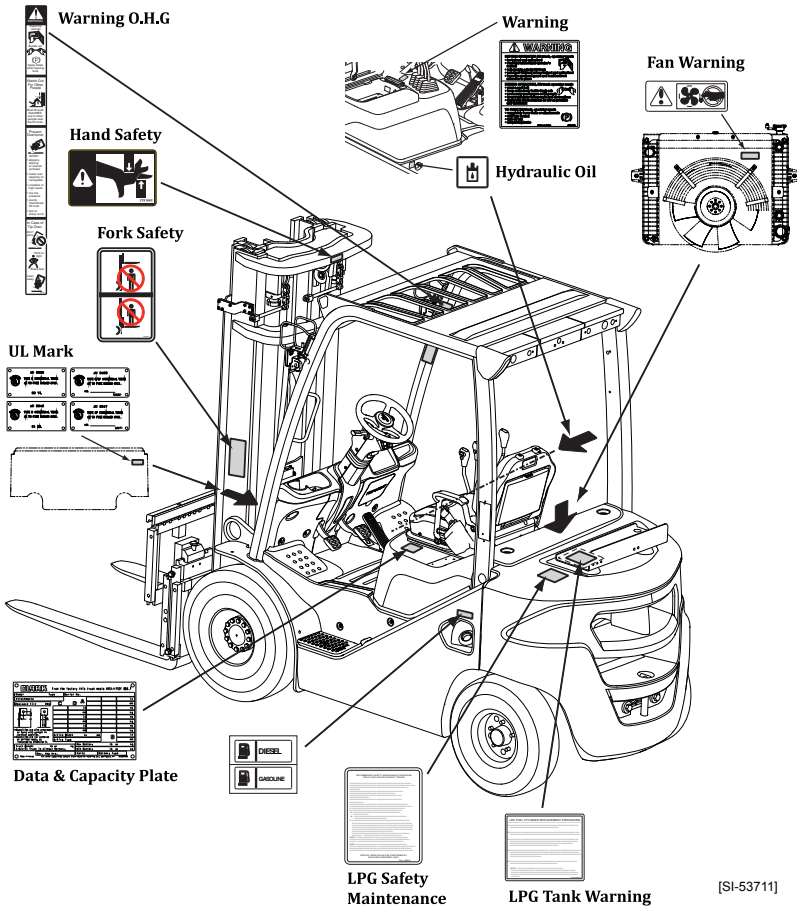

**NOTE :** Not all and these decals may be applicable to your lift truck.



# Operating Procedures

## Contents

Before Operating the Truck .....	4-2
Starting From a Safe Condition .....	4-3



## Before Operating the Truck

Be sure that you have read and understood the information in this Operator's Manual before operating the lift truck.

The Operator's Manual Holder is located on the back of the seat.

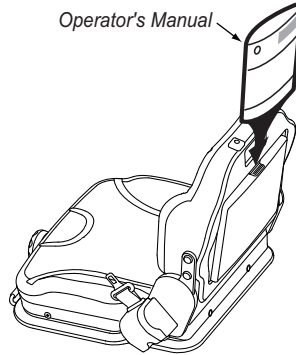

### WARNING

- This equipment can be dangerous if not used properly. Safe operation is the responsibility of the operator.
- Do not start or operate the truck, or any of its functions or attachments, from any place other than the designated operator's position.



### CAUTION

- Inspect your lift truck before operating at the start of the day or shift. Before putting your truck to use, check the operation of the controls and all systems.
- Protect yourself. Do not operate truck without a driver's overhead guard. Do not remove overhead guard unless specifically authorized. If operation without this safety device is required, a risk management system must be implemented and used with great care.

## Starting From a Safe Condition

Always start from a safe condition. Before operating a lift truck, make sure that:

1. Parking brake is applied.
2. Forks are fully lowered to the floor or ground.
3. You are familiar with how all the controls function and have read the Operator Manual.
4. All controls are in neutral or other correct position.
5. Truck has received its daily inspection and is ready and safe to operate.

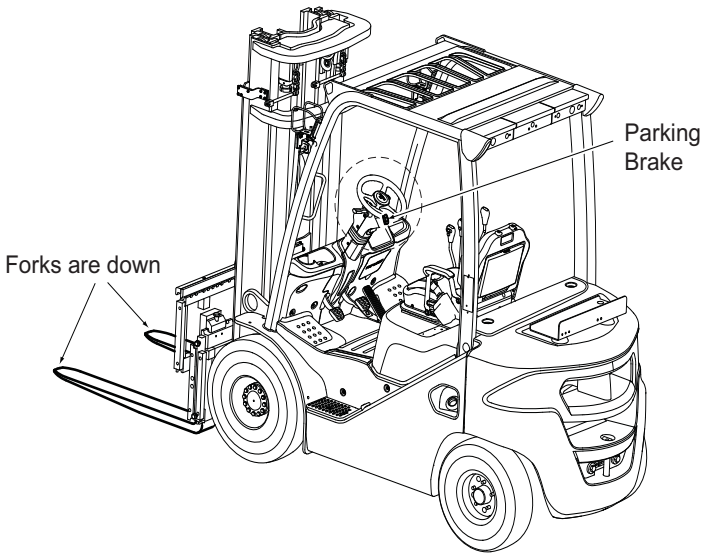

**Put the direction control lever in the NEUTRAL position, before turning the key switch to ON.**

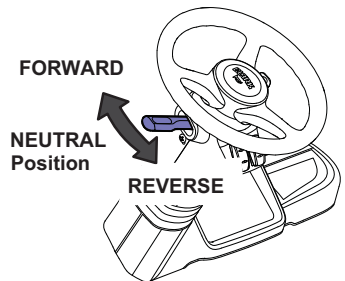

## Adjusting the Seat

Adjust the seat to a comfortable position for you. Adjust the seat by moving and holding the release lever at the front bottom of the seat. Put the seat in a position that will provide easy reach to all controls. Release the seat lever. Make sure that the seat locking mechanism is engaged.

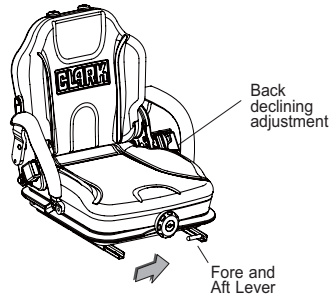

### CAUTION

**Never adjust the driver's seat while the truck is moving, to avoid the possibility of loss of control and of personal injury.**

## Buckling Up

Buckle up. Be sure that you put on the seat belt. Connect and adjust the seat belt strap to a snug, comfortable position.

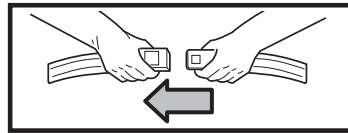

### WARNING

**Always wear your seat belt when operating a lift truck.**

## Starting the Truck

Before you start the truck, make sure that you have taken all the above mentioned precautions and that the directional control is in NEUTRAL. To start the truck, turn the key switch clockwise to the ON position.

## Positioning Forks and Upright

When driving, with or without a load, it is good practice to have the forks slightly raised and tilt the upright (forks) backward. Having the forks raised and tilting back prevents the fork tips from catching on possible obstructions and reduces the wear on the fork blades from striking or dragging on the floor or ground. See the NOTICE and CAUTION below.

Pull back on the lift control lever and raise the forks 150 to 200 mm (6 to 8 inches) above the floor. Then, using the tilt control, tilt the upright back slightly to raise the fork tips.

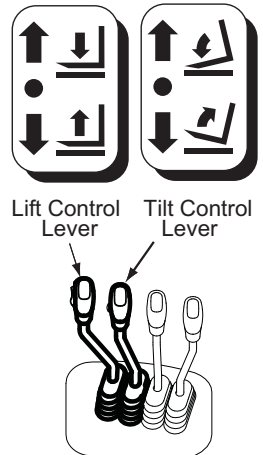

### NOTICE

When the upright (carriage and/or load) is raised, the stability of the truck is reduced. Some of the other conditions that may affect stability are: ground and floor conditions, grade, speed, loading, dynamic and static forces and the judgement exercised by the operator. Trucks equipped with attachments behave as partially loaded trucks even when operated without a load on the attachment. Also, improper operation, faulty maintenance or poor house-keeping may contribute to a condition of instability.



### CAUTION

For stability reasons, do not travel with the load or carriage raised into a high (elevated) position. Travel with the lift mechanism raised only enough to clear the ground or obstacles.



### WARNING

If your truck starts to tip over, **DO NOT JUMP!** Your chances for survival in a tip-over are better if you stay with the truck, in your seat. **BRACE YOURSELF!** Make sure your seat belt is fastened securely. Stay in your seat. Grip the wheel. Brace your feet. See page 1.14

## Controlling Speed

With the direction control in FORWARD or REVERSE, the parking brake released, put your foot on the accelerator pedal and push down smoothly until the truck is moving at the desired speed.

## Braking

To stop the truck, lift your foot from the accelerator pedal and put it on the brake pedal. Push down on the brake pedal in a smooth, firm motion until the truck is stopped.

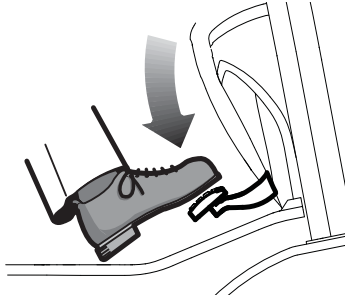

### IMPORTANT

**Stop a lift truck as gradually as practical. Hard braking and wheel sliding are dangerous and can cause tip-over or the truck could lose its load. Also, hard braking can increase wear and can be harmful to the lift truck.**



## Operating Safely

### IMPORTANT

**Safe operation is the responsibility of the operator. Watch where you are going. Don't go if you can't see.**

Before driving, check all around to be sure that your intended path of travel is clear of obstructions and pedestrians.

While driving, be alert for pedestrians, other vehicles or obstructions in your path of travel.

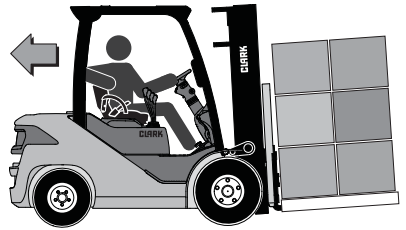

Watch people. Do not allow anyone to stand or pass under the load or raised forks. Watch for people in your work area even if your truck has warning lights or alarms. They may not watch for you.

Sound horn at intersections and wherever vision is obstructed. Do not drive a truck up to anyone standing in front of an object.

### Protect yourself and those around you...

Operate the truck only from the designated operator's position. Stay within the confines of the lift truck profile dimensions. Keep arms, legs and hands inside the operator's compartment and away from the danger of passing obstructions. Keep under the overhead guard.

### NOTICE

**An overhead guard is intended to offer protection to the operator from falling objects, but cannot protect against every possible impact. Therefore, it should not be considered a substitute for good judgement and care in loading, handling, storage, etc..**

Keep clear of the upright and lift mechanism. NEVER reach into or put hands, arms, legs or head into or through the upright structure or near the carriage or lift chains. Never put any part of your body between the upright and the truck. Don't use the upright as a ladder.

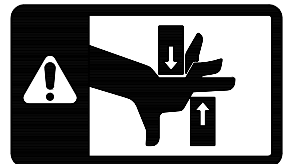

Keep all other persons clear of the load and upright mechanism while attempting to handle a load.

### **No riders...**

Do not carry passengers. The operator is the only one who should be on the truck.

### **Always be in full control of your lift truck...**

Never operate a lift truck or its attachments if you are not in the designated operator's position.

Never operate a lift truck when your hands are wet or greasy.

Always pick the smoothest travel route for your lift truck. Avoid bumps, holes, slick spots, and loose objects or debris in your path that may cause the truck to swerve or tip. If these conditions are unavoidable, slow down and carefully drive past them. Slow down for wet or slippery surfaces.

Avoid any sudden movement. Start, stop, travel, steer, and brake smoothly.

Operate your lift truck under all conditions at a speed that will permit it to be brought safely to a stop.

Some trucks will be equipped with devices to assist with slow-speed maneuvering, such as mirrors or cameras. These devices are to be used only during slow-speed maneuvering operations. The driver must face the direction of travel during normal operation of the truck.



### **WARNING**

**Travel slowly when turning. Use special care when traveling without a load because the risk of tipping over is greater with an empty truck, especially at high speed and when cornering.**

Travel with the fork carriage tilted back and raised only enough to fully clear the ground or obstacles. When the carriage (load) is elevated, the stability of the truck is reduced.

Do not elevate the load except during stacking.

### Grades, ramps, and inclines...

Use special care when operating on ramps, inclines, and uneven areas. Travel slowly. Travel straight up and down. Do not turn or drive at an angle across an incline or ramp.

When the truck is loaded, travel with the load upgrade. When the truck is empty, travel with lifting mechanism (upright) downgrade.

### Practice safe operation every time you use your truck...

Careful driving and operation is your responsibility. Be completely familiar with all the safe driving and load handling techniques in this operator's manual. Use common sense. Drive carefully; do not indulge in stunt driving or horseplay. Observe traffic rules. Watch for people and hazards. Slow down. Be in full control of your lift truck at all times.

Follow the instructions in this manual to avoid damage to your truck or the possibility of injury to yourself or others.

During your work, observe all functions of your lift truck. This allows you to immediately recognize a problem or irregularity that could affect the safe operation of your truck.

Periodically check the gauges and warning indicator lights in the instrument panel to be sure they indicate a normal condition. If an abnormal condition appears, shut off the key switch immediately and report the problem.

### IMPORTANT

**Do not continue to operate a truck that has a malfunction. Stop and have it fixed.**

### IMPORTANT

**Always wear your seat belt when operating your lift truck.**

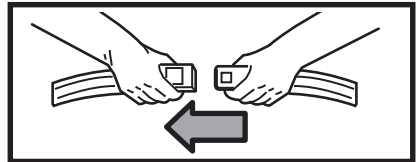

## CAUTION

Operate your lift truck only in areas that have been approved for your lift truck type designation. Certain areas contain flammable gases, liquids, dust, fibers, or other hazardous materials. Lift truck operations in these areas must have special approval. These areas must be designated to show the type of lift truck approval required for operation in the area. Be aware that changes to special equipment or poor maintenance can cause the lift truck to lose its special approval. Be sure that your truck is the correct fire safety type for the area in which you are working. The proper type designation for this truck is listed on the nameplate. In areas classified as hazardous, use only trucks approved for use in those areas. If you are unsure of the classification of the area you wish to enter, check before entering.

## Adjusting the Load Forks

The load forks are adjustable on the hanger shaft. Forks should be spaced as far apart as the load being carried will allow. Both forks should always be the same distance from the center of the fork carriage. To adjust the forks, raise the carriage slightly. Tilt the upright fully forward to reduce friction and make the forks slide easier. Unlock the fork locking pins. Position the forks. Secure the fork locking pins.

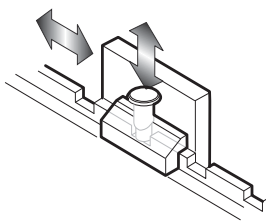

Forks are heavy, keep fingers clear. Move forks by pushing with one foot while holding on to the load back rest with hands. Be sure to have firm footing before attempting to move forks. Do not attempt this where the floor is slippery or wet.

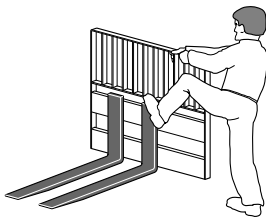

## Load Handling

Handle only loads that are within the truck rated capacity as shown on the nameplate. This rating specifies the maximum load that should be lifted. However, other factors such as special load handling attachments, loads having a high center of gravity, or uneven terrain may dictate that the safe working load be less than the rated capacity. Under these conditions, the operator must reduce the load carried so that the lift truck remains stable.

Handle only stable or safely arranged loads. Do not handle loads made up of loose, unevenly stacked or unstable items that can easily shift and fall. Take the time to correctly stack and band loose items. Center the load on the forks.

Do not lift anything that might fall on the operator or a bystander.

Do not handle loads that are higher than the fork carriage unless the load is secured so that no part of it can fall backwards.

Keep the load back against the carriage. Loads placed out on the ends of the forks can make the lift truck less stable and more likely to tip up.

Lift and lower with the upright must vertical or tilted slightly back — **never tilted forward.**

Operate lift and tilt controls slowly and smoothly. Never tilt forward when carriage (load) is raised, except to pick up or deposit a load over a rack or stack.



### WARNING

**Slack chains mean rail or carriage hang-up. Raise the upright before you move. If the upright malfunctions in any way or becomes stuck in a raised position, operate the lift control to eliminate any slack chains. DO NOT go under a raised upright or forks to attempt repairs. DO NOT reach into or climb on upright to free hang-up.**

Remember, your lift truck is designed to carry loads forward of the front wheels so that the weight of the load is counter-balanced by the weight of the truck.

The farther the load is carried from the pivot point (center of front wheels), the greater will be the uplift at the rear of the truck. Therefore, always carry the load as close to the front wheels as possible (back and flush against the face of the forks).

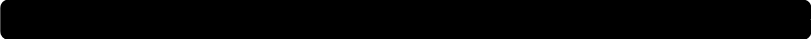

The capacity load shown on the nameplate is represented by a cube in which the weight is evenly distributed, with the center of gravity located a standard distance from the face of the forks. If the weight of the actual load to be handled is not evenly distributed, put the heaviest part closest to the carriage.

## **Travelling with a Load**

Travel with load or carriage as low as possible and tilted back. Never travel with the load or carriage raised (elevated) in a high position. Do not elevate the load except during stacking.

Observe all traffic regulations and watch for other traffic, pedestrians, and safe clearances. Always look in the direction of travel. Keep a clear view of the path of travel, and when the load blocks your visibility, travel in reverse with load trailing (except when climbing an incline).

Avoid sudden movements when carrying a load—start, stop, travel, steer, and brake smoothly. Steer clear of bumps, holes, and loose materials or debris on the ground. Lift and tilt slowly and smoothly. Go slowly when turning. Cross railroad tracks slowly at an angle wherever possible.

Use special care when handling and traveling with long, high, or wide loads—to avoid losing the load, striking bystanders or obstructions, or tipping the truck.

Watch clearances around the truck and load as you travel. Raise the forks or attachment only to pick up or stack a load. Look out for obstructions, especially overhead.

Be aware that exaggerated tail swing, when turning while traveling forward, is a characteristic of lift trucks that are steered by the rear wheels. Accordingly, you need to become accustomed to tail swing and always check the tail swing area of the counterweight to be sure it is clear before you turn.

Always be concerned about the stability of your lift truck. When attachments are used, extra care should be taken in securing, manipulating, positioning, and transporting the load. Because attachments generally add extra weight and complexity to the truck, operate trucks equipped with attachments as partially-loaded trucks when not handling a load.

## Picking Up and Moving Loads

When picking up a load from the ground, approach the load slowly and carefully align the truck square with the load. The forks should be adjusted to fit the load or pallet being handled and spread as wide as possible to provide good stability and balance. Before lifting, be sure the load is centered and the forks are fully under and supporting the load. Fork length should be at least  $\frac{2}{3}$  of load length. With the lift and tilt controls, adjust the forks to the correct height and angle for freely engaging the load pallet. Move forward until the forks are squarely and completely under the load.

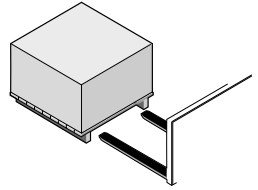

### NOTICE

**Be sure that the forks do not extend beyond the load, causing damage or tipping of other adjacent loads or materials behind the load being moved.**

If the forks are longer than the load, move the tips partially under the load without extending beyond the load. Raise the load to clear the floor. Back out several inches, or whatever distance is necessary, then set the load down and move forward until the load is positioned against the carriage.

Raise the load from the floor or stack by tilting the upright back just enough to lift the load from the surface. When stacking or tiering, use only enough backward tilt to stabilize the load.

Then raise the load to traveling height and tilt fully back to travel (except for loads that must be transported as level as possible).

## Unloading

To deposit a load on the floor after being moved into the correct position, tilt the upright forward to a vertical position and lower the load.

Adjust the fork height and tilt the upright forward slightly, as necessary, for smooth removal of the forks from the load (pallet).

Carefully back away to clear the forks from the load.

Raise the forks to traveling height and tilt fully back.

## Stacking

To put a load on a stack:

1. Approach slowly and align the lift truck and load squarely with the stack.

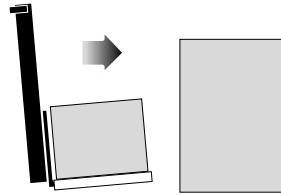

2. Raise (elevate) the load as the lift truck is nearing the stack.

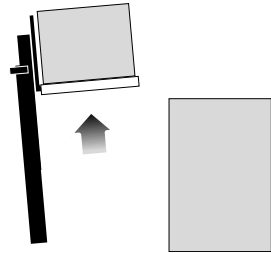

3. Move forward, slowly, until the load is almost touching the stack. The leading edge and sides of the load pallet should be lined up exactly with the near edge and side of the load or rack on which you are stacking.

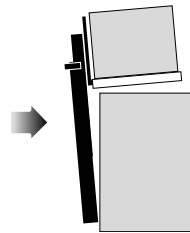

4. Stop close to the stack and further lift (raise) the load high enough to clear the top surface of the stack. Slowly move the load into position. Be careful not to damage or move adjacent loads.

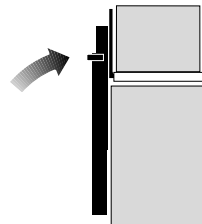

5. When the load is aligned with the stack beneath it, tilt the upright to the vertical position and carefully lower the load onto the top surface of the stack.



- Lower (drop) the forks slightly to clear (disengage) the load pallet. Tilt the forks forward slightly, if necessary.

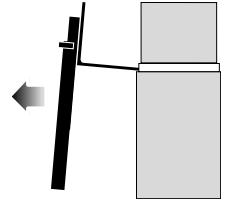

- Check your travel path, then carefully back away until the forks are clear of the stack. Stop and lower the forks to the travel position (6 to 8 inches above the ground), then tilt back to travel.

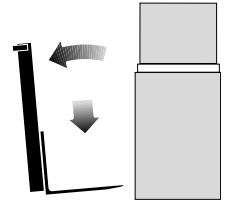

### To move a load from a stack:

Approach the stack carefully, truck lined up squarely with the load. With the truck just in front of the stack and the upright must vertical, raise the forks to the correct height for freely engaging the load pallet. Adjust fork angle as necessary to fit squarely under the load. Move forward until the forks are under the load.

**Be sure that the forks do not extend beyond the load**, causing damage or tipping of other adjacent loads or materials behind the load being moved. If the forks are longer than the load, move the tips partially under the load without extending beyond the load. Raise the load to clear the undersurface. Back out several inches, then set the load down and move forward until the front face of the forks contacts the load.

Raise the load from the stack by tilting the upright back just enough to lift the load from the surface. Or, with the mast still vertical, raise the forks until they begin to lift the load. At this point, apply the minimum back tilt that will stabilize the load.

Check your travel path, slowly back off until clear of the stack, stop, and then lower the load to the travel position (6 to 8 inches off the ground). Tilt full back to travel (except for certain loads that may have to be transported as level as possible). Be sure the load is back flush against the carriage or front face of the forks.

### NOTICE

**Certain loads may have to be transported as level as possible.**

## After Operating the Truck

**Always leave your lift truck in a safe condition.** When you leave your truck, or park it, follow these safety rules:

- Park in a safe area away from normal traffic.
- Never park on a grade.
- Never park in areas that block emergency routes or equipment, access to fire aisles, or stairways and fire equipment.

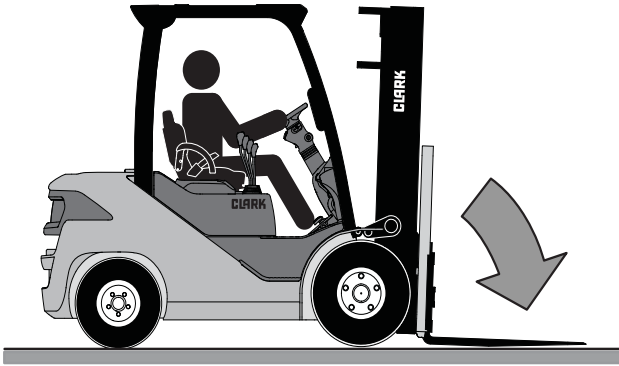

Before leaving the operator's position:

1. Bring truck to complete stop.
2. Put the directional control lever in the NEUTRAL position.
3. Lower the lift mechanism fully.
4. Set the parking brake (applies automatically).
5. Turn the key switch to the OFF position.

If you are going to leave the truck unattended:

6. Remove the key.
7. Block the wheels if the truck has any possibility of moving.

# Operator Maintenance and Care

## Contents

Daily Safety Inspection .....	5-2
Fuel Safety Practices .....	5-5
Refueling LPG Tanks .....	5-6

## NOTICE

The Occupational Safety and Health Act (OSHA) requires that truck users examine their trucks before each shift to be sure they are in safe working order. Defects when found shall be immediately reported and corrected. The truck shall be taken out of service until it has been restored to safe operating condition.



## Daily Safety Inspection

Before using a lift truck, **it is the operator's responsibility** to check its condition and be sure it is safe to operate.

Check for damage and maintenance problems; have repairs made before you operate the truck. Unusual noises or problems must be reported immediately to your supervisor or other designated authority.

Do not make repairs yourself unless you are trained in lift truck repair procedures and authorized by your employer. Have a qualified mechanic make repairs using genuine CLARK or CLARK-approved parts.



### CAUTION

**Do not operate a truck if it is in need of repair. If it is in an unsafe condition, remove the key and report the condition to the proper authority. If the truck becomes unsafe in any way while you are operating it, stop operating the truck, report the problem immediately, and have it corrected.**

Lift trucks should be inspected every eight hours, or at the start of each shift. In general, the daily inspection should include the **visual** and **functional checks** described on the following pages.

As an aid in carrying out this inspection, CLARK has prepared a form called the **"Driver's Daily Checklist."** We recommend that you use this form to make a daily record of your inspections and truck condition. You may obtain copies of this form from your CLARK dealer.



### WARNING

**Leaking hydraulic oil may be hot or under pressure. When inspecting a lift truck, wear safety glasses and do not check for leaks with bare hands.**

## Visual Checks

First, perform a visual inspection of the truck and its major components:

1. Walk around your lift truck and take note of obvious damage that may have been caused by operation during the last shift.
2. Check that all capacity, safety, and warning plates or decals are attached and legible.
3. Check before and after starting engine for leaking fuel, engine coolant, transmission fluid, etc.
4. Check for hydraulic oil leaks and loose fittings.



### CAUTION

**Do not use bare hands to check. Oil may be hot or under pressure.**

5. Be sure that the driver's overhead guard, load back rest and all other safety devices are in place, securely fastened and undamaged. Inspect for damaged or missing parts, corrosion, cracks, breaks etc.
6. Check all of the critical components that handle or carry the load.
7. Look the upright and lift chains over. Check for obvious wear and maintenance problems such as damaged or missing parts, leaks, slack or broken chains, rust, corrosion, bent parts, cracks, etc.
8. Carefully inspect the load forks for cracks, breaks, bending, twists, and wear. Be sure that the forks are correctly installed and locked in their proper position.
9. Inspect the wheels and tires for safe mounting, wear condition, and air pressure.
10. Check the hydraulic sump oil level, engine oil level, and fuel level.



## Functional Checks

Check the operation of the truck as follows.

### NOTICE

**Before performing these checks, familiarize yourself with the starting, operating, and shutdown procedures in Section 4 of this manual. Also, know the safety rules given in Section 1 of this manual.**

1. Test warning devices, horn, lights, seat belt and other safety equipment and accessories.
2. Start the engine and be sure all controls and systems operate freely and return to neutral properly. Check the:
  - Gauges, meters, and indicator lights
  - Service brakes, inching pedal, and parking brake
  - Hydraulic controls: lift, tilt, and auxiliary (if installed)
  - Accelerator
  - Directional control
  - Steering system
  - Lift mechanism and any attachments.

When the functional checks are completed, follow the **standard shut-down procedures** given in Section 4, "Operating Procedures."

## Concluding the Inspection

Make a record on the "Driver's Daily Checklist" of any problems that you find. Review the checklist to be sure it has been completed and turn it in to the person responsible for lift truck maintenance. Be sure any unusual noises or problems are investigated immediately.

**Do not operate a lift truck that has a maintenance problem or is not safe to operate.**

Instead, remove the key from the ignition switch and put an "Out of Service" tag on the truck.

If all of the Daily Inspection checks were normal or satisfactory, the truck can be operated.

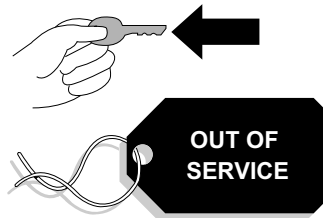

## Fuel Safety Practices

### Refueling Gasoline and Diesel Trucks

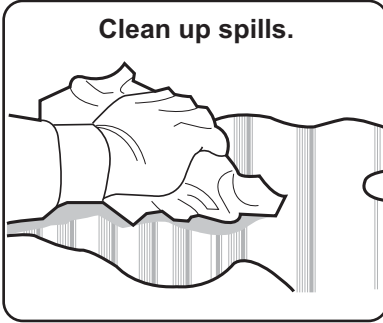

### On Isuzu Diesel Engine equipped trucks:

- Using fuel other than ultra-low-sulfur (sulfur content of 15 ppm or lower) diesel fuel may have a harmful effect on the engine, possibly resulting in a breakdown. If truck is filled with the wrong type of fuel, drain it completely. It is dangerous to start the engine with the wrong type of fuel, and doing so may result in engine damage.
- Any failures caused by the use of fuels other than ultra-low-sulfur diesel fuel are excluded from the coverage of warranty.

## Refueling LPG Tanks

When changing liquefied petroleum gas (LPG), tanks follow these basic rules:

- Change only in well ventilated areas.
- Never allow open flames.
- Turn the ignition switch to the OFF position.
- Check for leaks.
- Check condition of the O-ring.
- Make sure tank is on locating pin.
- Make sure tank latches are securely fastened.
- Store tanks according to local fire codes.

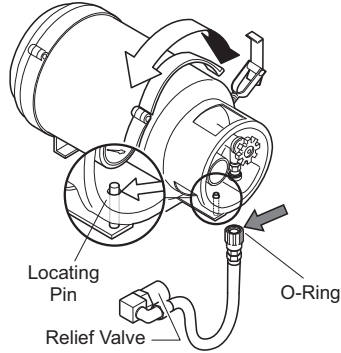

Typical Illustration

If you refill LPG tanks:

- Make sure you know and understand the proper procedure for filling an LPG tank.
- If you have any questions on refilling LPG tanks, please ask your supervisor.

### DANGER

**LPG IS HEAVIER THAN AIR.** It settles on your clothes and the ground around you, displacing oxygen vital for breathing. Open flame can cause flash fires.

### IMPORTANT

Check all connections for damage or leaks. If the truck will not start after you change tanks, get a qualified mechanic to check the truck.



## RECOMMENDED SAFETY MAINTENANCE PROCEDURES FOR LPG FUELED LIFT TRUCKS



### WARNING

**LPG is a combustible fuel that is heavier than air. Escaping gas may accumulate in low areas. The fuel cylinder should be mounted so that it does not extend outside the truck and should also be properly positioned by using the locating pin or key way.**

The fuel valve should be turned off when the machine is not in service. Cast fittings should not be used in the LPG system. Use only Underwriters Laboratories or Factory Mutual listed LPG hose assemblies where pressure fuel lines are required. All pipe threaded fittings should be installed using an approved sealing compound. Fuel lines should be supported by clamps to minimize chafing and wear. The LPG solenoid valve should be wired to an automatic shut off switch (oil pressure or vacuum) to prevent leakage of gas in the event the ignition is on without the engine running. Check the LPG solenoid or vacuum shutoff valve for leakage as follows:

1. Turn fuel tank valve off, start and run engine until it stops.
2. Install a 0 to 30 psi pressure gauge per follow instruction:
  - A. To primary test port of single units consisting of primary and secondary regulators.
  - B. Between the primary and secondary stage regulators when the LPG system consists of two regulators.
3. Turn the tank fuel valve on. The pressure gauge should maintain a zero reading. If it does not, the solenoid valve or vacuum shut-off valve must be repaired or replaced. An odor is added to LPG to help indicate leaks. If you detect gas odor, you should turn off the fuel tank supply valve and engine. Remove all sources of ignition, and ventilate the area. Make all of the necessary repairs before you turn the fuel supply on. The complete LPG system should be inspected periodically. Check all hoses for wear, connections for leaks, and all parts for damage.

**NOTE:** Fuel hoses have a limited life expectancy. They should be checked for cracking and drying due to age. Hoses with visible signs of age should be replaced. Use only Underwriters Laboratories or Factory Mutual listed LPG parts for replacements.

**NOTE:** The above information is provided as a guide. Consult the National Fire Protection Association Pamphlet 58 for the safe storage and handling of liquefied petroleum gases. Governmental safety regulations in your locality could vary. Check with the authority having jurisdiction to be sure that you meet all of their requirements. Contact the manufacturer of the LPG tank for detailed service information.



# Emergency Starting, Towing and Lowering

## Contents

How to Tow a Disabled Truck .....	6-2
How to Use Battery Jumper Cables .....	6-6
Emergency Lowering of Upright .....	6-9



## How to Tow a Disabled Truck

If the lift truck becomes disabled, and must be moved, use the following procedures to safely tow it to a repair area.

### IMPORTANT

**For your safety, and to prevent damage to the lift truck, only use approved equipment in good condition and carefully follow these rules for safe towing.**



### WARNING

**DO NOT tow a disabled lift truck if there is a problem with the brakes, tires, or steering operation. DO NOT tow on ramps or steep inclines. DO NOT tow a lift truck if the traction or weather conditions are poor.**

1. **Always block the drive wheels** of the disabled truck before beginning work around it.
2. If possible, raise the carriage (forks) of the disabled truck approximately 300 mm (12 in) from the ground. Secure the carriage with a chain.
3. Find another lift truck of equal or larger size carrying a partial load to allow for optimal traction.
4. Check that the counterweight mounting bolts are in place and properly tightened. NOTE: These bolts are made of a special high-tensile steel and are not commercially available. If replacement is needed, only use genuine CLARK replacement parts.
5. Install a solid metal tow bar with towing couplers, approved for such purpose, to the tow pin in each truck's counterweight.
6. Release the parking brake on the disabled lift truck. The parking brake automatically applies.

Refer to the following parking brake release procedures, which depend on the lift truck's specific configuration:

**(1) How to manually release the parking brake :**

(Yanmar, Isuzu, PSI, or Ford engine)

**WARNING****The drive wheels must be blocked before attempting to release the parking brake.**

- a. Remove the floor plate.
- b. Record the position of the nut (2) and the cotter pin (1) on the parking brake assemble at the rear of the transmission.
- c. Remove the cotter pin (1) using long-nose pliers.
- d. Tighten the nut (2) by hand (clockwise) until it touches the cover.
- e. Tighten the nut (2), using a 27 mm socket wrench, one (1) full turn (clockwise). The parking brake should now be released.

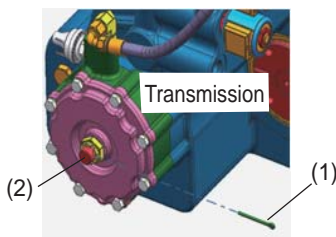
**– Returning the lift truck to service :**

- a. A certified lift truck technician must reset the parking brake before returning the lift truck to service. Refer to the Service Manual (Group 23) for this specific procedure.

**CAUTION**

**When the engine is not running, the power-assisted hydraulic steering and braking of a disabled lift truck will not function. Steering and braking effort will become difficult and affect the operation of the lift truck being towed. When towing, do not travel faster than 5 kph (3 mph), and attempt to keep the total towing distance as short as possible.**

## (2) How to manually release the parking brake : (HMC THETA engine)

If the lift truck becomes disabled and must be towed, follow the procedure described below :

No.	Part Name
1	Threaded Holes
2	Release Bolt
3	Cover
4	Plugs

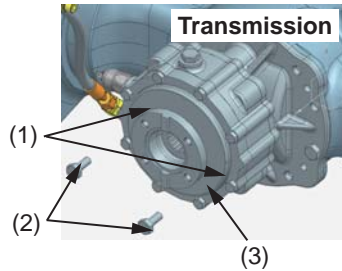

- Remove the plugs (4) from the threaded holes (1) in the parking brake assembly cover (3) located on the drive axle.
  - Install the release bolts (2) to the tapped holes. The release bolts must be the following size: **M8 x 1.25P x 30L**.
  - Alternately tighten the release bolts (2) in the clockwise direction until the bolts are fully installed. Do not overtighten the bolts. The parking brake should now be released.
- Returning the lift truck to service :

- Make sure that the engine is turned off and the drive wheels are blocked before attempting to apply the parking brake.
- Alternately loosen the release bolts (2) in the counterclockwise direction until fully removed. The parking brake should now be applied.

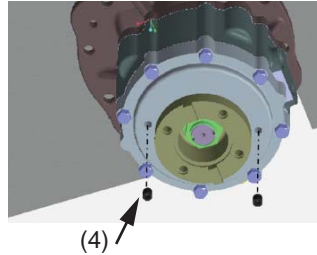

- Apply Loctite #577 to the threads of the plugs (4) and then reinstall the plugs into the threaded holes (1). Tighten the plugs to 10-14 Nm (87-130 lbf-in).
- Check that the parking brake functions correctly by parking the lift truck on a 15% grade while carrying a capacity load. The parking brake must hold the lift truck in place.

6. Make sure that the transmission control is in neutral.

### NOTICE

DOT (Department of Transportation) approved towing equipment is available from your CLARK dealer.

7. Tow the disabled lift truck backward. **An operator must be on the towed truck.** Tow the lift truck slowly. Careful towing is necessary to prevent injury to personnel or damage to the lift truck. Do not tow the lift truck at a speed greater than 5 kph (3 mph). Do not raise the lift truck or any wheels off the ground while the lift truck is being towed.

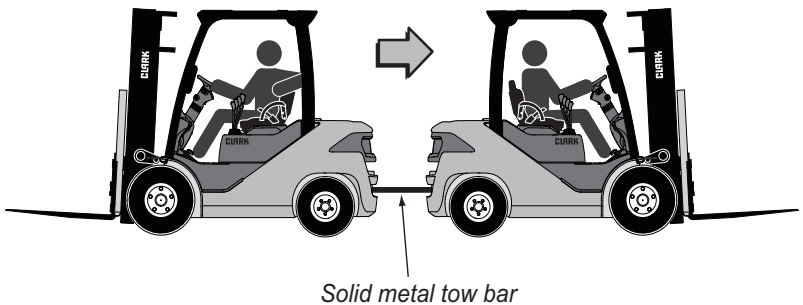

### CAUTION

The power-assisted hydraulic steering and brakes will not operate on the disabled truck when the engine is not running. Additional effort will be required to operate the steering wheel and brakes.

8. Park the disabled truck in an authorized area only, tag the lift truck OUT OF SERVICE, and remove the key.

### WARNING

Always apply the parking brake when parking a lift truck. The lift truck can move and cause injury or death to nearby personnel. In the event that the parking brake must be manually released, always block the drive tires to prevent unintended movement.

## How to Use Battery Jumper Cables



### CAUTION

If the truck is to be removed service for longer than one (1) month, then the negative (black) battery cable should be disconnected.

If the truck's battery becomes excessively discharged, then it may be required to jump start the lift truck using either another truck with a similar 12-volt, negatively grounded electrical system or an appropriate portable jump starter pack. If jump starting the truck using another lift truck, then the booster battery should be fully charged and in good condition. To avoid damaging the truck and preventing injuries to yourself or others, always read, understand, and follow the procedures and warnings described in this manual. It is recommended that this procedure be performed by a certified lift truck technician.

If the truck has a battery with side terminals, then jumper cables with connector clamps or cable adapters for side-mounted battery terminals should be used.



### CAUTION

**ONLY USE A 12-VOLT, NEGATIVELY GROUNDED SYSTEM TO JUMP START THE TRUCK.** Connecting a non-12V power supply (such as two 12-volt batteries connected in series) to the battery or electrical system, will cause damage to the truck. It can also cause injury to yourself or others.



### WARNING

**BATTERIES CONTAIN SULFURIC ACID.** When working near the battery, always use appropriate protective equipment, such as safety glasses, gloves, and apron, to prevent unintended contact with acid. If any battery acid contacts your eyes or skin, immediately flush with water and get medical attention.

1. If the excessively discharged battery has filler caps, check the fluid level. Do not use an open flame when checking the fluid level. Do not smoke when checking the fluid level. If the fluid level is low, add distilled water until the correct level is reached. Make sure to install the caps before attempting to jump start the engine. Do not jump start, charge, or test a sealed-type battery if the test indicator is illuminated or is a bright color. Use a new battery.





**WARNING**

**BATTERIES PRODUCE EXPLOSIVE HYDROGEN GAS.** Do not smoke or allow open flames or sparks near any battery charging or service area. Hydrogen gas is produced during normal battery operation and can explode when exposed to any open flames or sparks. This can cause serious injury or death. When using, charging, or servicing the battery in an enclosed space, always ensure there is adequate ventilation and shield your eyes. Always use appropriate eye protection when working near batteries.

2. Position the booster truck with its battery as near to the stalled truck as necessary for the jumper cables to reach both batteries. Make sure that the trucks do not touch each other. **Use care when connecting the booster battery to prevent arcing (sparks).**
3. For each truck:
  - a. Apply the parking brake.
  - b. Put the directional control lever in the NEUTRAL position.
  - c. Turn the keyswitch to the OFF position.
  - d. If necessary, turn all accessories to the OFF position. Leave them off until after the engine has been started and the jumper cables have been removed.



**WARNING**

**AVOID SHORT CIRCUITING.** Always remove any jewelry before attempting to install the jumper cables. Do not allow any metal tools to contact the battery terminals. When installing the jumper cable to the positive terminals of the two batteries, make sure that both clamps do not contact any other metal surface. Failure to follow this warning can result in injury, or death, from electrical shock or explosion.



4. Install the jumper cables:

a. Connect one end of a jumper cable (A) to the positive (red) terminal on the discharged battery. Connect the opposite end of the jumper cable (B) to the positive (red) terminal on the booster battery. **Do not connect positive to negative, or negative to positive.**

b. Connect one end of another jumper cable (C) to the negative (black) terminal of the booster battery. Connect the opposite end of this cable (D) to a solid, unpainted metal surface (such as the engine) of the stalled truck. **Do not connect it to the negative terminal of the discharged battery.** If connecting to the engine, or one of its components, make sure that it is at least 450 mm (18 in) away from the battery, not connected to any pulley, fan, or other component that moves, and not connected to any hot component such as the manifold(s).

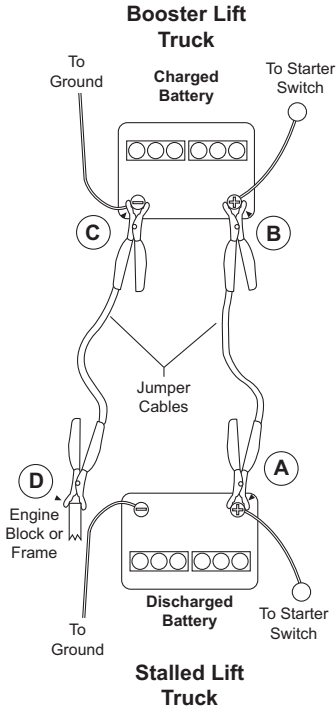

5. Turn the booster truck ON, and operate the engine at a moderate speed for at least five (5) minutes.

6. Attempt to start the stalled truck. Refer to the starting instructions shown in Section 4, "Operating Procedures" of this manual.

7. Remove the jumper cables in the reverse order of installation.

**Do not disconnect the jumper cables until the engine of the stalled truck is operating at idle speed.** Remove the jumper cable end (D) from the unpainted surface of the stalled truck, then remove the opposite end (C) from the negative terminal of the booster battery. Remove the other jumper cable end (B) from the positive terminal of the discharged battery, then remove the opposite end of the cable (A) from the positive terminal of the booster battery.

## Emergency Lowering of Upright

### CAUTION

If the lift truck loses power with the upright raised, it may be necessary to use the following procedure to bypass the lifting mechanism and lower the load to the ground. The following procedure must be performed safely and with extreme care. Make sure that you, and any nearby personnel, are safely out of the way to prevent injury.

#### Emergency lowering of upright : *with standard Manual Valve*

1. Raise the hood and locate the emergency lowering valve on the lift section of the hydraulic valve.
2. Using a 4 mm hex wrench, loosen the valve 1/4 turn.
3. Operate the lift lever to slowly lower the upright.
4. Tighten the emergency lowering valve and close the hood.

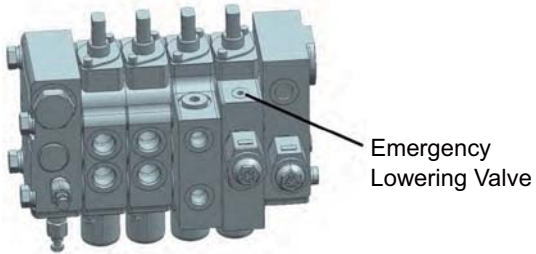

#### Emergency lowering of upright : *with optional EHL Valve*

1. Raise the hood and locate the emergency lowering valve on the EHL valve as indicated.
2. Using a 5 mm hex wrench, carefully loosen the lowering valve until the upright begins to lower. Allow the upright to slowly lower to the desired height.
3. Tighten the emergency lowering valve and close the hood.

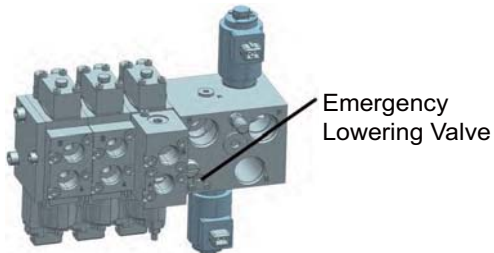



# Planned Maintenance and Lubrication

## Contents

Introduction .....	7-2
Safe Maintenance Practices .....	7-3
Major Component Locations .....	7-8
Planned Maintenance Intervals .....	7-9
PM Report Form .....	7-12
How to Perform Planned Maintenance .....	7-14

### NOTICE

**THIS SECTION IS FOR TRAINED SERVICE PERSONNEL to use as a reference for Planned Maintenance procedures. Complete maintenance information is in the Service Manuals.**



## Introduction

### NOTICE

**ONLY TRAINED AND AUTHORIZED PERSONNEL** should perform **Planned Maintenance**. Local **CLARK** dealers are prepared to help customers put in place a **Planned Maintenance program** for checking and maintaining their lift trucks according to applicable safety regulations.



### CAUTION

**Powered industrial trucks may become hazardous if maintenance is neglected.**

The operator should make a safety inspection of the lift truck before operating it. The purpose of this daily examination is to check for any obvious damage and maintenance problems, and to have minor adjustments and repairs made to correct any unsafe condition.

**In addition to the operator's daily inspection**, CLARK recommends that the owner set up and follow a periodic planned maintenance (PM) and inspection program. Performed on a regular basis **by trained** personnel, the program provides thorough inspections and checks of the safe operating condition of the lift truck. The "PM" identifies needed adjustments, repairs, or replacements so they can be made before failure occurs. The specific schedule (frequency) for the PM inspections depends on the particular application and lift truck usage.

This Section recommends typical Planned Maintenance and Lubrication Schedules for items essential to the safety, life, and performance of the truck. It also outlines safe maintenance practices and gives brief procedures for inspections, operational checks, cleaning, lubrication, and minor adjustments.

Specifications for selected components, fuel, lubricants, critical bolt torques, refill capacities, and settings for the truck are found in Section 8.

If you have need for more information on the care and repair of your truck, see your CLARK dealer.

## Safe Maintenance Practices

The following instructions have been prepared from current industry and government safety standards applicable to industrial truck operation and maintenance. These recommended procedures specify conditions, methods, and accepted practices that aid in the safe maintenance of industrial trucks. They are listed here for the reference and safety of all workers during maintenance operations. Carefully read and understand these instructions and the specific maintenance procedures before attempting to do any repair work. When in doubt of any maintenance procedure, please contact your local CLARK dealer.

1. Powered industrial trucks can become hazardous if maintenance is neglected. Therefore, suitable maintenance facilities and trained personnel and procedures shall be provided.
2. Maintenance and inspection of all powered industrial trucks shall be performed in conformance with the manufacturer's recommendations.
3. Follow a scheduled planned maintenance, lubrication, and inspection system.
4. Only trained and authorized personnel are permitted to maintain, repair, adjust, and inspect industrial trucks and must do so in accordance with the manufacturer's specifications.
5. Always wear safety glasses. Wear a safety (hard) hat in industrial plants and in special work areas where protection is necessary and required.
6. Properly ventilate work area, vent exhaust fumes, and keep shop clean and floors dry.
7. Avoid fire hazards and have fire protection equipment present in the work area. Do not use an open flame to check for leakage. Do not use open pans of fuel or flammable cleaning fluids for cleaning parts.
8. Before starting work on truck:
  - a. Raise drive wheels free of floor and use oak blocks or other positive truck positioning devices.
  - b. Remove all jewelry (watches, rings, bracelets, etc.).
  - c. Put oak blocks under the load-engaging means, innermasts, or chassis before working on them.
  - d. Disconnect the battery ground cable (-) before working on the electrical system.





## CAUTION

Refer to the “Jacking and Blocking” section in the Service Manual for proper procedures.

**Never lift the truck by the counterweight.**

9. Operation of the truck to check performance must be conducted in an authorized, safe, clear area.
10. Before starting to operate the truck:
  - a. Be seated in a safe operating position and fasten your seat belt.
  - b. Make sure parking brake is applied.
  - c. Put the direction control in NEUTRAL.
  - d. Start the engine.
  - e. Check functioning of lift and tilt systems, direction and speed controls, steering, brakes, warning devices, and load handling attachments.
11. Before leaving the truck:
  - a. Stop the truck.
  - b. Fully lower the load-engaging means: upright, carriage, forks or attachments.
  - c. Put the directional control in NEUTRAL.
  - d. Apply the parking brake (automatically occurs).
  - e. Stop the engine.
  - f. Turn the key switch to the OFF position.
  - g. Put blocks at the wheels if the truck must be left on an incline.
12. Brakes, steering mechanisms, control mechanisms, warning devices, lights, governors, lift overload devices, lift and tilt mechanisms, articulating axle stops, load back rest, overhead guard and frame members must be carefully and regularly inspected and maintained in a safe operating condition.
13. Special trucks or devices designed and approved for hazardous-area operation must receive special attention to insure that maintenance preserves the original approved safe operating features.



14. Fuel systems must be checked for leaks and condition of parts. Extra special consideration must be given in the case of a leak in the fuel system. Action must be taken to prevent the use of the truck until the leak has been corrected.
15. All hydraulic systems must be regularly inspected and maintained in conformance with good practice. Tilt and lift cylinders, valves, and other parts must be checked to assure that "drift" or leakage has not developed to the extent that it would create a hazard.
16. When working on the hydraulic system, be sure the engine is turned off, upright is in the fully-lowered position, and hydraulic pressure is relieved in hoses and tubing.



### **WARNING**

**Always put hardwood blocks under the carriage and upright rails when it is necessary to work with the upright in an elevated position.**

17. The truck manufacturer's capacity, operation, and maintenance instruction plates, tags, or decals must be maintained in legible condition.
18. Batteries, limit switches, protective devices, electrical conductors, and connections must be maintained in conformance with good practice. Special attention must be paid to the condition of electrical insulation.
19. To avoid injury to personnel or damage to the equipment, consult the manufacturer's procedures in replacing contacts on any battery connection.
20. Industrial trucks must be kept in a clean condition to minimize fire hazards and help in detection of loose or defective parts.
21. Modifications and additions that affect capacity and safe truck operation must not be done without the manufacturer's prior written approval. Capacity, operation, and maintenance instruction plates, tags, or decals must be changed accordingly.

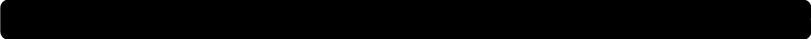
- 
22. Care must be taken to assure that all replacement parts, including tires, are interchangeable with the original parts and of a quality at least equal to that provided in the original equipment. Parts, including tires, are to be installed per the manufacturer's procedures. Always use genuine CLARK or CLARK-approved parts.



### **WARNING**

**When removing tires follow industry safety practices. Most importantly, deflate pneumatic tires completely prior to removal. Following assembly of tires on multi-piece rims, use a safety cage or restraining device while inflating.**

23. Use special care when removing heavy components, such as counterweight, upright, etc. Be sure that lifting and handling equipment is of the correct capacity and in good condition.

### **IMPORTANT**

**Your new CLARK lift truck has been built to meet all applicable mandatory requirements of ANSI / ITSDF B56.1 Safety Standard for Powered Industrial Trucks. Each truck also includes certain safety devices—such as horn, overhead guard, safety restraint system, seat belt and load back rest—as standard equipment. No additions, omissions, or modifications should be made that affect compliance to the above requirements or in any way minimize the effectiveness of the safety devices.**

**NOTICE**

**You should be familiar with additional operating and maintenance safety instructions contained in the following publications:**

*ANSI / ITSDF B56.1: Safety Standard for Low Lift and High Lift Trucks (Safety Code For Powered Industrial Trucks).*

*NFPA 505: Fire Safety Standard for Powered Industrial Trucks: Type Designations, Areas of Use, Maintenance and Operation.* Available from National Fire Protection Association, Inc., Batterymarch Park, Quincy, MA 02169.

*General Industrial Standards, OSHA 2206: OSHA Safety and Health Standards (929 CFR 1910), Subpart N-Materials Handling and Storage, Section 1910.178 Powered Industrial Trucks.* For sale by: Superintendent of Documents, US Government Printing Office, Washington, DC 20210.



## Major Component Locations

Use the illustration below to help locate components included in the PM procedures.

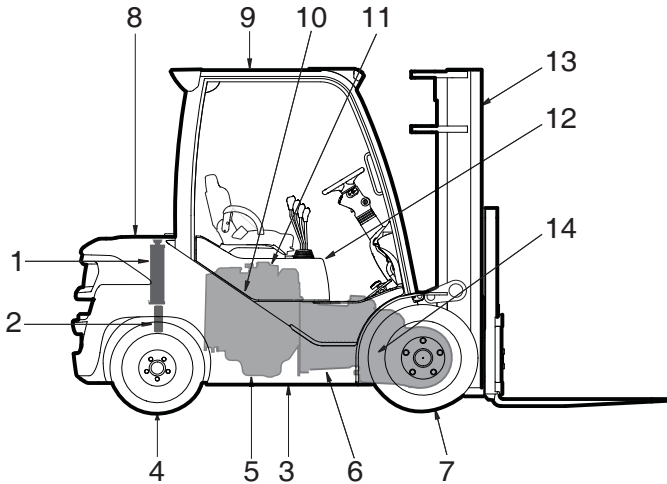

- |                         |                          |
|-------------------------|--------------------------|
| 1. Radiator             | 8. Counterweight         |
| 2. Transmission Cooler  | 9. Overhead Guard        |
| 3. Frame                | 10. Exhaust              |
| 4. Steer Axle and Wheel | 11. Carburetion          |
| 5. Engine               | 12. Sheet Metal          |
| 6. Transmission         | 13. Upright and Carriage |
| 7. Drive Axle and Wheel | 14. Drive Shaft          |

The truck shown above is a typical representation of a CLARK internal combustion lift truck. Your model may vary slightly.

## Planned Maintenance Intervals

Time intervals between maintenances are largely determined by operating conditions. For example, operation in sandy, dusty locations requires shorter maintenance intervals than operation in clean warehouses. The indicated intervals are intended for **normal** operation. The operating condition classifications are:

### Normal Operation

Eight-hour material handling, mostly in buildings or in clean, open air on clean paved surfaces.

### Severe Operation

Prolonged operating hours or constant usage or heavy loading cycles.

### Extreme Operation

- In sandy or dusty locations, such as cement plants, lumber mills, and coal dust or stone crushing sites.
- High-temperature locations, such as steel mills and foundries.
- Sudden temperature changes, such as constant trips from buildings into the open air, or in refrigeration plants.

If the lift truck is used in severe or extreme operating conditions, you must shorten the maintenance intervals accordingly.

### NOTICE

**Since the operating environment of lift trucks varies widely, the above descriptions are highly generalized and should be applied as actual conditions dictate.**



The maintenance time intervals referred to in this manual relate to truck operating hours as recorded on the hourmeter, and are based on experience CLARK has found to be convenient and suitable under typical (normal or average) operating conditions. The periods and their designations are:

PM Interval:

A=8 - 10 hours or daily

B=50 - 250 hours or every month (typical PM interval)

C=450 - 500 hours or every 6 months

D=900 - 1000 hours or every 12 months

E=2000 hours or every year

PERIODIC CHECKS and PLANNED MAINTENANCE (PM)	A	B	C	D	E
Check truck visually and inspect components.			•		
Test drive truck/check functional performance.			•		
Air clean truck and radiator.			•		
Check torque on critical fasteners.			•		
Lubricate truck. (See component)			•		
Drain and replace engine oil.			•		
Replace engine oil filter.			•		
Clean and replace LPG/Gas engine air filter. (*)					•
Clean and replace Diesel engine air filter. (*)				•	
Change Diesel fuel filter.				•	
Change LPG/Gas fuel filter.				•	
Drain heavy ends from vaporizer.			•		
Inspect / adjust fan belts.			•		
Drain / flush radiator coolant.					•
Check engine ignition and timing.			•		
Engine tune-up.					•
Check battery.			•		
Check transmission fluid level.			•		
Change transmission fluid. (drain and replace)					•
Change (replace) transmission oil filter.				•	
Change drive axle fluid. (cooling system not equipped) - Cooling system equipped : 2,000 hours				•	
Clean drive axle air vent.				•	
Check brake condition and wear.			•		
Check drive axle mounting and fasteners.				•	
Lubricate steer axle linkage.				•	
Check / lubricate steer axle wheel bearings.					•
Change / replace hydraulic sump oil filter and breather.				•	
Change / replace hydraulic sump fluid and oil filter.					•
Lubricate tilt cylinder rod ends.			•		
Check lift chain adjustment and wear.			•		
Check / lubricate lift chains.			•		
Lubricate upright rollers.			•		
Timing belt replace (MMC/PSI Only) : 5,000 hours					

**NOTES:**

- \* Air filter change interval may be determined by using an air restriction indicator.

**CAUTION**

**Breather interval for very dirty environment : every 500 operating hours, at least twice a year.**

DAILY MAINTENANCE CHECKS	A	B	C	D	E
Check truck for obvious damage and leaks.	•				
Check fuel system for leaks, etc.	•				
Check capacity, warning plates and decals.	•				
Check condition of tires and wheels. Remove embedded objects. Check air pressure.	•				
Check for missing or loose wheel lugs nuts.	•				
Check engine oil level.	•				
Check engine coolant level (radiator and recovery tank)	•				
Check transaxle fluid level	•				
Check fuel level.	•				
Check hydraulic sump oil level.	•				
Check gauges and instruments.	•				
Check warning lights and hour meter.	•				
Check overhead guard condition and bolts.	•				
Check horn operation and other warning devices.	•				
Check steering operation.	•				
Check service brake operation.	•				
Check parking brake operation.	•				
Check parking brake linkage for damage, broken parts.	•				
Check directional and speed controls operation.	•				
Check accelerator and engine speed operation.	•				
Check lift, tilt and aux. operation.	•				
Check upright, lift chains and fasteners.	•				
Check carriage or attachments and forks.	•				
Check seat deck hold-down latch for correct locking.	•				
Check optional safety equipment. (alarms, lights etc.)	•				
Check for presence and operation of seat belt.	•				

## PM Report Form

Make and keep records of your PM inspections. Use these records to help establish the correct PM intervals for the truck application and to indicate maintenance required to prevent major problems from occurring during operation.

As an aid in performing and documenting your PM inspections, CLARK has prepared a ***Gasoline, LPG, or Diesel Planned Maintenance Report Form***. Copies of this form may be obtained from your authorized CLARK dealer. We recommend that you use this form as a checklist and record of your inspection and truck condition.

The maintenance procedures outlined in this Section are intended to be used in conjunction with the PM Report Form. They are arranged in a logical and efficient sequence.

You make a check mark or entry on the PM Report Form when the PM is performed. A special coding system for indicating the importance of needed repairs and/or adjustments appears on the form.

When you have finished the PM inspections, be sure to give a copy of the report to the designated authority or person responsible for lift truck maintenance.

Do not make repairs or adjustments unless authorized to do so.



### CAUTION

For safety, it is good practice to:

- **Remove all jewelry (watch, rings, bracelets, etc.) before working on the truck.**
- **Disconnect the battery ground cable (-) from the battery before working on electrical components.**
- **Always wear safety glasses. Wear a safety (hard) hat in industrial plants and in special work areas where protection is necessary and required.**





# How to Perform Planned Maintenance

## Visual Inspection

First, perform a visual inspection of the lift truck and its components. Walk around the truck and take note of any obvious damage or maintenance problems.

Check to be sure all capacity, safety, and warning plates are attached and legible.

### NOTICE

**NAME PLATES AND DECALS:** Do not operate a lift truck with damaged or lost decals and nameplates. Replace them immediately. They contain important information.

Inspect the truck, before and after starting the engine, for any sign of external leakage of fuel, engine coolant, transmission fluid, etc.

Check for hydraulic oil leaks and loose fittings.



### CAUTION

**HYDRAULIC FLUID PRESSURE:** Do not use your hands to check for hydraulic leakage. Fluid under pressure can penetrate your skin and cause serious injury.

## Changing the Engine Oil and Oil Filter

Remove the filter cartridge.

Lightly grease the sealing ring on the new filter cartridge and screw in the cartridge until it is hand tight.

Remove the oil pan drain plug to drain old oil after the truck has been in operation and the engine (oil) is at operating temperature.

Carefully check for leaks after changing oil and installing new filter.

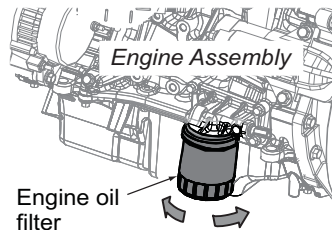

## Overhead Guard

Be sure that the driver's overhead guard and any safety devices are in place, undamaged, and attached securely.

Check the overhead guard for damage. Be sure that it is properly positioned and all mounting fasteners are in place and tight.

The overhead guard must not be modified from CLARK specification.

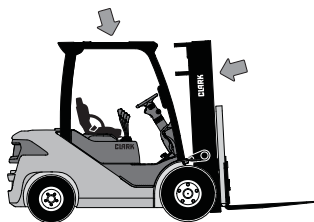

## Load Handling Components

Inspect the upright assembly, load backrest (LBR), rails, carriage, rollers, lift chains, and lift and tilt cylinders. Look for obvious wear and maintenance problems and damaged or missing parts. Check for any loose parts or fittings. Check for leaks, damaged or loose rollers, and rail wear (metal flaking). Carefully check the lift chains for wear, rust, corrosion, cracked or broken links, stretching, etc. Check that the lift and carriage chains are correctly adjusted to have equal tension. Check that the lift chain anchor fasteners and locking means are in place and tight. Inspect all lift line hydraulic connections for leaks.

### IMPORTANT

**Uprights and lift chains require special attention and maintenance to remain in safe operating condition. Refer to “Lift Chain Maintenance” in this Section for additional information.**

## Load Backrest

Check the condition of the load backrest. Inspect the welds on the load backrest and carriage for cracks. Check that the load backrest mounting fasteners are not missing and are properly tightened to specification. If the load backrest has been removed, make sure that fork stops have been installed on each side of the carriage.

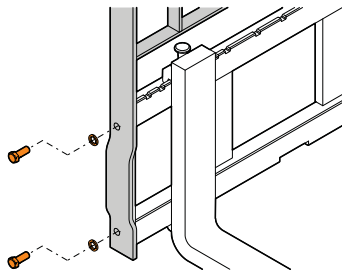

## CAUTION

If the lift truck is not equipped with a load backrest, or it has been removed, then fork stops must be installed on each side of the carriage to prevent the forks from being unintentionally forced off of the carriage during operation.

## Forks

Inspect the load forks for cracks, breaks, bending, and wear. The fork top surfaces should be level and even with each other. The height difference between both fork tips should be no more than 1.5% of the blade length.

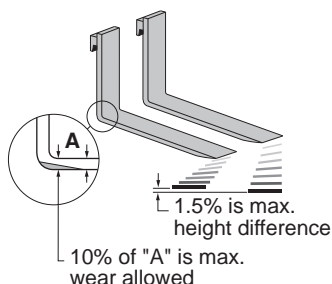

## WARNING

If the fork blade at the heel is worn down by more than 10%, the load capacity is reduced and the fork must be replaced.

Inspect the forks for twists and bends. Put a 50mm(2") - thick metal block, at least 100mm(4") wide by 600mm(24") long with parallel sides, on the blade of the fork with the 100mm(4") surface against the blade. Put a 600mm(24") carpenter's square on the top of the block and against the shank. Check the fork 500mm(20") above the blade to make sure it is not bent more than 25mm(1") maximum.

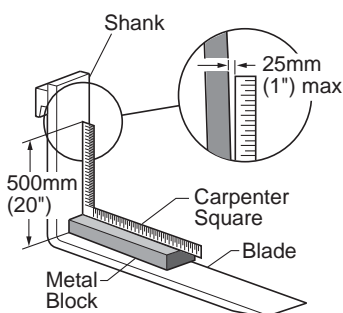

If the fork blades are obviously bent or damaged, have them inspected by a trained maintenance person before operating the truck.

Inspect the fork locking pins for cracks or damage. Reinsert them and note whether they fit properly.

## Wheels and Tires

Check the condition of the drive and steer wheels and tires. Remove objects that are embedded in the tread. Inspect the tires for excessive wear and breaks or “chunking out.”

Check all wheel lug nuts or bolts to be sure none are loose or missing. Replace missing bolts or lug nuts. Torque loose or replaced items to specifications.

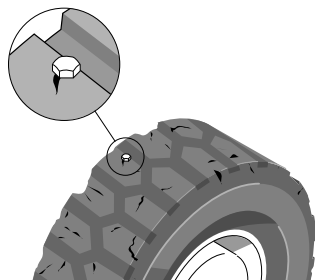

### WARNING

Check tire pressure from a position facing the tread of the tire, not from the side. Use a long-handled gauge to keep your body away from the side. If tires are low, do not operate and do not add air. Check with a mechanic. The tire may require removal and repair. Incorrect (low) tire pressure can reduce the stability of your lift truck. Do not operate truck with low tire pressure. For proper cold inflation pressure, check the CLARK specifications.

## Disassembling the Split Rim Wheel

When you disassemble the split-rim wheel, NEVER remove the tire before you deflate the tire pressure. First, deflate the tire pressure completely and then loosen the wheel bolts and nuts. Failure to do so could result in serious personal injury. This work should be performed only by a trained and authorized mechanic.

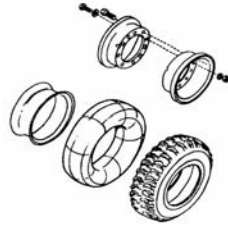

## Functional Tests

You will start the engine to complete the functional tests, so be sure that:

- The automatic parking brake is applied.
- Directional control is in NEUTRAL.
- Forks are fully lowered to the floor or ground
- All controls are in neutral or other correct position
- You are familiar with the safety procedures given in Section 4, "Operating Procedures," in this manual.

As you test the following components, be sure they are properly mounted and working correctly.

## Horn

Press the horn button to check horn function. If the horn or any other part does not operate, report the failure and have it repaired before the truck is put into operation.

## Neutral Start Switch

Check the operation of the neutral start switch by placing the direction control lever in FORWARD or REVERSE and turning the key switch to START position. The starter must not engage until the direction control lever is moved to the NEUTRAL position.

## Hour Meter

Start the engine and let it warm up until it runs evenly and accelerates smoothly when you push on the accelerator pedal. Check the hour meter for operation with the engine running. Write the hour meter reading on the PM report form. Report any malfunction or damage.

## Indicator Lights

Check that all lights are functioning and indicate normal truck operation as described in Section 3, "Operator Compartment and Controls," in this manual.

## Service Brakes and Inching Pedal

With the direction control in NEUTRAL and the engine running, push the service brake pedal fully down and hold. The brakes should apply before the pedal reaches the floorplate. If the pedal continues to creep downward, report the failure immediately. **Do not operate the truck until the brakes are repaired.** Perform the same check with the inching pedal. (Additional braking/inching checks will follow.)

## Parking Brake

Check the function of the parking brake. To check parking brake holding capability, park the lift truck on a grade and apply the parking brake. The parking brake should hold a lift truck with rated load on a 15% grade.

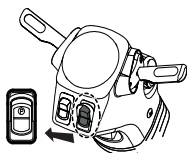

### CAUTION

**Do not operate a lift truck if the service or parking brakes are not operating properly.**

## Lift Mechanisms and Controls

Pull back on the tilt control lever and hold until the upright reaches the full back tilt position. Push forward on the lever to return the upright to the vertical position. Release the lever.



### CAUTION

**Be sure that there is adequate overhead clearance before raising the upright.**

Pull back on the lift control lever and raise the fork carriage to full height. Watch the upright assembly as it rises. Release the lever.

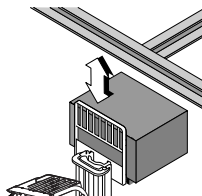

If the maximum fork height is not reached, this indicates there is an inadequate (low) oil level in the hydraulic sump tank or severe binding within the upright.

Push forward on the lift control lever. Watch the upright as it lowers. When the forks reach the floor, release the lever.

All movements of the upright, fork carriage, and lift chains must be even and smooth, without binding or jerking. Watch for chain wobble or looseness; the chains should have equal tension and move smoothly without noticeable wobble.

### Auxiliary Controls (Optional)

If your lift truck is equipped with an attachment, test the control lever for correct function and briefly operate the attachment.

### Steering System

#### NOTICE

**The steering system, steer axle, and steering linkage on your truck should be inspected periodically for abnormal looseness and damage, leaking seals, etc. Also, be alert for any changes in steering action. Hard steering, excessive freeplay (looseness), or unusual sound when turning or maneuvering indicates a need for inspection or servicing.**

Check the steering system by moving the steering handwheel in a full right turn and then in a full left turn. Return the handwheel to the straight-ahead position. The steering system components should operate smoothly when the handwheel is turned. **Never operate a truck that has a steering system fault.**



#### WARNING

**Fasten your seat belt before driving the truck.**

### Direction Control, Braking, and Inching

Be sure that the travel area is clear in front of the truck.

1. Push firmly on the brake pedal. Move the directional control lever from NEUTRAL to FORWARD.





2. Remove your right foot from the service brake pedal and put it on the accelerator pedal. Push down until the truck moves slowly forward. Remove your foot from the accelerator pedal and push down on the service brake pedal to stop the truck. The brakes should apply smoothly and equally.

Be sure the travel area is clear behind the truck.

3. Put the directional control lever in the REVERSE travel position. Release the service brake and push down on the accelerator pedal until the truck moves slowly in the reverse direction. Remove your foot from the accelerator pedal and push down on the service brake pedal to stop the truck. The brakes should apply smoothly and equally.
4. Put the directional control in FORWARD. Press the inching pedal fully down and hold. Depress the accelerator. The truck should not move. Now, with the accelerator still depressed, slowly release the inching pedal until the truck “inches” forward smoothly and slowly.

Report any problems.

When you have completed the operational tests, park and leave the truck according to standard shut down procedure as described in Section 4 of this manual. Be sure to make a record of all maintenance and operating problems you find.

### Fluids, Filters and Engine Accessories

To check fluid levels and other components within the engine compartment, unlatch and open the hood to access the engine compartment.



#### **CAUTION**

**To avoid the possibility of personal injury, never work in the engine compartment with the engine running, except when it is absolutely necessary to check or make adjustments. Take extreme care to keep hands, tools, loose clothing, etc., away from fan and drive belts. Also remove watches, bracelets, and rings. Use extreme care as hot surface may be present. The hood is the primary guarding for these dangers.**

## Engine Accessories

Inspect the engine coolant hoses and fan belt(s). Look for leaking and obvious damage, worn (frayed) condition, breaks, etc. that could cause failure during operation.

## Engine Air Cleaner

Check the engine air cleaner for damage and contamination (excessive dirt buildup and clogging). Be sure that the air cleaner hose is securely connected (not loose or leaking). Fan or cone shaped dust deposits on tube or hose surfaces indicate a leak.

Change or service the air cleaner element every 2000 operating hours for gas engine, every 1000 operating hours for diesel engine, depending upon your application. Service intervals may also be determined by the air restriction indicator.

## Battery

Inspect the battery for damage, cracks, leaking condition, etc. If the terminals are corroded, clean and protect them with CLARK Battery Saver (available from your CLARK dealer). If your battery has removable cell caps, check to be sure the cells are all filled. Refill them with distilled water.



### **WARNING**

**EXPLOSIVE GASES: Do not smoke or have open flames or sparks near batteries. An explosion can cause injury or death.**

## Engine Cooling System

To check engine coolant level open the hood to the engine compartment. Visually inspect the recovery bottle, locate the "HOT" and "COLD" marks. The "HOT" mark indicates maximum level at operating temperature. The "COLD" mark indicates additional coolant needs to be added to the system.

The recovery bottle shown is a typical illustration of overflow system. Your actual system may vary slightly.

A level anywhere between the FULL and LOW marks is normal.

Inspect the coolant level in the overflow bottle only.

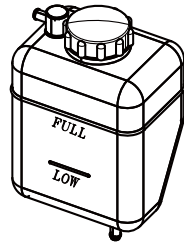

### WARNING

Do not remove the radiator cap when the radiator is hot. STEAM from the radiator will cause severe burns. Do not remove the radiator cap to check the coolant level.



### WARNING

Never remove the radiator cap while the engine is running. Stop the engine and wait until it has cooled. Failure to do so could result in serious personal injury from hot coolant or steam blowout and/or damage to the cooling system or engine.

If the level is low, add a 50/50 mixture of specified coolant and water to the correct fill level. If you have to add coolant more than once a month or if you have to add more than one litre at a time, check the coolant system for leaks.

- Check engine oil for presence of coolant leaking into engine.
- Inspect the coolant for condition. Look for excessive contamination or rust or oil in the coolant solution.
- Check the PM time interval for need to change coolant.
- Check the condition of radiator cap rubber seal and radiator filler neck for damage. Be sure they are clean.
- Check overflow hose for clogging or damage.

## NOTICE

Your lift truck cooling system is filled with a factory-installed solution of 50% water and 50% permanent-type antifreeze containing rust and corrosion inhibitors. You should leave the solution in year around. Plain water may be used in an emergency, but replace it with the specified coolant as soon as possible to avoid damage to the system. Do not use alcohol or methanol antifreeze.

## Engine Oil and Filter

Locate the engine oil dipstick. Pull the dipstick out, wipe it with a clean wiper, and reinsert it fully into the dipstick tube. Remove the dipstick and check oil level.

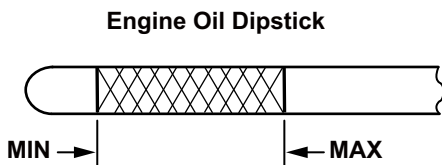

It is normal to add some oil between oil changes. Keep the oil level between the MIN and MAX marks on the dipstick by adding oil as required. Do not overfill. Use the correct oil as specified under Engine Oil Recommendations.

It is recommended to:

- Drain and replace the engine crankcase oil every 500 operating hours. (depending on application). Contact your nearest CLARK Dealer for further information.
- Engine Oil Filter must be changed at every PM when the oil is changed.
- Remove the oil pan drain plug to drain old oil after the truck has been in operation and the engine (oil) is at operating temperature.



## WARNING

**Engine oil at operating temperature is hot and can cause burns. Beware of splashing oil.**

- Carefully check for leaks after changing oil and installing new filter.

### NOTICE

The time interval for changing engine oil depends upon your application and operating conditions. To determine the correct schedule for your truck, it is suggested that you periodically submit engine oil samples to a commercial laboratory for analysis of the condition of the oil. This analysis can be used to reduce time intervals but not increase them.

Engine Oil Performance Designation

: Refer to the “*Engine Oil*” in Section 8.

### Hydraulic Sump Tank

Check the hydraulic sump tank fluid level. Correct fluid level is important for proper system operation. Low fluid level can cause pump damage. Overfilling can cause loss of fluid or lift system malfunction.

Hydraulic fluid expands as its temperature rises. Therefore, it is preferable to check the fluid level at operating temperature (after approximately 30 minutes of truck operation). To check the fluid level, first park the truck on a level surface and block the drive wheels. Put the upright in a vertical position and lower the fork carriage fully down. Pull the dipstick out, (attached to the sump breather) wipe it with a clean wiper, and reinsert it. Remove dipstick and check oil level. Keep the oil level above the LOW mark on the dipstick by adding recommended hydraulic fluid only, as required. **Do not overfill.**

Check the condition of the hydraulic fluid (age, color or clarity, contamination). Change (replace) the oil as necessary.

### Hydraulic Fluid and Filter Change

Drain and replace the hydraulic sump fluid every 2000 operating hours. (Severe service or adverse conditions may require more frequent fluid change). Replace the hydraulic oil filter elements at every oil change. Remove, clean, and reinstall the hydraulic and steer system suction line screens at time of fluid change. Check for leaks after installation of the filters. Also, check that the hydraulic line connections at the filter adapter are tightened correctly. The procedure for draining hydraulic sump tank is in your Service Manual.

## NOTICE

Your lift truck cooling system is filled with a factory-installed solution of 50% water and 50% permanent-type antifreeze containing rust and corrosion inhibitors. You should leave the solution in year around. Plain water may be used in an emergency, but replace it with the specified coolant as soon as possible to avoid damage to the system. Do not use alcohol or methanol antifreeze.

## Engine Oil and Filter

Locate the engine oil dipstick. Pull the dipstick out, wipe it with a clean wiper, and reinsert it fully into the dipstick tube. Remove the dipstick and check oil level.

It is normal to add some oil between oil changes. Keep the oil level above the ADD mark on the dipstick by adding oil as required. Do not overfill. Use the correct oil as specified under Lubricant Specifications.

It is recommended to:

- Drain and replace the engine crankcase oil every 500 operating hours. (depending on application). Contact your nearest CLARK Dealer for further information.
- Engine Oil Filter must be changed at every PM when the oil is changed.
- Remove the oil pan drain plug to drain old oil after the truck has been in operation and the engine (oil) is at operating temperature.



## WARNING

**Engine oil at operating temperature is hot and can cause burns. Beware of splashing oil.**

- Carefully check for leaks after changing oil and installing new filter.

## NOTICE

The time interval for changing engine oil depends upon your application and operating conditions. To determine the correct schedule for your truck, it is suggested that you periodically submit engine oil samples to a commercial laboratory for analysis of the condition of the oil. This analysis can be used to reduce time intervals but not increase them.

Engine Oil Performance Designation

*: Refer to the “Engine Oil” in Section 8.*

## Hydraulic Sump Tank

Check the hydraulic sump tank fluid level. Correct fluid level is important for proper system operation. Low fluid level can cause pump damage. Overfilling can cause loss of fluid or lift system malfunction.

Hydraulic fluid expands as its temperature rises. Therefore, it is preferable to check the fluid level at operating temperature (after approximately 30 minutes of truck operation). To check the fluid level, first park the truck on a level surface and block the drive wheels. Put the upright in a vertical position and lower the fork carriage fully down. Pull the dipstick out, (attached to the sump breather) wipe it with a clean wiper, and reinsert it. Remove dipstick and check oil level. Keep the oil level above the LOW mark on the dipstick by adding recommended hydraulic fluid only, as required. **Do not overfill.**

Check the condition of the hydraulic fluid (age, color or clarity, contamination). Change (replace) the oil as necessary.

## Hydraulic Fluid and Filter Change

Drain and replace the hydraulic sump fluid every 2000 operating hours. (Severe service or adverse conditions may require more frequent fluid change). Replace the hydraulic oil filter elements at every oil change. Remove, clean, and reinstall the hydraulic and steer system suction line screens at time of fluid change. Check for leaks after installation of the filters. Also, check that the hydraulic line connections at the filter adapter are tightened correctly. The procedure for draining hydraulic sump tank is in your Service Manual.



## Sump Tank Breather Maintenance and Inspection

Remove the sump tank fill cap/breather and inspect for excessive (obvious) contamination and damage. Replace the fill cap/breather, per recommended PM schedule or as required by operating conditions.

## Transmission Fluid Check

Before checking, run the engine until the unit is at operating temperature. This is important since transmission oil temperature should be  $65^{\circ}\text{C}\sim 120^{\circ}\text{C}$  ( $150^{\circ}\text{F}\sim 250^{\circ}\text{F}$ ), the engine should also be at operating temperature. Block the drive wheels.

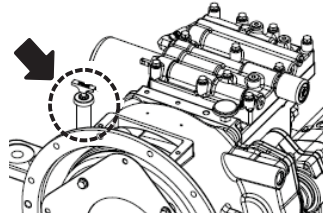

With the engine operating at idle the transmission in NEUTRAL and the drive wheels blocked, check the fluid on the dipstick. Fill, if necessary, to the FULL mark on the dipstick, using CLARK transmission fluid (Mobil 424, US market). If unable to determine actual oil temperature, use this alternate check method: With the unit cold, start and run the engine at idle for 30 seconds then check the level and fill only to the ADD mark.

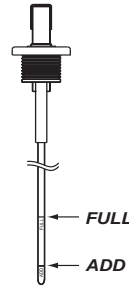

### NOTICE

**Check the planned maintenance interval (operating hours) or the condition of the oil to determine if the transmission fluid needs to be changed.**

## Drive Axle fluid check

### CAUTION

**Check the planned maintenance interval (operating hours) or the condition of the oil to determine if the drive axle fluid needs to be changed.**



Park the forklift truck on level ground, incline the mast forward to the largest extent, and check oil level of the drive axle.

When the oil temperature is same as the ambient temperature, make up the oil up to "LOW" mark on the oil level gauge. When filling oil up to "FULL" mark at temperature beyond engine running temperature, oil may overflow.

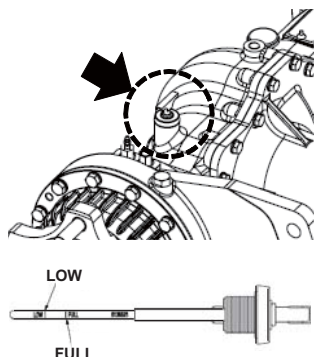

## Lubrication

### Truck Chassis Inspection and Lubrication

Lubrication and inspection of truck chassis components, including steer wheels, steer axle linkage, steering cylinder, and wheel bearings are easier if the truck is raised and blocked up under the frame. Refer to your Service Manual for additional information on machine blocking and jacking. Also refer to Service Manual for the location of grease fittings.



#### WARNING

**Do not raise the truck by lifting under the counterweight.**

Inspect the steering cylinder piston rods, seals, and fasteners for damage, leaks, and looseness. Lubricate the steer axle linkage rod ends and linkage pivot points. Be sure to clean the grease fittings before lubricating, and remove the excess grease from all points after lubricating. Lubricate miscellaneous linkage as needed.

### Upright and Tilt Cylinder Lubrication

Clean the fittings and lubricate the tilt cylinder rod end bushings (forward end) and both the base rod-end bushings (rear end). Clean and lubricate the upright trunnion bushings.

## Lift Chains

Lubricate the entire length of the upright rail lift and carriage chains with CLARK Chain and Cable Lube.

### **IMPORTANT**

**Do not lubricate the carriage roller rails.**

## Air Cleaning

Always maintain a lift truck in a clean condition. Do not allow dirt, dust, lint, or other contaminants to accumulate on the truck. Keep the truck free from leaking oil and grease. Wipe up all oil spills. Keep the controls and floorboards clean, dry, and safe. A clean truck makes it easier to see leakage and loose, missing, or damaged parts, and helps prevent fires. A clean truck runs cooler. The environment in which a lift truck operates determines how often and to what extent cleaning is necessary.

For example, trucks operating in manufacturing plants that have a high level of dirt, dust, or lint (for example, cotton fibers or paper dust) in the air or on the floor or ground, require more frequent cleaning. The radiator especially may require daily air cleaning to ensure correct cooling. If air pressure does not remove heavy deposits of grease, oil, etc., it may be necessary to use steam or liquid spray cleaner.

### **IMPORTANT**

**Lift trucks should be air cleaned at every PM interval, or more often if necessary.**

Use an air hose with special adapter or extension, a control valve, and a nozzle to direct the air properly. Use clean, dry, low pressure, compressed air. Restrict air pressure to 207 kPa (30 psi), maximum. (OSHA requirement.)



### **CAUTION**

**Wear suitable eye and breathing protection and protective clothing when air cleaning. Never point the air nozzle at anyone.**

Air clean the upright assembly, drive axle, radiator—from both counterweight and engine side, engine and accessories, driveline and related components, and steer axle and cylinder.

### Critical Fastener Torque Checks

Fasteners in highly loaded (critical) components can quickly fail if they become loosened. Also, loose fasteners can cause damage or failure of the component. For safety, it is important that the correct torque be maintained on all critical fasteners of components that directly support, handle, or control the load and protect the operator.

Critical items include:

- Drive axle mounting
- Overhead guard
- Drive and steer wheel mounting
- Tilt cylinder mounting and yokes
- Counterweight mounting
- Upright mounting and components

**Torque specifications are in Service Manual.**

### Lift Chain Maintenance

The chain system on the upright was designed for safe, efficient, and reliable transmission of lifting force from hydraulic cylinder to the forks. Safe use of your truck with minimum down-time depends on the correct care and maintenance of the lift chains. Most complaints of unacceptable chain performance are a result of poor maintenance. Chains need periodic maintenance to give maximum service life.



#### **WARNING**

**Do not attempt to repair a worn chain. Replace worn or damaged chains in pairs. Do not piece chains together.**

## Lift Chain Inspection and Measurement

Inspect and lubricate the lift chains every PM (500 hours). When operating in corrosive environments, inspect the chains every 50 hours. During the inspection, check for the following conditions:

- Rust and corrosion, cracked plates, raised or turned pins, tight joints, wear, and worn pins or holes.
- When the pins or holes become worn, the chain becomes longer. When a section of chain is 3% longer than a section of new chain, the chain is worn and must be discarded.
- Chain wear can be measured by using a chain scale or a steel tape measure. When checking chain wear, be sure to measure a segment of chain that moves over a sheave. Do not repair chains by cutting out the worn section and joining in a new piece. If part of a chain is worn, replace all the chains on a truck.

## Lift Chain Lubrication

Lift chain lubrication is an important part of your maintenance program. The lift chains operate under heavy loadings and function more safely and have longer life if they are regularly and correctly lubricated. CLARK chain lubricant is recommended; it is easily sprayed on and provides superior lubrication. Heavy motor oil may also be used as a lubricant and corrosion inhibitor.

### Lift Chain Wear and Replacement Criteria:

1. (NEW CHAIN LENGTH) The distance from the first pin counted to the last pin counted in a span while the chains are lifting a small load.
2. (WORN CHAIN LENGTH) The distance from the first pin counted to the last pin counted in a span while the chains are lifting a small load.
3. (SPAN) The number of pins in the length (segment) of chain to be measured.
4. (PITCH) The distance from the center of one pin to the center of the next pin.

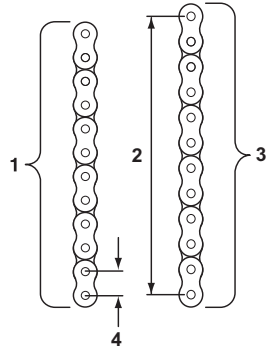

All chains must be replaced if any link has wear of 3% or more, or if any of the damaged conditions noted above are found during inspection. Order replacement chains from your CLARK dealer. Replace all chains as a set. Do not remove factory lubrication or paint new chains. Replace anchor pins and worn or broken anchors when installing new chains. Adjust tension on new chains. Lubricate chains when they are installed on the upright.

#### NOTICE

**Please refer to your Service Manual for additional information on lift chain measurement and maintenance.**



# Specifications

## Contents

S20-35, S20-32C ..... 8-2

Engine Oil ..... 8-6



## S20-35, S20-32C

CLARK products and specifications are subject to improvements and changes without notice or obligation.

### Model Designation - Rated Load Capacity

S20 D/L/G	1810kg@600mm load center [4000lbs@24in] [2000kg@500mm]
S25 D/L/G	2270kg@600mm load center [5000lbs@24in] [2500kg@500mm]
S30 D/L/G	2720kg@600mm load center [6000lbs@24in] [3000kg@500mm]
S35 D/L/G	3175kg@600mm load center [7000lbs@24in] [3500kg@500mm]
S20C L/G	1810kg@600mm load center [4000lbs@24in] [2000kg@500mm]
S25C L/G	2270kg@600mm load center [5000lbs@24in] [2500kg@500mm]
S30C L/G	2720kg@600mm load center [6000lbs@24in] [3000kg@500mm]
S32C L/G	2950kg@600mm load center [6500lbs@24in] [3200kg@500mm]

### NOTICE

**Rated capacity applies when using standard upright and forks. [S20-30(C):3300mm, S32C:3165mm, S35:3165mm MFH]**

### Engine

Specifications for EPA engine (S20-35, S20-32C)

	Diesel (Tier3)	Diesel (Tier4)	LPG/Gas (Tier0)	LPG/Gas (Tier4)	LPG/Gas (Tier0, 4)
Model :	YANMAR 4TNE98	ISUZU 4LE2X	PSI 4G64	FORD 2.5L	HMC THETA
Cylinders :	4	4	4	4	4
Displacement cubic inches :	202	133	143	152	143
liters :	3.3	2.2	2.4	2.5	2.4
Idle RPM :	850	800	800	750	800
Governed RPM					
High idle :	2725	2650	2650	2500	2500
Rated RPM :	2300	2400	2650	2500	2500
Rated kW :	44.3	46.0	51.6	51.5	48.7



## Cooling System

Automotive type crossflow radiator.

Cooling system pressure (radiator cap): 88 kPa nominal, 12.8psi

Thermostat: Diesel, 82°C (180°F), fully open 95°C (200°F),  
Gas/LPG 82°C (180°F), fully open 95°C (200°F)

## Power Train (Transmission / Drive Axle)

### Forklift truck with Yanmar, Isuzu, PSI, Ford engine

- Gear Ratio
  - Pneumatic truck : 1.16
  - Cushion truck : 0.9818
  - Drive Axle : 14.2
  - Total :
    - Pneumatic truck : 16.472
    - Cushion truck : 13.942
- Torque Converter Stall Ratio : 3.3
- Differential : 4-Pinion
- Brake (Service / Parking) : Wet disk brake

### Forklift truck with HMC THETA engine

- Transmission Gear Ratio : 1.205
- Torque Converter Stall Ratio : 2.87
- Drive Axle
  - Bevel gear : 2.462
  - Planetary reduction : 5.769
  - Total : 14.2
- Differential : 4-Pinion
- Brake (Service / Parking) : Wet disk brake

## Wheels and Tires

Drive	S20-25	7.0x12-14PR.....	895kPa (130psi)
		7.0x12-14PR (MITCO).....	1000kPa (145psi)
	S30	28x9x15-14PR.....	1000kPa (145psi)
		28x9x15-14PR (MITCO).....	1050kPa (152psi)
	S30 Dual	7.0x12-14PR.....	895kPa (130psi)
		7.0x12-14PR (MITCO).....	1000kPa (145psi)
	S35	250x15-18PR.....	965kPa (140psi)
		250x15-20PR (MITCO).....	1000kPa (145psi)
	S35 Dual	28x9x15-14PR.....	1000kPa (145psi)
		28x9x15-14PR (MITCO).....	1050kPa (152psi)
	S20-25C	21x7x15	
	S30C	21x8x15	
S32C	21x9x15		
Steer	S20-25	6.0x9-12PR.....	1000kPa (145psi)
		6.5x9-14PR (MITCO).....	1050kPa (152psi)
	S30 Dual	6.5x10-14PR.....	1000kPa (145psi)
		6.5x10-14PR (MITCO).....	1050kPa (152psi)
	S30-35	6.5x10-14PR.....	1000kPa (145psi)
		6.5x10-14PR (MITCO).....	1000kPa (145psi)
	S20-25C	16x5x10.5	
	S30-32C	16x6x10.5	

## Electrical System Specifications

Type: 12 volt DC, negative ground      Fuses: 10, 15 amps

**Batteries: BCI Group 45**

## Fuel Recommendations

Diesel: D-2 with cetane rating of 45 or higher.  
D-1 and Jet A-1 also acceptable.

Gasoline: 87 octane minimum      LPG: HD-5 propane

## Engine Coolant Recommendation

Use a mixture of 50% ethylene glycol permanent-type anti-freeze containing rust and corrosion inhibitor only.

**NOTICE**

**This mixture provides anti-freeze protection level of -37°C (-34°F), approximately.**

**Transmission Fluid Recommendation\***

Use CLARK Specification TEXTRAN TDH CLARK Part number 2776236.

**Drive Axle Fluid Recommendation\***

Use CLARK Specification MOBIL Fluid #424 CLARK Part number 1809371.

**\*On US market trucks with forced cooling, the Drive Axle and the Transmission share common fluid and Mobil 424 must be used.**

**Hydraulic Fluid Recommendation**

Use CLARK Specification MS-68 CLARK Part number 2776239 Hydraulic Oil, with anti-wear additives, or equivalent only.

**Fill Capacities** (*fluid volumes-liters, quarts, gallons, kilogram, pound*)

Model	Cooling system	Eng.oil, w/filter**	T/Mission*	Drive axle*	Hydraulic sump	Fuel tank
S20-25D	9.6L[10.1Q]	8.4L[8.8Q]	10.0L[10.6Q]	4.1L[4.3Q]	47L[12.4G]	64L[67.6Q]
S30-35D	9.6L[10.1Q]	8.4L[8.8Q]	10.0L[10.6Q]	4.1L[4.3Q]	47L[12.4G]	68L[71.9Q]
S20-25L	8.5L[9.0Q]	6.4L[6.7Q]	10.0L[10.6Q]	4.1L[4.3Q]	47L[12.4G]	15kg[33 lb]
S30-35L	8.5L[9.0Q]	6.4L[6.7Q]	10.0L[10.6Q]	4.1L[4.3Q]	47L[12.4G]	15kg[33 lb]
S20-25G	8.5L[9.0Q]	6.4L[6.7Q]	10.0L[10.6Q]	4.1L[4.3Q]	47L[12.4G]	64L[67.6Q]
S30-35G	8.5L[9.0Q]	6.4L[6.7Q]	10.0L[10.6Q]	4.1L[4.3Q]	47L[12.4G]	68L[71.9Q]
S20-32CL	10.5L[11.1Q]	6.4L[6.7Q]	10.0L[10.6Q]	4.1L[4.3Q]	40L[10.6G]	15kg[33 lb]
S20-32CG	10.5L[11.1Q]	6.4L[6.7Q]	10.0L[10.6Q]	4.1L[4.3Q]	40L[10.6G]	59L[62.3Q]

\*On US market trucks with forced cooling, the Drive Axle and the Transmission share common fluid and the amounts must be combined for total capacity of the Transmission/ Drive Axle fluid system. Fill the system until the transmission dipstick reads within the safe operating range, with truck running at operating temp, the transmission in neutral and drive wheels blocked.

\*\*Capacity for US market trucks with FORD (5.4L[5.7Q]), ISUZU (8.4L[8.8Q]), HMC (5.7L[6.0Q]) engines only.

**Truck Weights - with standard upright.****[S20-30(C):3300mm, S32C:3165mm, S35:3165mm MFH]**

	Gross Vehicle Weight(kg[lbs])	Empty Vehicle Weight (kg[lbs])	Loaded Drive Axle (kg[lbs])	Empty Drive Axle (kg[lbs])
<b>S20-35 Pneumatic Diesel</b>				
S20	5435 [11982]	3435 [7572]	4740 [10450]	1570 [3461]
S25	6274 [13831]	3774 [8320]	5463 [12043]	1501 [3309]
S30	7243 [15967]	4243 [9354]	6314 [13920]	1594 [3514]
S35	8150 [17967]	4650 [10251]	6830 [15057]	1598 [3523]
<b>S20-35 Pneumatic LPG &amp; GAS</b>				
S20	5340 [11772]	3430 [7363]	4806 [10595]	1636 [3606]
S25	6179 [13622]	3679 [8110]	5528 [12187]	1566 [3452]
S30	7149 [15760]	4149 [9146]	6373 [14050]	1653 [3644]
S35	8054 [17755]	4554 [10039]	7204 [15881]	1656 [3650]
<b>S20-32C Cushion LPG &amp; GAS</b>				
S20C	5430 [11971]	3430 [7562]	4658 [10269]	1387 [3058]
S25C	6302 [13894]	3802 [8382]	5370 [11839]	1280 [2822]
S30C	7219 [15915]	4219 [9301]	6188 [13642]	1281 [2824]
S32C	7628 [16817]	4428 [9762]	6526 [14387]	1281 [2824]

## Engine Oil

### Engine Oil Recommendations

#### LPG / GAS truck :

- Ford - in accordance with ILSAC classification more than a class GF-5 grade and SAE 5W-30 full synthetic
- PSI 4G64 - in accordance with API classification more than a class SM grade / SAE 10W-30, long drain.
- HMC THETA - in accordance with API classification more than a class SM grade / SAE 10W-30, long drain.

#### Diesel truck :

- Yanmar - in accordance with API classification CD or higher / SAE 10W-30  
in accordance with ACEA classification E-3, E-4, E5 / SAE 10W-30  
in accordance with JASO classification DH-1 / SAE 10W-30
- Isuzu - in accordance with API classification CJ-4 and ACEA E6,E9, JASO DH-2 / SAE 15W-40

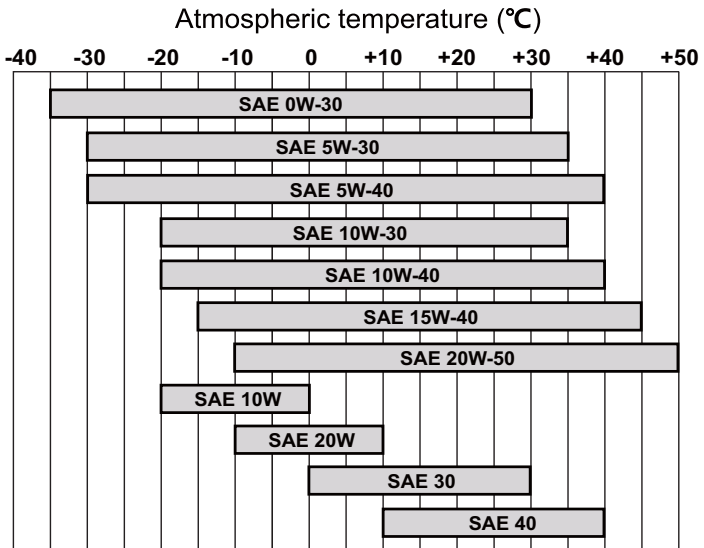

### **IMPORTANT**

**Do not extend oil change intervals from those specified when using synthetic lubricants. The Ford engine must be filled with full synthetic motor oil as specified on the previous page.**

Fill crankcase with correct amount of oil. When adding oil between oil changes, it is preferable to use the same brand as various oils may be incompatible. Refer to the Maintenance and Lubrication Section for recommended oil change intervals.

### **IMPORTANT**

**Do not overfill crankcase. Excess oil causes foaming and can cause loss of lubrication and higher operating temperatures, resulting in engine damage.**



# Index

## A

- A Message to CLARK Lift Truck Operators ..... ii
- Adjusting the Load Forks ..... 4-10
- Adjusting the Seat ..... 4-4
- After Operating the Truck ..... 4-16
- Air Cleaning ..... 7-27
- Attached position of safety decals ..... 3-56
- Auto Choke Control (Gasoline Only) ..... 3-45
- Auxiliary Control Lever (Optional) ..... 3-44
- Auxiliary Controls (Option) ..... 7-20

## B

- Battery ..... 7-22
- Before Operating the Truck ..... 4-2
- Brake Pedals ..... 3-43
- Braking ..... 4-6
- Buckling Up ..... 4-4

## C

- Chain Slack ..... 2-7
- Changing the engine oil and filter ..... 7-4
- Cold Start Preheating (Diesel Only) ..... 3-41
- Concluding the Inspection ..... 5-4
- Controlling Speed ..... 4-6
- Cooling System ..... 8-3
- Critical Fastener Torque Checks ..... 7-28

## D

- Daily Inspection ..... 1-2
- Daily Safety Inspection ..... 5-2
- Direction Control Lever ..... 3-43
- Direction Control, Braking, and Inching ..... 7-20
- Disassembling the split rim wheel ..... 7-18
- Display ..... 3-6

- Display monitoring ..... 3-16
- Do's and Don'ts ..... 1-3
- Drop-Offs ..... 2-5

## E

- Engine ..... 8-2
- Engine Accessories ..... 7-22
- Engine Air Cleaner ..... 7-22
- Engine Coolant Recommendation ..... 8-5
- Engine Cooling System ..... 7-22
- Engine Oil ..... 8-6
- Engine Oil and Filter ..... 7-24
- Engine Oil Recommendations .. 8-6
- Engine Stop ..... 3-41
- Error Codes ..... 3-28
- Extreme Operation ..... 7-9

## F

- Fill Capacities ..... 8-5
- Fluids, Filters, and Engine Accessories ..... 7-21
- Fork Safety ..... 1-8
- Forks ..... 7-16
- Fuel Recommendations ..... 8-4
- Fuel Safety Practices ..... 5-5
- Functional Checks ..... 5-4
- Functional Tests ..... 7-18
- Fuse ..... 3-49

## G

- General Tire Maintenance, Inspection, and Repair ..... 1-16
- Grades, Ramps, Slopes, and Inclines ..... 1-11

## H

- Heater and Air conditioner ..... 3-51
- Hood open ..... 3-48
- Horn ..... 7-18
- Horn Button ..... 3-43
- Hour Meter ..... 3-43
- Hour Meter ..... 7-18

How to Perform Planned Maintenance .....	7-14
How to Tow a Disabled Truck ...	6-2
How to Use Battery Jumper	
Cables .....	6-7
How to Use this Manual .....	viii
Hydraulic Control Levers .....	3-44
Hydraulic Fluid and Filter	
Change .....	7-25
Hydraulic Fluid	
Recommendation .....	8-4
Hydraulic Sump Tank .....	7-25
<b>I</b>	
Indication of Display .....	3-8
Indicator Lights .....	7-19
Instrument Pod .....	3-4
Introduction .....	vi
Introduction .....	7-2
<b>K</b>	
Keep Away from Forks	
Decal .....	3-55
Key/Start Switch .....	3-41
<b>L</b>	
Lateral Tip-over .....	1-13
Lift Chain Inspection and	
Measurement .....	7-29
Lift Chain Lubrication .....	7-29
Lift Chain Maintenance .....	7-29
Lift Chain wear and	
Replacement Criteria .....	7-30
Lift Chains .....	7-27
Lift Control Function .....	3-44
Lift Mechanisms and	
Controls .....	7-19
Load Backrest .....	7-15
Load Handling .....	4-11
Load Handling Components ...	7-15
Long and Wide Loads /	
Rear Swing .....	2-3
Longitudinal Tip-over .....	1-13
Loose Loads .....	2-2
Low Overhead Clearance	
Fast Turns and High Loads ....	2-4
Lubrication .....	7-26

<b>M</b>	
Major Component Locations .....	7-8
Message Function .....	3-32
Mini Lever .....	3-46
Mode Select Switch .....	3-7
<b>N</b>	
Neutral Start Switch .....	7-18
No Riders .....	1-5
Normal Operation .....	7-9
<b>O</b>	
Operating Safely .....	4-7
Operator Compartment .....	3-3
Operator Daily Inspection .....	vii
Operator Protection .....	1-7
Operator Safety Warning	
Decal .....	3-54
Operator/Tip-Over .....	3-54
Overhead Guard .....	7-15
<b>P</b>	
Pallets and Skids .....	2-8
Password Setup .....	3-24
Parking .....	1-15
Parking Brake .....	3-42
Parking Brake .....	7-19
Pedestrians .....	1-6
Picking Up and Moving	
Loads .....	4-13
Pinch Points .....	1-9
Planned Maintenance .....	vii
Planned Maintenance	
Intervals .....	7-9
PM Report Form .....	7-12
Positioning Forks and Upright ...	4-5
Powertrain (TM and D/axle) .....	8-3
Preferred Method of Inching ...	3-48
<b>R</b>	
Refueling Gasoline and	
Diesel Trucks .....	5-5
Refueling LPG Tanks .....	5-6
Right-Angle Stacking .....	2-6
Right-Angle Stacking .....	2-6
Routine Servicing and	
Maintenance .....	vi



## **S**

Safe Maintenance Practices .....	7-3
Safety Signs and Safety Messages .....	x
Seat Adjustment .....	3-42
Seat Belts .....	1-4
Service Brakes and Inching Pedal .....	7-19
Stacking .....	4-14
Starting from a Safe Condition ...	4-3
Starting the Truck .....	4-4
Steering Column .....	3-48
Steering System .....	3-43
Severe Operation .....	7-9
Steering System .....	7-20
Sump Tank Breather Maintenance and Inspection .....	7-26
Surface and Capacity .....	1-12

## **T**

TFT LCD .....	3-6
Tilt Control Lever .....	3-44
Tip-Over .....	1-13
Traction Disable Function .....	3-44
Transmission and Drive axle Fluid Recommendation .....	8-4
Transmission Fluid Check .....	7-26
Travel .....	1-10
Traveling with a Load .....	4-12
Truck Chassis Inspection and Lubrication .....	7-26
Truck Data and Capacity Plate .....	3-53
Truck Description .....	3-2
Truck Weights .....	8-5

## **U**

Unloading .....	4-13
Upright and Tilt Cylinder Lubrication .....	7-27
Upright Warning Decal .....	3-55

## **V**

Visual Checks .....	5-3
Visual Inspection .....	7-14

## **W**

What to do in Case of a Tip-over .....	1-14
Wheels and Tires .....	7-17
Wheels and Tires .....	8-3