

# CLARK

**Industrial  
Truck  
Division**

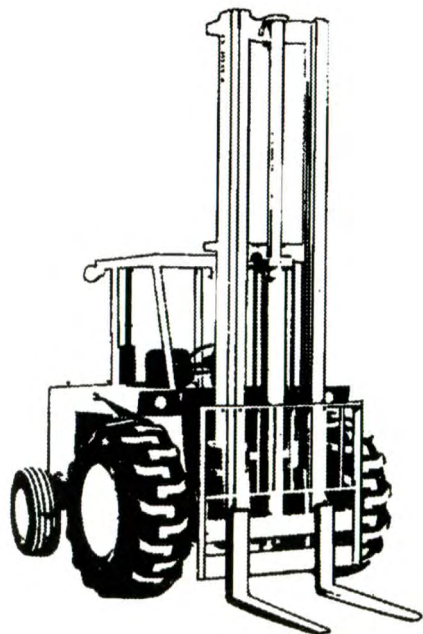

# OPERATOR INSTRUCTIONS

**UTILITY TRUCK  
UT 40D and UT 60D  
Diesel Powered**

BOOK NO. 01-375

**4000 LBS. AND 6000 LBS.  
RATED CAPACITIES**

 **WARNING**

- FOR YOUR SAFETY AND THE SAFETY OF OTHERS.
- BEFORE YOU OPERATE THIS TRUCK!
- READ ALL WARNINGS AND INSTRUCTIONS IN THE OPERATOR'S MANUAL AND ON THE TRUCK.
- CHECK THE TRUCK FOR CORRECT OPERATION.
- DO NOT OPERATE THIS TRUCK UNLESS YOU ARE TRAINED AND AUTHORIZED TO DO SO.

**IMPORTANT**

Do not expose this manual to hot water or steam.

The following warnings are provided pursuant to California Health & Safety Code Sections 25249.5 et. seq:

 **WARNING**

**California Proposition 65**

This product contains and emits chemicals known to the State of California to cause cancer, birth defects and other reproductive harm.

**CALIFORNIA**

**Proposition 65 Warning**

Diesel engine exhaust and some of its constituents are known to the State of California to cause cancer, birth defects or other reproductive harm.

 **WARNING**

The engine exhaust from this product contains chemicals known to the State of California to cause cancer, birth defects or other reproductive harm.

## TABLE OF CONTENTS

Foreword .....	Page 1
Major Component Identification .....	Page 2 & 3
Safe Operating Rules and Practices .....	Page 4-16
Operator's Compartment and Controls .....	Page 17
Operator's "Before Operation" Checks .....	Page 18-35
Operating Hints .....	Page 36-40
Fuel and Engine Oil Recommendations .....	Page 37-39
Cold Weather Starts .....	Page 41-42
Parking Procedures .....	Page 43
Other Things to Remember .....	Page 44
Handy Reference Data .....	Page 45



# FOREWORD

A large share of the total cost of most every product can be traced to handling. This includes in-plant transport, storage, freight, warehousing and final delivery. In many cases, the fork lift truck plays a key role in each of these operations.

You and your lift truck can significantly reduce these costs . . . or increase them. A lift truck costs thousands of dollars. Add to this the cost of operation (operator's pay, fuel, maintenance, fringe benefits, etc.) and it can easily be seen that this is an important investment for any company. The investment has now been made and it is up to you to ensure that maximum return is realized.

This manual will help the "Qualified Operator" become familiar with the lift truck's major components, its operating controls, special features and the function(s) of each.

This publication is not a training manual but rather, a guide to help the "Qualified Operator" to more safe and efficient operation of a Clark lift truck.

Operator training manuals are available through your Clark dealer.

Clark trucks are built to take hard work not abuse — they are built to be dependable, but — as with any other truck — they are only as good as the man behind the wheel and the men responsible for maintaining them.

This manual guides the operator through correct procedures for checking, starting, operating, stopping and parking the lift truck.

Read it, Study it, Keep it handy.

# Know Your Truck

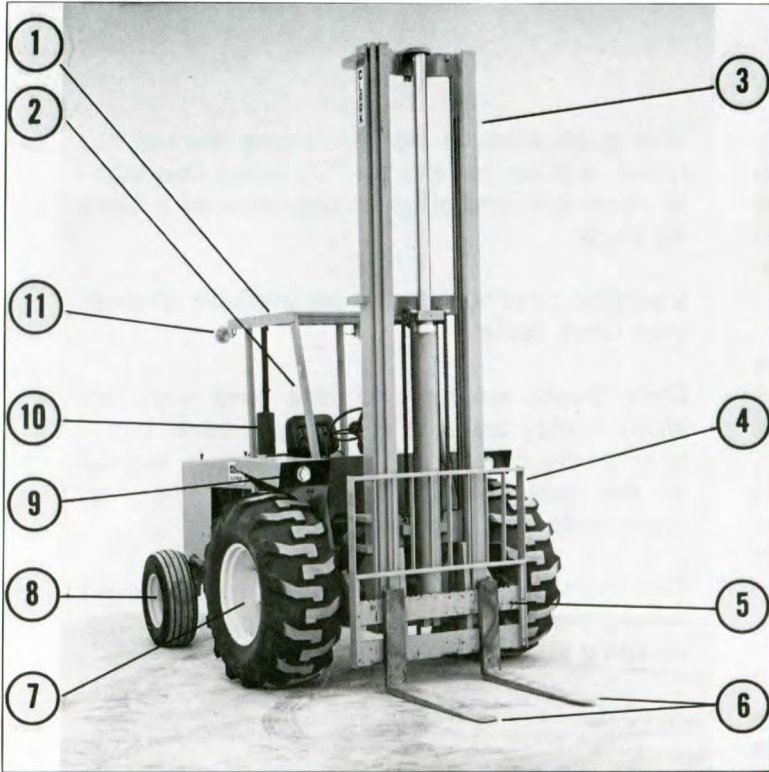

1. Overhead Guard
2. Operators Compartment
3. Upright Assembly
4. Load Backrest Extension
5. Lift Carriage Assembly
6. Load Forks
7. Drive Wheel and Tire
8. Steer Wheel and Tire
9. Headlight
10. Muffler and Vertical Exhaust System
11. Warning Lights

17422

**UTILITY TRUCK**  
**Model UT40D**  
**Diesel Powered**  
**4000 Lbs. Rated Capacity**

# Know Your Truck

1. Overhead Guard
2. Operators Compartment
3. Upright Assembly
4. Load Backrest Extension
5. Lift Carriage Assembly
6. Load Forks
7. Drive Wheel and Tire
8. Steer Wheel and Tire
9. Headlight
10. Muffler and Vertical Exhaust System
11. Warning Lights

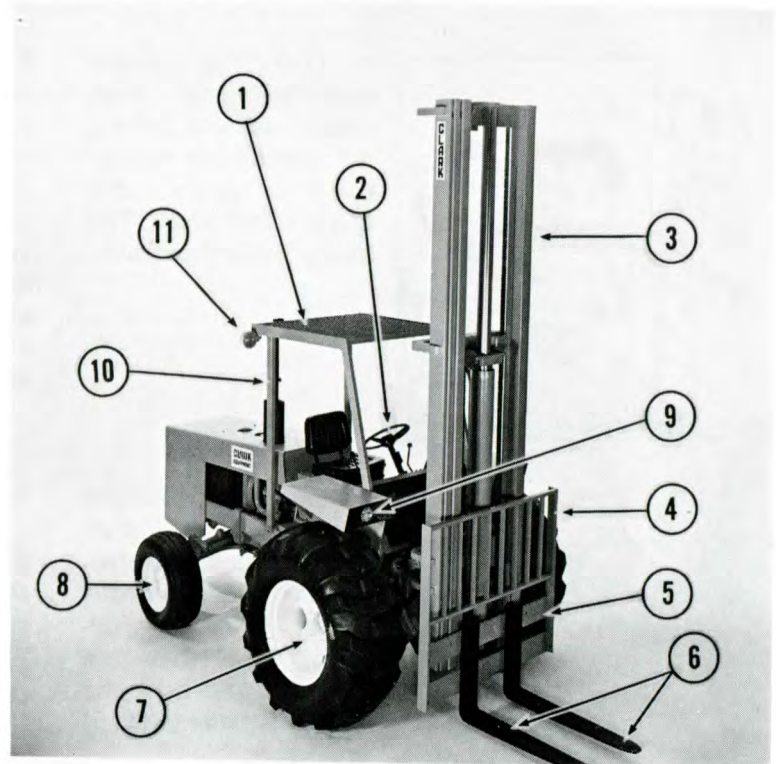

**UTILITY TRUCK**  
**Model UT60D**  
**Diesel Powered**  
**6000 Lbs. Rated Capacity**

17460

# Safety



13696  
16833

1. Only physically qualified and thoroughly trained personnel should be authorized to operate the Clark UT40 and UT60 model utility tractors.



3. Learn the location and the function of all your trucks instruments and controls. Know its safety devices, how they are operated and how the special attachments, if any, work.

2. Prominently placed on every Clark truck is a list of basic rules for operation. These rules are for the protection of you and others in your operating area. Be familiar with them and always operate your truck accordingly.



13110  
17449

4. The wearing of "hard hat", safety glasses and safety shoes is recommended. Dress suitably and avoid loose fitting clothing.





# Safety



16742  
16834

5. **NEVER** operate a lift truck with wet or greasy hands or shoes.

6. Before operating any lift truck, test the horn, service brakes, hand brake, steering, lift-tilt controls, directional controls and any special devices for proper operation. Report any improper operation to the proper authority.

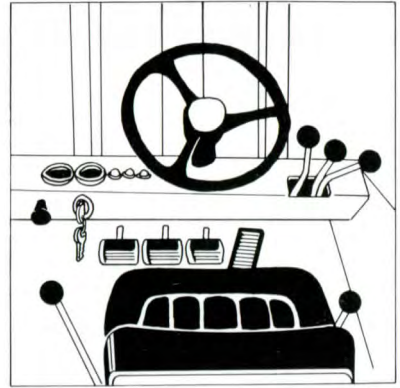

17450  
17451



7. Always look all around the truck before moving it in any direction. Then remember to start and stop slowly and smoothly.

8. Operate the truck only in designated truck routes and keep operating aisles clear. One-way traffic is recommended. If this is not practical in your operation heed highway regulations and drive to right of aisle centerline.

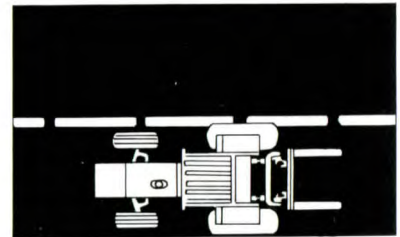
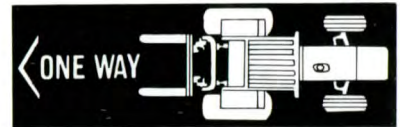

# Safety



16835  
13087

9. Be alert for pedestrians, other trucks or obstacles in your path of travel.

10. Sound horn at all corners, exits, entrances and when approaching pedestrians or bystanders.



13141  
17452

11. Obey all posted traffic rules and warning signs.

12. Maintain a safe distance from the truck ahead of you at all times.

Assure ample distance to stop smoothly and safely should the need arise.

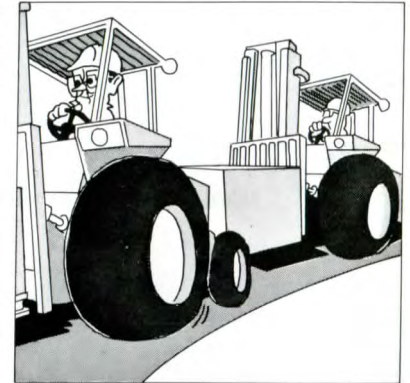

# Safety



17445  
17446



13. Be aware of rear end swing and be alert to prevent rear end swing damage to material in your operating area.

15. Be extremely cautious when operating truck near edge of loading dock, embankment, ditch or ramp.

14. Be aware of the position of your fork tips when the truck is in motion. Be alert to prevent striking anything with fork tips.

16. Make certain that vehicle being entered, loaded or unloaded has been blocked to prevent accidental roll.

Bridge plates, if used, must have adequate strength, width, guard rails, each side (minimum 3" high recommended) and be properly secured.



17421  
17447



# Safety

17. Never allow stunt riding or indulge in horseplay while operating a fork lift truck. This is dangerous and could result in serious injury to you and to other persons in your operating area.



17448  
17442

19. Never carry unauthorized passengers. The quick response of a lift truck may cause riders to fall off. Besides, they distract you and this is dangerous.



18. Never use your truck to push or tow another. Never allow your truck to be pushed or towed by another.



17441  
13095

20. Know the capacity of your truck and its attachment (if any) and never exceed it. Study your truck data capacity plate and learn the facts stamped in areas 1 through 8.

CLARK EQUIPMENT		1	
INDUSTRIAL TRUCK DIVISION	BATTLE CREEK MICH.		
MODEL NO.	2	TYPE	3
SERIAL NO.			
ATTACHMENTS		4	
LOAD C, G A B	CAPACITY WITH ATACH. LISTED ABOVE OR WITH FORKS - UPRIGHTS VERTICAL		
FLOOR	LBS	A	B C
APPROX. WT. ALL TRUCKS	5		
APPROX. WT. ELECTRICS ONLY	LESS BATT. - ELECTRICS		
BATTERY WT.	WITH MAX. BATT. WT.		
BATTERY	MAX	7	MIN
CAPACITY	A.M	VOLTS	
	LBS	8	
<small>FOR OTHER CAPACITIES CONSULT MANUFACTURER AS RELEASED FROM FACTORY THIS TRUCK MEETS THE DESIGN SPECIFICATIONS ESTABLISHED IN AMERICAN NATIONAL STANDARD FOR POWERED INDUSTRIAL TRUCKS. PART II, ANSI B 56 1-1969. P.T. NO. 2315709</small>			

# Safety



17444  
16836

21. Thoroughly inspect all loads to be moved for overload and/or poor balance. If the stability of a load is questionable, don't move it. If you are not certain that the load to be moved is within the safe rated capacity of your truck do not attempt to move it as one load.

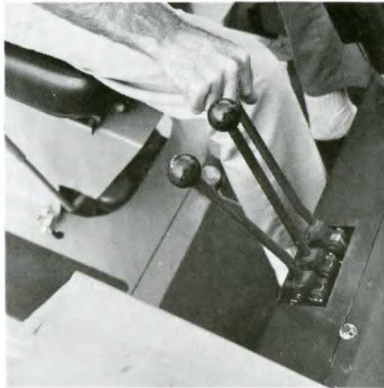

23. Always check to insure that you have adequate unobstructed overhead clearance before attempting to lift. Then gradually and smoothly pull back on lift control lever. Return the lever to neutral to stop lift at desired level.

22. Unstable loads are a hazard to you and to your fellow workers. Always make certain that your load is well stacked and evenly positioned across both forks. Never attempt to lift a load with only one fork.



17443  
16837

24. Make certain the area under the load or forks is clear and push forward on control lever to lower the load. Descent of the load may be stopped as desired by returning lever to neutral position.

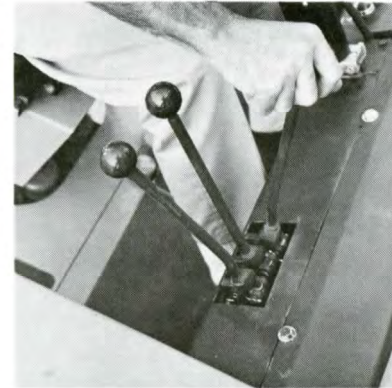

# Safety

25. Always travel with load NEAR the operating surface and upright tilted back to cradle your load.

Never lift or lower the load while your truck is in motion and remember to keep your load upright when operating on ramps or inclines.



17437  
16835

27. Remain seated at all times and keep head, hands, arms, feet and legs within the confines of the operator's compartment.

Never reach into the upright for any reason. Never climb on the upright or use it as a ladder.



26. Never permit anyone to stand or walk under elevated forks or other load engaging attachments if machine is so equipped.

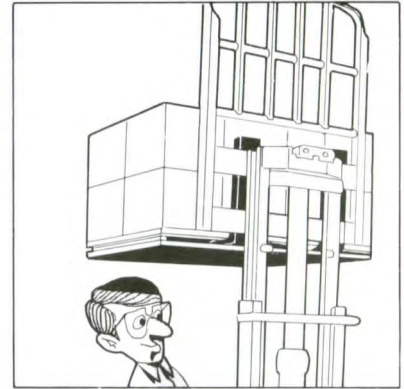

13522  
13103

28. Slow down for turns, ramps, bumps, cross aisles, wet or slippery operating surfaces and at all times when visibility is restricted.



# Safety



13102  
17438



Code: OI-375 Sep. 75

29. Know and observe all overhead clearances, floor and bridge load limits in your operating areas. Make sure floors of railroad cars, trucks, trailers and elevators are adequate before driving on them.

31. Lift trucks must be refueled in designated areas only. Engines must be stopped and "no smoking" regulations strictly enforced.

Spilled fuel must be washed away or completely evaporated and the fuel tank cap properly replaced before re-starting the engine.

30. Use caution when placing loads or traveling near water pipes, overhead sprinklers, electrical wiring, steam pipes, heaters or other fragile or dangerous equipment or material.

32. Never smoke or allow anyone to smoke in areas where batteries are being charged or in areas where fuels or other flammable fluids or materials are used or stored. Batteries must be charged in designated areas only and must be serviced only by thoroughly trained and qualified personnel.

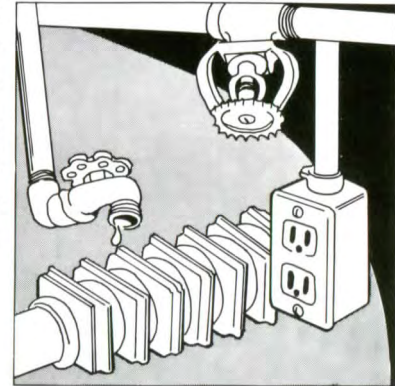

13104  
13107

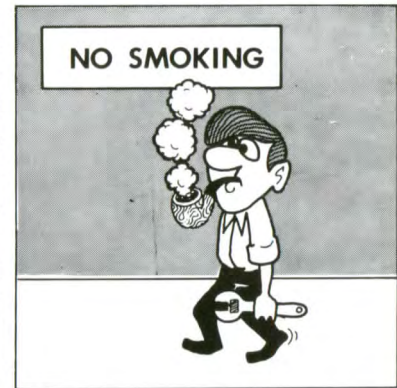

Page 11

# Safety

33. When handling bulky loads which, because of their size and shape, restrict your vision — operate your truck in reverse to improve visibility.

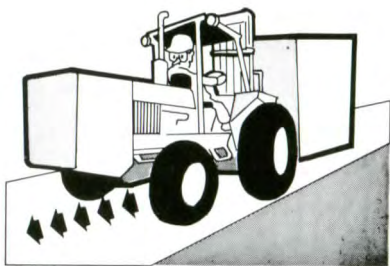

17439  
16777

34. Overloading is extremely dangerous. You don't have complete control of your truck and you are causing unnecessary wear.

Never add to your counterweight, always break down the load.



17440  
17433

35. Lift trucks are not designed as personnel elevators. If your truck must be used this way always use a properly designed safety platform securely attached to the forks.



36. Don't handle double tiered loads. They're unstable and difficult to control. Even an overhead guard can't fully protect you from heavy objects dropped from these heights.





# Safety

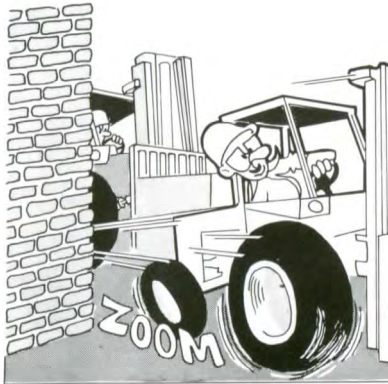

17434  
17436

37. Don't pass other trucks traveling in the same direction at intersections, blind spots or other dangerous locations.

38. Overhead guards and load backrest extensions are for your protection. Make certain they are securely mounted and undamaged before operating your truck.

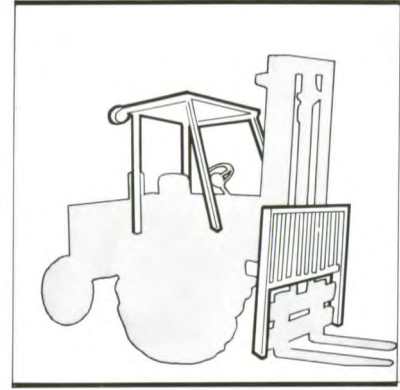

17435  
17429

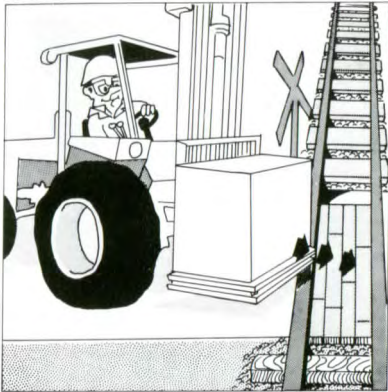

39. Use of truck on public roads shall conform to local regulations. Cross railroad tracks at an angle wherever possible. Do not park closer than eight feet from center of tracks.

40. Use minimum forward or reverse tilt when stacking and unstacking loads.

Never tilt forward unless load is over stack or at low lift height.



# Safety



17430  
16782

41. When extra length of material being handled makes it necessary to travel with your load elevated, do so with extreme care and be alert to load end swing when turning.



43. Report any faulty truck performance to your supervisor immediately. Don't try to make repairs yourself and do not operate the truck until the fault has been corrected.

42. It is risky to drive down a ramp or grade with your load first. Your truck can tip forward if the grade is steep enough. Always drive up or down grades with the load upgrade and never turn side ways on an incline.



17431  
13160

44. Follow a scheduled planned maintenance and lubrication program. All adjustments and repairs must be performed by thoroughly trained and authorized personnel only.

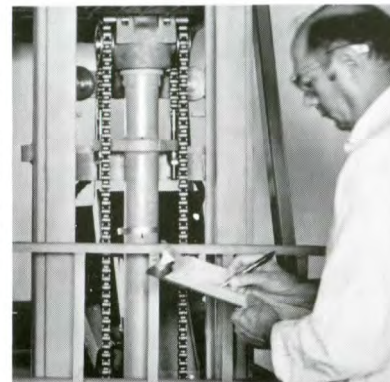

# Safety



17432

45. Check gauges, horn, upright and controls before you start. Inspect fuel, oil and water levels. Take pride in operating a good, clean truck.

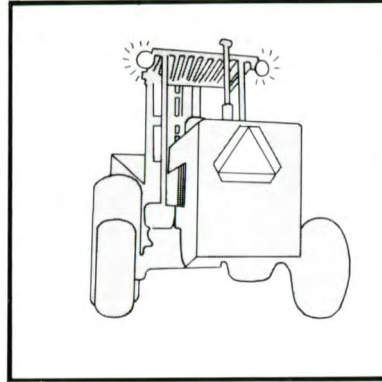

17425

46. Make certain that your slow moving vehicle warning sign is visible and that all lights are undamaged and operating.



17426

47. Park lift trucks in designated areas only. Lower forks to floor, tilt upright forward, place gear shift lever in any gear, put range shift lever in "park", remove switch key and block the drive tires.

# Safety



16838  
16840

48. If you must leave your lift truck unattended, make certain that traffic lanes are unobstructed and leave the truck as described in item 48.

49. Use high speed (8th) gear only to save time in transport over paved highways or smooth roads. Be careful and remember to lock brake pedals together for this type operation.

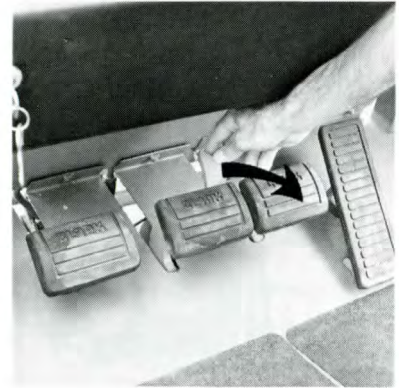

16839  
16835

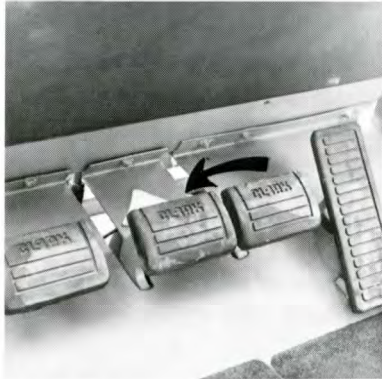

50. Make sure that the brake pedals are not locked together before placing the truck in normal operation. The brakes may be used independently to assist in turns during normal operation.

51. Remember – your safety and the safety of others depends upon you.

Keep your mind on operating your lift truck at all times.



# Operator's Compartment & Controls

1. Forward — Reverse control lever.
  2. Steering handwheel.
  3. Horn Button.
  4. Upright lift-lower control lever.
  5. Upright tilt control lever.
  6. Aux. valve control lever (optional).
  7. Accelerator pedal.
  8. Operators seat.
  9. Right wheel brake pedal.
  10. Brake pedal locking tab.
  11. Left wheel brake pedal.
  12. Transmission filler cap.
  13. Differential locking pedal.
  14. Transmission shift lever.
  15. Clutch pedal.
  16. Key switch
  17. Light switch.
  18. Engine hour meter.
  19. Fuel gauge.
  20. Water temperature indicator light.
  21. Engine oil pressure indicator light.
  22. Generator indicator light.
- \* — Hi-Low Range shift lever (located at right side of the operators seat).
- \* — Cold start adaptor (located on left side of the seat support).

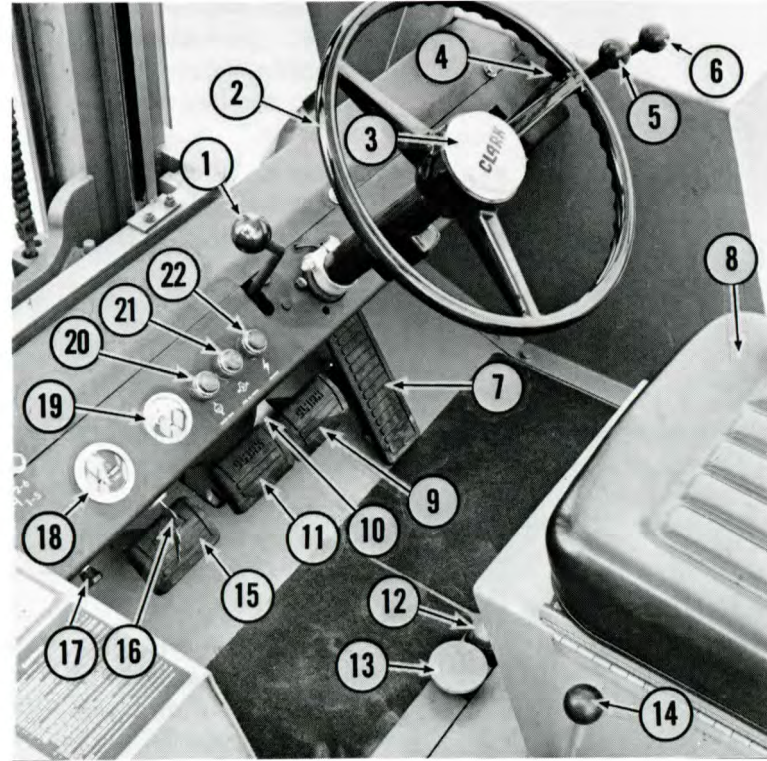

17423

# Before Operation

1. Each shift operator must complete an operator's daily check list at the beginning of his shift.

These daily check lists are available from your Clark dealer.

2. Walk around truck and visually check for damage and leaks.

Note all damage and leaks on check list.

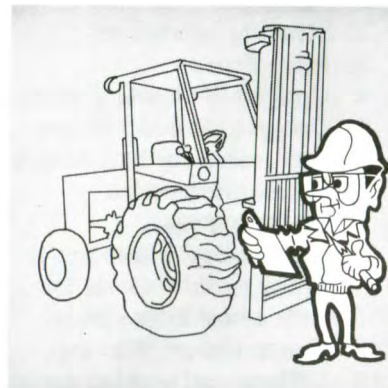

17427  
17453

3. Check condition of drive wheels and tires. Note any apparent drive wheel or tire damage on the check list.

Check drive tire pressure and adjust, if necessary, to pressures listed on page 37.

4. Check condition of steer wheels and tires. Note any apparent steer wheel or tire damage on the check list.

Check steer tire pressure and adjust, if necessary, to pressures listed on page 37.

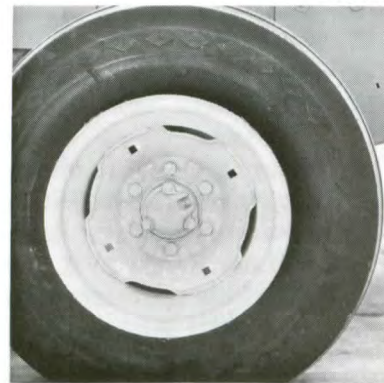

15197  
17420



# Before Operation

5. Check condition of overhead guard and load backrest extension.

Make certain that they are undamaged, properly positioned and mounted securely.



17417  
17418

6. Make certain the transmission is in 2nd or 3rd gear. Remove the seat hold-down nut and bolt and swing the seat up and away from you. Check condition of batteries, cables and terminals.



17419  
17459

7. Remove fluid level plugs from all battery cells and check fluid level in each. Add distilled water to cells as required and replace plugs.

Return operators seat to normal position and replace latch bolt.

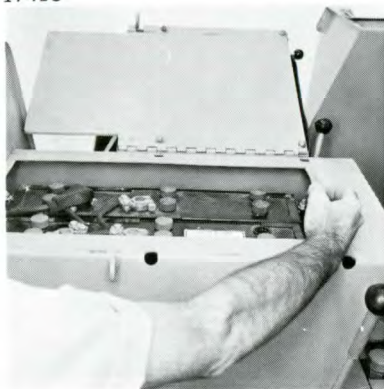

8. Visually check general condition of engine compartment. Check condition of fan, belts, wiring, hoses and fittings. Then mark your findings on the check list.

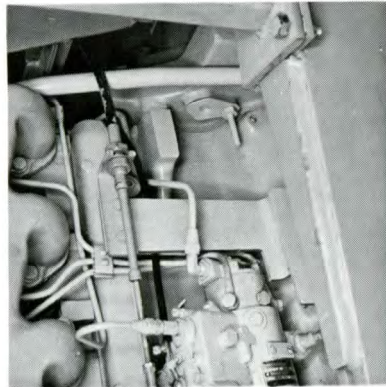

# Before Operation

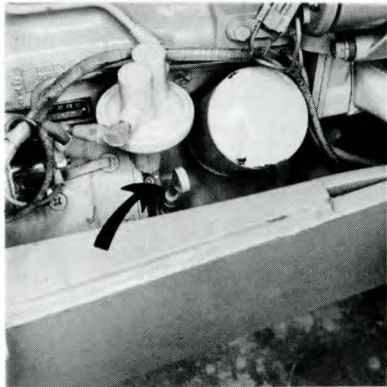

16841  
17416

9. Pull the engine oil dipstick from its support tube. Wipe it with a clean, lint free cloth and reinsert the dipstick fully into its support tube.

10. Pull dipstick from support tube and check engine oil level. Engine oil level must be maintained between the "add" and "full" marks on the dipstick. Remember that one quart of oil will raise the level from "add" to "full". DO NOT OVERFILL.

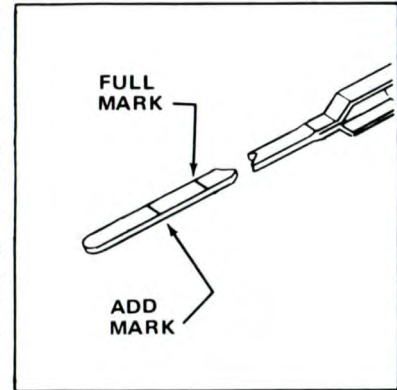

13239  
17415

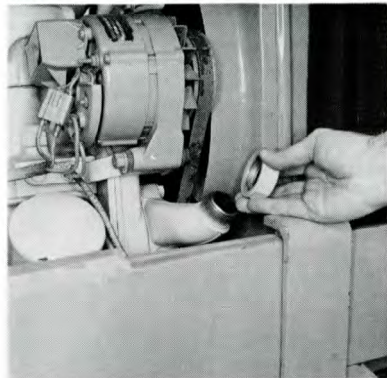

11. If you find it necessary to add oil refer to pages 38 and 39 for oil viscosity recommendations. Remove oil filler cap, add oil as required and replace cap.

12. Always recheck the engine oil level after adding oil. Remember to replace the dipstick after checking the oil level.

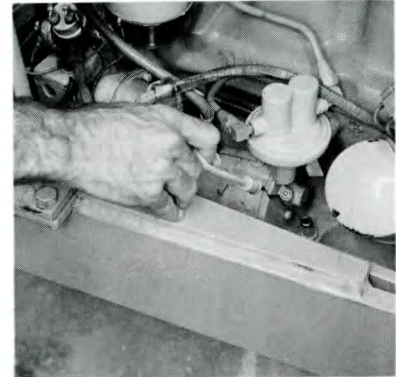



# Before Operation

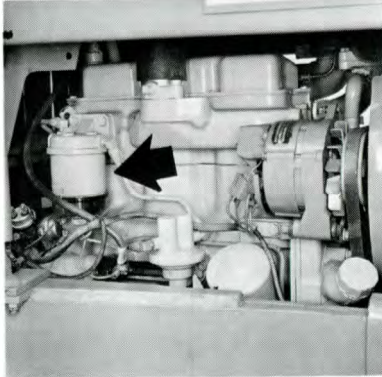

17412  
17414

13. Clean the outside of the fuel filter sediment bowl and visually check fuel for water or other contamination.

14. If fuel in the sediment bowl appears to be contaminated loosen the small plug at bottom of the bowl and allow foreign material to drain from the bowl.

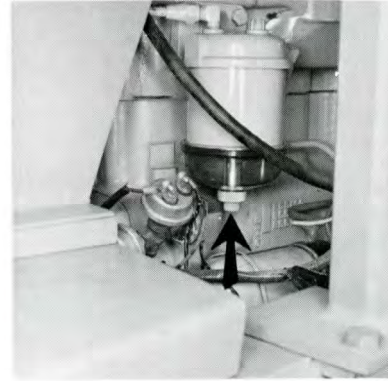

17413  
17411

15. At the lower right side of the fuel transfer pump is the primer lever.

Operate this lever several times until all deposits are drained from the fuel bowl.

16. Make certain primer lever is left at the lowest point of its stroke and tighten the fuel bowl drain plug finger tight.

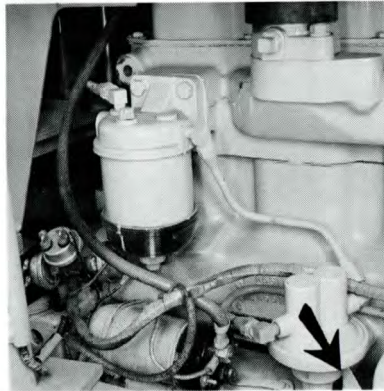
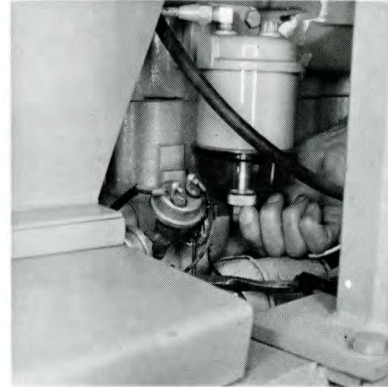

# Before Operation

17. Always check radiator coolant level with engine turned off and cold, if possible. Correct coolant level is midway between the top of the radiator core and the bottom of the filler neck.

**Caution** — Use extreme care when removing radiator pressure cap. The sudden release of pressure can cause a steam flash resulting in serious injury. Place a rag over the radiator cap and loosen slowly to allow gradual escape of steam.

**Never** add cold water or cold anti-freeze into the radiator of an overheated engine. Allow the engine to cool and avoid the danger of cracking the cylinder head or block. Keep engine running while adding water or anti-freeze. A solution of 50% ethylene glycol and 50% water is recommended — never use water only.

Remember to replace radiator cap and make certain that it is properly secured after check of radiator coolant level has been completed.

18. Check the drive wheels to see if they are blocked. If so, remove the blocks, carefully climb into the operators compartment and seat yourself in the operators seat.

19. Seat adjustment is accomplished by releasing short lever at lower right front of seat.

Position seat to provide easy access to all hand and foot controls, free lever and make certain that seat locks into desired position.

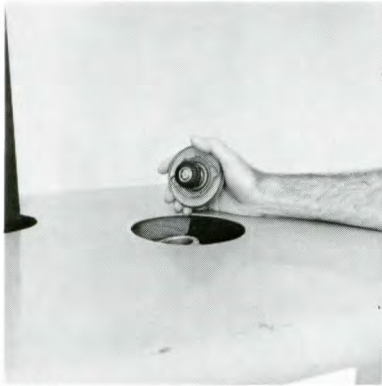

17408  
17409



17410

# Before Operation

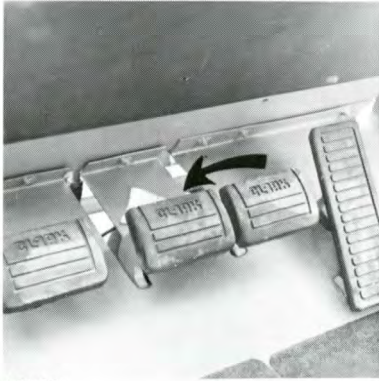

16840  
17458

20. Look at the brake pedals to make certain that they have not been left locked together. If they have — unlock them before going on to step 21.



22. Then press down firmly on left brake pedal. The pedal should be "firm". If the pedal feels "spongy" or "fades" under foot pressure DO NOT OPERATE THE TRUCK. Report the problem immediately.

21. Press down firmly on right hand brake pedal. The pedal should be "firm". If the pedal feels "spongy" or "fades" under foot pressure DO NOT OPERATE THE TRUCK. Report the problem immediately.



17406  
17407

23. The "High-Low" or "range" shift lever must be in the "park" position to start the truck. If your truck starts with this lever in any other position — report it so that proper adjustments can be made.



# Before Operation

24. Insert key into switch and turn key clockwise to first position. This will activate the hour meter, the fuel gauge and the ammeter indicator light.

25. Check the dash mounted fuel gauge.

Never try to start a diesel engine on an empty tank as serious pump damage may be the result.

Start your shift with a full tank.

26. Check the dash mounted engine hour meter. Make certain that it is operating and record the total hours on your daily check list.

27. The alternator indicator light should be on. If this light does not go out, and stay out, 10 seconds after the engine starts, the engine should be stopped until the cause is located and corrected.



16838  
13225

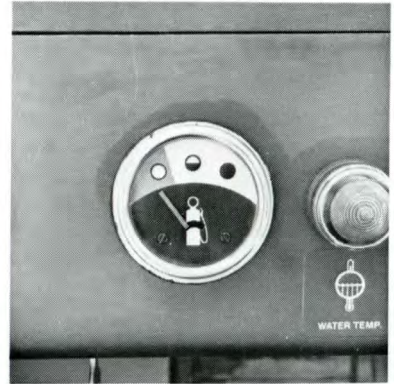

16842  
16843

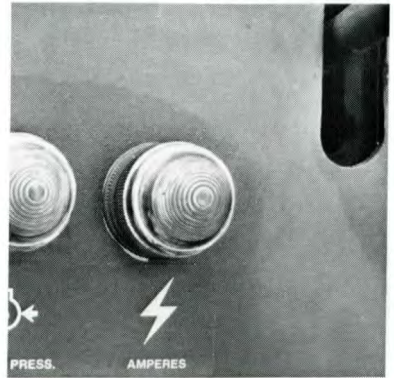

# Before Operation



16844  
16838

28. Place your left foot on the clutch pedal and push down to disengage the clutch. This will reduce the engine load while it is being started.

29. Place your right foot on the accelerator pedal and apply slight pressure to partially open the throttle.



17405



30. Now turn the switch key clockwise to engage the starter. Release the key as soon as the engine starts and it will automatically return to the normal "run" position.

Do not hold starter in the "engaged" position for more than 20 seconds at a time. If the engine fails to start during the first 20 seconds, release the key and wait at least two minutes before attempting restart. This will allow starter to cool.

If engine starts — then stops — wait a few seconds for starter and engine spin-down before restarting. Carefully release clutch pedal after engine has been started.

See pages 41-42 for cold start.

## Before Operation

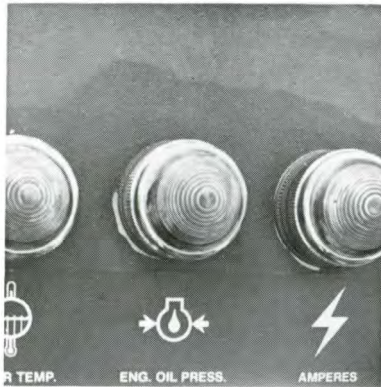

16845

31. Check the dash mounted low engine oil pressure indicator light. If this light stays on more than 10 seconds after the engine starts, or if this light comes on at any time during operation, STOP the engine until the cause of pressure loss is located and corrected.

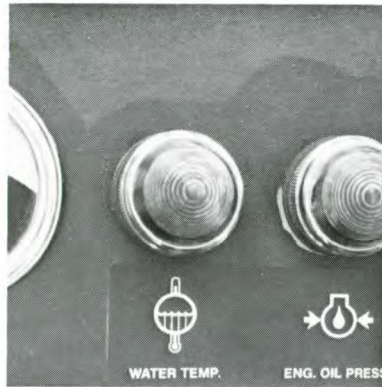

16846

32. Check the dash mounted engine water temperature indicator light. If this light comes on at any time during operation STOP the engine until the cause of the overheating is located and corrected.

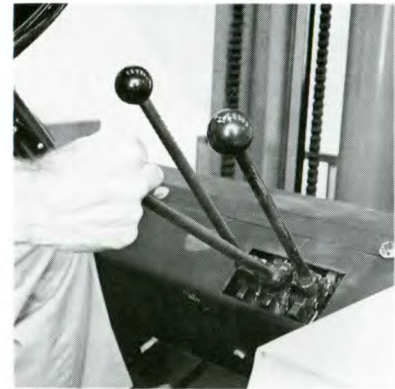

17404

33. Make certain that your forks are unobstructed, then gently pull back on the tilt control lever and hold until the upright reaches full back tilt. DO NOT HOLD THE LEVER BACK AFTER UPRIGHT REACHES FULL BACK TILT.....

# Before Operation

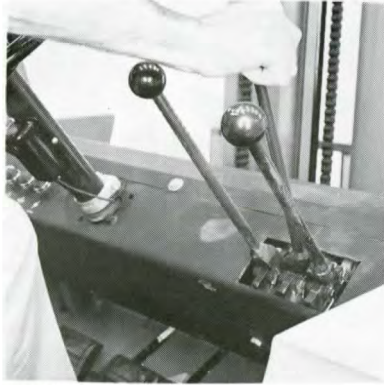

17403

34. Push tilt lever forward and hold until the upright tilts forward to near vertical position.

Return tilt control lever to neutral position to stop forward tilting action at desired point.

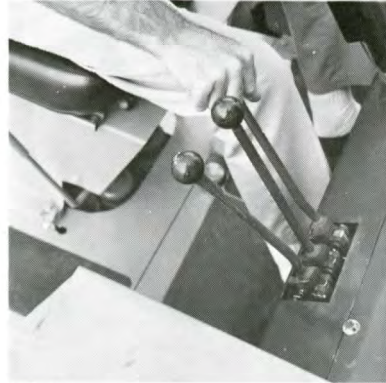

16836

35. Carefully check for adequate unobstructed overhead clearance, then pull back gently on the lift control lever and hold until the upright reaches maximum lift height.

Return lift lever to its neutral position to halt lift at the desired level.

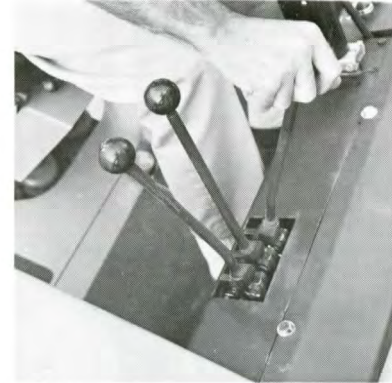

16837

36. Gently push the lift control lever forward and closely observe descent of the upright and carriage. Return the lift control lever to its neutral position to stop upright descent near (about 4-6 inches) floor level.

Record any erratic or unusual operation on your check list. Page 27

## Before Operation

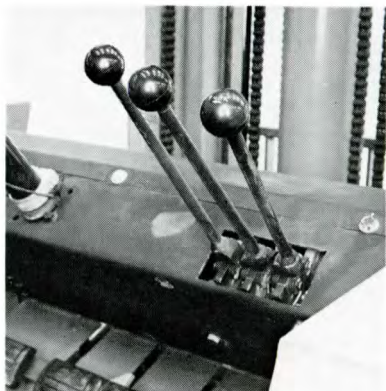

17402

37. Trucks equipped with hydraulic attachments or accessories will have one or more additional control levers mounted to the right of the lift and tilt control levers.

The function(s) of these levers should be checked with your supervisor before attempting operation.



13141

38. Press horn button to determine if horn is operational.

If horn does not function properly record it on your check list and report it to the designated authority when you have completed your "before operation" checks.



16847

39. Rotate steering handwheel to the left and to the right.

Any excessive or unusual free travel, looseness or binding must be noted on your check list.



# Before Operation



16834  
16848

40. Check all around truck to make certain that your desired path of travel is unobstructed.

41. Place your right foot on both brake pedals and press down firmly to apply the truck service brakes.



17457  
16844



42. The forward-reverse control lever can be shifted without declutching. Pull it toward you for reverse (or push it away from you for forward).

43. Place your left foot on the clutch pedal and apply downward pressure to disengage the clutch.



## Before Operation



17401  
16850

44. Move the High-Low range shift lever out of the park (P) position and into the Low (L) range position. Refer to shift pattern at right side of dash.

45. Move the transmission gear shift lever into the proper position for 1st gear. Refer to shift pattern at left side of dash.



16849  
17457

46. Release truck service brakes, apply slight right foot pressure to the accelerator pedal, gradually release the clutch pedal and press the accelerator until the truck begins to move smoothly in reverse.

47. Release the accelerator pedal, place right foot on both brake pedals and apply gentle downward pressure to smoothly slow the truck to a near stop.



# Before Operation



17400  
17457

48. Push the forward-reverse control lever away from you into position for forward travel. (The clutch does not have to be disengaged when changing position of the directional control lever.)



50. Release the accelerator pedal, place your right foot on both brake pedals and apply gradual downward pressure to bring your truck to a smooth stop while . . . .

Code: OI-375 Sep. 75

49. Release the truck service brake pedals, place your right foot on the accelerator pedal and apply steadily increasing downward pressure until the truck begins to move forward.



17405  
16844

51. . . . placing your left foot on the clutch pedal and applying downward foot pressure to disengage the clutch.



# Before Operation

52. Make certain that the transmission gear shift lever is in one of the gears (not neutral). You cannot get High-Low range lever into park unless transmission is in gear.

53. Move High-Low range shift lever from low (L) range position to park (P) position.



16851  
16850



17401  
16837

54. Release clutch pedal.

55. Lower the lift forks to the floor.

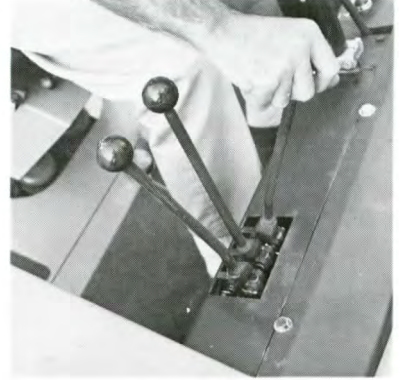

# Before Operation



17403  
16838

56. Push forward on tilt control lever to lower fork tips to floor.



58. Turn key counter-clockwise to the "off" position. This will close a solenoid on the injection pump and stop the engine.

57. Accelerate the engine slightly (about 1500 RPM) and allow to run for a short time (30 to 60 seconds).



17405  
17409

59. When the engine has come to a complete stop, remove the key from the switch and carefully get off the truck.



## Before Operation

60. Place 4 x 4 blocks ahead of, and behind both truck drive wheels to prevent accidental roll.



17454  
17397

62. Unscrew the cap on this dipstick support tube, pull the dipstick and wipe it dry with a clean, lint free rag.



61. Behind the left hand drive wheel on the left hand side of the transmission case you will find a short dipstick support tube.

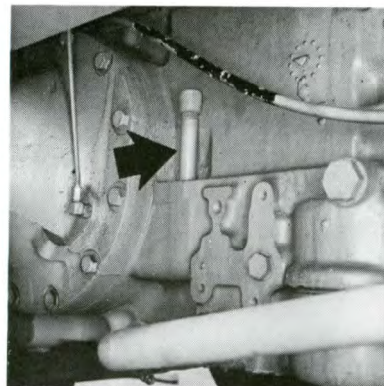

17399  
17456

63. Replace the dipstick in its support tube but do not screw the cap onto the threads — let the cap rest on top of the threads.

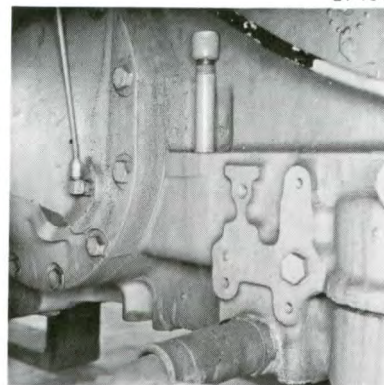

# Before Operation



17398  
17455

64. Pull the dipstick from the support tube and check the oil level. If oil level is down to the bottom mark on the dipstick . . . .

65. Add oil by removing filler cap in floor board. Make certain that the cap is securely replaced.



16852  
15197



66. Add only enough oil to bring level to top mark on dipstick. Do not overfill. Recheck after adding oil and replace the dipstick.

67. Review your check list to make certain that it is complete. Sign it and turn it in to the designated authority.



# Operating Hints

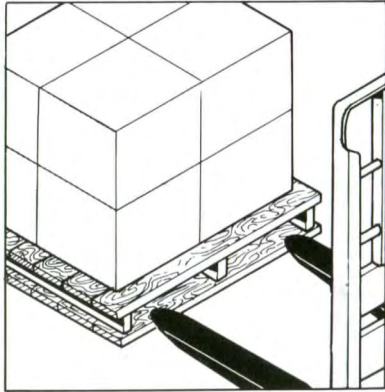

13203  
10759

1. Remember to approach load slowly and squarely to avoid damaging the material being handled and to minimize truck maneuvering.

Load should be centered and forks should be near the outside edges to improve stability — if they are not . . . .

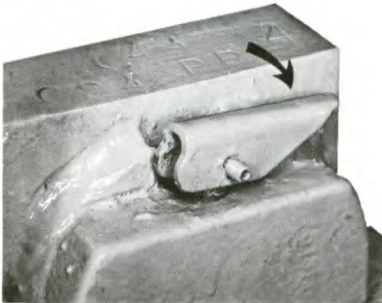

2. Adjust them by lifting fork lock lever and sliding forks to the desired position then . . . .

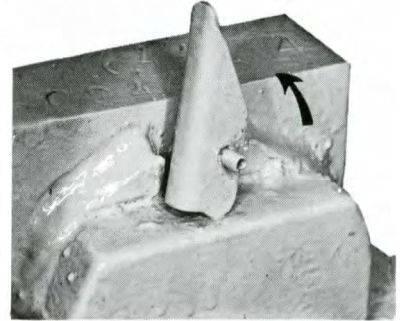

10758  
16835

3. . . . remember to lower lever to lock forks securely into notch atop fork bar.

4. Always be alert for abrupt changes in the operating characteristics of your truck.

Unusual noises or sudden changes should be reported to your supervisor immediately.





# Operating Hints

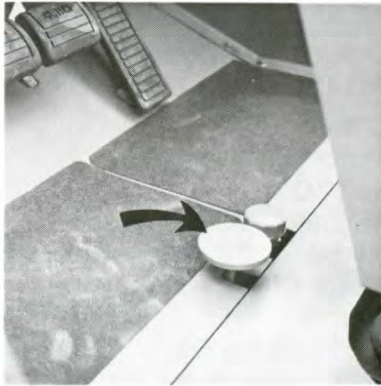

16853

5. When slippery conditions are anticipated or encountered step down on the differential lock to direct power equally to both front wheels.

Unequal traction will keep the lock engaged, it will release automatically.

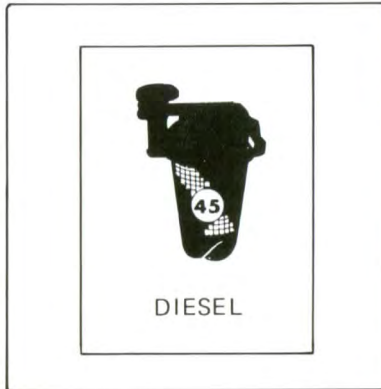

6. Recommended fuel is automotive quality diesel fuel as defined by ASTM D975, grades 1D and 2D, with a sulfur content of less than 0.5% (weight) and a Cetane rating of 45 or more.

## TIRE PRESSURES

Tire Size	Type	Ply Rating	Inflate To
11L-15	Steer	6	32 PSI
19.5L-24	Drive	8	24 PSI
19.5L-24	Drive	12	34 PSI

### Major Brand Fuel Suppliers

Shell Premium Dieseline OR45  
Sun Diesel fuel 245T  
ARCO Premium Diesel  
ARCO Diesel No. 1 and No. 2  
Gulf Diesel No. 1 and No. 2  
Amoco Diesel fuel No. 10  
American Premier Diesel fuel No. 2D  
Citgo Diesel fuel No. 1 or No. 2  
Texaco Diesel chief No. 1  
Mobile Diesel fuel  
Mobile Diesel fuel special

# Operating Hints

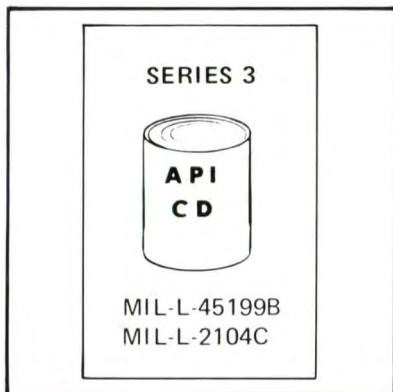

SPECIFICATION To meet API Service Classification "CD" per SAE Report J183 and equivalent Series 3 and/or MIL-L-45199B specifications. Also MIL-L-2104C when applicable. Sulfated ash content 1.65% maximum.

## SINGLE VISCOSITY ENGINE OIL

### TYPICAL PRODUCT RECOMMENDED BY MAJOR BRAND OIL SUPPLIERS

Chevron DELO Super 3 Oil  
Shell Rimula Motor Oil  
Sunfleet S-3 Motor Oil  
ARCO Fleet MS-3 Motor Oil  
Gulf Super Duty Motor Oil  
AMOCO 300 Motor Oil  
Citgo C500 Motor Oil  
Texaco URSA LA-3 Motor Oil  
Mobil Delvac 1300 Series Motor Oil  
... or the equivalent to the above.

## • ENGINE CRANKCASE OIL

### RECOMMENDED SINGLE SAE VISCOSITY

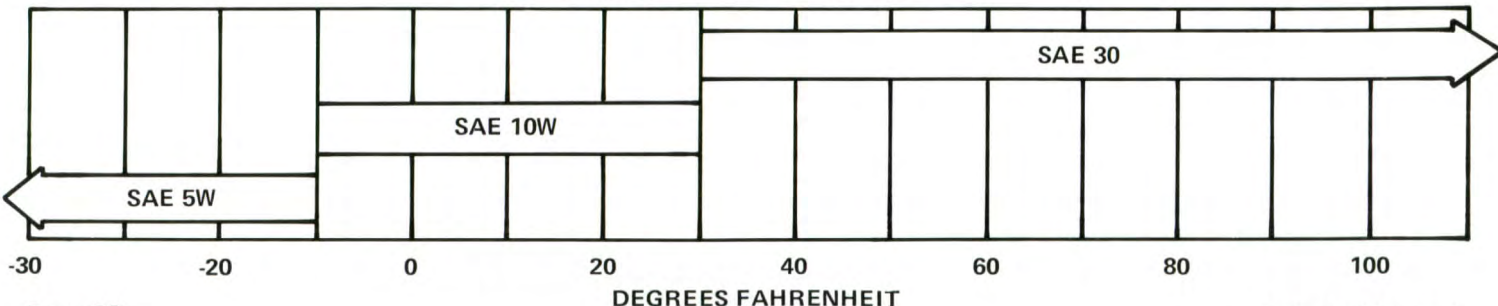

# Operating Hints

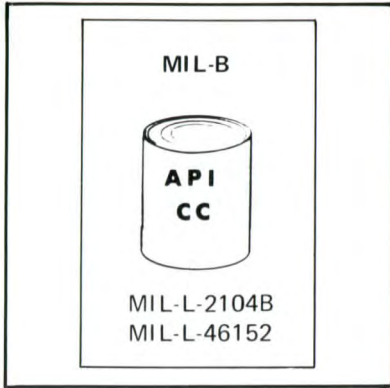

## MULTI VISCOSITY ENGINE OIL

SPECIFICATION To meet API Service Classification "CC" and "SC" per SAE Report J183 and/or MIL-L-2104B. Sulfated ash content 1.00% weight maximum. Zinc content 0.06 to 0.10% weight maximum.

This specification includes oils meeting Specification MIL-L-46152 when applicable. Also, API Service "SC"/"SD" (Formerly "MS") oils may be preferred under stop-and-go or light service conditions.

## TYPICAL PRODUCT RECOMMENDED BY MAJOR BRAND OIL SUPPLIERS

Chevron RPM DELO Multi-Service Oil  
Shell X-100 or Rotella, Rotella T  
Sunfleet H.P. or Citgo C300 Motor Oil  
ARCO Fleet X.H.D. Motor Oil or ARCO Fleet H  
Gulflube Motor Oil X.H.D.  
AMOCO 200 Motor Oil  
Texaco Havoline or URSA Extra Duty Motor Oil  
Mobil Delvac 1100B or 1200 Series Motor Oil  
... or the equivalent to the above.

## ● ENGINE CRANKCASE OIL

### RECOMMENDED MULTI SAE VISCOSITY

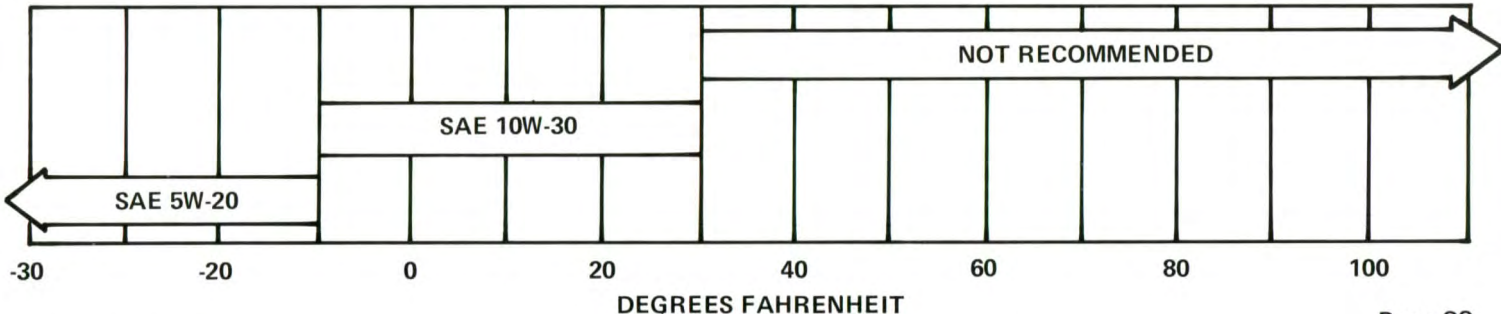

# Operating Hints



17428

regulating engine speed to maintain maximum smoothness.

- All models must be brought to a complete stop before shifting the High-Low range control lever from one position to another.
- Always use low range when negotiating grades or ramps and when operating over rough or unimproved surfaces.
- Transmission gear ratios, within a range, may be changed upward or downward by "double clutching". When "up-shifting" or "down-shifting" the transmissions on these trucks, you must first, depress the clutch pedal fully and move transmission shift lever to neutral. Release the clutch pedal, (accelerate the engine if down shifting), depress the clutch pedal, place transmission shift lever in next higher (if up-shifting) or next lower (if down-shifting) gear and release the clutch pedal while regulating engine speed to maintain maximum smoothness.
- Selecting the correct drive gear ratio is a very important operators function. Choosing the proper gear ratio for the job being done will result in better truck performance with longer drive train component service life.
- When operating surface is rough, or soft, or if grades or ramps are to be negotiated, you should use the lowest transmission gear ratios available to you because — here power is needed — not speed.
- As a general rule of thumb — DO NOT LUG THE ENGINE. Overworking the engine thru use of a "too high" gear ratio will create excessive heat and shorten component service life — IF YOU ARE IN DOUBT — USE NEXT LOWER GEAR.

# Cold Weather Starts

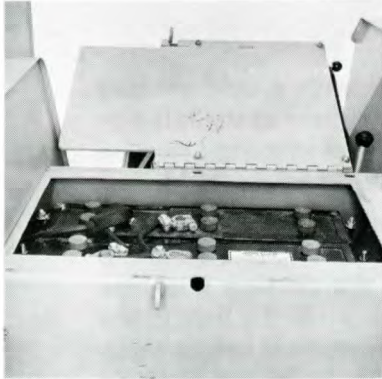

16856

16854

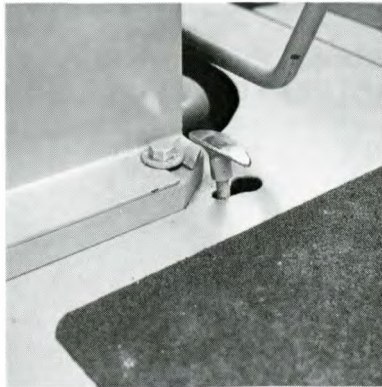

1. Cold weather starts can be made easier by using a 12 volt "booster" battery connected in parallel with the 12 volt batteries on the truck. Use jumper cables to connect the booster battery positive (+) terminal to the truck battery positive (+) terminal and the booster battery negative (-) terminal to the truck battery negative (-) terminal. **THE TRUCK BATTERIES ARE NEGATIVE GROUNDED – REVERSING POLARITY WILL DAMAGE THE ELECTRICAL SYSTEM.**

2. Engine cranking speed may be increased, during cold weather starts, by disengaging the clutch from the engine. To do this lift the T shaped release handle up until it locks in the disengaged position.

**OPERATION OF THE ENGINE WHILE THE CLUTCH IS DISENGAGED WILL RESULT IN DAMAGE TO THE REVERSER. BE SURE TO ENGAGE THE CLUTCH DISCONNECT LEVER IMMEDIATELY AFTER THE ENGINE STARTS.**

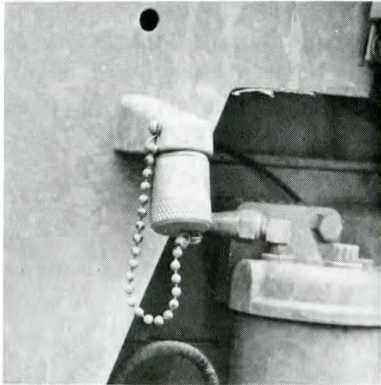

16855

3. Some lift trucks will be optionally equipped with a cold starting fluid adaptor. This attachment, if used, will be mounted at the left side rear of the operators seat support and is used to inject atomized starting fluid into the engine air intake system at temperatures below 32<sup>o</sup> F.

To use this cold starting aid, remove the safety cap and the plastic spray button from the top of an aerosol can of starting fluid. Unscrew the cap from the fluid adaptor on the truck. Position the starting fluid can under the adaptor with the tube at the top of the can in the hole in the adaptor. Now turn the engine over one or two revolutions before injecting starter fluid. Keep the engine turning, pull up on the can to inject fluid then release pressure on the can. Relax pressure on the can between "shots" of fluid and stop injecting "shots" of fluid as soon as the engine starts.

When engine starts, replace the safety cap on the can and replace the cap on the adaptor. Store starting fluid cans at room temperature and NEVER PUNCTURE OR INCINERATE STARTING FLUID CONTAINERS.

# Parking



17426  
16838

1. Park lift trucks in designated parking areas only.

Do not block aisles, exits, entrances or access to fire or emergency equipment.

2. Make sure that transmission is in gear, High-Low range shift lever is in "park" and upright forks are lowered to floor.

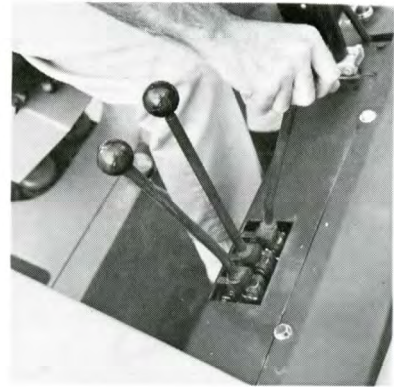

3. Engine must then be stopped and key removed from switch.



4. Then you should carefully dismount from truck, firmly block the drive wheels to prevent accidental roll and turn the key into the designated authority.



## Other Things to Remember



17424

- NEVER attempt to start a forklift truck by towing or pushing it. This is dangerous and could result in damage to the reverse clutches.
  - The reverser gear ratio is such that forward speeds are 35 percent faster than reverse speeds. Use extreme care when reversing direction and NEVER attempt to reverse directions at higher speeds.
  - NEVER attempt to turn the truck in any direction with the differential lock engaged as this may result in severe drive train damage.
  - NEVER depress the clutch pedal when using the brakes to slow the truck. When you do this you lose the braking effect of the engine which helps slow the truck.
  - NEVER depress the clutch pedal when going downhill and NEVER allow truck to coast. Coasting may result in damage to reversor packs.
- Always remember to allow sufficient engine warm-up time before operating your truck under full load conditions or in high gear.
  - Avoid unnecessary engine idling as this causes coolant temperature to fall below normal operating level which will dilute crankcase oil.
  - Do not let engine idle for extended periods of time with forward - reverse lever in the forward position. To do so will damage the forward selector pack extensively.







# For Handy Reference

RECORD THE FOLLOWING INFORMATION PERTAINING TO YOUR TRUCK

Model ..... \_\_\_\_\_

Serial No. .... \_\_\_\_\_

Attachments ..... \_\_\_\_\_

Truck Weight (Empty) ..... \_\_\_\_\_

Truck Rated Capacity ..... \_\_\_\_\_

Gross Truck Weight (With Rated Load) ..... \_\_\_\_\_

Transmission Type ..... \_\_\_\_\_

Fuel Type (Gas, L.P. Gas or Diesel) ..... \_\_\_\_\_

Tires (Pneumatic, Cushion) ..... \_\_\_\_\_

Type Controls (Console or Column Mounted) ..... \_\_\_\_\_

Customer Truck Identification ..... \_\_\_\_\_



Additional copies of this manual may be purchased from  
YOUR AUTHORIZED CLARK DEALER

---

**CLARK<sup>®</sup>** Material Handling  
Company

Lexington, KY 40511  
Printed in USA