

CLARK

**Industrial
Truck
Division**



OPERATOR INSTRUCTIONS

CLARKLIFT IT — 40B

ROUGH TERRAIN LIFT TRUCK

4000 LB. RATED CAPACITY

BOOK NO. OI-366 1st REV

TABLE OF CONTENTS

	Page
Foreword	1
Major Component Identification	2
Safe Operating Rules and Practices	3-14
Operator's Compartment and Controls	15
Operator's "Before Operation" Checks	16-29
Operating Hints	30-32
Fuel and Engine Oil Recommendations	32-33
Parking Procedures	34-35
Towing Procedures Caution Note	35
Handy Reference Data	37

FOREWORD

A large share of the total cost of most every product can be traced to handling. This includes in-plant transport, storage, freight, warehousing and final delivery. In many cases, the fork lift truck plays a key role in each of these operations.

You and your lift truck can significantly reduce these costs . . . or increase them. A lift truck costs thousands of dollars. Add to this the cost of operation (operator's pay, fuel, maintenance, fringe benefits, etc.) and it can easily be seen that this is an important investment for any company. The investment has now been made and it is up to you to ensure that maximum return is realized.

This manual will help the "Qualified Operator" become familiar with the lift truck's major components, its operating controls, special features and the function(s) of each.

This publication is not a training manual but rather, a guide to help the "Qualified Operator" to more safe and efficient operation of a Clark lift truck.

Operator training manuals are available through your Clark dealer.

Clark trucks are built to take hard work not abuse — they are built to be dependable, but — as with any other truck — they are only as good as the man behind the wheel and the men responsible for maintaining them.

This manual guides the operator through correct procedures for checking, starting, operating, stopping and parking the lift truck.

Read it, Study it, Keep it handy.

Know Your Truck

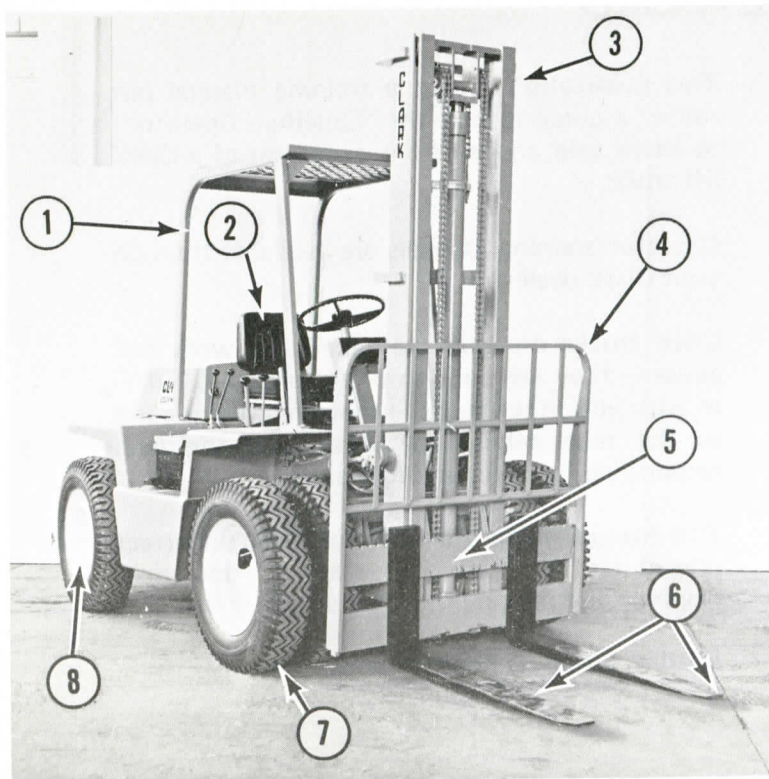

1. Overhead guard
2. Operator's compartment
3. Upright assembly
4. Load back rest extension
5. Lift carriage
6. Load forks
7. Drive wheel and tire
8. Steer wheel and tire

16760

CLARKLIFT IT — 40B
TOWABLE LIFT TRUCK
4000 LB. RATED CAPACITY

Safety



13696

16759



Code: OI-366 REV JAN 82

1. Only physically qualified and thoroughly trained personnel should be authorized to operate the Clark IT40 "B" Model Towable Lift Truck.

3. Learn how your truck is operated. Know its safety devices, how they function and how the special attachments, if any, work.

2. Prominently placed on every Clark truck is a list of basic rules for operation. These rules are for the protection of you and others in your operating area. Be familiar with them.

4. The wearing of "hard hat", safety glasses and safety shoes is recommended. Dress suitably and avoid loose fitting clothing.

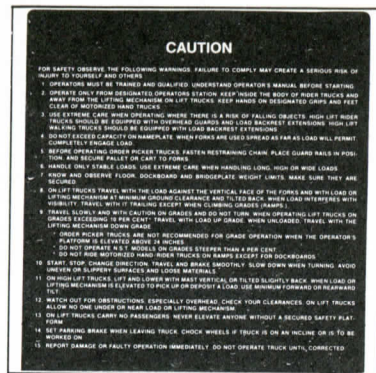

13110

16762



Safety

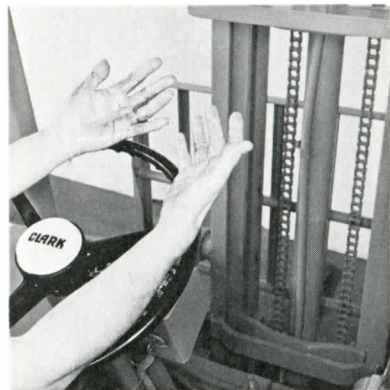

5. Never operate a lift truck with wet or greasy hands or shoes.

16742
16750



7. Always look all around the truck before moving it in any direction. Then remember to start and stop slowly and smoothly.

Page 4

6. Before operating any lift truck, test the horn, service brakes, hand brake, steering, lift-tilt controls, directional controls and any special devices for proper operation. Report any improper operation to the proper authority.

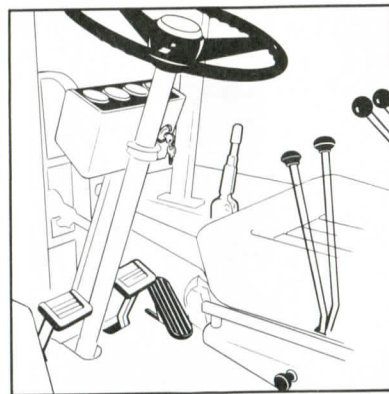

16763
16764

8. Operate the truck only in designated truck routes and keep operating aisles clear. One-way traffic is recommended. If this is not practical in your operation heed highway regulations and drive to right of aisle centerline.

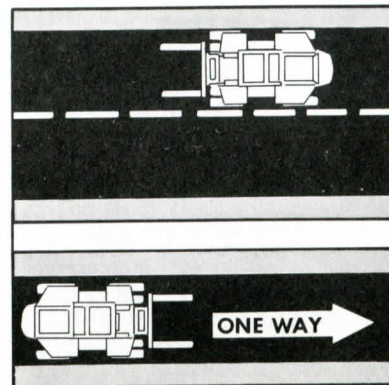

Code: OI-366 MAR 75

Safety



16745

13087



9. Be alert for pedestrians, other trucks or obstacles in your path of travel.

11. Obey all posted traffic rules and warning signs.

10. Sound horn at all corners, exits, entrances and when approaching pedestrians or bystanders.

12. Maintain a safe distance from the truck ahead of you at all times.

Assure ample distance to stop smoothly and safely should the need arise.



13141

16765

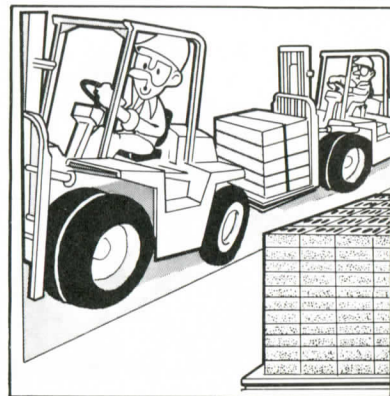

Safety

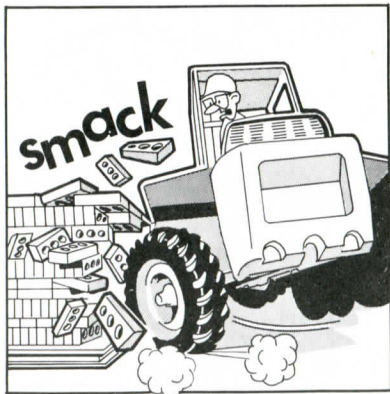

13. Be aware of rear end swing and be alert to prevent rear end swing damage to material in your operating area.

16766

16767

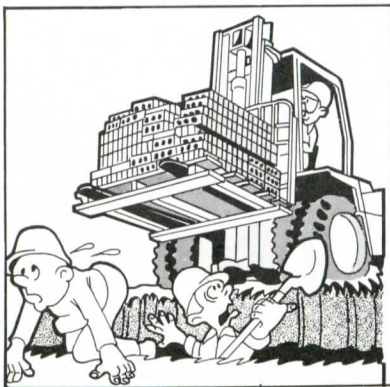

15. Be extremely cautious when operating truck near edge of loading dock, embankment, ditch or ramp.

14. Be aware of the position of your fork tips when the truck is in motion. Be alert to prevent striking anything with fork tips.

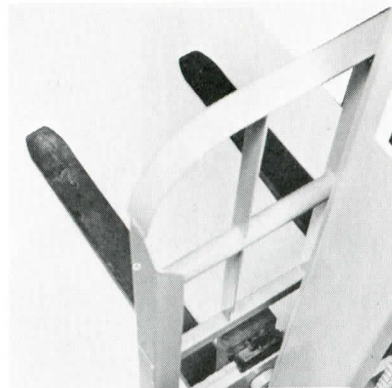

13145

16768

16. Make certain that vehicle being entered, loaded or unloaded has been blocked to prevent accidental roll.

Bridge plates, if used, must have adequate strength, width, guard rails, each side (minimum 3" high recommended) and be properly secured.

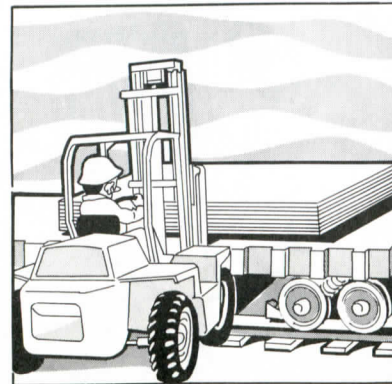

Safety



16769

17. Never allow stunt riding or indulge in horseplay while operating a fork lift truck.

18. Never use your truck to push or tow another. Never allow your truck to be pushed by another.

IT40"B" model trucks should never be towed unless they have been optionally equipped with Clark approved tow bar assembly.



13095

16771



19. Never carry unauthorized passengers. The quick response of a lift truck may cause riders to fall off. Besides, they distract you and this is dangerous.

20. Know the capacity of your truck and its attachment (if any) and never exceed it. Study your truck data capacity plate and learn the facts stamped in areas 1 through 8.

Pay particular attention to area 3 and refer to item 46 on page 14.

16770

CLARK EQUIPMENT				1			
INDUSTRIAL TRUCK DIVISION				BATTLE CREEK, MICHIGAN			
MODEL NO.		2		TYPE		3	
SERIAL NO.							
ATTACHMENTS							
4							
CAPACITY WITH ATTACH. LISTED ABOVE OR WITH FORKS - UPRIGHTS VERTICAL							
LBS		A		B		C	
5							
APPROX. WT. ALL TRUCKS				LESS BATT. - ELECTRICS			
APPROX. WT. ELECTRICS ONLY				WITH MAX. BATT. WT.			
BATTERY				7		8	
CAPACITY		LBS		VOLTS			
FOR OTHER CAPACITIES - CONSULT MANUFACTURER AS RELEASED FROM FACTORY THIS TRUCK MEETS THE DESIGN SPECIFICATIONS ESTABLISHED IN AMERICAN NATIONAL STANDARD FOR POWERED INDUSTRIAL TRUCKS.							
PART II, ANSI B 56.1-1969							

Safety

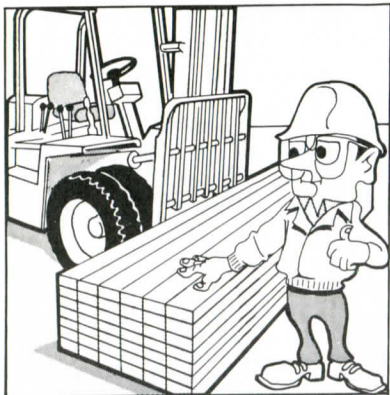

21. Thoroughly inspect all loads to be moved for overload and/or poor balance. If the stability of a load is questionable, don't move it.

16772

16751

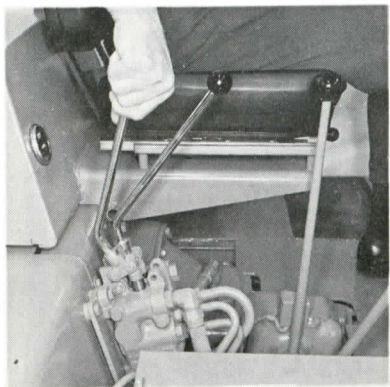

23. Before lifting check to insure adequate unobstructed overhead clearance. Gradually and smoothly pull back on lift control lever. Return lever to neutral to stop lift at desired level.

22. Unstable loads are a hazard to you and to your fellow workers. Always make certain that your load is well stacked and evenly positioned across both forks. Never attempt to lift a load with only one fork.

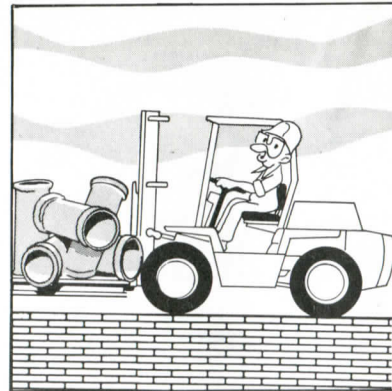

16773

16743

24. Push forward on control lever to lower load. Descent of load may be stopped at desired level by returning lever to neutral position.

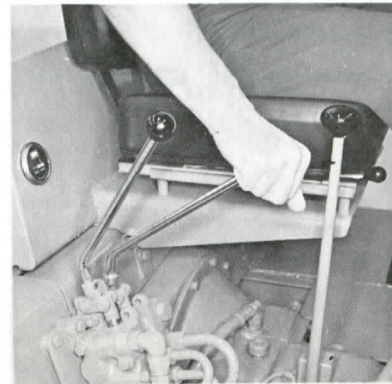

Safety

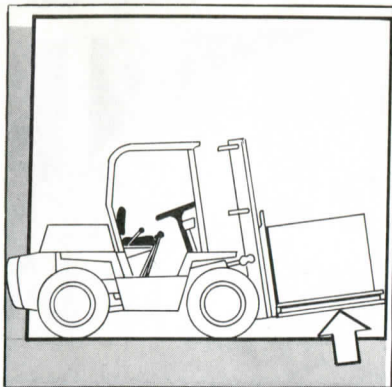

25. Always travel with load NEAR the operating surface and upright tilted back to cradle your load.

Never lift or lower the load while your truck is in motion and remember to keep your load upright when operating on ramps or inclines.

16774

16745



27. Remain seated at all times and keep head, hands, arms, feet and legs within the confines of the operator's compartment.

Never reach into the upright for any reason.

Never climb on the upright or use it as a ladder.

Code: OI-366 MAR 75

26. Never permit anyone to stand or walk under elevated forks or other load engaging attachments if machine is so equipped.

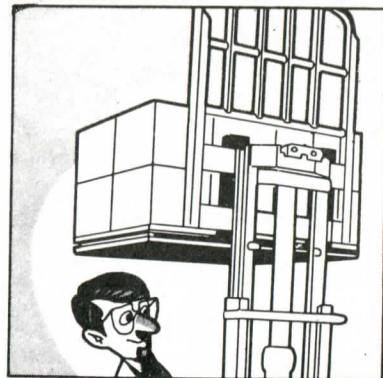

13522

13103

28. Slow down for turns, ramps, bumps, cross aisles, wet or slippery floors and at all times when visibility is restricted.

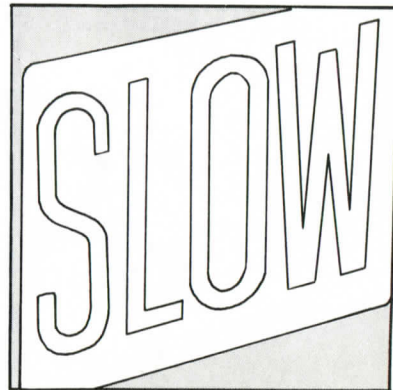

Safety

29. Know and observe floor load limits and overhead clearances in all operating areas. Make certain that floors of boxcars, trucks, trailers and elevators are adequate before entering.

30. Use caution when placing loads or traveling near water pipes, overhead sprinklers, electrical wiring, steam pipes, heaters or other fragile or dangerous equipment or material.

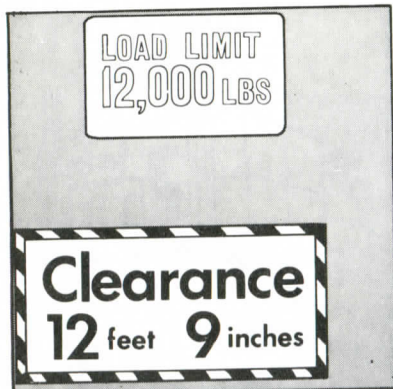

13102
14616

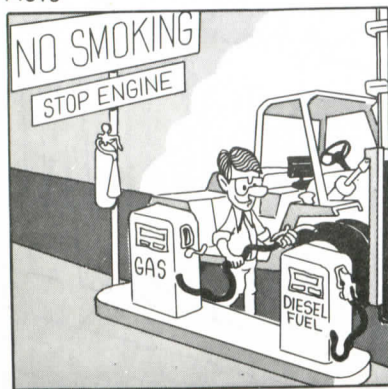

31. Lift trucks must be refueled in designated areas only. Engines must be stopped and no smoking regulations strictly enforced. Spilled fuel must be washed away or completely evaporated and the fuel tank cap properly replaced before restarting the engine.

32. Never smoke or allow anyone to smoke in areas where batteries are being charged or in areas where fuels or other flammable fluids or materials are used or stored. Batteries must be charged in designated areas only and must be serviced only by thoroughly trained and qualified personnel.

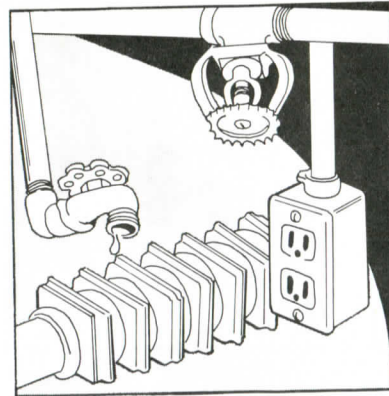

13104
13107

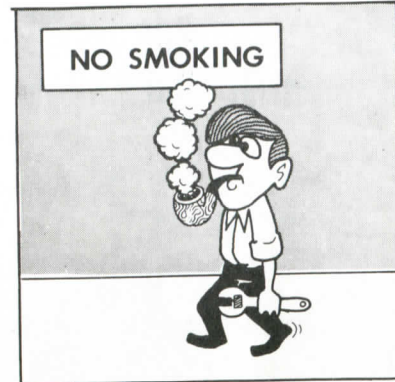

Code: OI-366 MAR 75

Safety

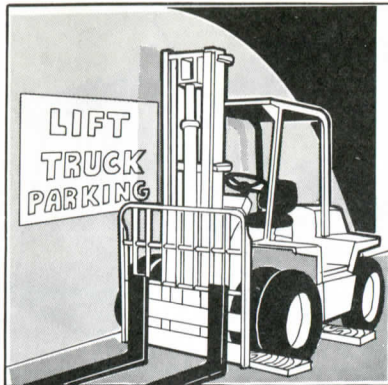

16775
16750



Code: OI-366 MAR 75

33. Park lift trucks in designated areas only. Lower forks to floor, tilt upright forward, place directional control in neutral, apply parking brake, remove switch key and block drive wheels to prevent accidental roll.

34. If truck is to be left unattended make certain that traffic aisles are unobstructed and leave truck as described in item 33.

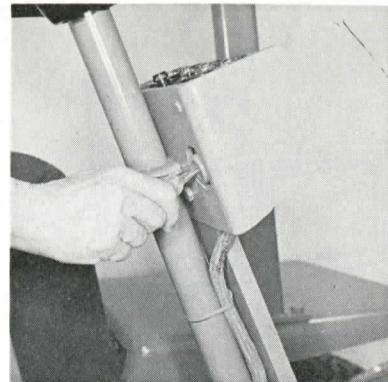

16729
16776

35. When handling bulky loads which, because of their size and shape, restrict your vision — operate your truck in reverse to improve visibility.

36. Overhead guards and load backrest extensions are for your protection. Make certain they are securely mounted and undamaged before operating your truck.

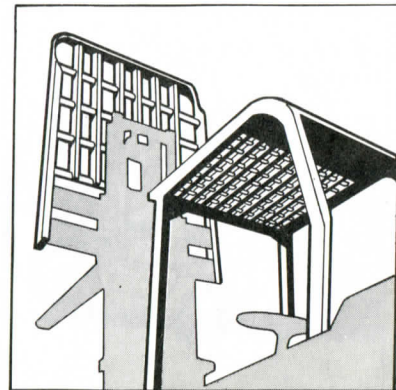

Safety



37. Lift trucks are not designed as personnel elevators. If your truck must be used this way always use a properly designed safety platform securely attached to the forks.

16777

16779

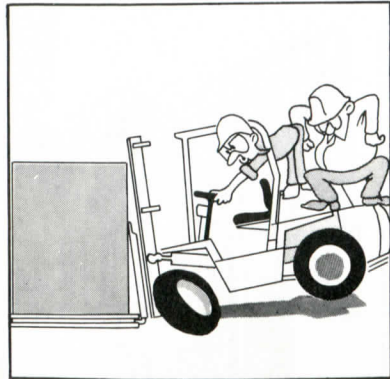

39. Overloading is extremely dangerous. You don't have complete control of your truck and you are causing unnecessary wear.

Never add to your counterweight, always break down the load.

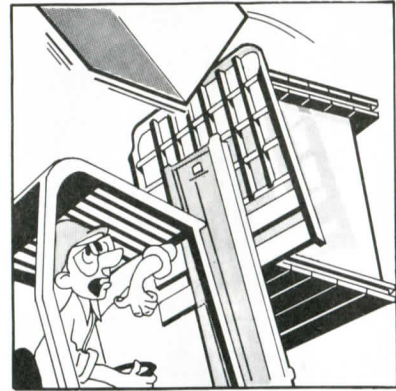

38. Don't handle double tiered loads. They're unstable and difficult to control. Even an overhead guard can't fully protect you from heavy objects dropped from these heights.

16778

16780

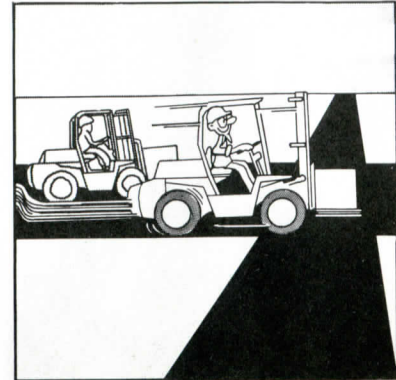

40. Don't pass other trucks traveling in the same direction at intersections, blind spots or other dangerous locations.

Safety



16781

41. Check gauges, horn, upright and controls before you start. Inspect fuel, oil and water levels. Take pride in operating a good, clean truck.

42. Report any faulty truck performance to your supervisor immediately. Don't try to make repairs yourself.



16782

16783

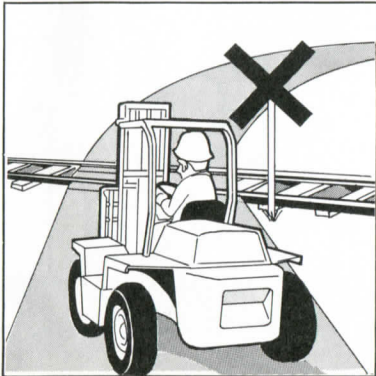

43. Use of truck on public roads shall conform to local regulations. Cross railroad tracks at an angle wherever possible. Do not park closer than eight feet from center of tracks.

44. Use minimum forward or reverse tilt when stacking and unstacking loads.

Never tilt forward unless load is over stack or at low lift height.



16784

Safety

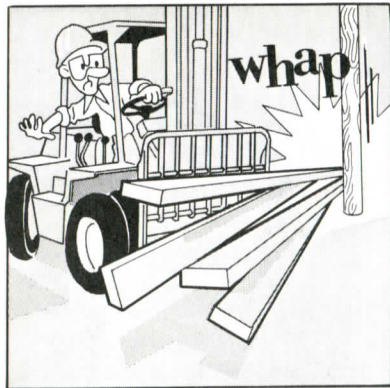

45. When extra length of material being handled makes it necessary to travel with your load elevated, do so with extreme care and be alert to load end swing when turning.

16785

13160

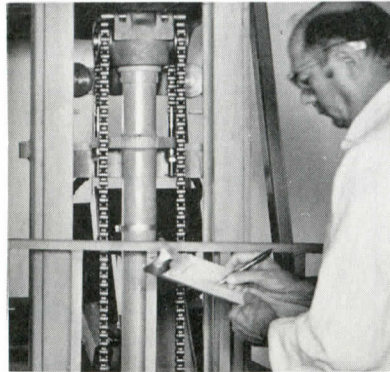

47. Follow a scheduled planned maintenance and lubrication program.

All adjustments and repairs must be performed by thoroughly trained and authorized personnel only.

46. Know the construction type of your truck and make certain that trucks of this type may be operated in restricted areas before entering. Never take an unauthorized truck into restricted or hazardous areas. (Refer to item 20 on page 7.)

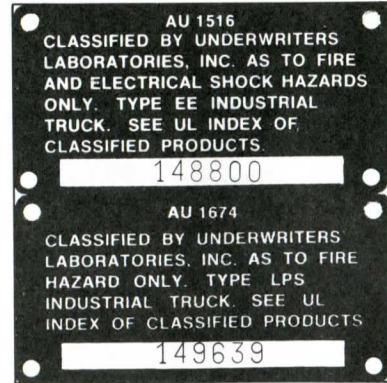

13178

16745



Operators Controls

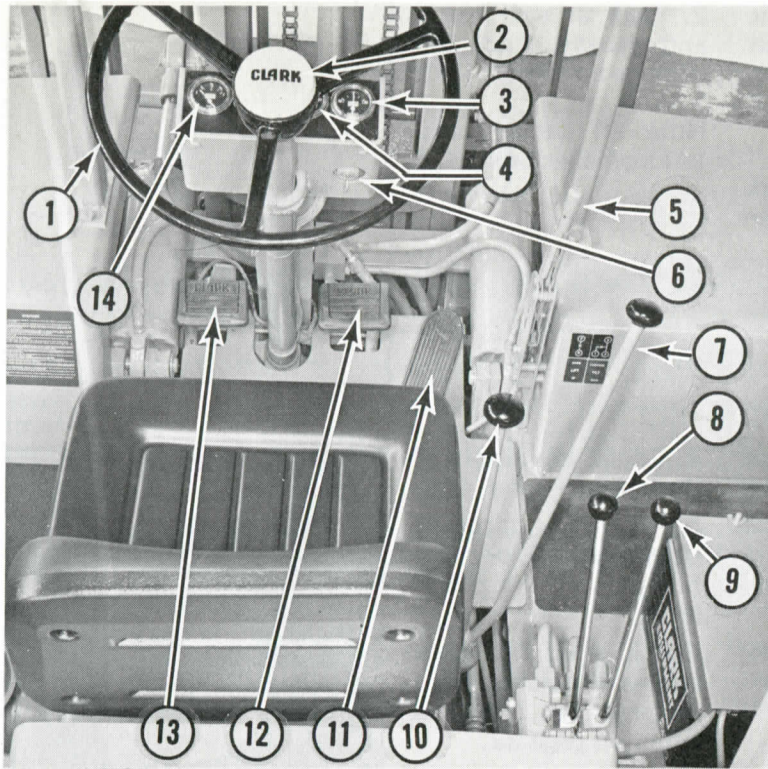

1. Steering handwheel
 2. Horn button
 3. Ammeter
 4. Engine oil pressure gauge
 5. Parking brake lever
 6. Key switch
 7. Transmission range shift lever
 8. Upright lift-lower control lever
 9. Upright tilt control lever
 10. Transmission directional shift lever
 11. Accelerator pedal
 12. Truck service brake pedal
 13. Clutch pedal
 14. Fuel gauge
- Water temperature gauge (located to right of fuel gauge)
 - Hour meter (located on front of hood at operator's right side)
 - Choke control (located on left hand side of operators seat support)

16758

Before Operation



1. Each shift operator must complete an operator's daily check list at the beginning of his shift.

These daily check lists are available from your Clark dealer.

2. Walk around truck and visually check for damage and leaks.

Note all damage and leaks on check list.



15197

16757



3. Check condition of drive wheels and tires. Note any apparent drive wheel or tire damage on the check list.

Check drive tire pressure and adjust, if necessary, to pressures listed on page 32.

4. Check condition of steer wheels and tires. Note any apparent steer wheel or tire damage on the check list.

Check steer tire pressure and adjust, if necessary, to pressures listed on page 32.

16786

16761

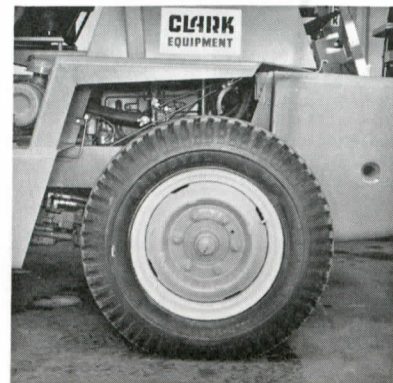

Before Operation



16737

16727

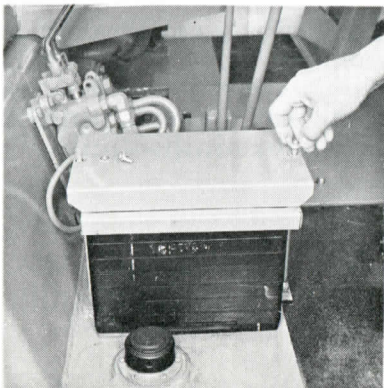

5. Check condition of overhead guard and load backrest extension.

Make certain that they are undamaged, properly positioned and mounted securely.

7. Remove fluid level plugs from all battery cells and check fluid level in each. Add distilled battery water as necessary. Replace all battery cell plugs.

Replace battery cover and secure with wing nuts.

6. Remove battery cover and check general condition of battery, battery terminals and cables.

Note condition of these items on your check list.

8. Unlatch hood and raise it to full open position.

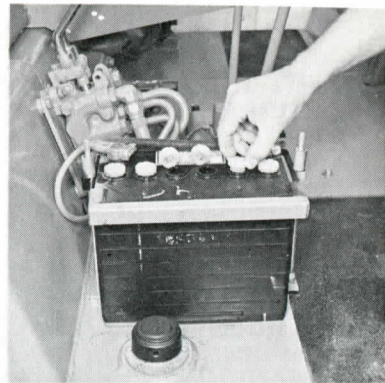

16726

16734

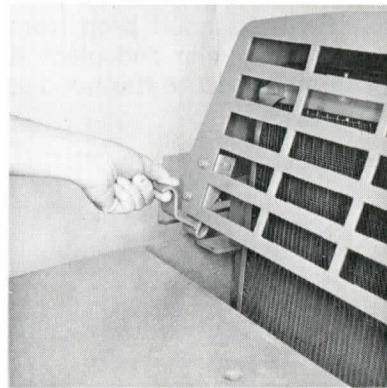

Before Operation



16733

9. Free the hood prop from its retaining clip and place it in position to secure the hood at "full-open".

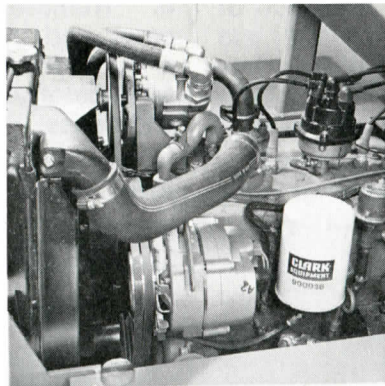

16756

10. Visually check general condition of engine compartment.

Check the condition of fan belt, wiring, hoses, fittings and note your findings on the Daily Check List.

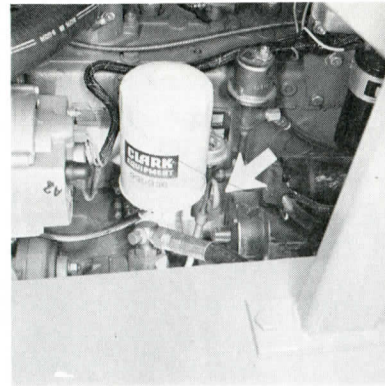

16755

11. Pull engine oil dipstick from its support tube. Wipe dipstick with a clean, lint-free cloth and re-insert dipstick fully into its support tube.

Before Operation

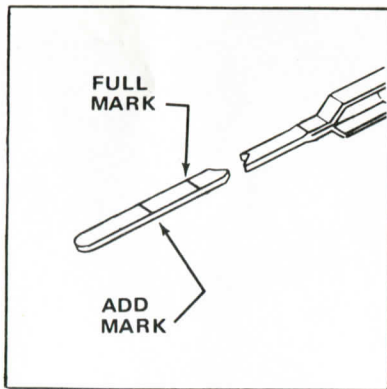

13239

16730



12. Pull dipstick from support tube and check engine oil level.

Engine oil level must be maintained between the "add" and "full" marks on the dipstick.

Remember that one quart of oil will raise the level from "add" to "full". DO NOT OVERFILL.

13. Wipe the dipstick once again with a clean, lint-free, cloth and reinsert the dipstick fully into its support tube.

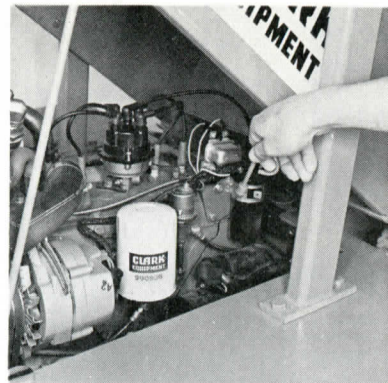

16754

14. Always check radiator coolant level with engine turned off and cold, if possible. **Caution** — Use extreme care when removing radiator pressure cap. The sudden release of pressure can cause a steam flash resulting in serious injury. Place a rag over the radiator cap and loosen slowly to allow gradual escape of steam.

Never add cold water or cold anti-freeze into the radiator of an overheated engine. Allow the engine to cool and avoid the danger of cracking the cylinder head or block. Keep engine running while adding water or anti-freeze. A solution of 50% ethylene glycol and 50% water is recommended — never use water only.

Remember to replace radiator cap and make certain that it is properly secured after check of radiator coolant level has been completed. Then return the hood prop to its "clip" and carefully close the hood. Make certain that the hood latches in the closed position.

Before Operation



15. Remove blocks from drive wheels, carefully enter operators compartment and seat yourself in the operators seat.

16735

16728

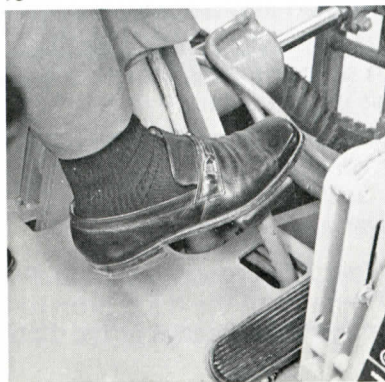

17. Place foot on service brake pedal and apply pressure by pushing down.

Pedal should be "firm". If pedal feels "spongy" or "fades" under pressure **DO NOT OPERATE THE TRUCK**. Report brake deficiency immediately to the proper authority.

Seat adjustment is accomplished by releasing short lever at lower right front of seat.

Position seat to provide easy access to all hand and foot controls, free lever and make certain that seat locks into desired position.

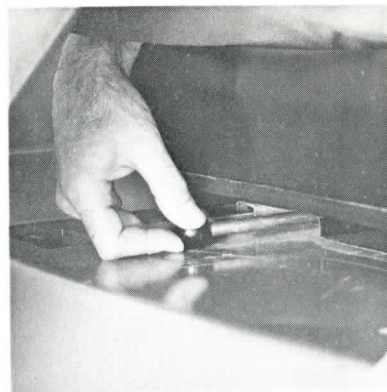

14969

13228

18. Make certain the parking brake lever is in the "on" (full-up) position.

Brake holding power can be adjusted by rotating the knob on top of the lever clockwise to increase holding power or counterclockwise to reduce it. (See page 32 of this manual for holding specifications).

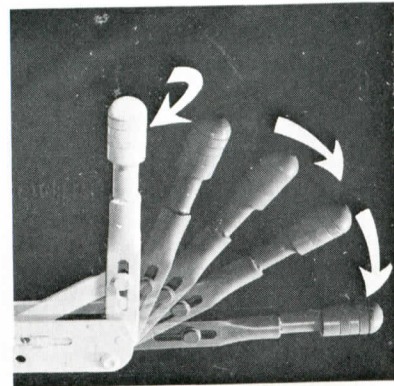

Before Operation



16753

19. Check to make sure that transmission directional control lever is in neutral position. These trucks are equipped with a neutral start switch and cannot be started in forward or reverse unless switch is faulty or improperly adjusted. Report switch condition on your check list.

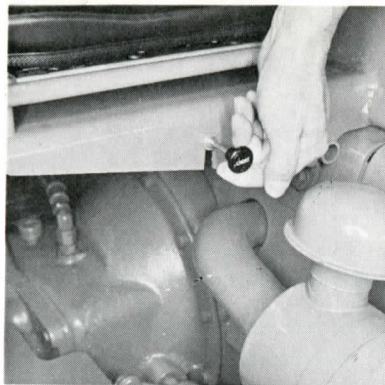

16738

20. Gas and L.P. gas trucks are equipped with a manual choke. This control must be pulled when starting a cold engine.

On L.P. gas models the choke should be pushed in as soon as the engine starts. On gas models the choke should be pushed in gradually as the engine begins to warm up once started.



16749

21. Place your right foot on the accelerator pedal and press down slightly.

Before Operation

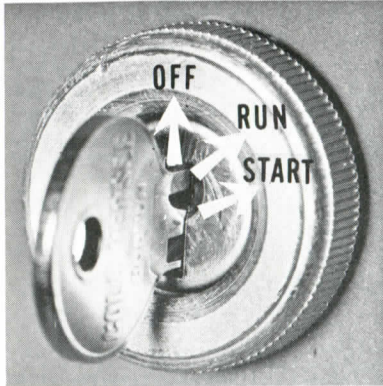

13226

22. Insert ignition switch key and turn clockwise to "start" position.

Release key to return to "run" position as soon as engine starts.

If engine does not start on the first attempt — do not re-engage the starter until the engine comes to a complete stop (approx. 5 sec).



16731

23. If gas or L.P. gas engine becomes overchoked or "flooded" in starting, push choke control in — press accelerator pedal to floor board and engage the starter as described in item 22.

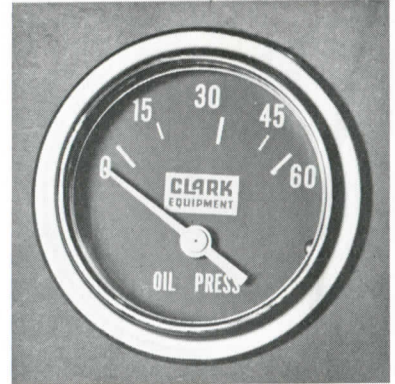

13222

24. Check the dash mounted engine oil pressure gauge to make certain that it is undamaged and operating properly.

The oil pressure should not drop below 7 PSI at idle. If oil pressure is erratic or if it drops below 7 lbs. you should stop the engine immediately.

Before Operation

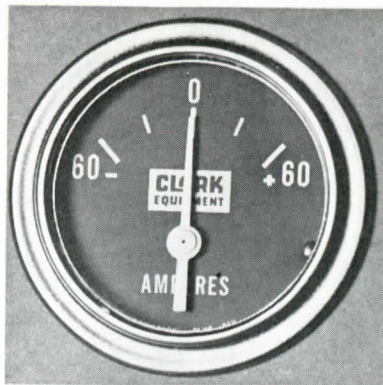

13224

25. Check the ammeter for proper operation. It should indicate a high rate of charge for a short period of time after the engine starts.

If the ammeter shows a continuous high rate of charge, discharge, reads erratically, or is otherwise damaged you should record these facts on your check list.

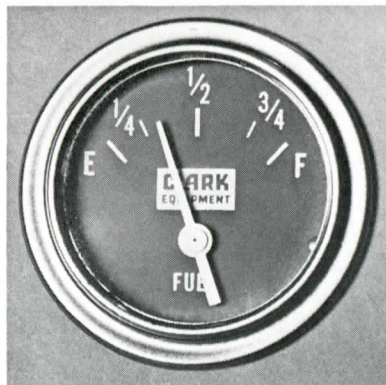

13220

26. On gas model trucks check the fuel gauge to determine the amount of fuel in the tank.

It is recommended that you always start your shift with a full fuel tank.

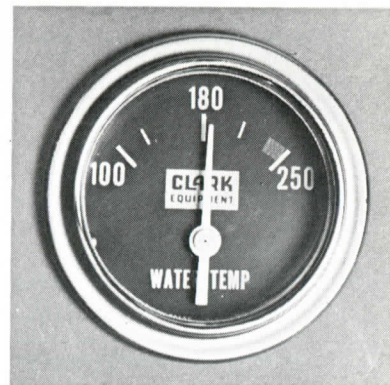

13223

27. Check dash mounted water temperature gauge to insure that it is undamaged and functioning properly. Water temperature should reach 180°F. after 10 minutes of operation.

If the indicator needle goes into the "hot" or red area during operation — immediately shut down the engine and do not restart until cause of trouble has been located and corrected.

Before Operation

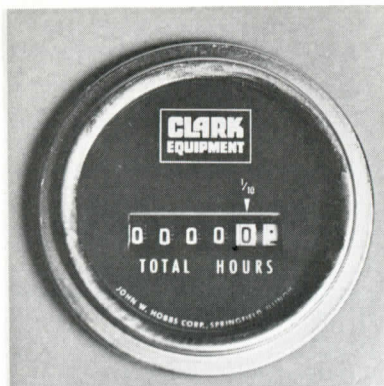

13225

28. The engine hour meter is mounted on the front of the hood at the operators right hand.

Make certain that it is undamaged and operating properly. Notice the total hours on the meter and record them on your Daily Check List.

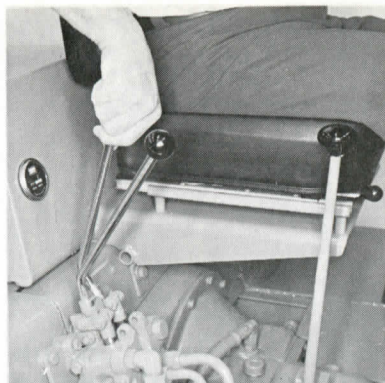

16752

29. Gently pull back on the tilt control lever and hold until upright reaches full back tilt.

Do not hold lever back after upright has reached full back tilt — to do so will unduly heat the hydraulic fluid and could harm the hydraulic system components.

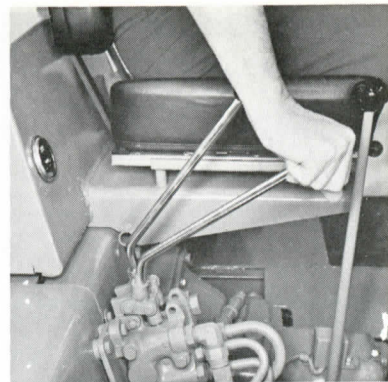

16744

30. Push tilt lever forward and hold in position until upright tilts forward to near vertical position.

Return tilt lever to neutral position to halt forward tilting action at desired point.

Before Operation



16751

31. Carefully check for adequate unobstructed overhead clearance, then gently pull back on lift control lever and hold until upright reaches maximum lift height.

Return lift lever to its neutral position to halt lift at desired level.

Note any erratic upright operation on your check list.

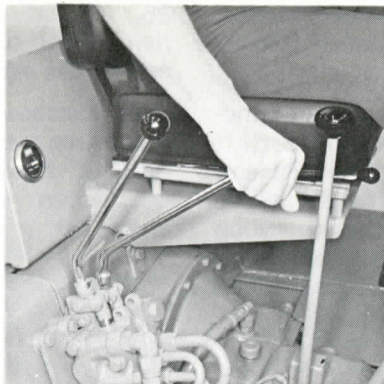

16743

32. Gently push forward on lift control lever and closely observe descent of upright carriage.

Return lift control lever to its neutral position to stop upright descent near (about 4-6 inches) floor level.

Record any erratic or unusual operation on your check list.

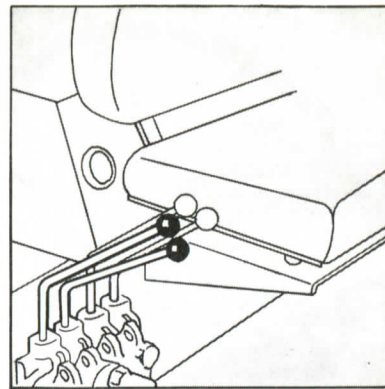

16787

33. Trucks equipped with hydraulic attachments or accessories will have one or more additional control levers mounted to the right of the lift and tilt control levers.

The function(s) of these levers should be checked with your supervisor before attempting operation.

Before Operation



13141

16750

34. Press horn button to determine if horn is operational.

If horn does not function properly record it on your check list and report it to the designated authority when you have completed your "before operation" checks.



36. Check all around truck to make certain that your desired path of travel is unobstructed.

35. Rotate steering handwheel to the left and to the right.

Any excessive or unusual free travel, looseness or binding must be noted on your check list.

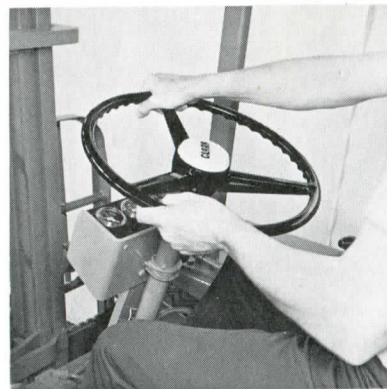

16736

16728

37. Place your right foot on the brake pedal and press down firmly to apply the truck service brakes.

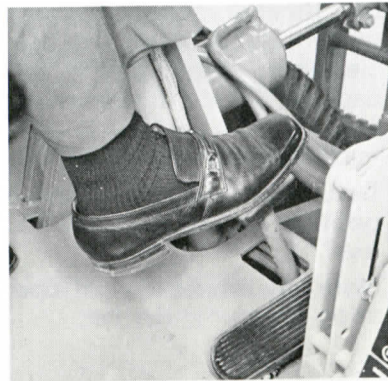

Before Operation

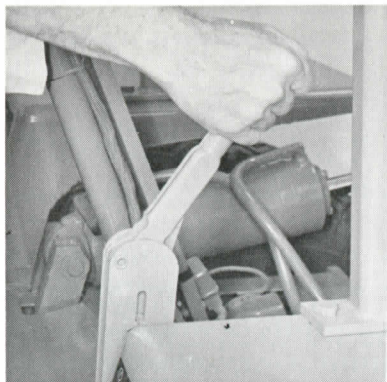

16739
16748

38. Release the parking brake by pushing forward on the brake control lever at your right hand side.

39. Place left foot on clutch pedal and apply downward pressure to disengage clutch.

This is a power assisted clutch and, should pedal effort increase during operation the truck should be stopped immediately.



16732
16749

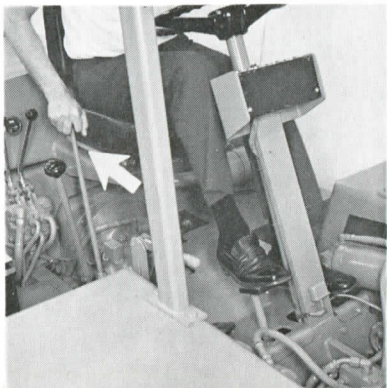

40. Place forward-reverse shift lever into proper position for desired direction of travel. (Pull lever back for reverse or push it forward for forward travel). Make certain that range selector lever is in low gear.

41. Release foot pressure on the brake pedal and place your right foot on the accelerator pedal.



Before Operation

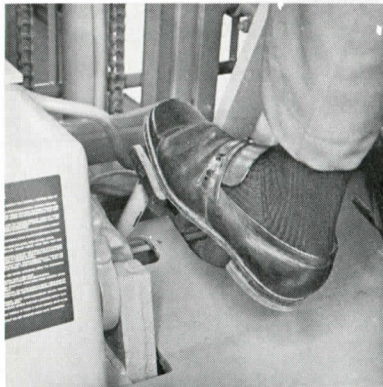

16746

16747

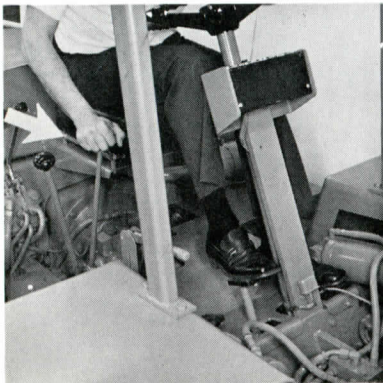

42. Slowly and smoothly engage (release pedal) the clutch with your left foot and at the same time, gently push down on the accelerator pedal with your right foot until the truck begins to move . . .

44. Move forward-reverse shift lever for direction opposite that selected in item 40 and repeat steps 41, 42 and 43.

43. . . . Then release the accelerator pedal and place your right foot on the brake pedal, depress the clutch pedal with your left foot and apply pressure to the brake pedal to bring truck to a smooth stop.

45. Lower forks to floor, tilt upright forward to place fork tips on the floor, depress clutch, place directional control lever in neutral, release clutch and . . .



16728

16743

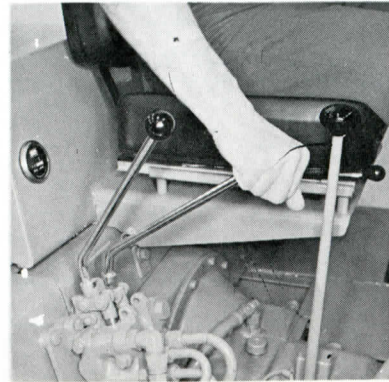

Before Operation



16739

46. ... Apply the parking brake, turn switch key counter-clockwise to "off" position, remove the key and . .

47. ... Carefully dismount from truck.

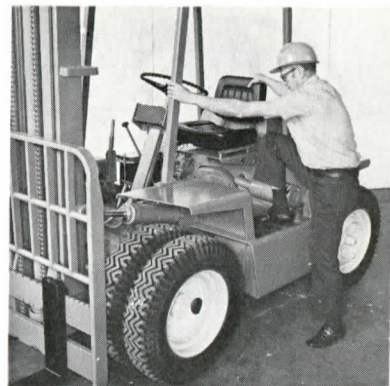

16741

16740



48. Block drive wheels to prevent accidental roll.

49. Review your check list to make certain that it is complete, sign it and turn it in to the designated authority.

15197

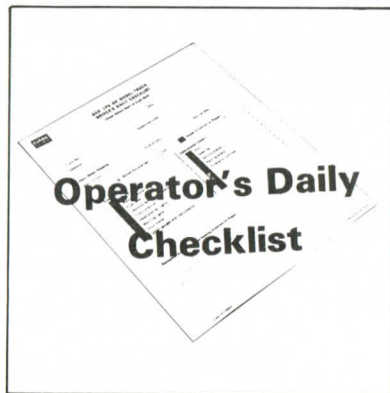

Operating Hints



14633

1. All models must be brought to a complete stop before shifting the directional control lever from forward to reverse or from reverse to forward.

- Always use low gear when starting, negotiating grades or ramps and when operating over rough or unimproved surfaces.

- Transmission speed ranges may be changed while traveling. When "up-shifting" these trucks it is necessary to fully depress the clutch pedal, shift to next higher gear and then release the clutch pedal with a smooth, steady motion while properly regulating engine speed to obtain maximum smoothness.

- These trucks should be "double clutched" whenever it becomes necessary to "down-shift" into a lower gear. Depress the clutch pedal fully,

move the range shift lever into neutral, release the clutch pedal, accelerate the engine. Depress the clutch pedal, shift into next lower gear and release the clutch pedal while regulating engine speed to obtain maximum smoothness.

- Selecting the correct drive gear ratio is a very important operators function. Choosing the proper gear for the job being done will result in better truck performance with longer engine and transmission life.

- If the operating surface is rough, or soft, or if grades or ramps must be negotiated, use the lowest transmission gear ratios available to you because — here power is needed — speed is not.

- As a general rule of thumb — DO NOT Lug the engine. Overworking the engine thru use of a "too high" gear ratio will create excessive heat and shorten component service life.

- When in doubt — use next lower gear.

Operating Hints

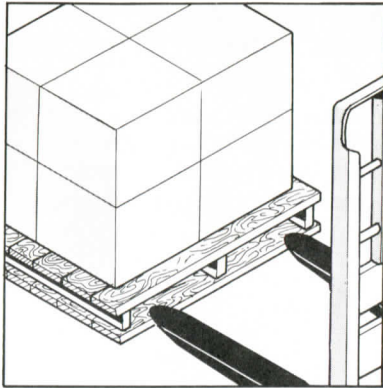

13203

10759

2. Remember to approach load slowly and squarely to avoid damaging the material being handled and to minimize truck maneuvering.

Load should be centered and forks should be near the outside edges to improve stability — if they are not . . .

3. . . Adjust them by lifting fork lock lever and sliding forks to the desired position then . . .

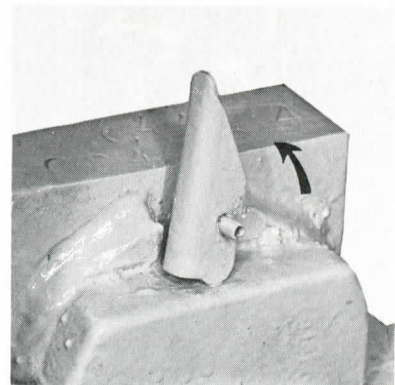

10758

16745

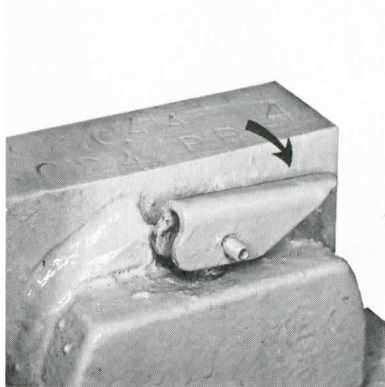

4. . . Remember to lower lever to lock forks securely into notch atop fork bar.

5. Always be alert for abrupt changes in the operating characteristics of your truck.

Unusual noises or sudden changes should be reported to your supervisor immediately.



Helpful Hints

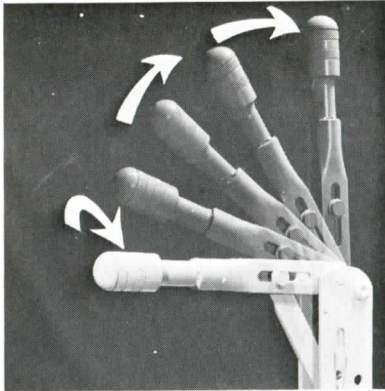

13228

Parking brake performance is checked by moving lever from full "on" position to full "off" position. Maximum force will be required just before brake lever reaches full "on" position.

The parking brake should be adjusted to hold the truck, with capacity load, on a 15% grade (1.5 feet of rise in 10 feet), or on the maximum grade negotiated in your operation, whichever is less. Brake holding power can be adjusted by rotating the knob on the lever. Rotate it clockwise to increase tension or counterclockwise to decrease tension and holding power.

GASOLINE

SPECIFICATIONS —
Fuel to be Automotive
Quality Regular Grade
Gasoline containing a
corrosion inhibitor.

Minimum Motor Octane
Number — 85

TYPICAL PRODUCT RECOMMENDED BY MAJOR BRAND OIL SUPPLIERS

Shell or Citgo Regular Gasoline
Sunoco 200 or Good Gulf Gasoline
American Regular Gasoline
Texaco Firechief Gasoline
ARCO or Mobil Regular Gasoline
. . . or the equivalent to the above.

TIRE PRESSURES

Tire Size	Ply	P.S.I.
7 x 17.5	6	45
8 x 17.5	6	45
12 x 16.5 (Lug)	8	50
12 x 16.5 (Hi-way)	8	50

Helpful Hints

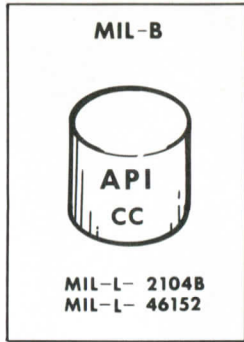

GAS — L.P. GAS ENGINE OIL
SPECIFICATION To meet API Service Classification "CC" and "SC" per SAE Report J183 and/or MIL-L-2104B. Sulfated ash content 1.00% weight maximum. Zinc content 0.06 to 0.10% weight maximum.

This specification includes oils meeting Specification MIL-L-46152 when applicable. Also, API Service "SC"/"SD" (Formerly "MS") oils may be preferred under stop-and-go or light service conditions.

TYPICAL PRODUCT RECOMMENDED BY MAJOR BRAND OIL SUPPLIERS

Chevron RPM DELO Multi-Service Oil
Shell X-100 or Rotella, Rotella T
Sunfleet H.P. or Citgo C300 Motor Oil
ARCO Fleet X.H.D. Motor Oil or ARCO Fleet H.D.
Gulflube Motor Oil X.H.D.
AMOCO 200 Motor Oil
Texaco Havoline or URSA Extra Duty Motor Oil
Mobil Delvac 1100B or 1200 Series Motor Oil
... or the equivalent to the above.

● ENGINE CRANKCASE OIL

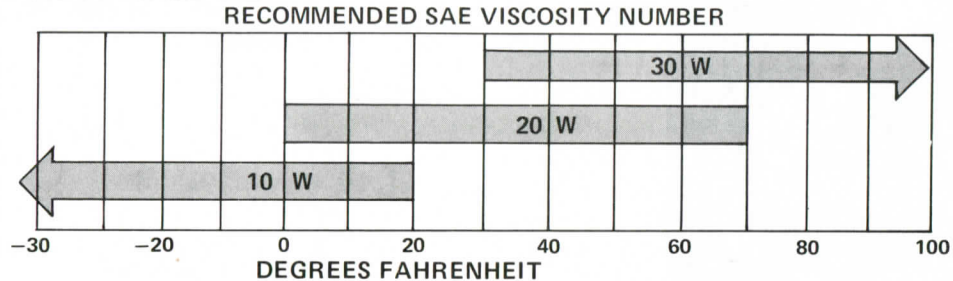

Parking

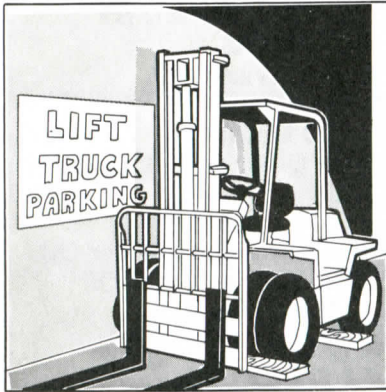

16775

16743

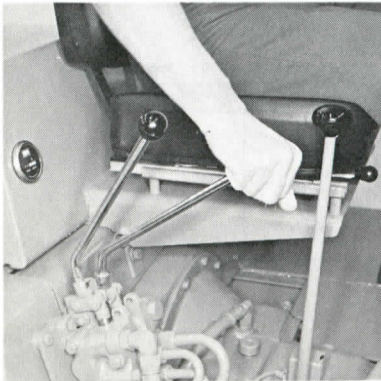

1. Park lift trucks only in designated parking areas.

Do not block aisles, exits, entrances or other emergency lanes.

3. Lower lift forks to floor.

2. Make sure that transmission directional selector lever is in neutral and that parking brake lever has been properly applied.

4. Tilt upright forward until fork tips rest on the floor.

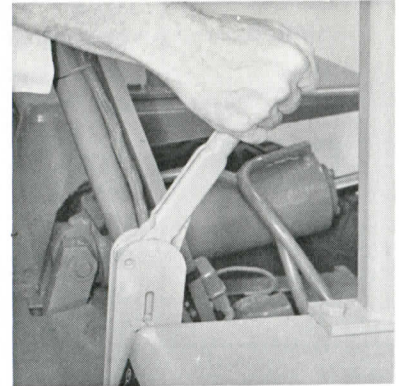

16739

16744

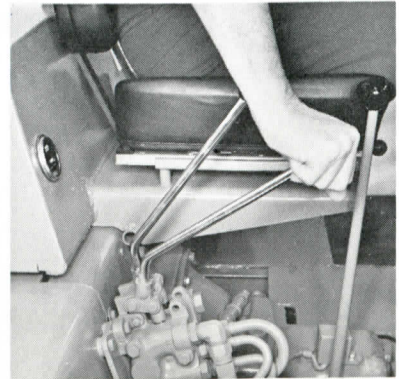

Parking

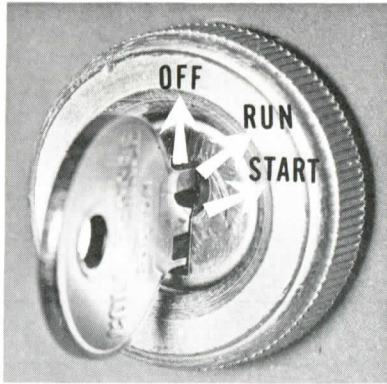

13226
16740



5. Turn ignition switch key counterclockwise to the "off" position and remove the key.

7. Securely block drive wheels to prevent accidental roll and turn the ignition switch key in to the designated authority.

6. Carefully dismount from the truck.



16741
10865

CAUTION

Place directional control lever in the reverse position, the speed shift lever in neutral and lock the shift levers before you attempt to tow this truck.

Failure to do this may result in major damage to drive line parts. Refer to your PMA Manual for added instructions.

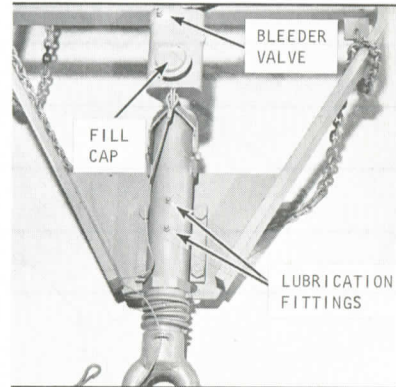

For Handy Reference

RECORD THE FOLLOWING INFORMATION PERTAINING TO YOUR TRUCK

Model _____

Serial No. _____

Attachments _____

Truck Weight (Empty) _____

Truck Rated Capacity _____

Gross Truck Weight (With Rated Load) _____

Transmission Type _____

Fuel Type (Gas, L.P. Gas or Diesel) _____

Tires (Pneumatic, Cushion) _____

Type Controls (Console or Column Mounted) _____

Customer Truck Identification _____

CLARK EQUIPMENT COMPANY
INDUSTRIAL TRUCK DIVISION
CUSTOMER SERVICES
BATTLE CREEK, MICHIGAN 49016

Additional copies of this manual may be purchased from:

**YOUR AUTHORIZED CLARK
DEALER**