Operator's Instruction Manual



C500(Y) 100 thru 150

CLARK

Book No. 2385901
OI-335, 2nd REV.



WARNING

**FOR YOUR SAFETY AND THE
SAFETY OF OTHERS**

BEFORE YOU OPERATE THIS TRUCK!

**READ ALL WARNINGS AND INSTRUCTIONS IN THE
OPERATOR'S MANUAL AND ON THE TRUCK.**

CHECK THE TRUCK FOR CORRECT OPERATION.

**DO NOT OPERATE THIS TRUCK UNLESS YOU ARE
TRAINED AND AUTHORIZED TO DO SO.**

IMPORTANT

Do not expose this manual to hot water or steam.

FOREWORD

Federal and state laws require that operators be completely trained in the safe operation of lift trucks.

Before you start operating this lift truck, make sure that you understand all driving procedures. It is important to operate your lift truck safely and efficiently.

This manual will help you learn how to operate your lift truck. This manual describes the controls, special features and the functions of each control.

This manual is not a training manual, it is a guide to help authorized operators safely operate a lift truck. Illustrations in this manual show the operator correct procedures for checking, starting, operating and stopping the lift truck.

Clark lift trucks are built to take hard work, but not abuse. They are built to be dependable but as with any lift truck, they are only as efficient as the operator and the persons responsible for maintaining them.

Do not make any repairs to this truck unless you have been trained in lift truck repair procedures and authorized by your employer.

MANUALES DE INSTRUCCION PARA OPERADORES IMPRIMIDOS EN ESPAÑOL SON OBTENIDOS DE SU DISTRIBUIDOR CLARK.

BETRIEBSANWEISUNGEN IN DEUTSCHER SPRACHE KOENNEN SIE BEI IHREM CLARK-HAENDLER ERHÄLTEN.

MANUELS DE L'OPERATEUR EN LANGUE FRANCAISE PEUVENT ETRE COMMANDES CHEZ VOTRE DISTRIBUTEUR CLARK.

TABLE OF CONTENTS

Operator's Warning	Page i
Foreword	Page ii
Drive Safely	Page 1
Summary of Safe Operating Procedures	Page 2
Truck Portraits	Page 4
Safety	Page 5
Know Your Truck	Page 15
Data and Capacity Plate	Page 15
Major Components	Page 16
Controls	Page 17
Instruments and Gauges	Page 19
Hand Controls	Page 21
Hydraulic Controls	Page 22
Transmission Controls	Page 23
Operating the Hydratork Transmission	Page 24
Operating the Manual Shift Transmission	Page 26
Using the Range Lever	Page 27
Gear Selection	Page 28
Operator's Daily Checklist	Page 29
Engine Starting Procedure	Page 36
Gasoline and L.P. Gas	Page 36
Diesel	Page 38
Stopping and Parking	Page 40
Helpful Hints	Page 41
Fuel, Oil, and Tire Inflation Recommendations	Page 44
Wheel and Tire Maintenance	Page 45
Truck Tip-Over	Page 48
Jump Starting	Page 50
Truck Reference Data	Page 53

DRIVE SAFELY

BEFORE YOU OPERATE THIS INDUSTRIAL TRUCK, READ AND UNDERSTAND THE INSTRUCTIONS, SIGNS AND MESSAGES IN THIS MANUAL AND ON THE TRUCK.

INJURY OR DEATH TO YOU OR OTHER PERSONNEL WILL OCCUR IF YOU DO NOT FOLLOW THESE INSTRUCTIONS AND MESSAGES.

STAY ALERT!

SUMMARY OF SAFE OPERATING PROCEDURES

1. Do not operate this truck unless you have been trained and authorized to do so. Read all warnings and instructions in operator's manual and on this truck.

2. Do not operate this truck until you have checked its condition. Give special attention to Tires, Horn, Lights, Battery, Controller, and Lift and Tilt Systems including forks and attachments, chains, cable and limit switches, brakes, steering mechanism, fuel system, and guards.

3. Operate truck only from designated operating position. Never place any part of your body into the mast structure, between the mast and the truck, or outside the truck. Do not carry passengers.

4. Do not operate truck without overhead guard, unless conditions prevent use of a guard. Use special care if operation without overhead guard is required.

5. Do not handle loads which are higher than the load backrest or load backrest extension unless load is secured so that no part of it could fall backward.

6. Do not handle unstable or loosely stacked loads. Use special care when handling long, high or wide loads to avoid losing

the load, striking bystanders, or tipping the truck.

7. Do not overload truck. Check capacity plate for load weight and load center information.

8. Lift trucks will tip over if not properly operated. Start, stop, travel, steer and brake smoothly. Slow down for turns and on uneven or slippery surfaces that could cause truck to slide or overturn. Use special care when traveling without load as the risk of overturn is greater.

9. Elevate forks or other lifting mechanism only to pick up or stack a load. Lift and lower with mast vertical or tilted slightly back — NEVER FORWARD. Watch out for obstructions, especially overhead.

10. Operate tilting mechanism slowly and smoothly. Do not tilt forward when elevated except to pick up or deposit a load. When stacking, use only enough backward tilt to stabilize load.

11. Travel with load or lifting mechanism as low as possible and tilted back. Always look in direction of travel. Keep a clear view and when load interferes with visibility, travel with load or lifting mechanism trailing (ex-

cept when climbing ramps).

12. Use special care when operating on ramps; travel slowly, and do not angle or turn. When truck is loaded, travel with load uphill. When truck is empty, travel with lifting mechanism downhill.

13. Observe applicable traffic regulations. Yield right-of-way to pedestrians. Slow down and sound horn at cross aisles and wherever vision is obstructed.

14. When using forks, space forks as far apart as load will permit. Before lifting, be sure load is centered and forks are completely under load.

15. Do not allow anyone to stand or pass under load or lifting mechanism.

16. Do not lift personnel on the forks or on a work platform. Use a manlift specifically designed for this purpose. When operating rider order selector trucks, attach the safety chain to the overhead guard and put the safety belt on.

17. Do not operate any truck with wet or greasy hands.

18. If a truck must be parked on an incline, put blocks at the wheels.

SUMMARY OF SAFE OPERATING PROCEDURES (Continued)

19. Make sure your truck is the correct fire safety type for the area in which you are working. The correct type designation for the truck is on the nameplate. In hazardous areas, use only trucks approved for use in those areas. Hazardous areas have classification markings.

20. When attachments are used, extra care must be taken in securing, positioning, and transporting the load. Operate trucks equipped with attachments as partially loaded trucks. Handle only loads within the capacity of the truck and attachment. Check the capacity plate for weight information.

21. If the upright malfunctions or becomes stuck in a raised position, operate the lift control to eliminate any slack lift chains. Do not go under the forks or carriage to make repairs.

22. Only specifically authorized and qualified persons should make repairs and adjustments to the truck.

23. Report all accidents involving personnel, building structures, and equipment to the correct authority.

24. Before getting off truck, neutralize travel control, fully lower lifting mechanism and set parking brake. When leaving truck unattended, also shut off power.

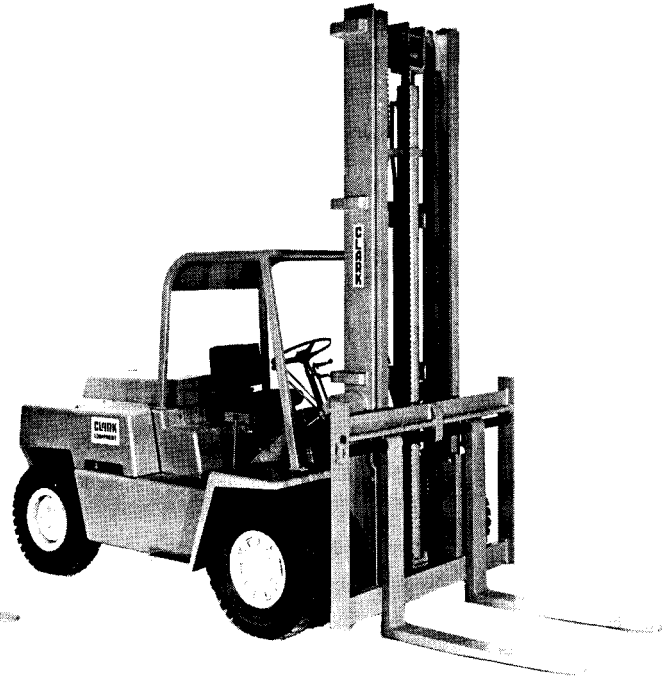

CLARKLIFT MODELS WITH RATED CAPACITIES FROM 10,000 LBS. THROUGH 15,000 LBS.
Pneumatic or cushion tires; Hydratork[®] (power shift) or Hydracool[®] (manual shift) transmissions. Choice of Gas, LP Gas, or Diesel engines.

Safety

BE A PRO!

Like any professional you must be thoroughly trained to operate a fork truck. Your ability to prevent accidents is an important part of your job.

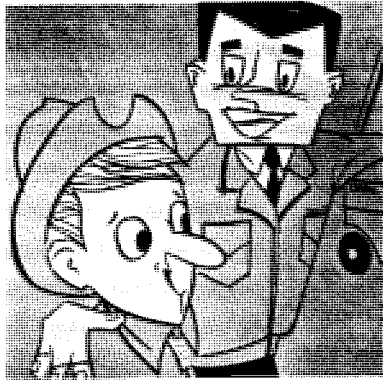

KEEP YOUR FORKS DOWN!

One of the first things you must learn is never to drive your lift truck with the forks raised. You might hurt someone or damage valuable merchandise.



LEARN YOUR JOB!

Practice turning, backing down ramps, operating in narrow confines, stacking. Develop confidence in yourself and your equipment.

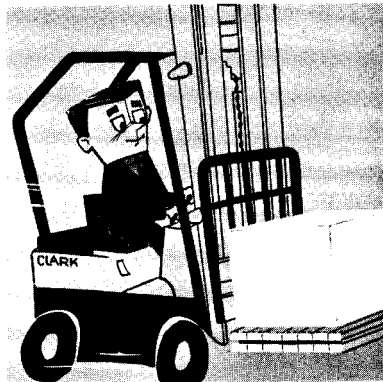

OBEY THE LAW!

Observe regular traffic rules. Keep to the right; don't follow too close; keep your truck under control and avoid sharp turns. Turning and high speeds can be dangerous.

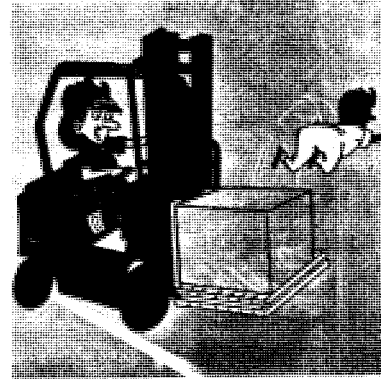

Safety

IF YOU CAN'T SEE, BACK UP!

If a load is too high or too wide to see around, drive the lift truck backwards. But take it easy, and watch for people and obstructions on both sides.



LOOK UP!

Keep an eye overhead . . . you can damage sprinkler systems and pipes. This isn't the time or place for a shower.



CHECK FLOOR CAPACITY

Be sure that elevators and floors in trucks and freight cars will support the combined weight of your truck and the load it is carrying.

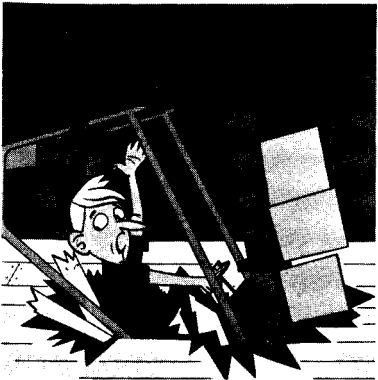

NO RIDERS... EVER

The quick response of a lift truck will cause riders to fall off. Besides, they distract you and this could be dangerous. Hang the "No Riders" sign right away.

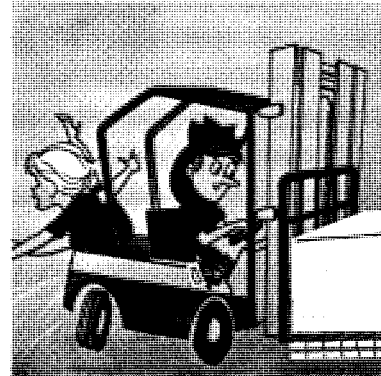

Safety



BE ALERT!

Obey all traffic signs and aisle markers. Slow down at aisle intersections and in crowded areas where people may step in front of you. Blow your horn at blind corners.

PROTECT YOURSELF!

An overhead guard is protection against personal injury. A load backrest extension helps protect the operator from spilled loads.

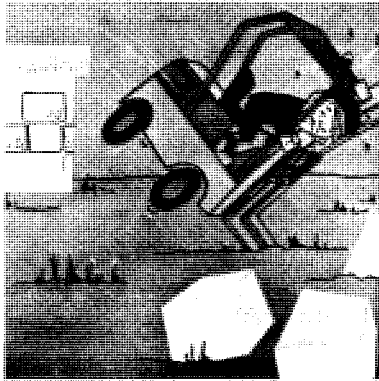
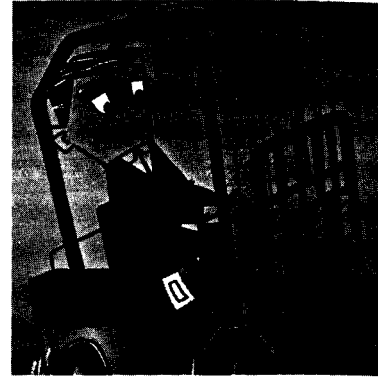

STAY CLEAR OF THE EDGE!

Stay away from the edge of loading docks. One little slip and you call for a medic.

SPACE FORKS TO FIT LOAD

To maintain proper balance, load should be centered and forks should be near the outside edges. It's easy to make the move and may save a move to the hospital.

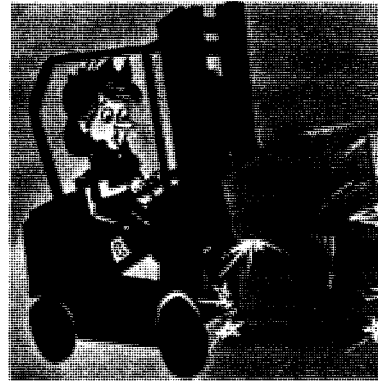

Safety

KEEP INSIDE!

Never drive a lift truck with your legs, or any other part of your body, outside the running lines of the truck.



NO SMOKING!

When refueling, never smoke or light a match. Shut off the engine and douse your cigarette. Always clean up spilled fuel before restarting engine.

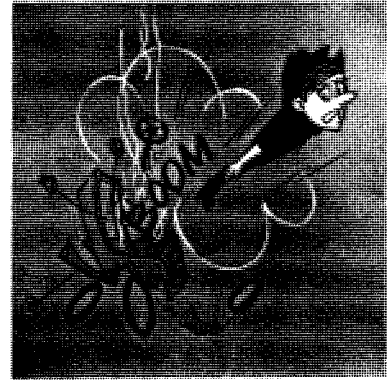

KEEP CLEAR!

Never put your head, hands or feet into the upright for any reason. Don't allow anyone to stand, walk or sit under the forks. Do not climb on upright or use it as a hand hold.

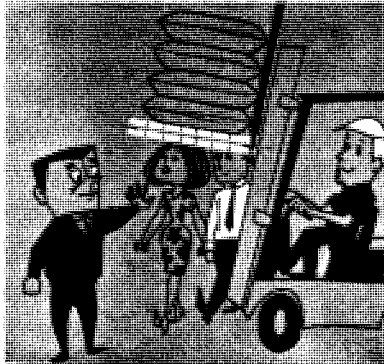

Do not use your lift truck to raise personnel.

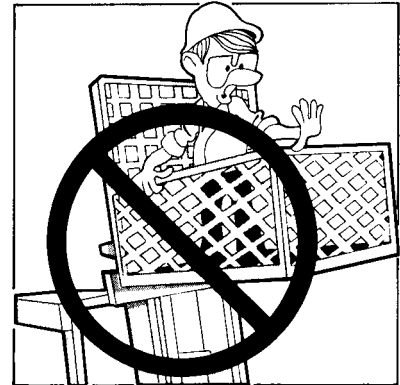

Safety



DON'T DAYDREAM!

Keep your mind on your work. Learn to anticipate danger before it arises.

CHECK YOUR PLATES!

Be sure bridge plates onto trucks and freight cars are properly in place and secure. Also, trucks and railroad cars should have their wheels blocked to prevent them from rolling.

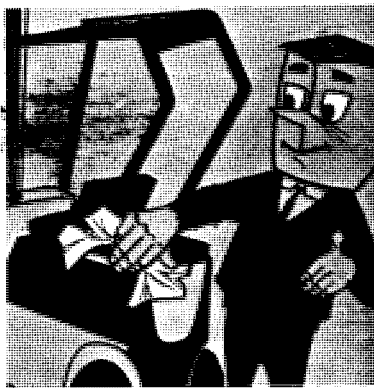

KEEP IT CLEAN AND READY TO GO!

Check gauges, horn, upright and controls before you start. Inspect fuel, oil and water levels. Take pride in operating a good, clean truck.

REPORT ALL TROUBLES!

Report faulty truck performance to your supervisor. Don't try to make repairs yourself.



Safety

HELP PREVENT ACCIDENTS!

When you park your machine, lower the forks so they're flat on the ground. Develop the habit; it's very important.

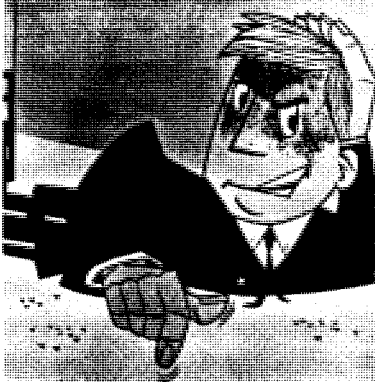

STOP, THEN BACK UP!

Always come to a full stop before reversing direction of travel. Your truck can reverse quickly, you can't.

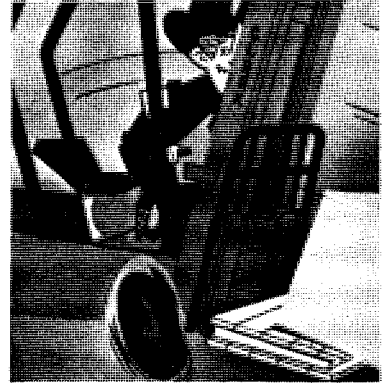

EASE INTO THE LOAD!

Don't blast into stacked goods; like a fullback. In fact, don't even nudge them with forks or rear end of truck — you might damage the goods and the operator.



DON'T LIFT UNSTABLE LOADS.

Obviously unstable loads should be repiled or banded. Once they are on the move, it's too late.

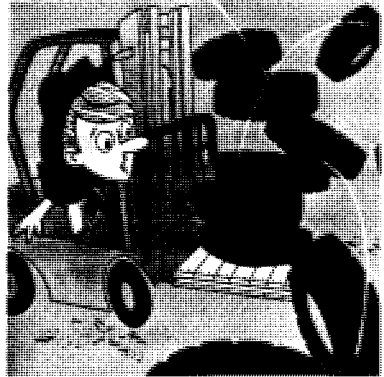

Safety



KEEP EYES FRONT!

Always remember the most important rule of the road: Look where you're going. Wandering eyes mean a wandering truck, and that could be dangerous.

BACK DOWN RAMPS!

It's risky to drive down a ramp load first. Your truck can tip forward if the ramp is steep enough. Always back down in low gear and never turn sideways on an incline.

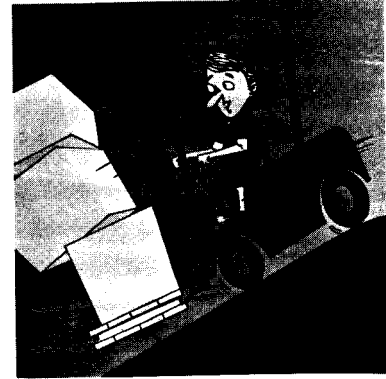

PICK UP ALL THE LOAD!

Be sure your forks are all the way under the load. A spilled load means lost production time as well as material damage.

TILT IT BACK!

Load should be tilted back until it rests securely for traveling. A load backrest extension gives added protection against spilling loads.

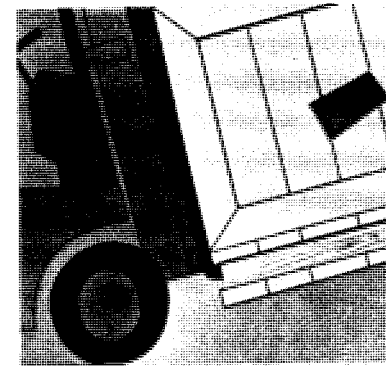
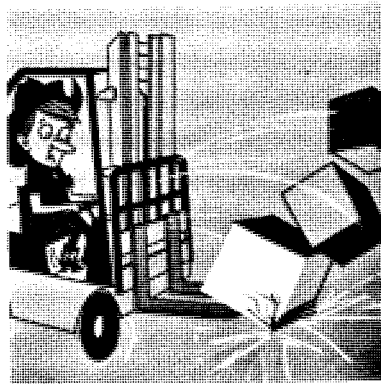

Safety

GET 'EM UP . . .

Raise loads just high enough to clear all floor obstructions.

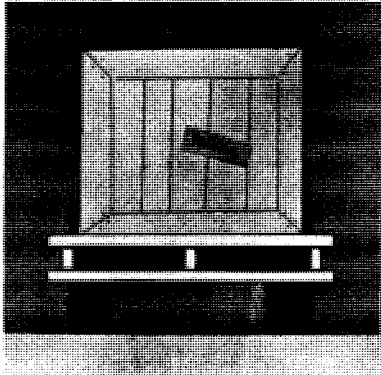

DON'T DOUBLE UP!

Don't handle double tiered loads. They're unstable and difficult to control. An overhead guard is designed to protect you against falling small packages, bagged material, etc. not a falling capacity load.

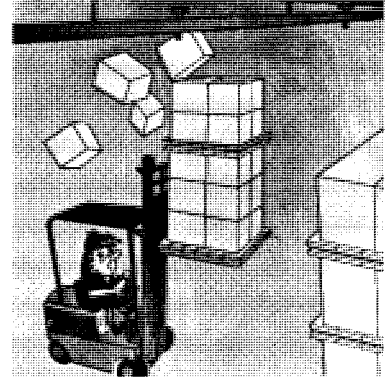

BREAK 'EM DOWN!

Overloading is extremely dangerous. You don't have complete control of your truck and you're causing unnecessary wear. Don't add counterweight, break down your load.

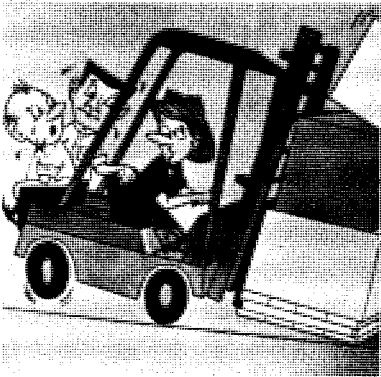

KEEP OTHERS OFF YOUR TRUCK!

Keep unauthorized people away from the controls of your truck. They could spoil a good safety record . . . fast.



Safety

DON'T BE HALF SAFE!

Under normal traffic conditions, keep to the right. Maintain a safe distance, based on travel speed, from the truck ahead and keep your truck under control at all times.

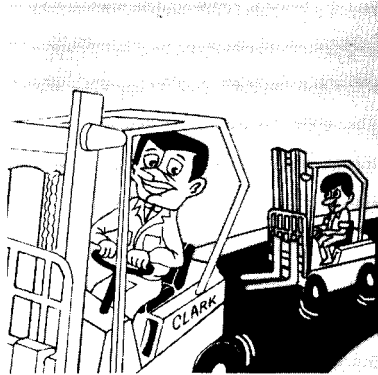

EASY DOES IT!

Do not pass another truck traveling in the same direction at intersections, blind spots, and other dangerous locations.

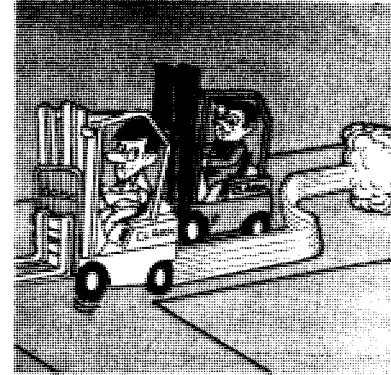

HOLD IT!

Slow down and sound horn at cross aisles and other locations where vision is obstructed. Yield the right-of-way to ambulances, fire trucks and other vehicles in emergency situations.

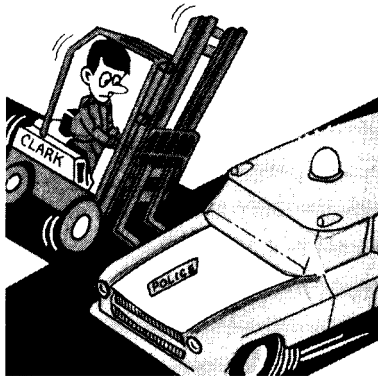

WATCH OUT FOR TRAINS!

Use of truck on public roads shall conform to local regulations. Cross railroad tracks at an angle wherever possible. Do not park closer than eight feet from center of tracks.

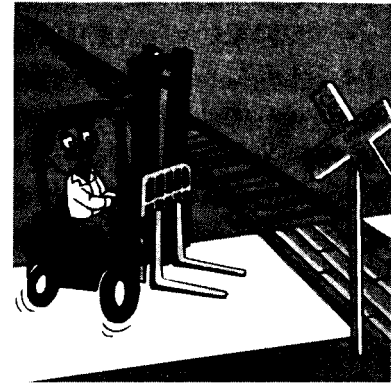

Safety

SLOW—FOR SAFETY TILT! YOU LOSE.

When operating surfaces are slippery due to rain, etc., slow down. Turning and high speeds can be dangerous.

Use minimum forward and reverse tilt when stacking and unstacking loads.

Never tilt forward unless load is over stack or at low lift height.

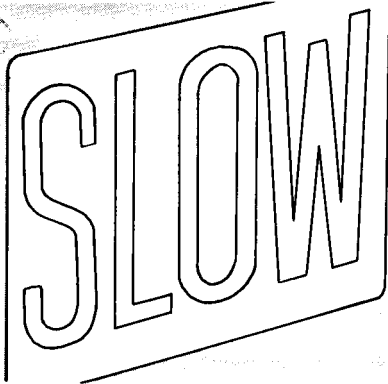
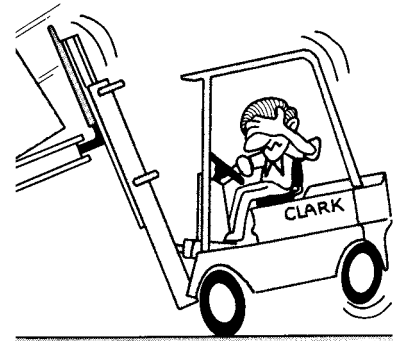

13103M
13110M

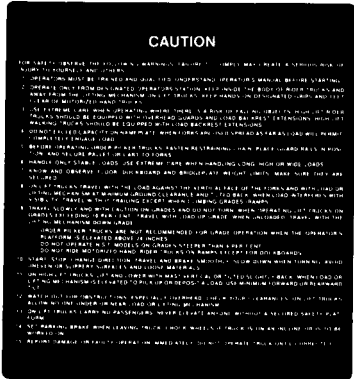

IT'S YOUR NECK

Prominently located on the truck is a list of basic safety rules. These rules are for your protection. Be familiar with them ... for your sake.

NOTE

Current models have a new operators warning, which replaces the caution decal shown. Read and understand the messages on the operators warning decal.

Know Your Truck

KNOW THE LOCATION OF YOUR TRUCK'S

**CLARK
EQUIPMENT**

INDUSTRIAL TRUCK DIVISION

MODEL NO.

SERIAL NO.

ATTACHMENTS

APPROX. WT. ALL TRUCKS

APPROX. WT. ELECTRICS ONLY

BATTERY CAPACITY

BATTLE CREEK MICHIGAN

TYPE

CAPACITY WITH ATTACH. LISTED ABOVE OR WITH FORKS - UPRIGHTS VERTICAL

LBS	A	B	C
<input type="text"/>	<input type="text"/>	<input type="text"/>	<input type="text"/>
<input type="text"/>	<input type="text"/>	<input type="text"/>	<input type="text"/>

LESS BATT - ELECTRICS

WITH MAX. BATT. WT.

MAX	MIN
<input type="text"/>	<input type="text"/>
<input type="text"/>	<input type="text"/>
<input type="text"/>	<input type="text"/>

FOR OTHER CAPACITIES - CONSULT MANUFACTURER AS RELEASED FROM FACTORY THIS TRUCK MEETS THE DESIGN SPECIFICATIONS ESTABLISHED IN AMERICAN NATIONAL STANDARD FOR POWERED INDUSTRIAL TRUCKS. PART II, ANSI B 56 1-1969

13217M

- ① MODEL NUMBER.
- ② TRUCK TYPE. The code letter(s) signifies type of fire protection construction. Check with proper authority before entering areas where inflammable or explosive material may be present.
- ③ SERIAL NUMBER.
- ④ ATTACHMENT DESCRIPTION (If any).
- ⑤ CAPACITY. Capacity, load center, and lifting height data are stamped in these areas. Do not exceed the maximum specified.
- ⑥ TRUCK WEIGHT LESS LOAD.

IMPORTANT: If the truck is modified so as to affect capacity; or, the plate damaged or defaced, get a new plate from your Clark Distributor.

DATA AND CAPACITY PLATE

Know Your Truck

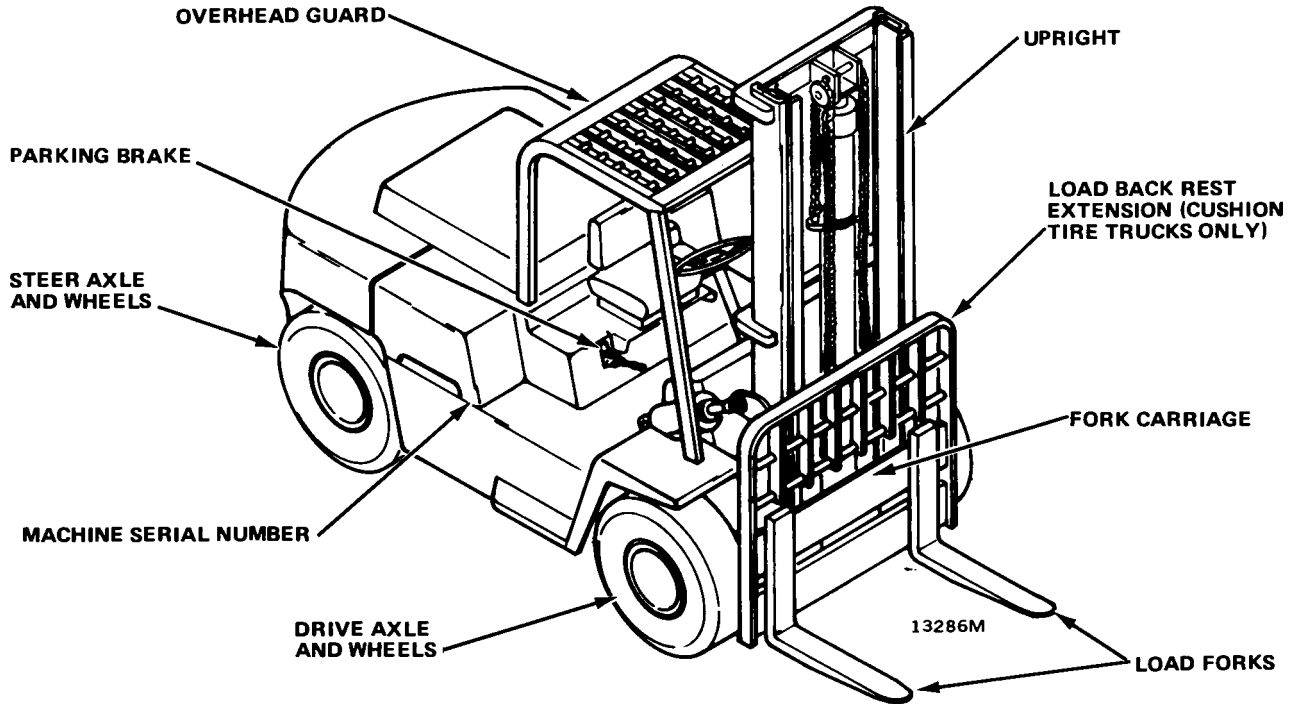

CLARKLIFT C500 MODELS
10,000 lb. THRU 15,000 lb. RATED CAPACITY

Know Your Truck

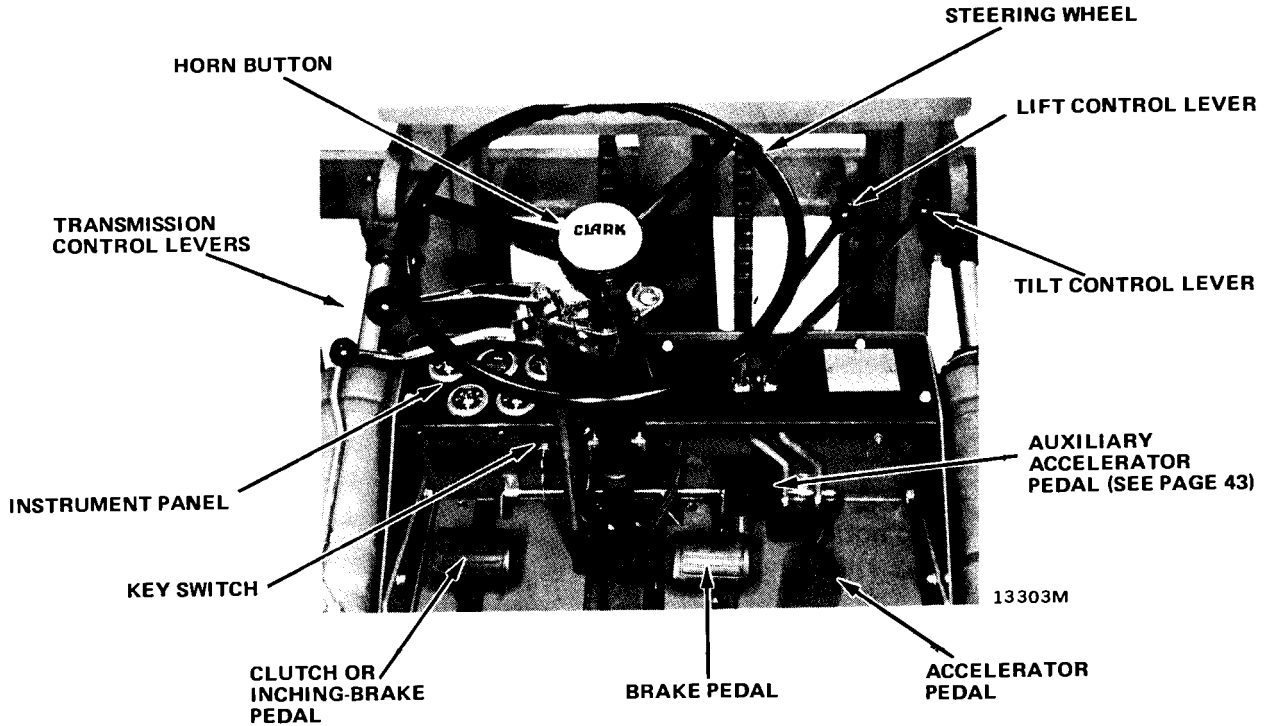

Know Your Truck

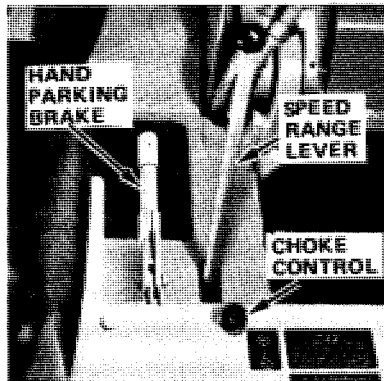

13287M
13288M

The parking brake and choke control are located beside the operator's seat. On trucks with Perkins engines, this is the normal stop control. On trucks with G.M. engines, this control should be used in emergency only.

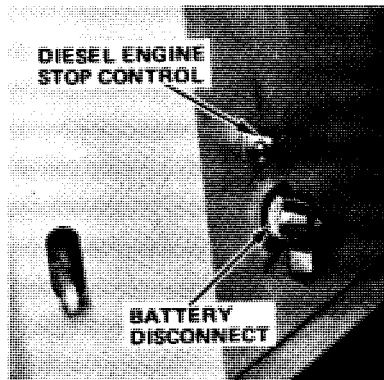

Cushion tire diesel trucks have an engine stop control and battery disconnect switch. The disconnect switch must be turned to the "off" position in case of fire or other emergency.

Pneumatic tire diesel trucks have an engine stop control located to the right of the operator's seat. On trucks with Perkins engines, this is the normal stop control. On trucks with G.M. engines, this control should be used in emergency only.

NOTE

Current model Perkins diesels use an electric solenoid engine shut-off.

The normal engine stop control on Pneumatic tire trucks with G.M. Diesel engines is located to the left of the driver's seat.

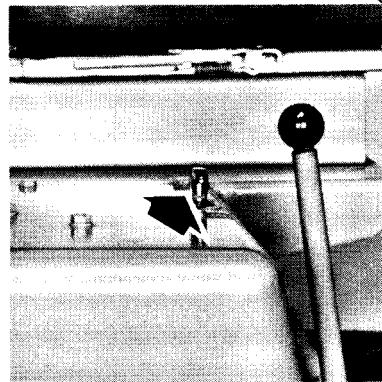

12091
13289M

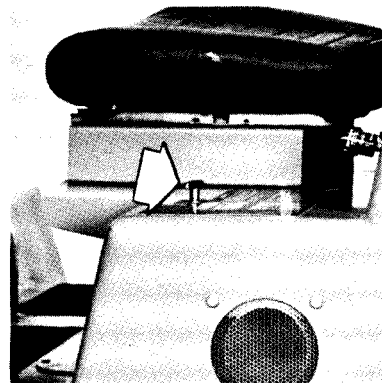

Know Your Truck

The instruments, indicators and hour meter, conveniently grouped in the instrument cluster, are designed to tell you at a glance many important things about the performance of your vehicle.

Familiarize yourself with their location and purpose and make it a practice to scan the instrument cluster as you start the engine . . . after it starts . . . and periodically as you drive.

NOTE:

The electrically operated indicators register correctly when the ignition switch is in the "on" position. When the ignition switch is turned "off", the indicator needle will not necessarily return to any given position.

Report to the designated authority if any indicator is not functioning properly.

GAS AND DIESEL FUEL GAUGE

Fuel level should be checked at the beginning of each shift. Always start with a full tank.

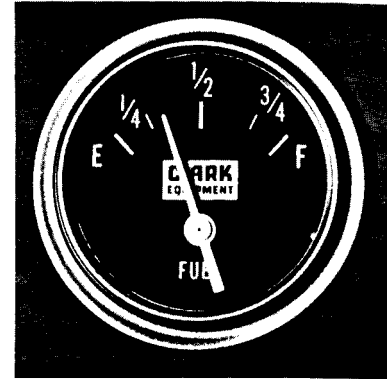

13220M
13221M

LP GAS FUEL GAUGE

The LP Gas fuel gauge is located at the end of the tank. Percentage of fuel remaining is indicated. Tank should contain enough fuel to complete scheduled work shift.

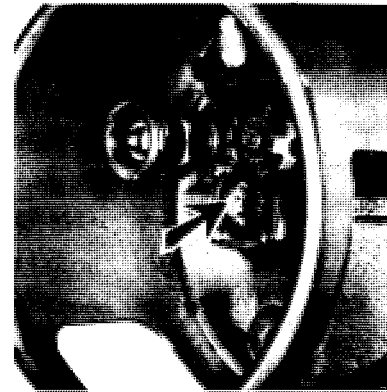

INSTRUMENTS AND GAUGES

Know Your Truck

OIL PRESSURE GAUGE

Oil pressure should be between 20 and 60 PSI at normal engine operating speeds. At idle, pressure should not fall below 5 PSI. If pressure is low (on some models indicated by a dash light) or erratic, shut down engine until trouble is located.



13222M
13223M

AMMETER

If the ammeter shows a continuous high rate of charge or discharge, or reads erratically, report trouble to proper authority.

NOTE: A high charge rate will be indicated for a brief time after engine is started.

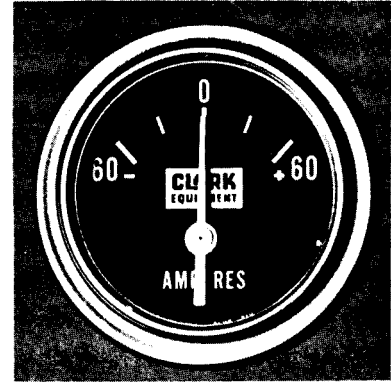

13224M
13225M

WATER TEMPERATURE GAUGE

Water temperature should be about 180°F. after 10 min. of operation. If the indicator registers in the "hot" zone, turn off engine until trouble is located.

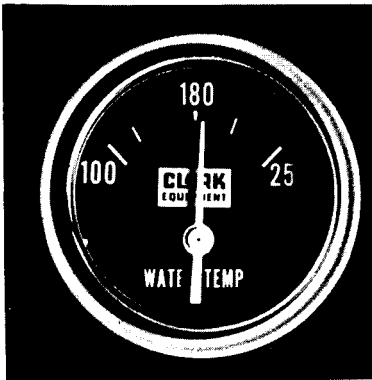

HOUR METER

Total engine operating hours are registered on the hour meter. The indicated hours are used for planned maintenance. The total hours should be recorded at the beginning and end of each shift on the Operator's Daily Checklist.



INSTRUMENTS AND GAUGES

Know Your Truck

KEY SWITCH

A 3 position key switch is standard equipment. To start engine, rotate key clockwise. Release to "run" position when engine starts.

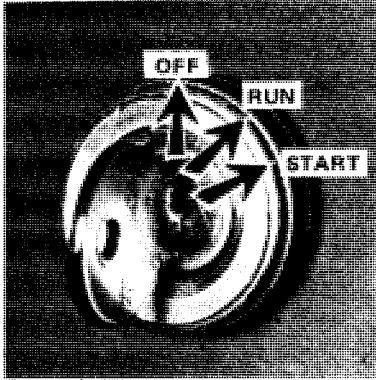

13226M
13290M

PARKING BRAKE

The parking brake should hold a fully loaded truck on a grade with an 18" rise in 10 ft. or the maximum grade negotiated in the operation, whichever is less. Tension can be regulated by rotating the knob on the lever.



13291M
11411

CHOKE CONTROL

The choke control is located next to the operator's seat. A choke control is not provided on Diesel models.

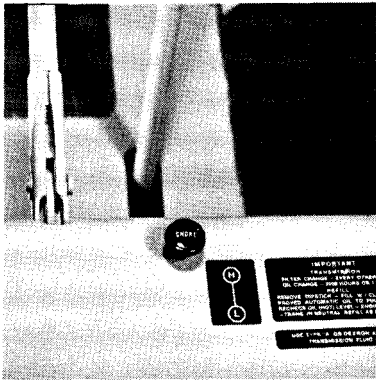

DIESEL ENGINE STOP

An engine stop control is provided on Diesel models. To stop the engine, allow it to idle for a few moments then pull out stop control. After engine stops, push control in and turn key switch to "off" position.

NOTE

Current model Perkins diesels use an electric solenoid engine shut-off.



Know Your Truck

The main hydraulic functions (lifting, lowering and tilting) are controlled by levers conveniently located to permit operation by the operator's right hand. THE LEVERS WILL AUTOMATICALLY RETURN TO NEUTRAL WHEN RELEASED.

Trucks equipped with hydraulic attachments or accessories will have one or two additional control levers mounted on the right hand side of the dash. The function of these lever(s) should be checked with the proper authority.

BE COMPLETELY FAMILIAR WITH ALL HYDRAULIC FUNCTIONS BEFORE OPERATING THE TRUCK WITH A LOAD. LEARN TO PERFORM THESE FUNCTIONS IN A SMOOTH MANNER.

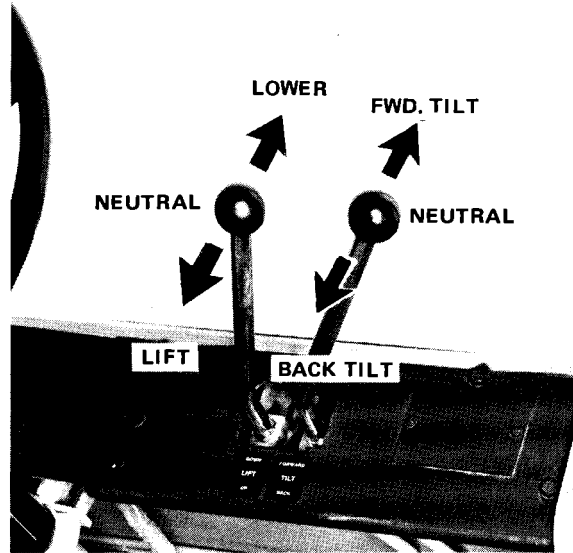

13292M

Know Your Truck

Your Clarklift is equipped with either a Hydratork (power shift) or Hydracool (manual shift) transmission. The manual shift transmission has a clutch plate that is oil cooled.

The Hydratork models have a left foot pedal to control inching and braking. The initial portion of pedal travel (approx. 1-1/2") regulates oil pressure within the transmission, thus allowing controlled truck speed independent of engine speed. Fast lifting and other hydraulic functions are possible while maintaining slow travel speeds.

Further depressing the inching-brake pedal actuates the service brake system. The right hand brake pedal controls service brakes only.

On manual shift models, the left pedal is for operating the clutch while shifting. Its operation is similar to that of an automobile.

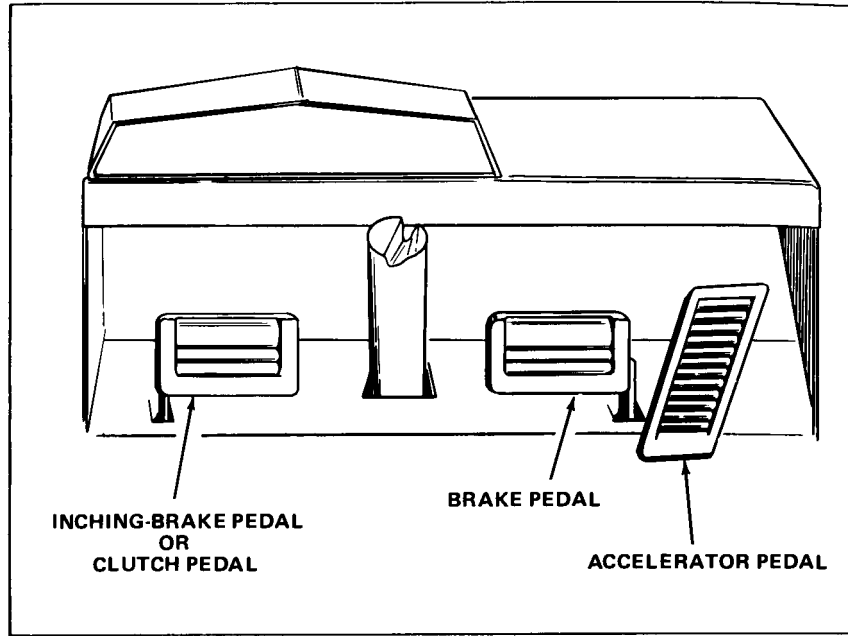

NOTE: Do not "Ride" the left foot inching-brake pedal as transmission component life can be shortened.

TRANSMISSION CONTROLS

Operating The Hydratork Transmission

The Hydratork is a power-shift transmission . . . not an automatic. It consists of a torque converter and hydraulically actuated selector packs. The selector packs eliminate the need for a clutch pedal. Each control lever position selects only one drive gear ratio.

Operating procedure is as follows:

1. Place forward-reverse control lever in the neutral position and start engine. (See engine starting procedure — pages 36, 38. The service brake pedal should be depressed.

NOTE: If the engine can be started with the control lever in a direction position, report to the proper authority.

2. Move forward-reverse lever to selected direction of travel. Change direction selector lever only when truck is stopped.

3. Select transmission speed position. It is recommended that low speed be used when starting, negotiating grades, and driving over unimproved surfaces. Then, change to higher speeds as conditions permit. Transmission speeds can be changed while moving.

Pneumatic tire trucks are equipped with a range lever for selecting drive line reduction. See page 27 for operating instructions.

NOTE: When changing speeds, learn to regulate engine RPM to minimize load jarring shocks. Decrease engine speed when changing from low to high and increase engine speed when changing to low.

4. Accelerate as required.
5. Inching with the left foot pedal is described on page 23.

Know Your Truck

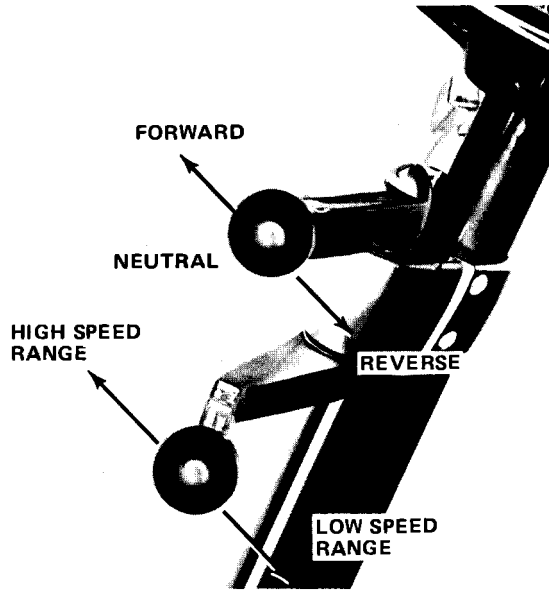

**HYDRATORK TRANSMISSION
SHIFT PATTERN**

13235M

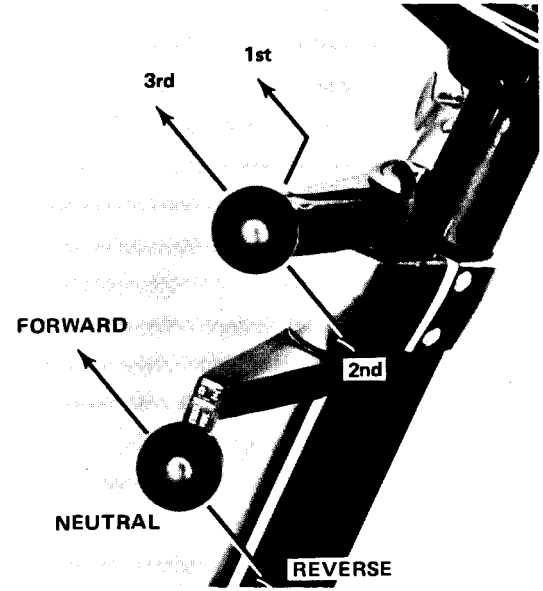

**HYDRACOOOL TRANSMISSION
SHIFT PATTERN**

13237M

Operating The Manual Shift Transmission

The manual shift transmissions are similar to automotive except two control levers are provided. One to select the direction of travel; the other to select operating speed range.

The Hydracool models have a power assisted clutch. The power assist functions only when the engine is running. If during operation a significant increase in effort to depress the clutch pedal is noticed . . . stop the truck immediately as serious damage to the clutch facings may result. Report condition to the proper authority.

Operating procedure is as follows:

1. Place forward-reverse lever in neutral and start engine. (See engine starting procedure – pages 36, 38. Hydracool transmissions are equipped with a neutral-start switch. If the engine can be started with the control lever in a direction position, report to the proper authority.
2. Depress clutch pedal. Move forward-reverse lever to the selected travel position.

3. Move speed range lever to select gear ratio that suits operating conditions. It is recommended that low gear be used when starting, negotiating grades, and when driving over unimproved surfaces.

4. Slowly engage clutch and accelerator as required. Then, change to higher speed range(s) as conditions permit.

Pneumatic tire trucks are equipped with a range lever for selecting drive line reduction. See page 27 for operating instructions.

5. Speeds can be changed while traveling except truck must be completely stopped when shifting into low. Depress clutch pedal when changing gears and release with a steady motion. Properly regulate engine speed to obtain maximum smoothness.

CAUTION: Always come to a complete stop when shifting to opposite direction of travel.

Know Your Truck

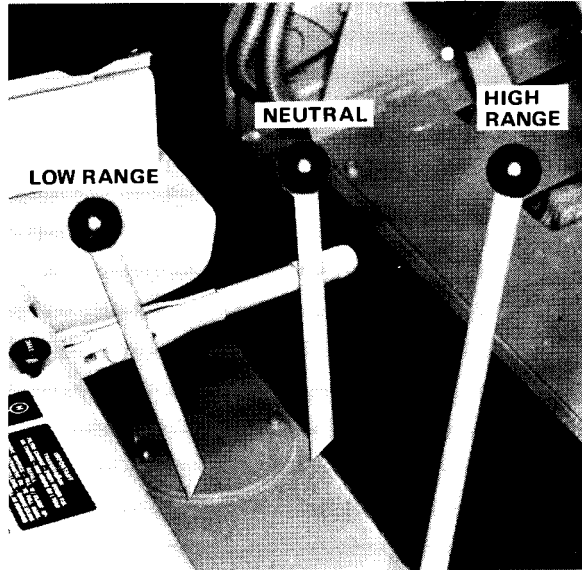

RANGE SELECTOR LEVER

13293M

Pneumatic tire trucks are equipped with a range selector lever. The lever is used to select a high or low drive line gear ratio.

In effect, the dual ranges double the available travel speeds. The Hydratork transmission has two speeds in each range: Total – four speeds forward and four reverse. Six speeds forward and reverse are available with the Hydracool transmission.

Changing from one range to the other can be done only when the truck is stopped. Depending on transmission type, either the inching-brake pedal or the clutch pedal must be depressed.

The correct speed-range combination depends on operating conditions. Page 28 lists some guidelines.

Know Your Truck

Selecting the correct drive gear ratio is an important driving function. Choosing the proper gear will result in better truck performance – longer engine and transmission life.

Three factors to help determine selection are:

- Type of surface: sand, mud, snow, hard or soft ground, concrete, rough, smooth, etc.
- Grades encountered.
- Long or short runs.
- Type and weight of load.

If the surface is soft and grades must be negotiated, use the lowest gear or combination of gears available. Here, power is needed – speed is not. Use the highest available gear when traveling over long distances on hard, level surfaces.

As a rule of thumb; do not lug the engine. Drive in the low range when traveling short distances. Start in a low gear and up-shift to the selected final speed. Overworking an engine and transmission will create excessive heat and damage components.

When in doubt – use the next lower gear.

Operator's Daily Checklist

One of your most important functions in making certain your lift truck is in safe and efficient operating condition is to make a quick and easy check at the beginning of your shift.

This should be viewed not only as a maintenance function, but also as a necessary step in doing everything possible to improve safety.

The Daily Checklist . . . available from your Clark Dealer . . . should be used to check out the truck . . . then make certain the report is given to your Maintenance Department (or to the designated authority). The various checks are as follows:

<input checked="" type="checkbox"/>	Boxes Accordingly	<input type="checkbox"/>	OK	<input type="checkbox"/>	Needs Attention or Repair
-------------------------------------	-------------------	--------------------------	----	--------------------------	---------------------------

Visual Checks:			Operational Checks:		
<input type="checkbox"/>	<input type="checkbox"/>	Engine oil level	<input type="checkbox"/>	<input type="checkbox"/>	Horn
<input type="checkbox"/>	<input type="checkbox"/>	Radiator water level	<input type="checkbox"/>	<input type="checkbox"/>	Steering
<input type="checkbox"/>	<input type="checkbox"/>	Fuel level	<input type="checkbox"/>	<input type="checkbox"/>	Service brakes
<input type="checkbox"/>	<input type="checkbox"/>	Obvious damage and leaks	<input type="checkbox"/>	<input type="checkbox"/>	Parking brake
<input type="checkbox"/>	<input type="checkbox"/>	Tire condition	<input type="checkbox"/>	<input type="checkbox"/>	Hydraulic controls
<input type="checkbox"/>	<input type="checkbox"/>	Head and tail lights	<input type="checkbox"/>	<input type="checkbox"/>	
<input type="checkbox"/>	<input type="checkbox"/>	Warning lights	<input type="checkbox"/>	<input type="checkbox"/>	
<input type="checkbox"/>	<input type="checkbox"/>	Hour meter	<input type="checkbox"/>	<input type="checkbox"/>	
<input type="checkbox"/>	<input type="checkbox"/>	Other gauges and instruments	<input type="checkbox"/>	<input type="checkbox"/>	

Operator's Daily Checklist

1. Engine oil level should be maintained between the "add" and "full" marks. The best time to check is before starting the engine or as the last item on the list. This allows accumulated oil to drain back into the crankcase. One quart of oil will raise the level from the "add" mark to "full".
2. Fuel level must be checked with the key switch in the "on" position. Gauge does not necessarily return to empty with switch "off".
3. Obvious damage and leaks. Check for leaks in the hydraulic system, engine and transmission oil, fuel, engine coolant, and power steering where applicable. If the truck has been standing for a length of time, inspect floor for fresh drippings.

4. Tire condition is important for safe operation of any vehicle. Remove all foreign material lodged in tires. Report to designated authority any deep cuts or gouges.

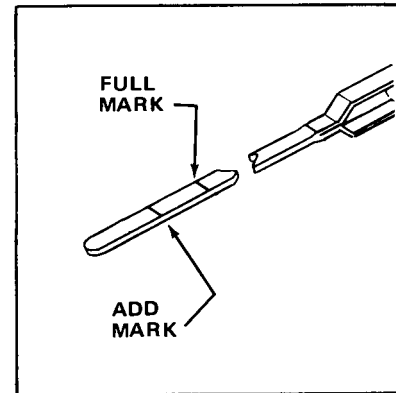

ENGINE OIL DIPSTICK

13239M

Operator's Daily Checklist

5. Always check radiator coolant level with the engine turned off. When possible with engine cold. Proper coolant level is one inch below the bottom of the filler neck.

Never add cold water or cold anti-freeze into the radiator of an overheated engine. Allow the engine to cool and avoid the danger of cracking the cylinder head or block. Keep engine running while adding water or anti-freeze. A solution of 50% Ethylene Glycol and 50% water is recommended. Never use only water.

CAUTION: Use extreme care when removing radiator pressure cap. The sudden release of pressure can cause a steam flash resulting in serious injury. Place a rug over cap and loosen slowly to allow gradual escape of steam.



**CHECK RADIATOR
COOLANT LEVEL**

13294M

Operator's Daily Checklist



**DIESEL AIR CLEANER
CONDITION INDICATOR** 13247M

6. Check all gauges and instruments at beginning of each shift and during operation. Perkins Diesel powered trucks are equipped with an air cleaner condition indicator. If the indicator registers red, the air cleaner must be serviced. The indicator can be reset by pushing the button on top.
7. Head and tail lights must function. Clean if necessary.

8. Check all warning lights and other safety devices.
9. Record hour meter reading on daily checklist.
10. Make sure horn is working properly . . . for safety.
11. Make a steering performance check . . . rotate hand wheel back and forth. Excessive travel, looseness or binding should be reported to the proper authority.

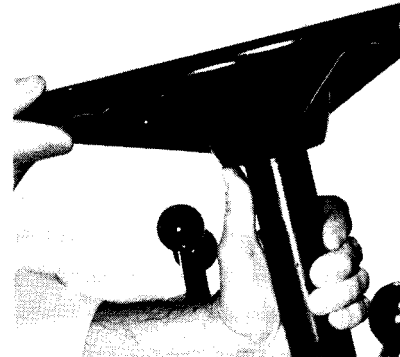

STEERING CHECK 9843

Operator's Daily Checklist

12. Service brake pedal should feel firm when depressed and not noticeably drift with pressure applied for 10 seconds.

On machines equipped with a Hydratork transmission, the same test should be applied to the left foot inching-brake pedal.

If a significant increase in pedal effort is required to stop the truck, report condition to designated authority.



PARKING BRAKE

13291M

13. Check parking brake performance by moving brake lever from full down to full up position. Maximum force is required just before full up (brake on) position is reached.

The parking brake should hold the truck with a capacity load on a 15% grade (1.5 feet rise in 10 feet), or the maximum grade negotiated in the operation, whichever is less. Brake holding power can be adjusted by rotating the knob on the lever. Rotating clockwise will increase tension; counterwise will reduce tension and holding power.

If performance checks are not satisfactory, report condition to designated authority.

Operator's Daily Checklist

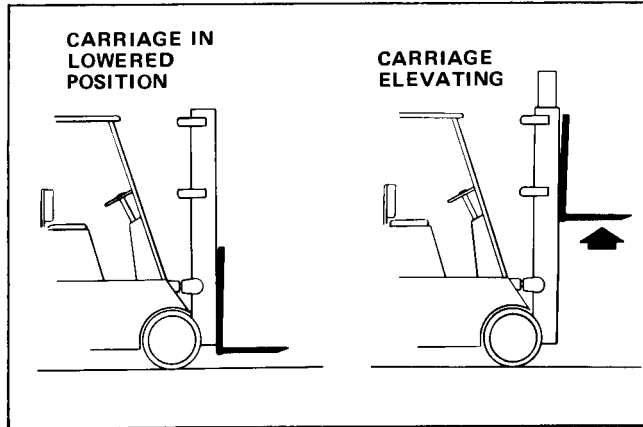

13243M

14. Check hydraulic functions with engine running. (Engine starting procedure is outlined on pages 36, 38.

All movements of upright and carriage should be smooth . . . without binding. Hydraulic control lever operations are described on page 22.

Tilt upright to full forward and back positions.

Raise carriage to maximum height. If carriage will not reach upper limit, a low hydraulic fluid level is indicated.

Report any unusual operating conditions or noises to the designated authority.

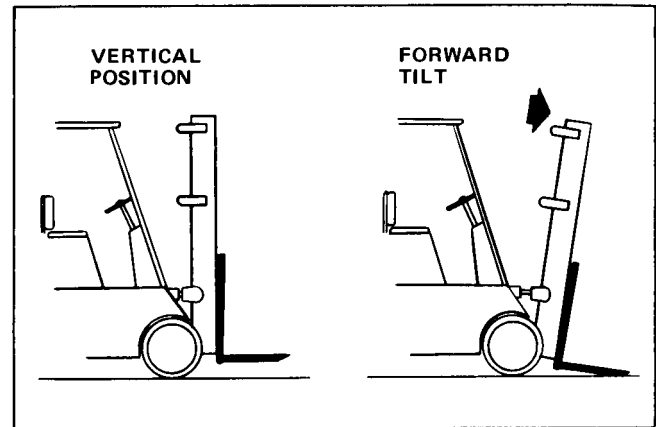

13244M

Engine Starting Procedure

Gasoline and L.P. Gas

1. Be sure that forward-reverse transmission control lever is in neutral and parking brake is applied.
2. On L.P. Gas units, open the shut-off valve slowly. If opened too quickly, an automatic safety check valve will close. It will then be necessary to close hand valve for several minutes and slowly open again.

The hand valve opens by turning counter-clockwise.

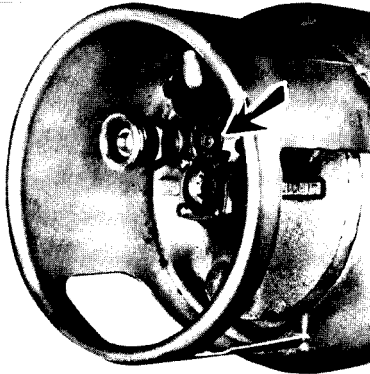

L.P. GAS
SHUT-OFF VALVE

13245M

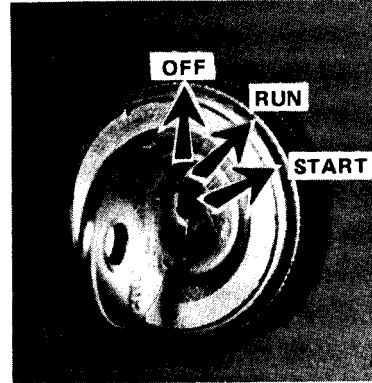

KEY SWITCH

13226M

3. Pull out on choke control.
4. Turn ignition switch key to "start" position to engage starter. Release to "run" position when engine starts.

CAUTION: If engine does not start on first attempt, do not restart until engine comes to a complete stop (about 5 seconds).

Engine Starting Procedure Gasoline and L.P. Gas

5. Push choke control in on gas engine as it warms up to normal operating temperature. The choke should be pushed in immediately after starting L.P. Gas engine.
6. If the engine becomes flooded, push choke control in and fully depress accelerator. Turn key switch . . . engine should now start.

7. With engine running, re-check all instruments and gauges to make sure they are operating properly. Especially note the engine oil pressure indicator. If pressure does not build up immediately, shut off engine and report condition to designated authority.

NOTE: Run engine for several minutes before operating to allow adequate lubrication to reach all moving parts . . . especially in cold operating conditions.

WORK SAFELY

DRIVE SAFELY

BE CAREFUL

Engine Starting Procedure

Diesel

1. Make sure engine "stop" control is in "run" position (pushed in).
2. Place transmission forward and reverse control levers in neutral.
3. Turn key-start switch to "start" position and hold for 15 seconds or until engine starts.
4. If engine does not start, turn key to "off" position and wait for engine to come to complete rest (about 5 seconds).
5. If engine does not start after three tries, air in the fuel system may be the cause. Refer to designated authority and consult P.M. Manual.
6. The Perkins Diesel has a cold starting aid, consisting of a manifold heater. If the weather is cold, depress the "heat-start" button for 15 seconds with the key in "run" position. Now crank engine by turning key to "start".
If engine does not start, repeat procedure holding "heat-start" button in for 10 seconds.

At temperatures below 0°F. (-18°C), depress button for an additional 10 seconds while engine is running.

If engine fails to start, refer to Step 5.

CAUTION: Do not attempt to start engine with fuel tank empty.

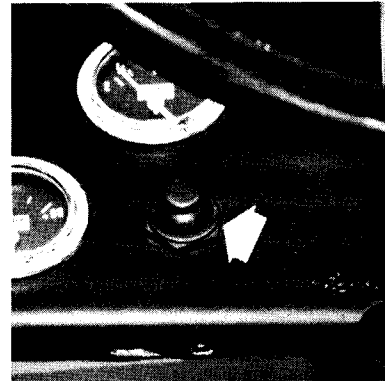

**FUEL HEATER BUTTON
PERKINS DIESEL**

13295M

ENGINE STARTING PROCEDURE DIESEL

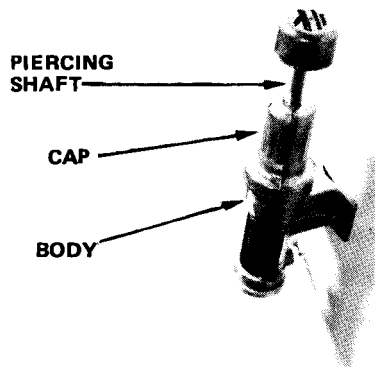

**G.M. DIESEL
STARTING AID**

13296M

- An optional cold weather starting device is available for the G.M. Diesel engine. Follow this procedure:
 - Unscrew cap from body and drop in starting aid capsule.
 - With piercing shaft pulled out, screw cap onto body snugly.
 - Push piercing shaft all the way in.
 - Fully depress accelerator pedal. Engage the starter.
 - While cranking the engine, pull pump plunger out and then push in slowly until engine starts. After engine starts, continue pushing plunger very slowly until it seats. See sample. – Remove capsule and reassemble with piercing shaft “down”.

- With engine running, re-check all instruments and gauges to make sure they are operating properly. Especially note the engine oil pressure indicator. If pressure does not build up immediately, shut off engine and report condition to designated authority.

NOTE: Run engine for several minutes before operating to allow adequate lubrication to reach all moving parts . . . especially in cold operating conditions.



STARTING AID PUMP

13297M

Stopping and Parking

1. Gasoline – Lower forks, or other engaging means, to floor with upright tilted slightly forward. Turn key switch to “off” position and set parking brake. Place transmission controls in neutral. Remove key if leaving truck.
2. L.P. Gas – same as 1. If truck is to be parked more than one hour, close manual shut-off valve at tank and continue to run engine until gas vapors in the system are used up. Then turn key to “off”.
3. Diesel – same as 1. Allow engine to idle for several moments before pulling out engine stop control. Be sure to push stop control in after engine stops. See page 18 for engine stop location.
4. Park trucks only in designated areas. Do not block aisles or other emergency lanes.
5. If truck must be left on incline, always block drive wheels to prevent accidental roll.
6. **WARNING:** It is recommended that LPG tanks be stored outside overnight. Only trained and designated personnel should handle LPG containers. Damaged containers can result in a serious accident.
7. The storage and handling of liquid petroleum gas fuel shall be in accordance with the recommendations of the local authority having jurisdiction.

Helpful Hints

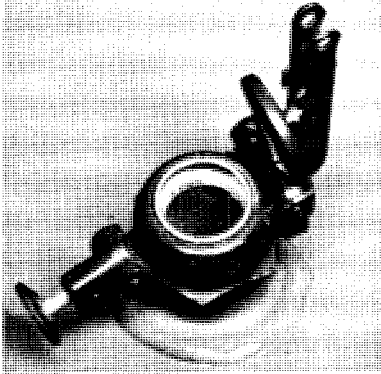

FUEL FILLER CAP

13298M

Before filling gas tank, make certain filler cap is in place and visually inspect screen for damage.

Smoking or any open flame is prohibited in fueling area.

Refuel only at designated areas.

Never operate truck with a leaking fuel system. Report condition to designated authority.

In addition to the normal Diesel engine stop control, the G.M. Diesel has an emergency stop that shuts off the air supply. If the emergency stop handle is pulled, the mechanism must be reset. This can be done by pushing down on the reset lever after the stop handle has been pushed in.

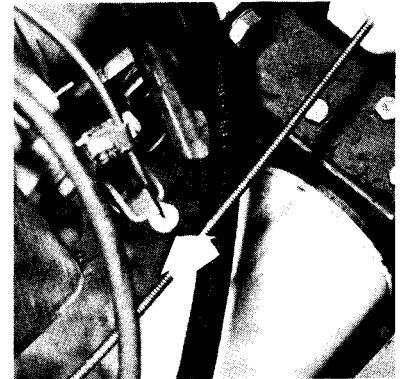

EMERGENCY STOP
RESET LEVER

12092

Helpful Hints



**QUICK-DISCONNECT
COUPLING**

13250M

To Exchange L.P. Gas Tanks —

1. Close container valve by turning to the right (clockwise).
2. Operate engine until it stops. All gas vapors between tank and carburetor should now be burned. Turn key switch off.
3. Disconnect fuel line at quick-disconnect coupling. Tools should not be required to connect or disconnect coupling.

4. Loosen container fasteners . . . swing and lift up container mounting cover . . . remove container.
5. Replace with recharged container by reversing above procedure. Make sure that tank locating hole is secured over the positioning pin in the tank cover.
6. Open tank valve slowly to ensure that automatic safety check valve does not cut off fuel supply. See Page 36.

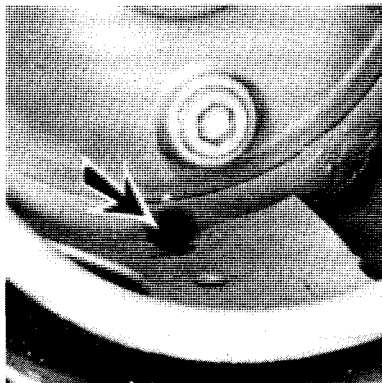

TANK POSITIONING-PIN

13251M

HELPFUL HINTS

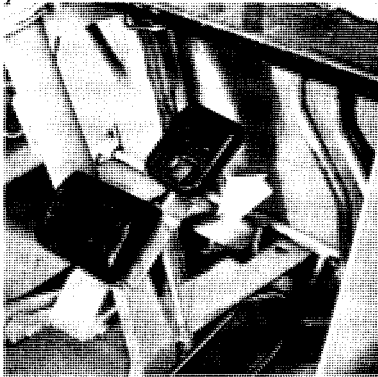

13302 M
13299 M

Pneumatic tire trucks with Hydracool transmission have an auxiliary accelerator pedal mounted on the brake pedal. Engine speed can be controlled by the toe of the right foot for fast lift and tilt while applying the foot brake.

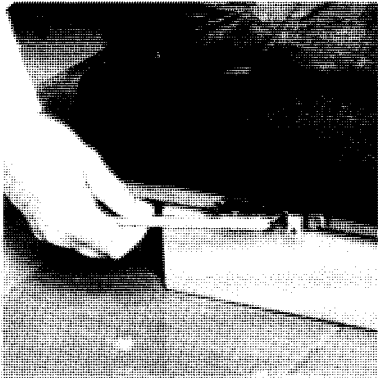

Seat adjustment is easily made by pulling out on the lever located next to the seat. The seat can be slid fore and aft to the most comfortable position.

Code: OI-335 Oct. 73

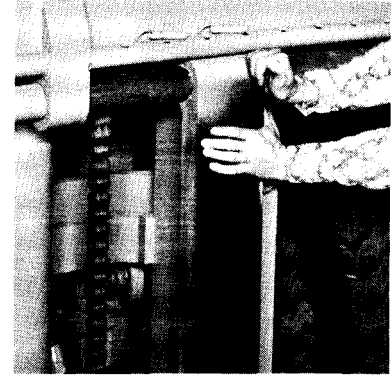

13301 M
13291 M

When adjusting fork spread, tilt upright forward. This reduces friction and makes sliding easier. Always make sure fork locking pins are secure.



The hood center section can be raised after pulling out on either knob located near the front corners. The side panels are not latched. Simply swing them up and back.

Helpful Hints

- **FUEL RECOMMENDATIONS**

Gasoline 85 Octane Minimum (Motor Method)
 L.P. Gas HD 5 Propane
 Diesel Fuel ASTM No. 1 or No. 2 (45 Cetane Minimum)

- **ENGINE CRANKCASE OIL**

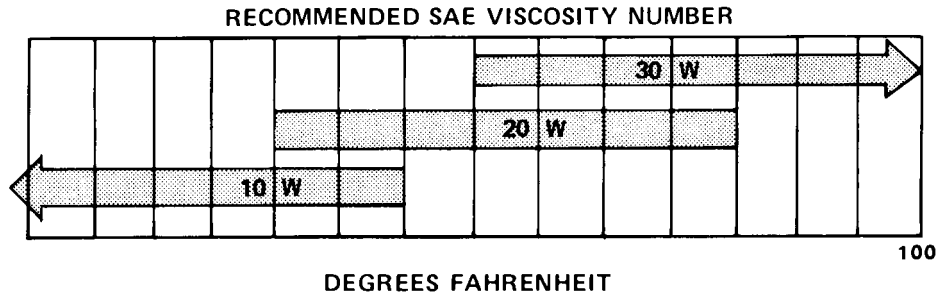

Check PM manual for oil specifications.

- **PNEUMATIC TIRE INFLATION PRESSURES (P.S.I.)**

	<u>Single Drive</u>	<u>Dual Drive</u>	<u>Steer</u>
Standard Tires	[724 kPa]	[724 kPa]	[724 kPa]
Wide Profile Tires (Where Available)	105 PSI NA	105 PSI NA	105 PSI NA

Wheel and Tire Maintenance

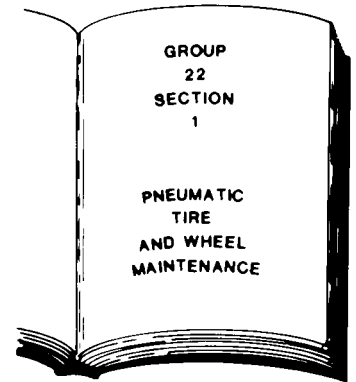
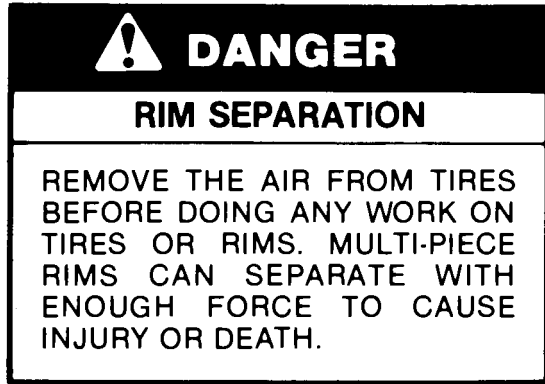

24309

Federal and State laws require persons to be fully trained and qualified before doing maintenance on wheels and tires. Injury or death can result from the explosive separation of rim components if service procedures are not done correctly.

1. Refer to the planned maintenance manual for complete wheel and tire servicing procedures.

Wheel and Tire Maintenance

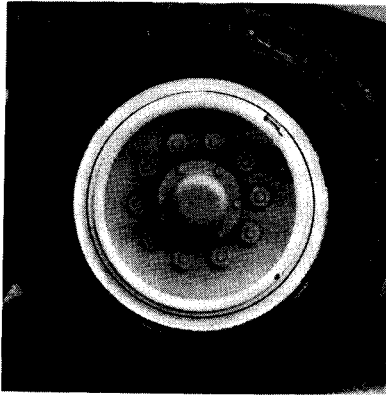

18924

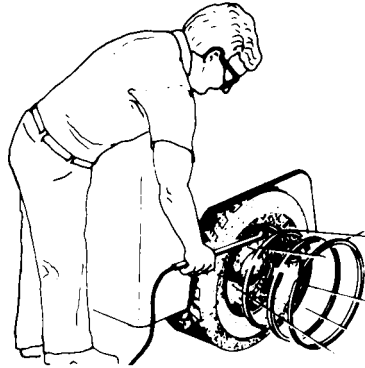

24307

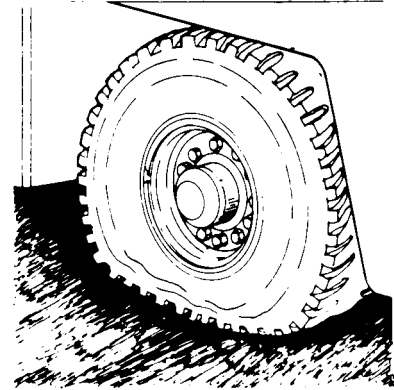

24308

2. Inspect wheels, tires and mounting parts for condition and security daily.

3. Do not stand in front of or in the trajectory path of wheels when checking or adding air pressure. Stand to the side and use a gauge with a long handle and a self attaching air chuck on the hose.

4. Do not put air into a tire which has gone flat or has less than 80 percent of recommended pressure. Check for cause of air loss and confirm that the wheel and tire are safe to use.

Wheel and Tire Maintenance

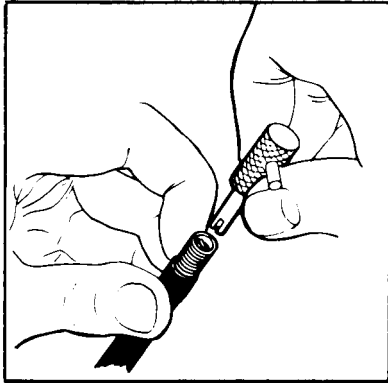

18631

5. Remove air from the tire before moving wheel clamping nuts (two piece wheels) or rim locking rings on multi-piece rims.

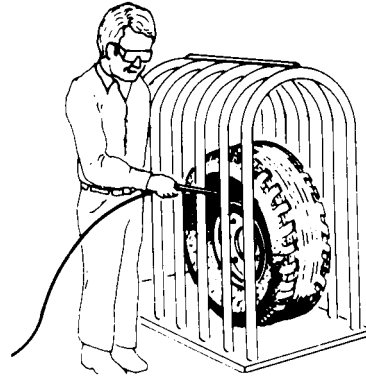

24306

6. Always use a safety cage to inflate tires after servicing. See Page 44 for tire pressures.

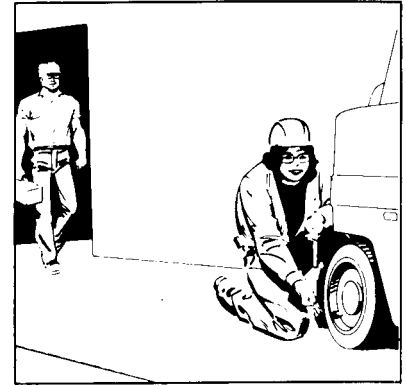

24964

7. Check tire pressure from a position facing the tread of the tire, not the side. Use a long handled gauge to keep your body away from the side.

If tires are low, do not add air. Check with a mechanic. The tire may need to be removed and repaired.

Truck Tip-Over

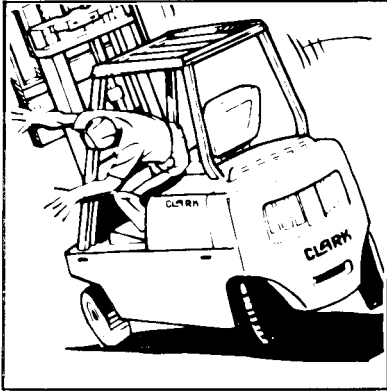

24976

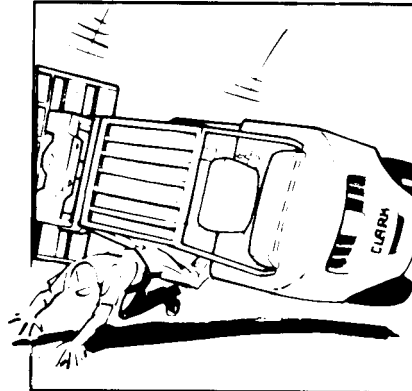

24977

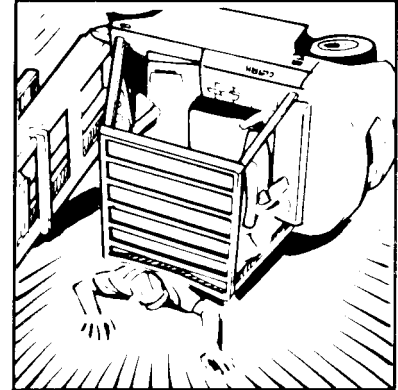

24978

This three-picture sequence shows what happens if an operator tries to jump from a truck during a tip-over.

If your truck starts to tip over, do not jump.

**Your chances for survival in a tip-over are better if you stay with the truck.
The following page shows the position to take in the event of a tip-over.**

Truck Tip-Over



24980

Make sure your seat belt is buckled at all times.

**STAY
IN
YOUR
SEAT**





24979

Take this position in the event of a tip-over.

Jump Starting

1. This truck has a 12-volt battery and a negative ground electrical system. Make sure that the other truck also has a 12-volt battery and negative ground system. If not sure of the voltage (or if the ground is different) do not try to jump start, as personal injury or damage to the electrical system can result.

 WARNING
SHORT CIRCUITS
REMOVE ALL JEWELRY. DO NOT PERMIT ANY METAL TOOLS TO MAKE CONTACT WITH THE POSITIVE BATTERY TERMINAL AND OTHER METAL ON THE TRUCK. MAKE SURE WHEN CONNECTING JUMPER CABLE CLAMPS TO THE POSITIVE TERMINALS OF THE BATTERIES THAT NEITHER CLAMP CONTACTS ANY OTHER METAL. INJURY CAN OCCUR FROM ELECTRICAL SHOCK OR EXPLOSION.

 WARNING
SULFURIC ACID
THE BATTERY CONTAINS CORROSIVE ACID WHICH CAN CAUSE INJURY. IF ACID CONTACTS YOUR EYES OR SKIN, FLUSH IMMEDIATELY WITH WATER AND GET MEDICAL ASSISTANCE.

 WARNING
EXPLOSIVE GASES
DO NOT SMOKE OR HAVE OPEN FLAMES OR SPARKS IN BATTERY CHARGING AREAS OR NEAR BATTERIES. AN EXPLOSION CAN RESULT AND CAUSE INJURY OR DEATH.

Jump Starting

2. Put the truck with the good (charged) battery so that the jumper cables will reach. **DO NOT PERMIT THE TRUCKS TO TOUCH AND CHECK TO SEE THAT THE TRUCKS DO NOT TOUCH.**
 3. Turn all accessories on both trucks to the "Off" position. Turn the ignition key to the "Off" position, apply the parking brake, and put the transmission of both trucks in the neutral position.
 4. If the discharged battery has filler caps, check the fluid level. (**DO NOT USE AN OPEN FLAME TO CHECK. DO NOT SMOKE.**) Add distilled water to the correct level if low and install the caps before jump starting. If the battery is a sealed type, do not try to jump start the truck, or charge it or test it if the center of the test indicator in the battery is bright or light colored. Instead, install a new battery.
5. Jumper cable connection instructions (Fig. 24871):
 - a. Connect the first jumper cable from the positive "+" (Red) terminal on one battery to the positive "+" (Red) terminal on the other battery. **NEVER connect "+" (Red) to "-" (Black), or "-" to "+".**

24871

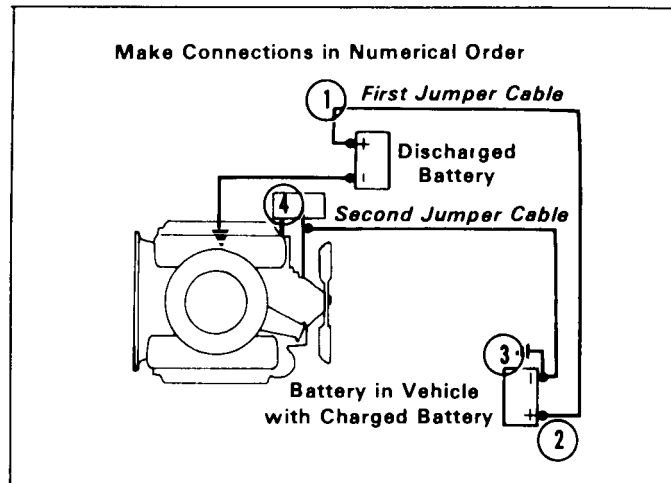

Jump Starting

5. (Continued)

- b. Connect one end of the second cable to the grounded negative “ - ” (Black) terminal of the good (charged) battery.
 - c. Connect the other end of the second jumper cable to a solid, stationary, metallic point on the engine of the truck with the discharged battery but at a point away from the battery. At least [450 mm] 18 inches from the battery if possible. Do not connect it to pulleys, fans, or other parts that move. Take care not to touch hot manifolds which can cause severe burns.
6. Start the engine on the truck with the good (charged) battery and run the engine at a moderate speed.

7. Start the engine of the truck that has the discharged battery.
8. Remove the jumper cables by reversing the above sequence exactly. Start by removing the last cable first; that is, remove the jumper cable from the truck with the discharged battery as the first step.

For Handy Reference

RECORD THE FOLLOWING INFORMATION PERTAINING TO YOUR TRUCK

Model No.

Serial No.

Attachments

Truck Weight W/Battery

Truck Rated Capacity

Gross Truck Weight (W/Battery and Rated Load)

Customer Truck Identification No.



Additional copies of this manual may be purchased from
YOUR AUTHORIZED CLARK DEALER

CLARK[®] Material Handling
Company

Lexington, KY 40507

Printed in USA