

# Operator's Instruction Manual

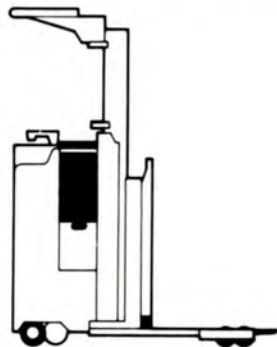

NS/NST/NSP 20 thru 40—RP/RPF 40 thru 60

**CLARK**



# **WARNING**

**FOR YOUR SAFETY AND THE  
SAFETY OF OTHERS**

**BEFORE YOU OPERATE THIS TRUCK!**

**READ ALL WARNINGS AND INSTRUCTIONS IN THE  
OPERATOR'S MANUAL AND ON THE TRUCK.**

**CHECK THE TRUCK FOR CORRECT OPERATION.**

**DO NOT OPERATE THIS TRUCK UNLESS YOU ARE  
TRAINED AND AUTHORIZED TO DO SO.**

# FOREWORD

Federal and state laws require that operators be completely trained in the safe operation of lift trucks.

Before you start operating this lift truck, make sure that you understand all driving procedures. It is important to operate your lift truck safely and efficiently.

This manual will help you learn how to operate your lift truck. This manual describes the controls, special features and the functions of each control.

This manual is not a training manual, it is a guide to help authorized operators safely operate a lift truck. Illustrations in this manual show the operator correct procedures for checking, starting, operating and stopping the lift truck.

Clark lift trucks are built to take hard work, but not abuse. They are built to be dependable but as with any lift truck, they are only as efficient as the operator and the persons responsible for maintaining them.

Do not make any repairs to this truck unless you have been trained in lift truck repair procedures and authorized by your employer.

MANUALES DE INSTRUCCION PARA OPERADORES IMPRIMIDOS EN ESPAÑOL SON OBTENIDOS DE SU DISTRIBUIDOR CLARK.

BETRIEBSANWEISUNGEN IN DEUTSCHER SPRACHE KOENNEN SIE BEI IHREM CLARK-HAENDLER ERHALTEN.

MANUELS DE L'OPERATEUR EN LANGUE FRANCAISE PEUVENT ETRE COMMANDES CHEZ VOTRE DISTRIBUTEUR CLARK.

# TABLE OF CONTENTS

Operator's Warning .....	Page i
Foreword .....	Page ii
Drive Safely .....	Page 1
Summary of Safe Operating Procedures .....	Pages 2-3
Safety .....	Pages 5 thru 15
Know Your Truck .....	Page 16
Major Components .....	Pages 16 thru 17
Controls — location .....	Pages 18 thru 21
Controls — function .....	Pages 21 thru 22
Capacity and Data Plate .....	Page 23
Truck Operating Features .....	Page 24
Operator's Daily Checklist .....	Page 26
Truck Operating Procedure .....	Page 31
Handy Reference Chart .....	Page 33

# **DRIVE SAFELY**

**BEFORE YOU OPERATE THIS INDUSTRIAL TRUCK, READ AND UNDERSTAND THE INSTRUCTIONS, SIGNS AND MESSAGES IN THIS MANUAL AND ON THE TRUCK.**

**INJURY OR DEATH TO YOU OR OTHER PERSONNEL WILL OCCUR IF YOU DO NOT FOLLOW THESE INSTRUCTIONS AND MESSAGES.**

**STAY ALERT!**

# SUMMARY OF SAFE OPERATING PROCEDURES

1. Do not operate this truck unless you have been trained and authorized to do so. Read all warnings and instructions in operator's manual and on this truck.

2. Do not operate this truck until you have checked its condition. Give special attention to Tires, Horn, Lights, Battery, Controller, and Lift Systems including forks, limit switches, brakes, steering mechanism, and guards.

3. Do not operate the truck with wet or greasy hands.

4. Do not handle loads which are higher than the load backrest unless load is secured so that no part of it could fall backward.

5. Do not handle unstable or loosely stacked loads. Use special care when handling long, high or wide loads to avoid losing the load, striking bystanders, or tipping the truck.

6. Do not overload truck. Check capacity plate for load weight information.

7. Lift trucks will tip over if not properly operated. Start, stop, travel, steer and brake

smoothly. Slow down for turns and on uneven or slippery surfaces that could cause truck to slide or overturn. Operate carefully when traveling without a load as the risk of overturn is greater.

8. Travel with load or lifting mechanism fully raised. Look in the direction of travel and operate the truck so that the load does not interfere with your view.

9. Operate carefully on ramps, travel slowly and do not angle or turn. Always operate on ramps with load end downhill.

10. Observe applicable traffic regulations. Yield right-of-way to pedestrians. Slow down and sound horn at cross aisles and wherever vision is obstructed.

11. Before lifting, be sure load is centered and forks are completely under load.

12. Do not put any part of your body under the forks or load.

13. Do not lift or travel with personnel on the forks.

14. Do not permit passengers to ride on the truck.

15. Never lift or transport personnel on the forks of a lift truck. Use a manlift specifically designed for this purpose.

16. Make sure your truck is the correct fire safety type, and approved, for the area in which you are working. The correct type designation for the truck is on the nameplate. If unsure of the classification of the area you wish to enter, ask your supervisor before entering.

17. Before driving over a dockboard or bridgeplate, make sure it is secure. Drive carefully and slowly, and do not exceed its rated capacity.

18. Do not run over any objects as truck stability could be adversely affected.

19. Only authorized and qualified persons should make repairs and adjustments to the truck.

20. Report all accidents involving personnel, building structures, and equipment to the correct authority.

21. Before getting off truck, neutralize travel control, fully lower lifting mechanism and set parking brake. When leaving truck unattended, also shut off power.

# **SUMMARY OF SAFE OPERATING PROCEDURES (Continued)**

## **ADDITIONAL RULES FOR OPERATORS OF MOTORIZED RIDER TRUCKS**

1. Foot protection (safety shoes) must be worn.
2. Keep one hand on the directional control and one hand on the hand support when operating while riding on platform.
3. Use caution when traveling with load end leading due to steering characteristics.
4. Use caution when turning. The load wheels tend to cut the corner.
5. Enter elevator, or other confined areas, with load end leading.
6. Position your feet firmly but do not allow your feet to extend beyond the edges of the platform.

## **ADDITIONAL RULES FOR OPERATORS of NARROW AISLE, REACH & STRADDLE TRUCKS**

1. Never travel, lift, or lower with the reach mechanism extended except to place or remove a load from storage.
2. Travel with load resting on the forks, not the outrigger legs.

3. Before operating the reach mechanism, make sure that the brake is applied.

4. Do not allow anyone to step over the reach or straddle legs or insert any part of the body into the reach mechanism.

5. The reach mechanism should not be used as a means of pushing or dragging loads into position.

6. Use caution when right angle stacking in aisles, particularly when backing up so as not to drive into or under rack beams.

7. Travel on inclines with load upgrade.

8. Do not operate on inclines when the load engaging means is elevated above [300 mm] 12 inches.

# Know Your Truck

NS 20/30/40

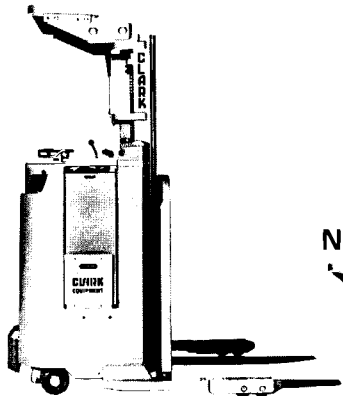

I-135

NST 20/25/30/40

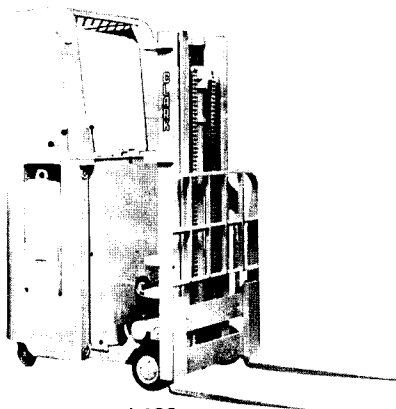

I-136

NSP 20/30/40

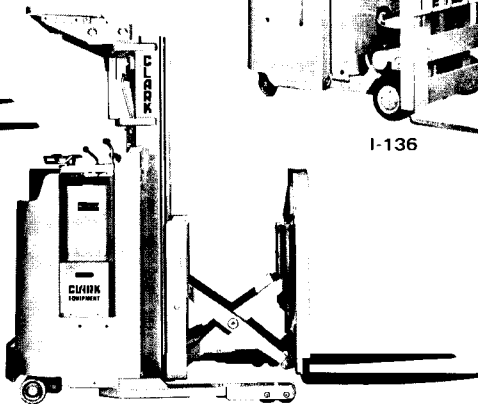

I-134

RP 40/60

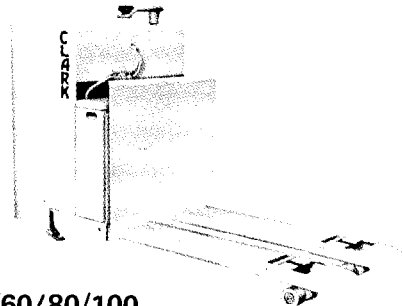

RPF 40/60/80/100

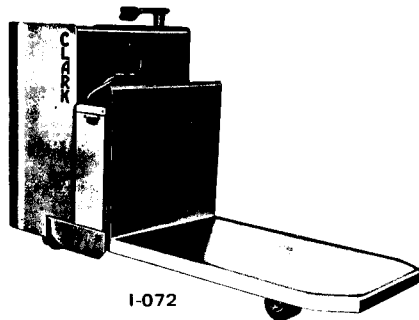

I-072

Clarklift Stand-Up, End Control Electric Models with rated capacities from 2000 lbs. thru 10,000 lbs. Five basic designs: NS-Narrow Aisle Straddle; NSP-Narrow Aisle with Pantograph; NST-Narrow Aisle Counterbalanced; RP-Rider Pallet; and RPF-Rider Platform.



# Safety

## BE A PRO!

Like any professional you must be thoroughly trained to operate a fork truck. Your ability to prevent accidents is an important part of your job.

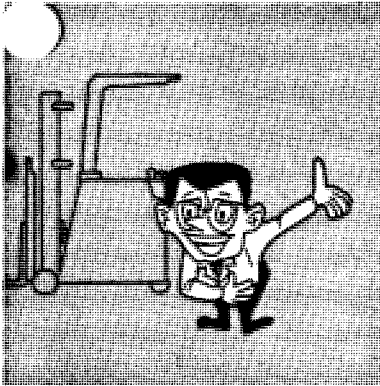

13198M

## KEEP YOUR FORKS DOWN!

One of the first things you must learn is never to operate your lift truck with the forks raised. You might hurt someone or damage valuable merchandise.

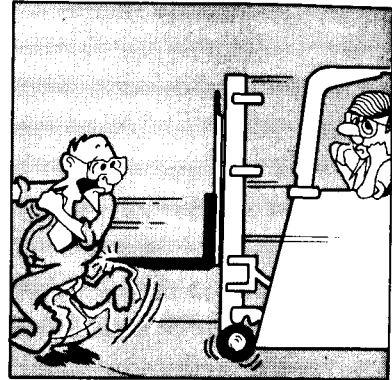

13209M

13207M

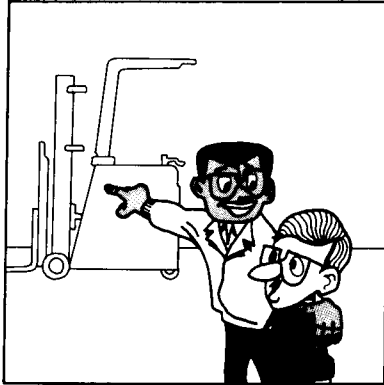

## LEARN YOUR JOB!

Practice turning, operating in narrow confines, stacking... Develop confidence in yourself and your equipment.

## OBEY THE LAW!

Observe regular traffic rules. Keep to the right; don't follow too close; keep your truck under control and avoid sharp turns.

13193M

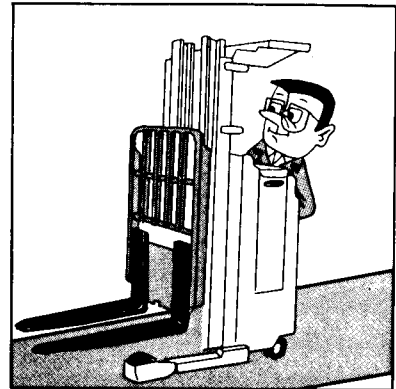

# Safety

## IF YOU CAN'T SEE, BACK UP!

If a load is too high or too wide to see around, operate the lift truck in reverse. But take it easy, and watch for people or obstructions on both sides. Always back down ramps with loaded truck.

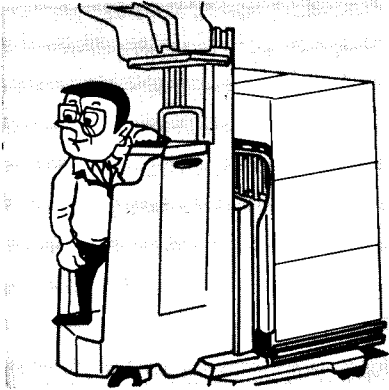

13202M

## LOOK UP!

Keep an eye overhead . . . you can damage sprinkler systems and pipes. This isn't the time or place for a shower.



13184M

13183M

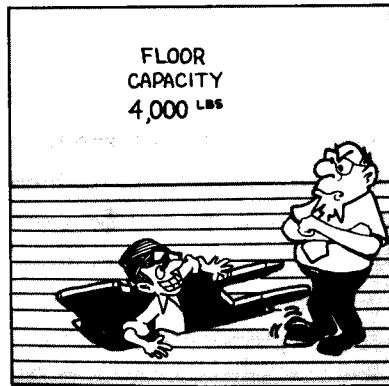

## CHECK FLOOR CAPACITY!

Be sure that elevators and floors in trucks and freight cars will support the combined weight of your truck and the load it is carrying.

## NO RIDERS . . . EVER!

The quick response of a lift truck will cause riders to fall off. Besides, they distract you and this could be dangerous. Hang the "No Riders" sign right away.



13204M

# Safety

## BE ALERT!

Obey all traffic signs and aisle markers. Slow down at aisle intersections and in crowded areas where people may step in front of you. Blow your horn at blind corners.



13087M

## PROTECT YOURSELF!

An overhead guard and a load backrest extension help protect you from falling objects and spilled loads. Use them.



13185M

13208M

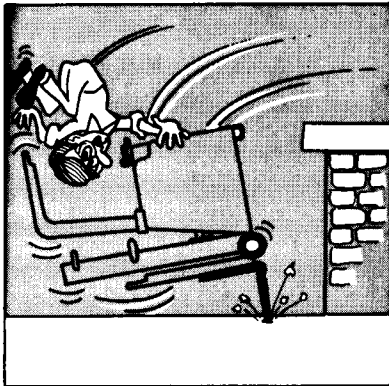

## STAY CLEAR OF THE EDGE!

Stay away from the edge of loading docks. One little slip and you may need a medic.

## SPACE FORKS TO FIT LOAD!

To maintain proper balance, load should be centered and forks should be near the outside edges. It's easy to make the move and may save a move to the hospital.

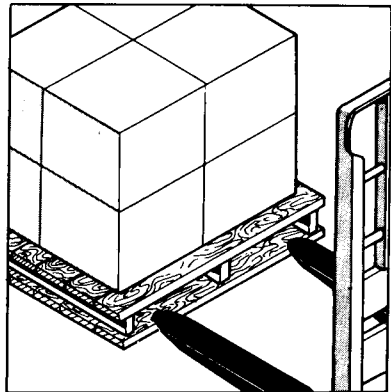

13203M

# Safety

## KEEP FEET INSIDE!

Never drive a lift truck with your legs, or any other part of your body, outside the running lines of the truck.

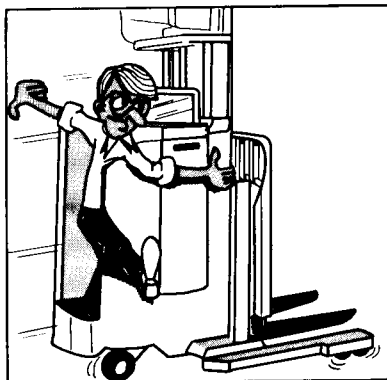

13201M

## NO SMOKING!

Never smoke or allow anyone to smoke in areas where batteries are being charged or in areas where fuel or other flammable fluids are used or stored.

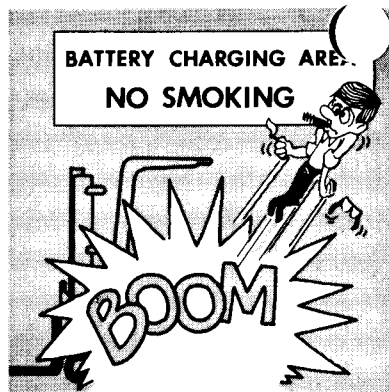

13180M

13197M

## KEEP CLEAR!

Never put your head, hands or feet into the upright for any reason. Don't allow anyone to stand, walk or sit under the forks.

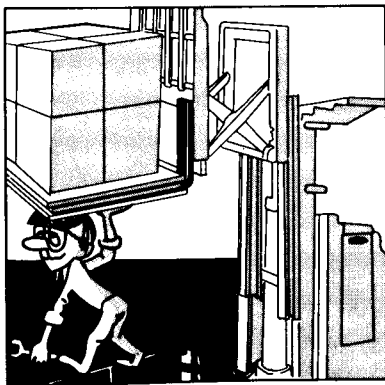

Do not move or raise personnel on the forks of a lift truck. Use a manlift specifically designed for this purpose.

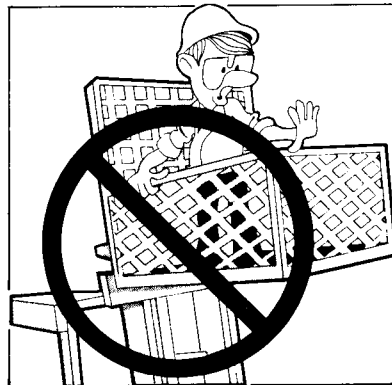

17631

# Safety

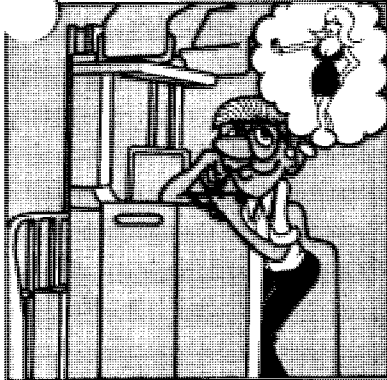

13189M

## DON'T DAYDREAM!

Keep your mind on your work. Learn to anticipate danger before it arises.

## CHECK YOUR PLATES!

Be sure bridge plates into trucks and freight cars are properly in place and secure. Also, trucks and railroad cars shall have their wheels blocked to prevent them from rolling.

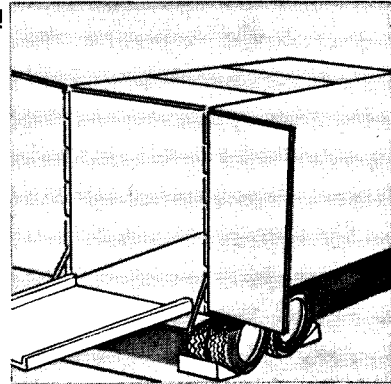

13146M

13186M

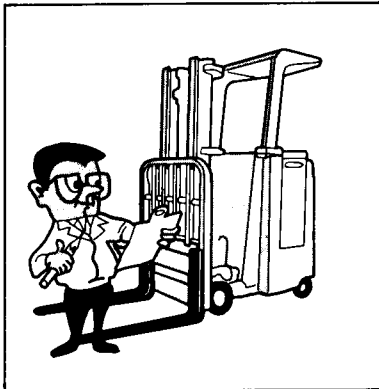

## KEEP IT CLEAN AND READY TO GO!

Check gauges, horn, upright and controls before you start. Take pride in operating a good, clean truck.

## REPORT ALL TROUBLES!

Report faulty truck performance to your supervisor. Don't try to make repairs yourself.

13212M

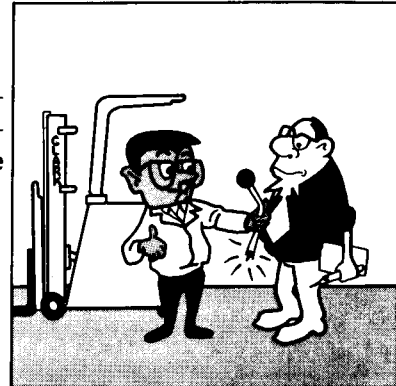

# Safety

## HELP PREVENT ACCIDENTS!

When you park your machine, lower the forks so they're flat on the ground. Develop the habit; it's very important.

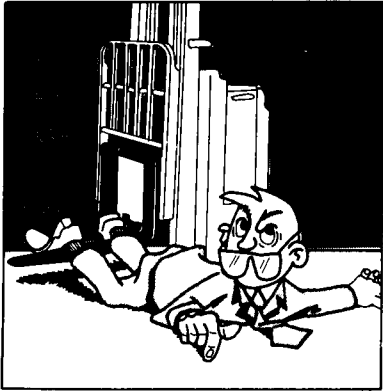

13187M

Use the plugging control to change direction of travel. Make sure it is adjusted correctly.

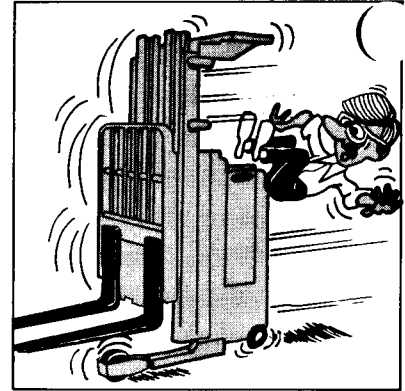

13182M

13210M

## EASE INTO THE LOAD!

Don't blast into stacked goods; like a fullback. In fact, don't even nudge them with forks or rear end of truck — you might damage the goods and yourself.



## DON'T LIFT UNSTABLE LOADS!

Obviously unstable loads should be repiled or banded. Once they are on the move, it's too late.

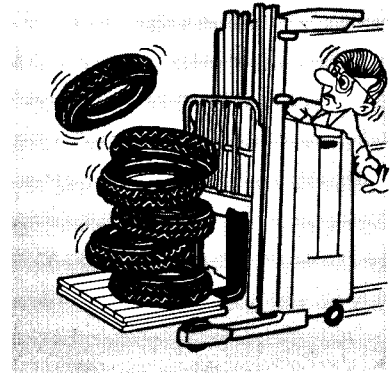

13211M

# Safety

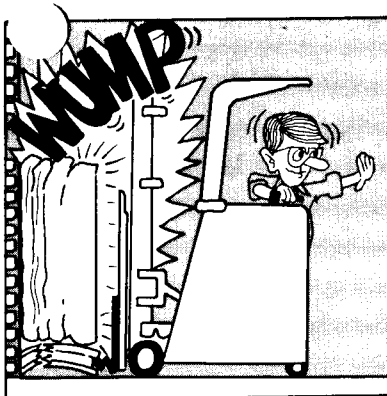

## KEEP EYES FRONT!

Always remember the most important rule of the road: Look where you're going. Wandering eyes mean a wandering truck, and that could be dangerous.

13194M

## WATCH YOUR ASSETS!

Be especially careful when traveling in reverse and turning. Maneuvering in tight quarters can be a pain.



13191M

13214M

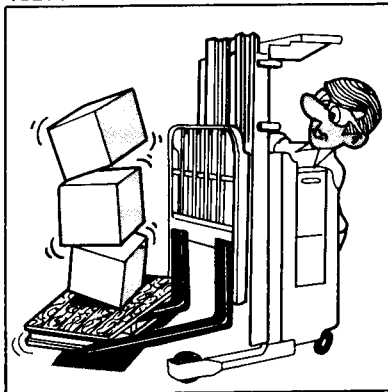

## PICK UP ALL THE LOAD!

Be sure your forks are all the way under the load. A spilled load means lost production time as well as material damage.

## TILT IT BACK!

Load should be tilted back until it rests securely for traveling. A load backrest extension gives added protection against spilling loads.

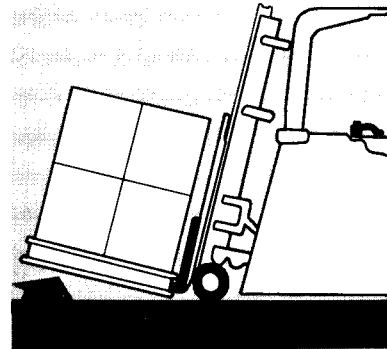

13215M

# Safety

## GET 'EM UP . . .

Raise loads just high enough to clear all floor obstructions. Ramps or inclines must be negotiated with load engaging means "uphill". Never attempt to turn on a ramp.

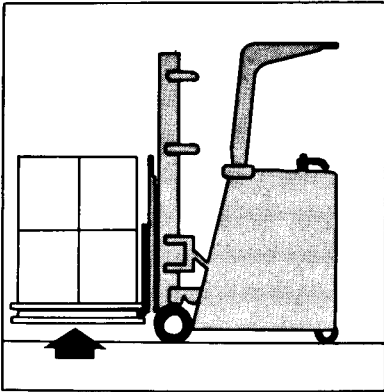

13159M

## DON'T DOUBLE UP!

Don't handle double tiered loads. They're unstable and difficult to control. Even an overhead guard can't fully protect an operator from heavy objects dropped from this height.

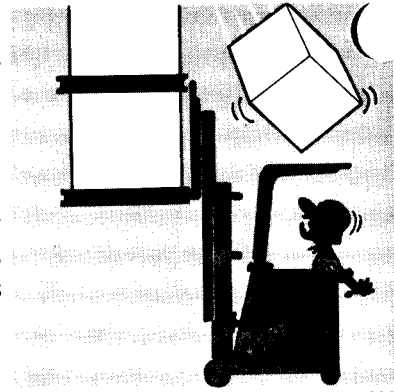

13206M

13200M

## BREAK 'EM DOWN!

Overloading is extremely dangerous. You don't have complete control of your truck and you're causing unnecessary wear. Don't add counterweight. Break down your load.

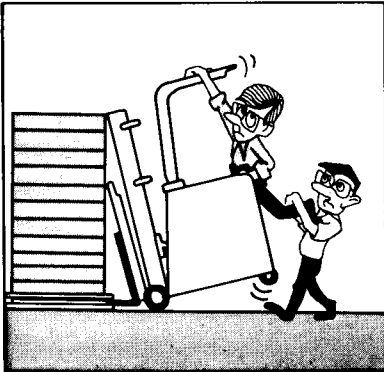

## KEEP OTHERS OFF YOUR TRUCK!

Keep unauthorized people away from the controls of your truck. They could spoil a good safety record . . . fast.

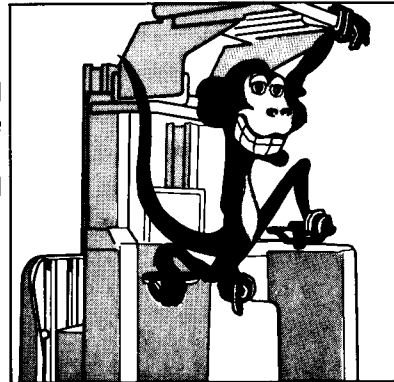

13192M



# Safety

## DON'T BE HALF SAFE!

Under normal traffic conditions, keep to the right. Maintain a safe distance, approximately three truck lengths, from the truck ahead and keep your truck under control at all times.

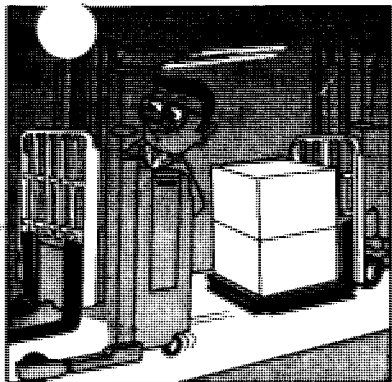

13185M

## NO RACING ZONE!

Do not pass another truck traveling in the same direction at intersections, blind spots, and other dangerous locations.

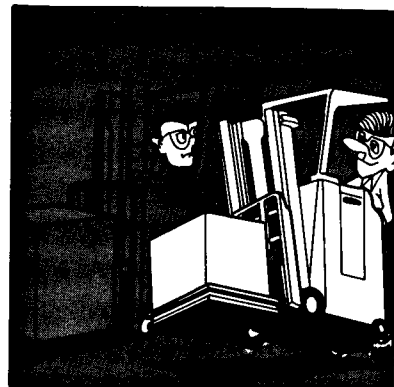

13188M

13190M

## SEE AND BE SEEN!

Slow down and sound horn at cross aisles and other locations where vision is obstructed. Yield the right-of-way to ambulances, fire trucks, and other emergency vehicles.

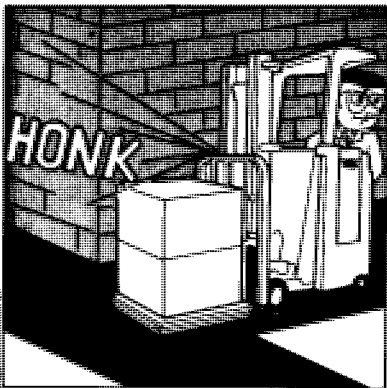

## SNUGGLE! DON'T JUGGLE!

Never operate pantograph while traveling with load. Even well stacked loads can be unstable under this condition. Do not drive with pantograph extended.

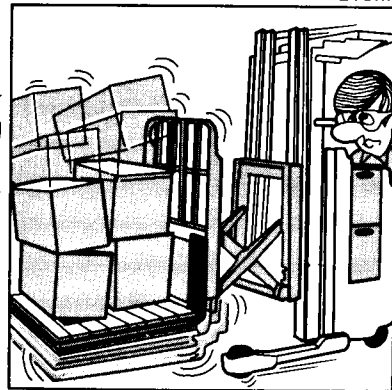

13213M

# Safety

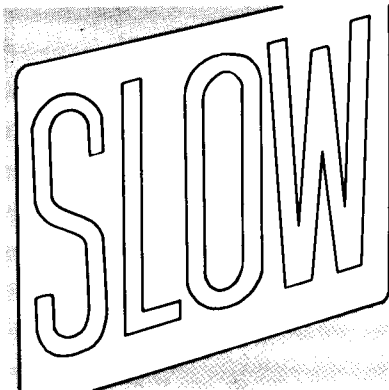

13103M

## SLOW – FOR SAFETY!

When operating surfaces are slippery due to rain, etc., slow down. Turning and high speeds can be dangerous.

13205M

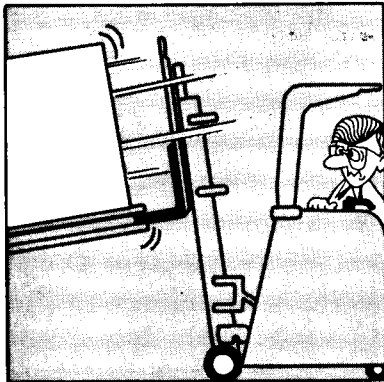

## TILT! YOU LOSE!

Use minimum forward and reverse tilt when stacking and unstacking loads. Never tilt forward unless load is over stack or at low lift height.

## READ IT FOR YOUR SAKE!

Prominently located on the truck is a list of basic safety rules. These rules are for your protection. Be familiar with them . . . for your sake.

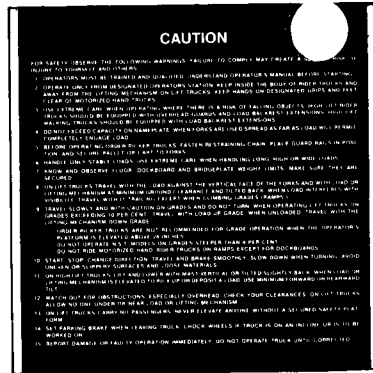

13110M

)

**Work Safely**

**Drive Safely**

**Be Careful**

# Know Your Truck

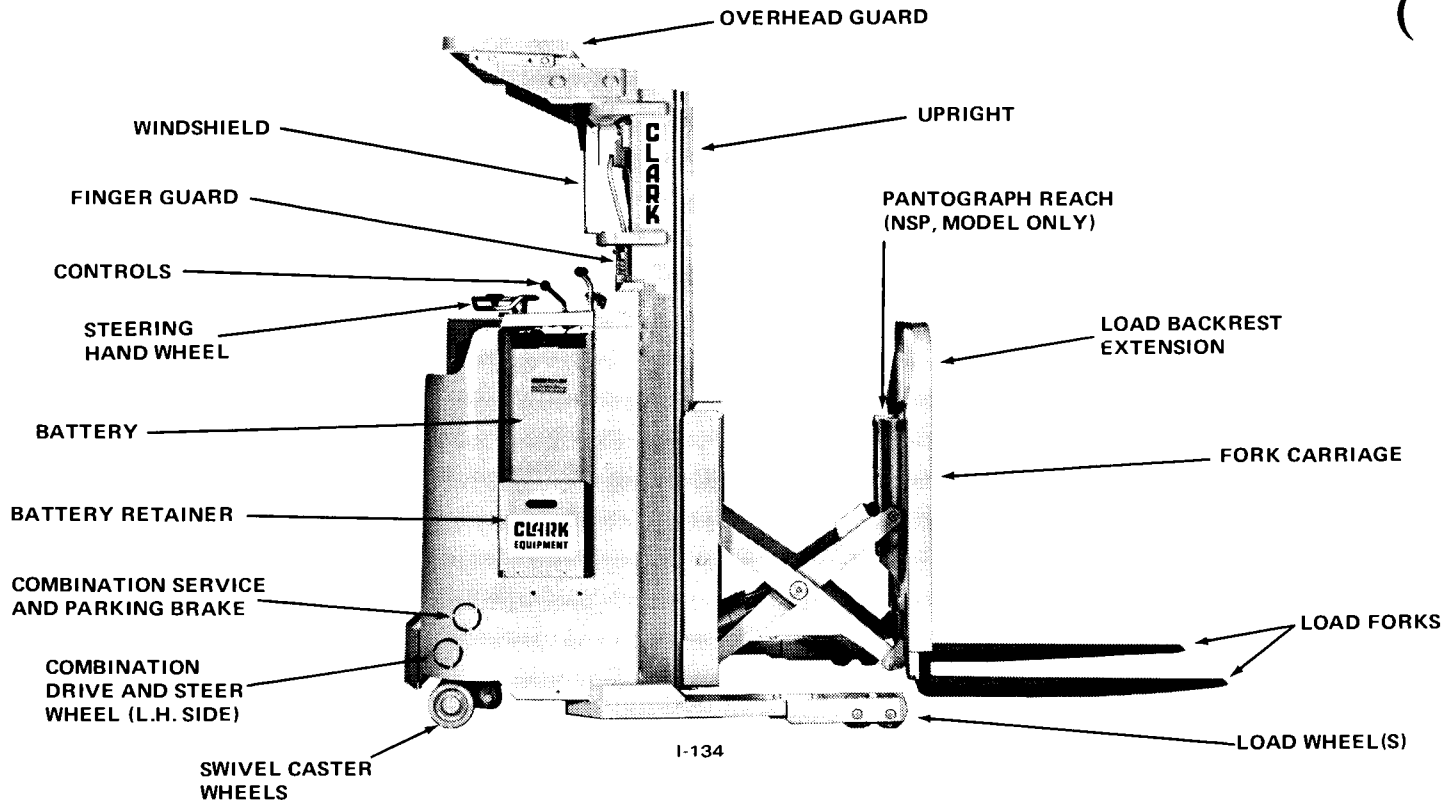

TYPICAL STAND-UP RIDER TRUCK

# Know Your Truck

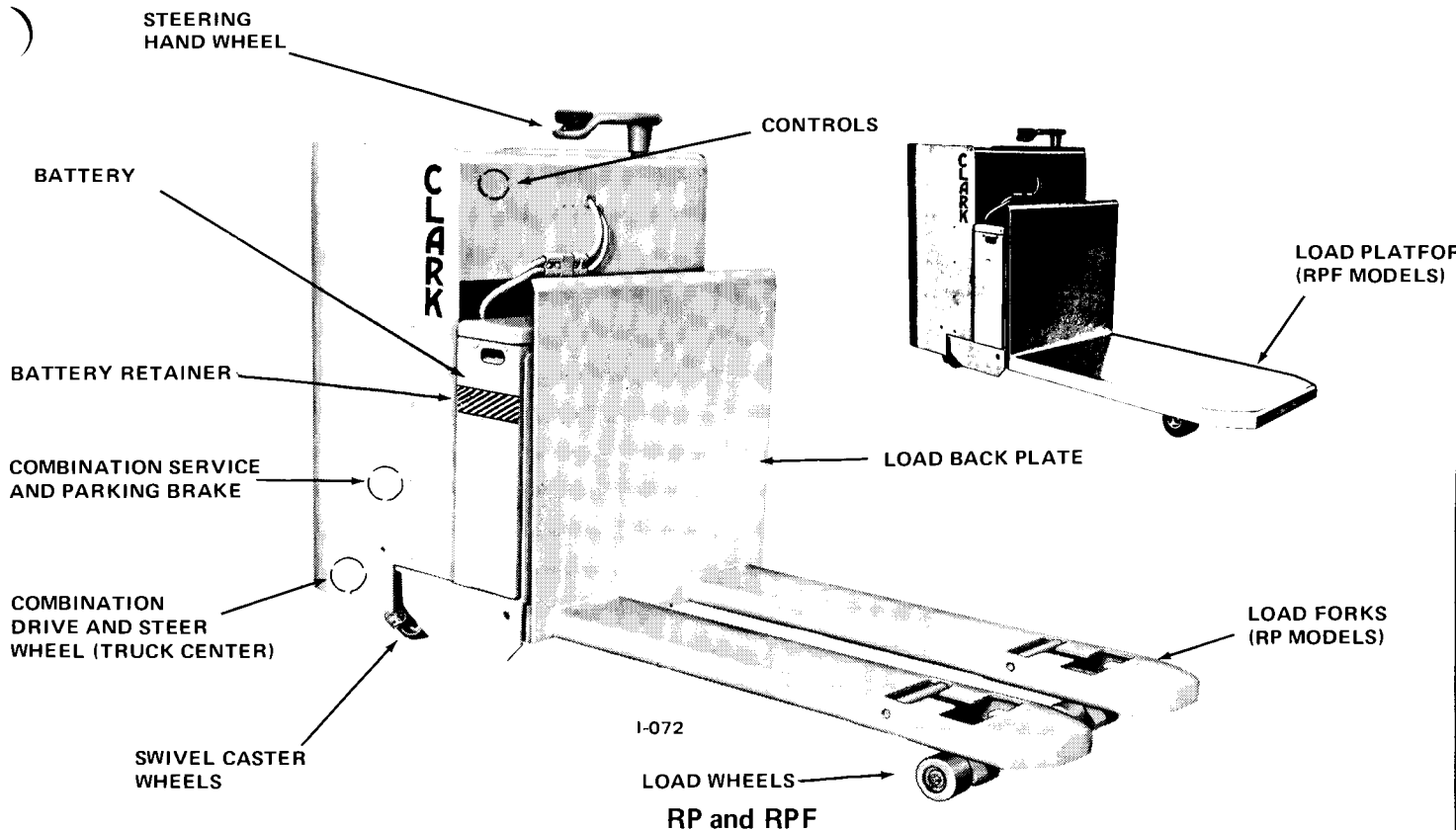

# Know Your Truck

All travel and hydraulic functions are controlled by levers conveniently located for operation by the operators right hand. Three basic arrangements are described in the following pages: one for the NS and NSP, one for the NST, and one for the RP and RPF.

One lever controls lift, lower and forward-reverse travel on the NS, NSP and NST models. Other lever(s) control hydraulic functions such as tilt and reach where provided.

On the RP and RPF models, travel is controlled by a thumb-operated, wing-type lever while hydraulic functions are controlled through push buttons.

The control levers are designed to regulate speed of operation as well as function. The further a lever is moved from the neutral position, the faster the selected function will be performed. For instance, moving the travel lever only slightly forward will cause the truck to move at a very slow speed in the forward direction. Additional movement will cause the truck to move faster until maximum speed is reached with the lever fully forward. Other functions will respond in a similar manner.

All levers will return to the neutral position when released.

Trucks equipped with hydraulic attachments or accessories will have either additional levers or control buttons in the handles of existing levers. The function of these controls should be checked with the proper authority.

Be completely familiar with all travel and hydraulic functions before operating the truck with a load. Learn to perform these functions in a smooth manner.

# Know Your Truck

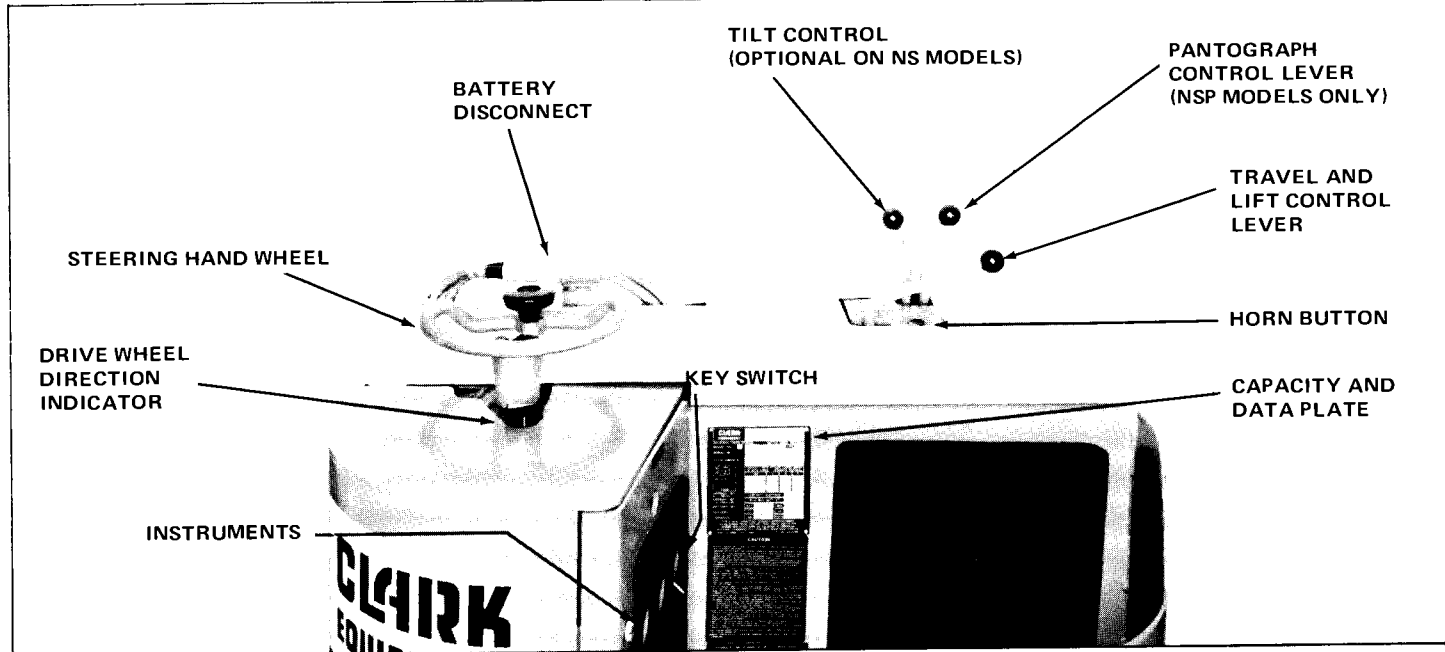

13255M

CONTROLS — NS and NSP

# Know Your Truck

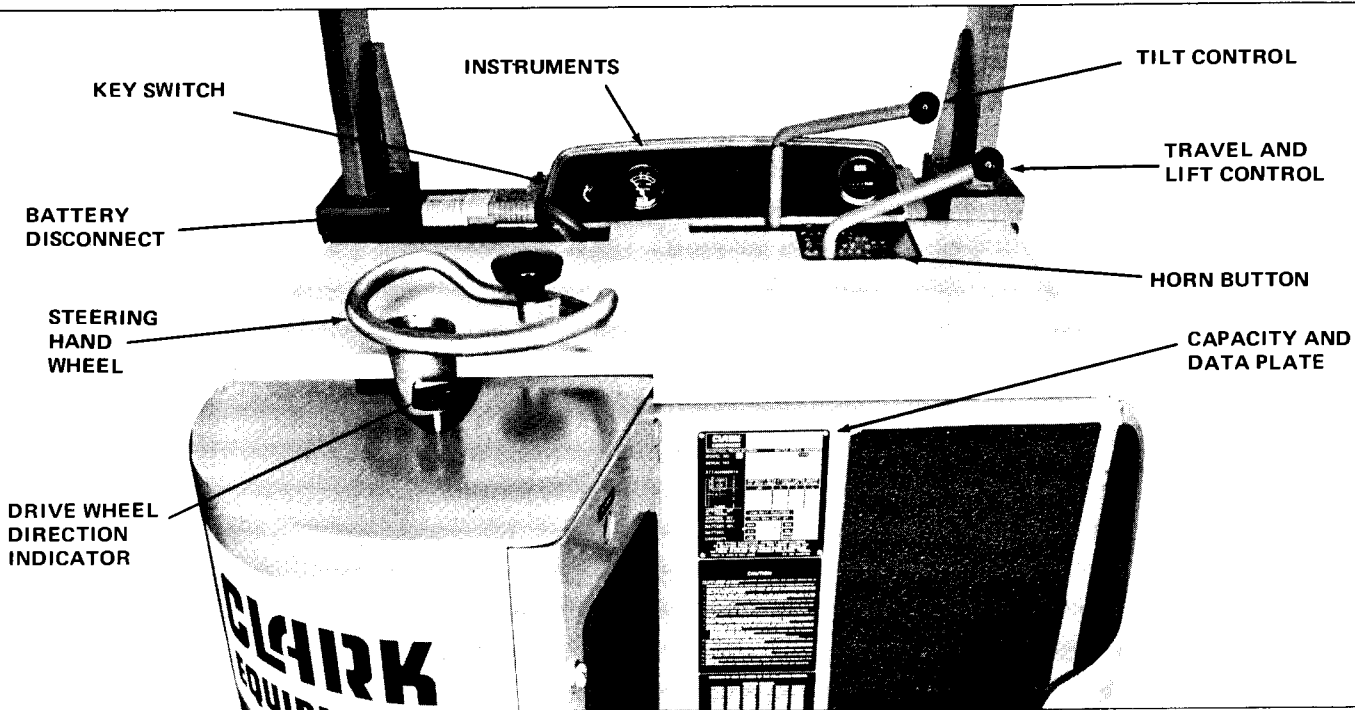

256M

CONTROLS - NST



# Know Your Truck

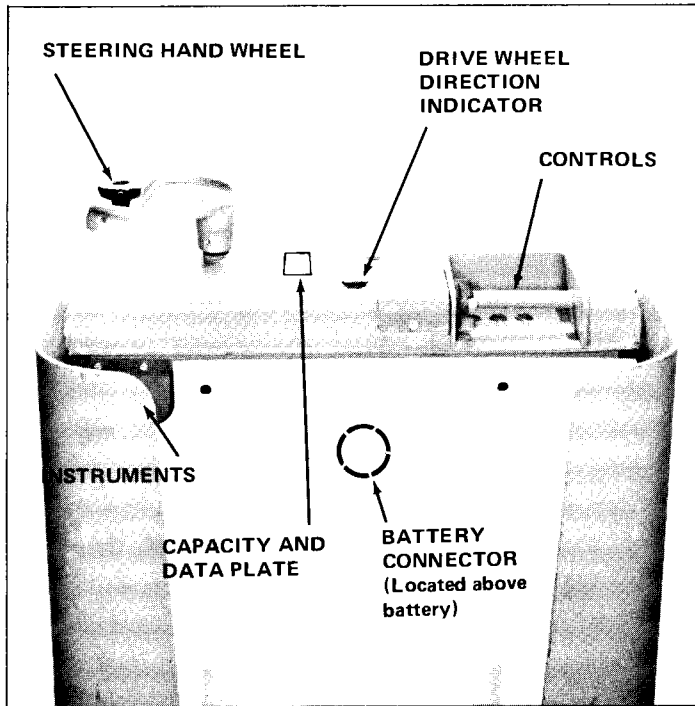

13257M

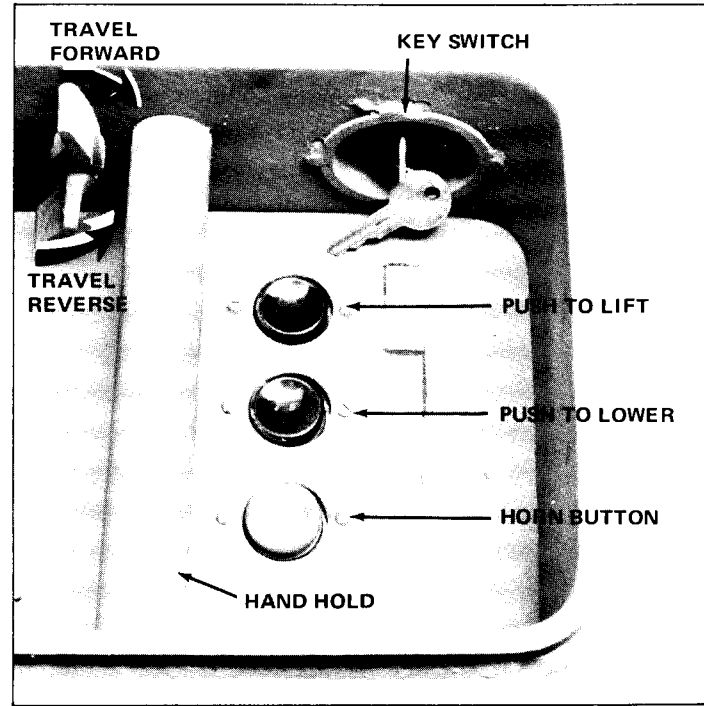

13259M

## CONTROLS – RP and RPF

# Know Your Truck

1326

13260M

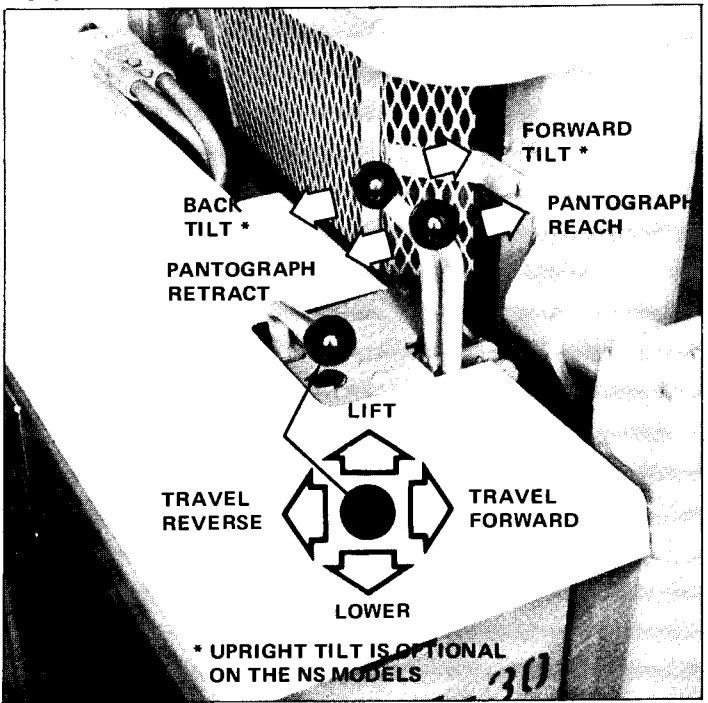

NS and NSP

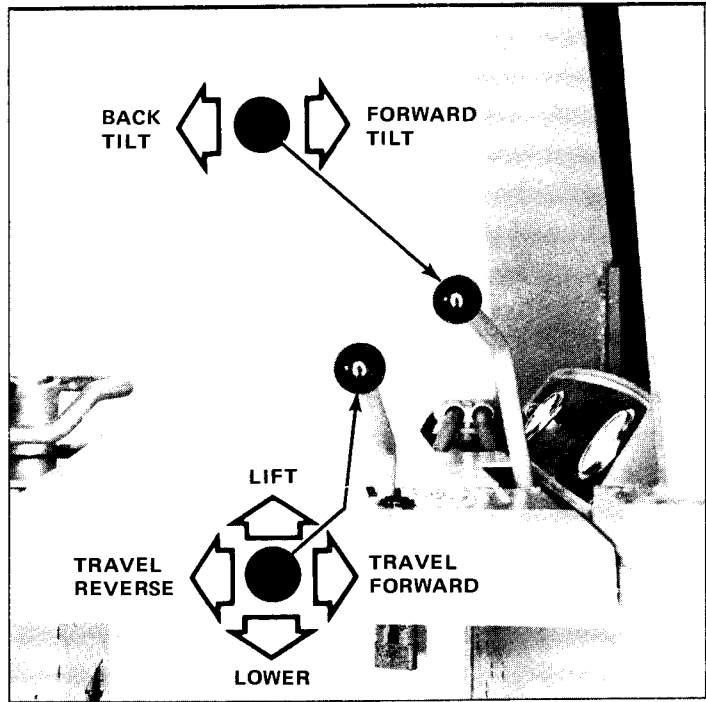

NST

## TRAVEL AND HYDRAULIC CONTROLS

# Know Your Truck

Know the location of your truck's . . .

- ① MODEL NUMBER
- ② TRUCK TYPE
- ③ SERIAL NUMBER
- ④ ATTACHMENT DESCRIPTION (If Any)
- ⑤ CAPACITY

Capacity, load center and lifting height data are stamped in these areas. Do not exceed the maximum specified.

IMPORTANT: If the truck is modified, capacity may be affected. The plate may be damaged or defaced. If either of these conditions exist, get a new plate from your Clark Distributor.

- ⑥ TRUCK WEIGHT WITH MAXIMUM BATTERY.

<b>CLARK EQUIPMENT</b>									
INDUSTRIAL TRUCK DIVISION BATTLE CREEK MICHIGAN									
MODEL NO. [ ]	[ 1 ] TYPE [ 2 ]								
SERIAL NO. [ 3 ]									
ATTACHMENTS [ 4 ]									
	CAPACITY WITH ATTACH. LISTED ABOVE OR WITH FORKS - UPRIGHTS VERTICAL								
	<table border="1"> <thead> <tr> <th>LBS</th> <th>A</th> <th>B</th> <th>C</th> </tr> </thead> <tbody> <tr> <td>[ 5 ]</td> <td></td> <td></td> <td></td> </tr> </tbody> </table>	LBS	A	B	C	[ 5 ]			
LBS	A	B	C						
[ 5 ]									
APPROX. WT. ALL TRUCKS	LESS BATT. - ELECTRICS [ 6 ]								
APPROX. WT. ELECTRICS ONLY	WITH MAX. BATT. WT.								
BATTERY WT.	<table border="1"> <tr> <td>MAX</td> <td>MIN</td> </tr> <tr> <td>AH</td> <td>NO.</td> </tr> <tr> <td>LBS</td> <td>VOLTS</td> </tr> </table>	MAX	MIN	AH	NO.	LBS	VOLTS		
MAX	MIN								
AH	NO.								
LBS	VOLTS								
CAPACITY									
FOR OTHER CAPACITIES - CONSULT MANUFACTURER AS RELEASED FROM FACTORY THIS TRUCK MEETS THE DESIGN SPECIFICATIONS ESTABLISHED IN AMERICAN NATIONAL STANDARD FOR POWERED INDUSTRIAL TRUCKS. PART II, ANSI B 56 1-1969 PT. NO. 2315709									

13217M

## DATA AND CAPACITY PLATE

# Know Your Truck

Be familiar with the locations and functions of all instruments and controls. Check frequently to ensure they are operating properly. Report any malfunction to the designated authority.

13226M

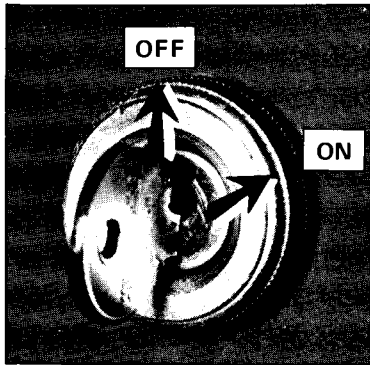

## KEY SWITCH

A two-position key switch is standard. The switch must be in the "on" position in order to perform any travel or hydraulic functions except lowering.

## BATTERY CHARGE INDICATOR

The battery charge indicator is the "fuel gauge" for electric trucks. If the needle falls into the red area while operating the truck, a low (or nearly empty) battery is indicated. The battery should then be replaced or recharged.

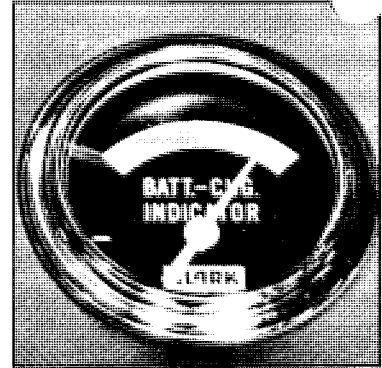

13179M

## HR METER

The hour meter registers total time electrical components, such as pump and drive motors, are operated. The hours recorded are used for planned maintenance and should be checked at the beginning and end of each shift.

13225M



PLATE 7162 C073-1

Code OI-327 Aug 73

# Know Your Truck

## DRIVE WHEEL DIRECTION INDICATOR

The travel direction indicator arrow points in the direction the drive wheel will go with the travel lever in the forward position. In reverse, travel will be toward the base of the arrow.

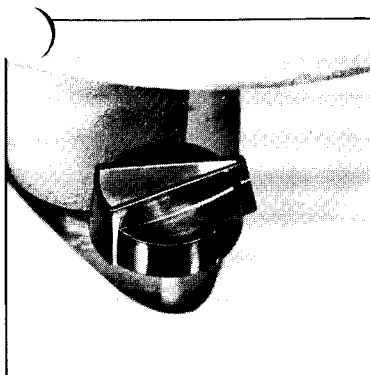

13262M

13263M

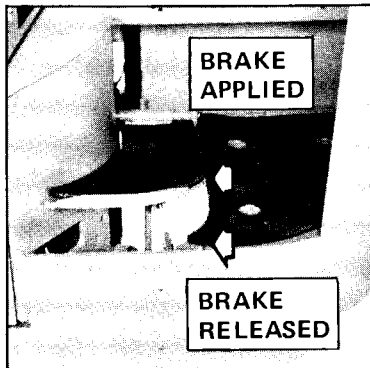

## BRAKE PEDAL

The brake pedal serves two functions: Parking and service. To travel, the pedal must be fully depressed. Slowly raising the left foot will gradually apply the brakes. In the up position, the brakes are fully applied.

## STEERING HAND WHEEL

The hand steering wheel is directional in operation. That is; when rotated clockwise, the truck will turn to the right when traveling forward and to the left when rotated counter-clockwise.

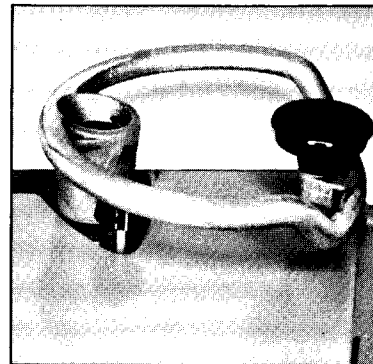

13264M

13284M

## BATTERY CONNECTOR

The battery connectors are located just ahead of the steer wheel, in the event of electrical malfunction or when leaving the truck unattended, the battery should be disconnected.

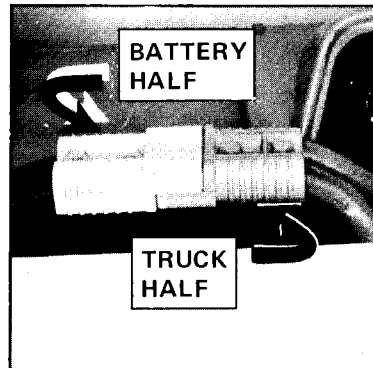

# Operator's Daily Checklist

One of your most important functions in making certain your truck is in safe and efficient operating condition is to make a quick and easy check at the beginning of your shift.

This should be viewed not only as a maintenance function, but also as a necessary step in doing everything possible to improve safety.

<input checked="" type="checkbox"/> Boxes Accordingly	<input type="checkbox"/> OK	<input type="checkbox"/> Needs Attention or Repair
---	-----------------------------	--

Visual Checks:	Operational Checks:				
<input type="checkbox"/>	<input type="checkbox"/>	Obvious damage and leaks	<input type="checkbox"/>	<input type="checkbox"/>	Horn
<input type="checkbox"/>	<input type="checkbox"/>	Tire condition	<input type="checkbox"/>	<input type="checkbox"/>	Steering
<input type="checkbox"/>	<input type="checkbox"/>	Battery plug connection <b>Note: Be sure the battery plug connection is tight.</b>	<input type="checkbox"/>	<input type="checkbox"/>	Service brakes
<input type="checkbox"/>	<input type="checkbox"/>	Head and tail lights	<input type="checkbox"/>	<input type="checkbox"/>	Battery Load Test <b>Note: Watch battery indicator while holding tilt lever on full back tilt. If needle falls to red area, battery doesn't have sufficient charge to operate truck properly.</b>
<input type="checkbox"/>	<input type="checkbox"/>	Warning lights	<input type="checkbox"/>	<input type="checkbox"/>	Parking brake
<input type="checkbox"/>	<input type="checkbox"/>	Hour meter	<input type="checkbox"/>	<input type="checkbox"/>	
<input type="checkbox"/>	<input type="checkbox"/>	Other gauges and instruments	<input type="checkbox"/>	<input type="checkbox"/>	Seat brake
<input type="checkbox"/>	<input type="checkbox"/>	Battery Discharge indicator <b>Note: Key on, needle should indicate in green area.</b>	<input type="checkbox"/>	<input type="checkbox"/>	Hydraulic controls

# Operator's Daily Checklist

The Daily Checklist . . . available from your Clark dealer . . . should be used to check out the truck. Then make certain the report is given to your maintenance department or the proper authority.

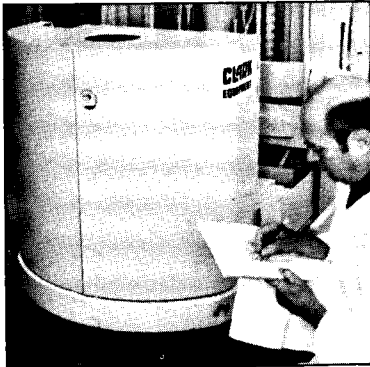

13109M

1. A visual check should be made for obvious damage and leaks. Either is a potential hazard to other employees as well as yourself.
2. The battery connector contacts should be clean and bright . . . without excessive pitting. If the connector becomes unusually warm or hot, report the condition to the proper authority.
3. Check all running and warning lights to ensure they are operating properly. Clean them as required.
4. Note hour meter reading on checklist. Be sure it is running.
5. The battery discharge indicator should register in the green area at all times when the key switch is on. If it registers in the red zone at any time during operation, recharge battery or replace with charged battery. On models equipped with a tilting upright, battery condition can be checked by tilting upright and holding control lever in "tilt" position for several seconds. Arrow should not fall into red zone.

# Operator's Daily Checklist

13265M

6. Make a steering performance check . . . rotate steering hand wheel back and forth. Excessive travel or looseness should be reported to the designated authority.
7. Make sure horn is working properly.
8. Check combination parking-service brake. Step on pedal with left foot to release brake. Accelerate a short distance and then slowly raise left foot. Brakes should bring truck to a controlled stop. When fully applied (pedal released), the brake should hold the truck with a capacity load on a 15% grade (1.5 feet rise in 10 feet) or the maximum grade negotiated, whichever is less.

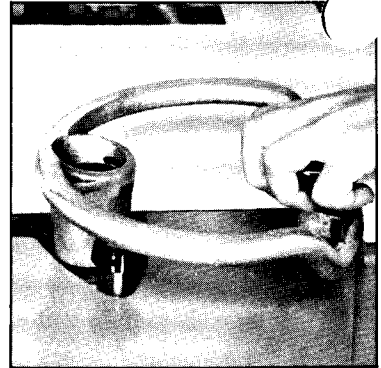

**CHECK STEERING**

## **PARKING-SERVICE BRAKE**

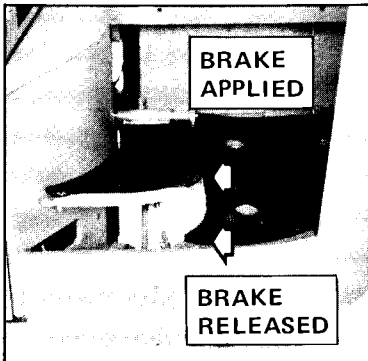

13263M

9. With brake pedal released and key switch on, move travel lever to forward or reverse position. The battery discharge indicator needle should not move since power to the drive motor should be cut-off when the brake pedal is in the raised position. If movement of the truck or indicator needle is noticed, report to designated authority.



# Operator's Daily Checklist

10. Check hydraulic functions with key switch in "on" position and a charged battery connected.

All movements of upright, carriage and pantograph should be smooth . . . without binding. Hydraulic control operations are described on pages 21 & 22.

13252M

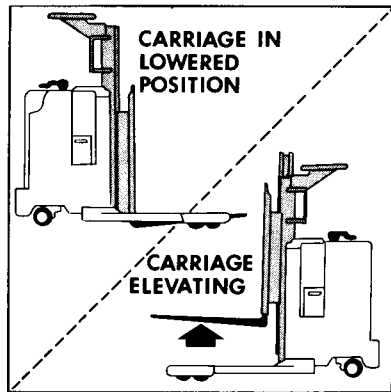

Raise carriage to maximum height. If carriage will not reach upper limit, a low hydraulic fluid level is indicated.

13253M

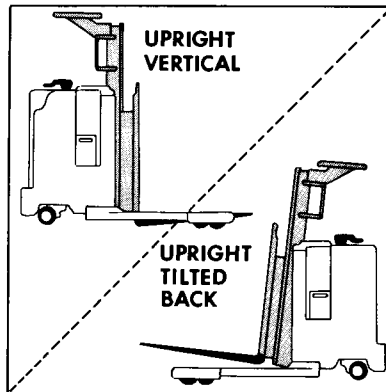

Tilt upright fully forward and rearward if truck is so equipped.

13254M

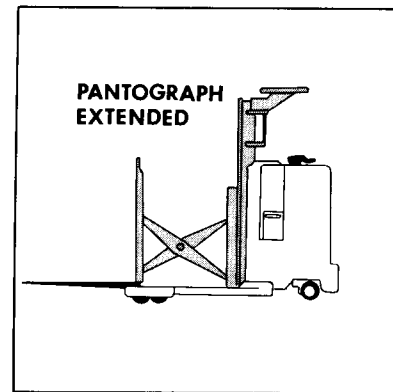

Extend (reach) and retract the pantograph if truck is so equipped. Fork carriage must travel evenly without cocking. Never travel with the pantograph in extended position.

Report any unusual operating conditions or noises to the proper authority.

# Operator's Daily Checklist

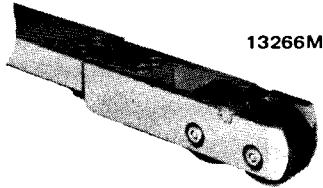

11. Tire condition is important for the safe operation of any vehicle. Remove all foreign material lodged in tire.

Remove any string, wire, etc., that may have become wrapped around the load wheel and caster wheel axle. Be sure that all wheels turn freely. Wheels must not scrub when truck is moving.

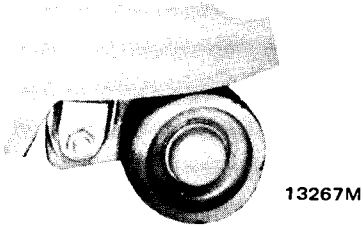

12. The caster wheel must swivel freely. Maneuver truck while watching caster to be sure it is functioning properly. Carefully check to be certain there are no obstructions in the area.
13. Battery retainers must be securely in place. Stop bolts must be adjusted so that battery cannot roll from side to side while truck is being operated.

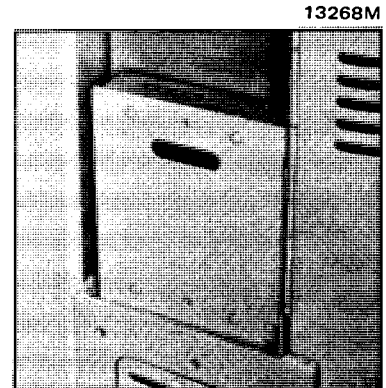

**BATTERY RETAINER**

Code OI-327 Aug 73

## Operating Procedure

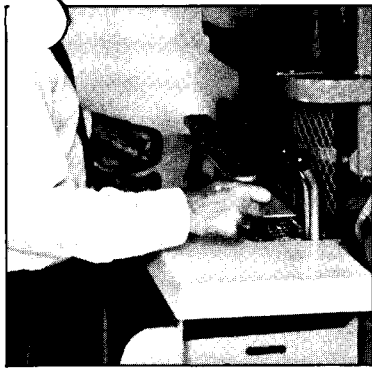

1. Stand on truck without depressing brake pedal and turn key switch to "on" position. Place right hand on lift-travel lever and left hand on steering hand wheel.

13269M

13270M

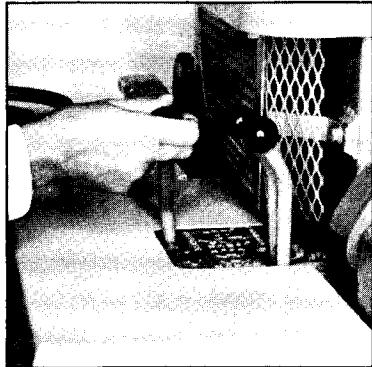

3. Lift up on travel-lift lever to raise forks to a travel position. About 4" to 6" off the floor.

2. Turn steering hand wheel until direction indicator points in the desired direction of forward travel or opposite the desired path of reverse travel. Be sure travel route is free of obstacles.

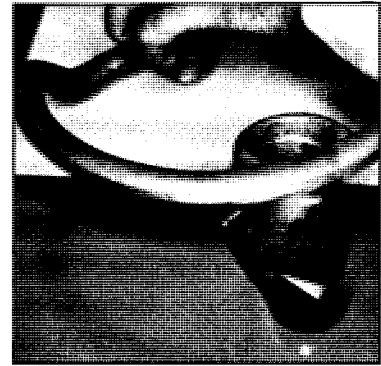

13271M

13272M

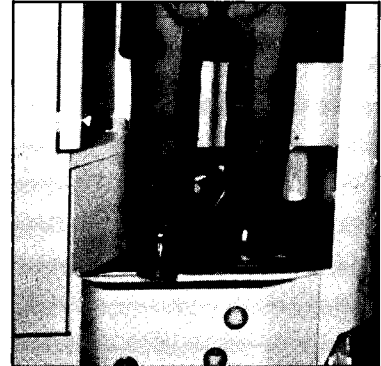

4. Depress brake pedal. This will release the brake and actuate a switch making power available to the drive motor. Move the travel-lift lever in the desired direction of travel.

# Operating Procedure

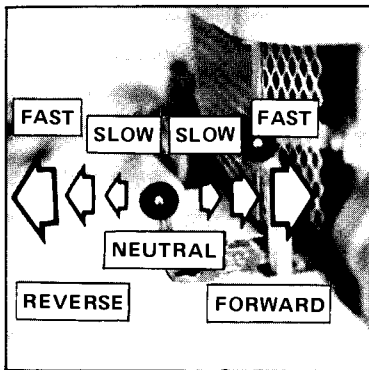

13273M

13275M

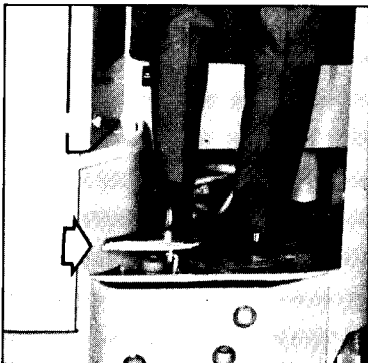

5. Remember! The farther the travel control lever is moved, the faster the truck will go until maximum speed is reached with the lever fully forward or back. Hydraulic functions react similarly.

7. To stop the truck, allow the brake pedal to slowly return to the "up" position. The truck will come to a smooth, controlled stop. The brakes are fully applied when the pedal is fully raised.

6. Perform lift, tilt and reach operations as required. Be alert for overhead obstructions. Especially when lifting and traveling with the forks raised.

8. To park, lower the forks to the floor and allow all controls to return to neutral. Turn key switch to "off" position and remove key. If truck is to be left for an extended period of time, disconnect battery.



13274M

13276M





(

## For Handy Reference

RECORD THE FOLLOWING INFORMATION PERTAINING TO YOUR TRUCK

Model No. ....

Serial No. ....

Attachments .....

Truck Weight W/Battery .....

Truck Rated Capacity .....

Gross Truck Weight (W/Battery and Rated Load) .....

Customer Truck Identification No. ....



Additional copies of this manual may be purchased from  
YOUR AUTHORIZED CLARK DEALER

---

---

**CLARK** Industrial Truck  
Division

Asheville, NC 28776  
Battle Creek, MI 49016  
Georgetown, KY 40324  
St. Thomas, Ontario, Canada N5P 1H2  
2.5C CGAC JUNE 84 Printed in U.S.A.