

---

# Operator's Instruction Manual

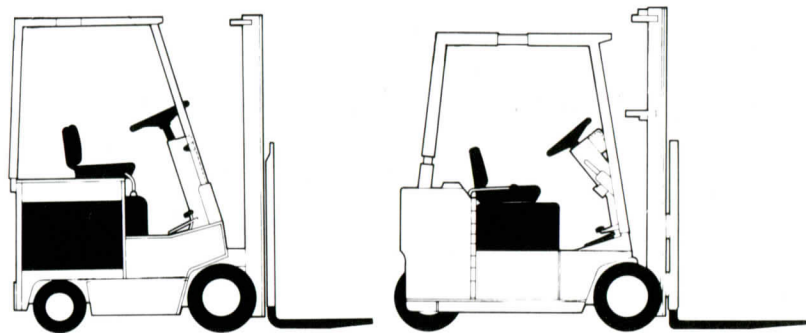

EC300 20 thru 30/TW 20 thru 40

---

# CLARK

Book No. 2385898  
OI-326, 1st REV.



## **WARNING**

- **FOR YOUR SAFETY AND THE SAFETY OF OTHERS.**
- **BEFORE YOU OPERATE THIS TRUCK!**
- **READ ALL WARNINGS AND INSTRUCTIONS IN THE OPERATOR'S MANUAL AND ON THE TRUCK.**
- **CHECK THE TRUCK FOR CORRECT OPERATION.**
- **DO NOT OPERATE THIS TRUCK UNLESS YOU ARE TRAINED AND AUTHORIZED TO DO SO.**

The following warnings are provided pursuant to California Health & Safety Code Sections 25249.5 et. seq:

### **IMPORTANT**

**Do not expose this manual to hot water or steam.**



## **WARNING**

### **California Proposition 65**

This product contains and emits chemicals known to the State of California to cause cancer, birth defects and other reproductive harm.

## FOREWORD

Federal and state laws require that operators be completely trained in the safe operation of lift trucks.

Before you start operating this lift truck, make sure that you understand all driving procedures. It is important to operate your lift truck safely and efficiently.

This manual will help you learn how to operate your lift truck. This manual describes the controls, special features and the functions of each control.

This manual is not a training manual, it is a guide to help authorized operators safely operate a lift truck. Illustrations in this manual show the operator correct procedures for checking, starting, operating and stopping the lift truck.

Clark lift trucks are built to take hard work, but not abuse. They are built to be dependable but as with any lift truck, they are only as efficient as the operator and the persons responsible for maintaining them.

Do not make any repairs to this lift truck unless you have been trained in lift truck repair procedures and authorized by your employer.

**MANUALES DE INSTRUCCIÓN PARA OPERADORES IMPRIMIDOS EN ESPAÑOL SON OBTENIDOS DE SU DISTRIBUIDOR CLARK.**

**BETRIEBSANWEISUNGEN IN DEUTSCHER SPRACHE KOENNEH SIE BEI IHREM CLARK-HAENDLER ERHALTEN.**

**MANUELS DE L'OPERATEUR EN LANGUE FRANCAISE PEUVENT ETRE COMMANDES CHEZ VOTRE DISTRIBUTEUR CLARK.**

## TABLE OF CONTENTS

Operator's Warning .....	Page i
Foreword .....	Page ii
Drive Safely .....	Page iv
Summary of Safe Operating Procedures .....	Page 1
Portraits .....	Page 2
Safety .....	Pages 3 thru 12
Operator's Compartment .....	Page 13
Before Operation Checks .....	Pages 14 thru 20
Operation .....	Pages 21 thru 25
Parking Instructions .....	Pages 26 and 27
Wheel and Tire Maintenance Safety Messages .....	Pages 28, 29, 30
Handy Reference .....	Page 31



# **DRIVE SAFELY**

**BEFORE YOU OPERATE THIS LIFT TRUCK, READ AND UNDERSTAND THE INSTRUCTIONS, SIGNS AND MESSAGES IN THIS MANUAL AND ON THE LIFT TRUCK.**

**INJURY OR DEATH TO YOU OR OTHER PERSONNEL WILL OCCUR IF YOU DO NOT FOLLOW THESE INSTRUCTIONS AND MESSAGES.**

**STAY ALERT!**



# SUMMARY OF SAFE OPERATING PROCEDURES

1. Do not operate this truck unless you have been trained and authorized to do so. Read all warnings and instructions in operator's manuals and on this truck.

2. Do not operate this truck until you have checked its condition. Give special attention to Tires, Horn, Lights, Battery, Controller, Lift and Tilt Systems including forks and attachments, chains, cable and limit switches, brakes, steering mechanism, fuel system, and guards.

3. Operate truck only from designated operating position. Never place any part of your body into the mast structure, between the mast and the truck, or outside the truck. Do not carry passengers.

4. Do not operate truck without overhead guard, unless conditions prevent use of a guard. Use special care if operation without overhead guard is required.

5. Do not handle loads which are higher than the load backrest or load backrest extension unless load is secured so that no part of it could fall backward.

6. Do not handle unstable or loosely stacked loads. Use special care when handling long, high or wide loads to avoid losing the

load, striking bystanders, or tipping the truck.

7. Do not overload truck. Check capacity plate for load weight and load center information.

8. Lift trucks will tip over if not properly operated. Start, stop, travel, steer and brake smoothly. Slow down for turns and on uneven or slippery surfaces that could cause truck to slide or overturn. Use special care when traveling without load as the risk of overturn is greater.

9. Elevate forks or other lifting mechanism only to pick up or stack a load. Lift and lower with mast vertical or tilted slightly back — NEVER FORWARD. Watch out for obstructions, especially overhead.

10. Operate tilting mechanism slowly and smoothly. Do not tilt forward when elevated except to pick up or deposit a load. When stacking, use only enough backward tilt to stabilize load.

11. Travel with load or lifting mechanism as low as possible and tilted back. Always look in direction of travel. Keep a clear view and when load interferes with visibility, travel

with load or lifting mechanism trailing (except when climbing ramps).

12. Use special care when operating on ramps — travel slowly, and do not angle or turn. When truck is loaded, travel with load uphill. When truck is empty, travel with lifting mechanism downhill.

13. Observe applicable traffic regulations. Yield right-of-way to pedestrians. Slow down and sound horn at cross aisles and wherever vision is obstructed.

14. When using forks, space forks as far apart as load will permit. Before lifting, be sure load is centered and forks are completely under load.

15. Do not allow anyone to stand or pass under load or lifting mechanism.

16. Never lift or transport personnel on the forks of a lift truck. Use a manlift specifically designed for this purpose. When operating rider order selector trucks, hook the chain to the safety bars, and put the safety belt on.

17. Before getting off truck, neutralize travel control, fully lower lifting mechanism and set parking brake. When leaving truck unattended, also shut off power.

# TW20/25/30/40



I-142

Three - Wheel  
Electric  
2000#/4000# Rated Capacity

# EC300-20/30



Four - Wheel  
Electric  
2000#/3000# Rated Capacity





# Safety



13136

5. Never operate a lift truck with wet or greasy hands or shoes.

6. Before operating any lift truck test horn, brakes, parking brake, steering, lift and tilt controls, directional controls and other devices for proper operation. Report any improper operation to the proper authority.

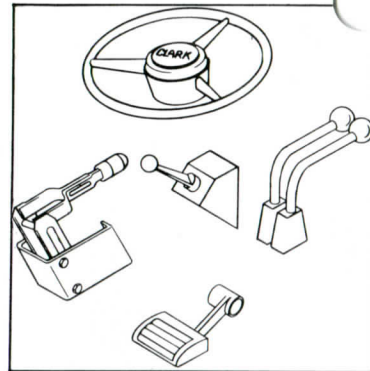

13138

13137

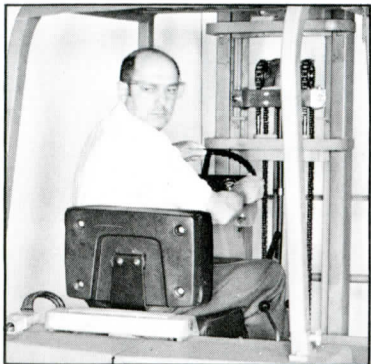

7. Always look all around truck before moving it in any direction. Then, remember to start and stop slowly and smoothly.

8. Operate truck only in designated truck routes. Keep operating aisles clear. One-way traffic is recommended. If this is not practical heed highway regulations and drive to right of aisle centerline.

13139

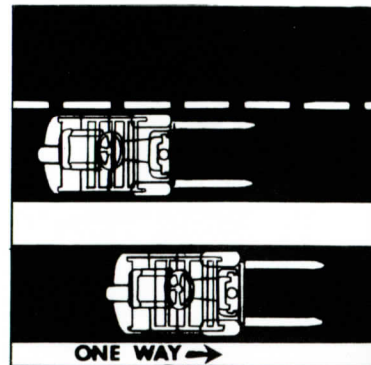

## Safety

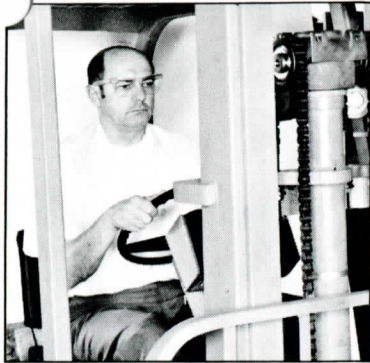

13140

9. Be alert for pedestrians, other trucks or obstacles in your path of travel.

10. Sound horn at all corners, exits, entrances, and when approaching pedestrians or by-standers.

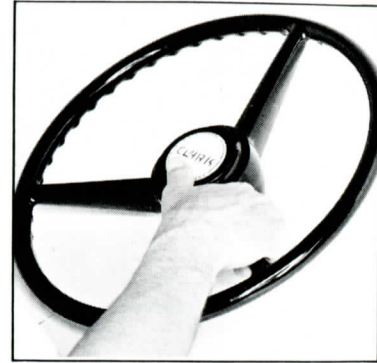

13141

13087



11. Obey all posted traffic rules and warning signs.

12. Maintain a safe distance from the truck ahead of you at all times.

Assure ample distance to stop smoothly and safely, should the need arise.

13142





## Safety

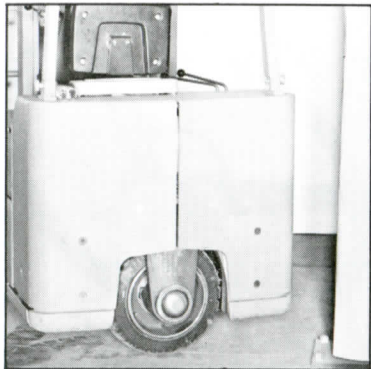

13143

13. Be aware of rear end swing and be alert to prevent rear end swing damage to material in your operating area.

14. Be aware of the position of your fork tips when truck is in motion. Be alert to prevent striking anything with fork tips.

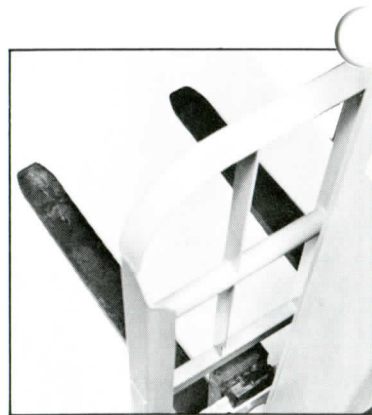

13145

13144

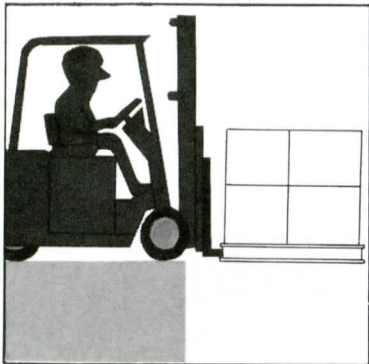

15. Be extremely cautious when operating truck near edge of loading dock.

16. Make sure vehicle being entered has been blocked to prevent accidental roll. Bridge plates must have adequate strength, width, minimum 3" high guard rails each side and be properly secured.

13146

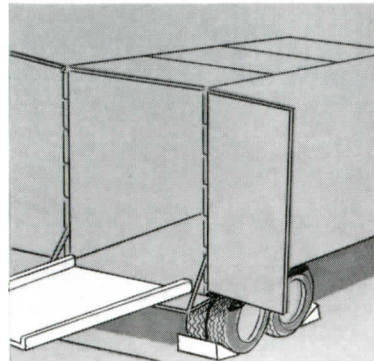

# Safety



13147

17. Never allow stunt riding or indulge in horseplay when operating a fork lift truck.

18. Never use your truck to push or tow another. Never allow your truck to be pushed or towed by another.

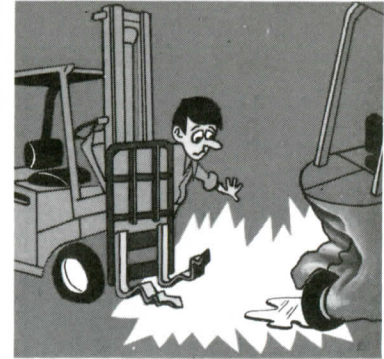

13149

Should a truck become disabled and require moving, notify the proper authority immediately.

13148

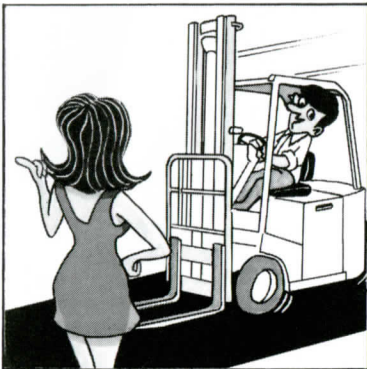

19. Never carry unauthorized passengers.

20. Know the rated capacity of your truck and its attachment (if any) and never exceed it. Study your truck data capacity plate and learn the facts stamped in areas 1 thru 8.

13095

<b>CLARK EQUIPMENT</b>		1
INDUSTRIAL TRUCK DIVISION		BATTLE CREEK MICH
MODEL NO.		TYPE 3
SERIAL NO.	2	
ATTACHMENTS		4
LOAD C G C		
A B		
FLOOR		
APPROX. WT. ALL TRUCKS		
APPROX. WT. ELECTRICS ONLY		
BATTERY WT.		
CAPACITY		
LESS BATT - ELECTRICS		6
WITH MAX. BATT. WT.		
MAX	7	MIN
AH		NO.
LBS		VOLTS
8		
FOR OTHER CAPACITIES, CONSULT MANUFACTURER		
AS RELEASED FROM FACTORY THIS TRUCK MEETS THE DESIGN SPECIFICATIONS ESTABLISHED IN AMERICAN NATIONAL STANDARD FOR POWERED INDUSTRIAL TRUCKS, PART II ANSI B 56.1-1969		
		PT. NO. 2315709

## Safety

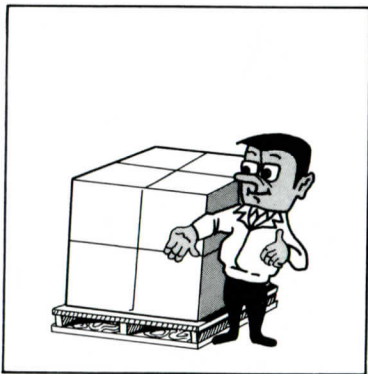

13094

21. Thoroughly inspect load to be moved for overload and/or poor balance. If the safety of the load is questionable, don't move it.

22. Unstable loads are a hazard to you and to your fellow workers. Always make certain that your load is well stacked and evenly positioned across both forks.

Never attempt to lift a load with only one fork.

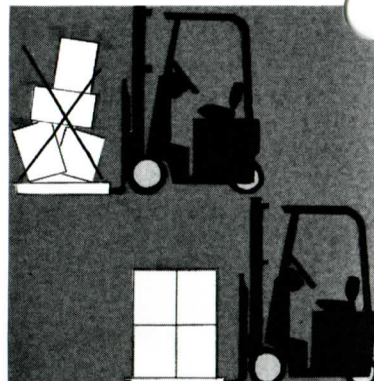

13151

13150

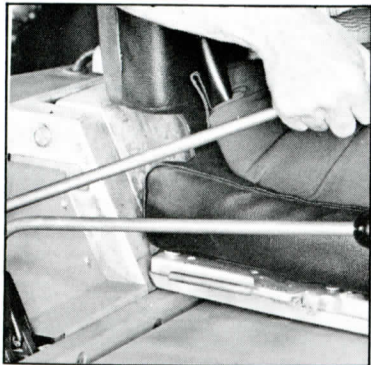

23. Before lifting check to insure adequate unobstructed overhead clearance.

Gradually and smoothly pull up (TW) or back (EC300) on control lever nearest your right side.

Release lever to stop lift at desired level.

24. Push down (TW) or forward (EC300) on control lever nearest your right side to lower load.

Descent may be stopped at desired point by releasing level.



13152

## Safety



13153

25. Always travel with load near floor and upright tilted back to cradle load.

Never lift or lower load while truck is in motion.

26. Never permit anyone to stand or walk under elevated forks or other attachments if machine is so equipped.

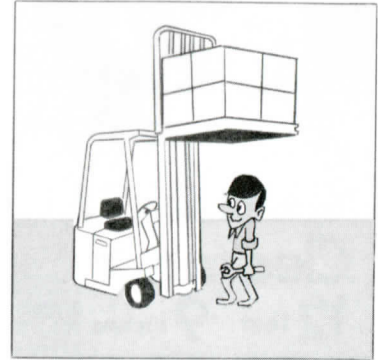

13155

13133

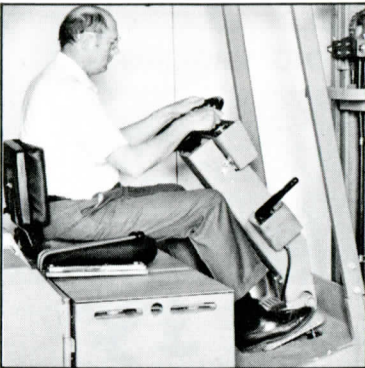

27. Remain seated at all times and keep head, hands, arms, feet and legs within the confines of the operators compartment. Never reach into upright for any reason.

28. Slow down for turns, ramps, bumps, cross aisles, congested areas, wet or slippery floors and at all times when visibility is restricted.

13103

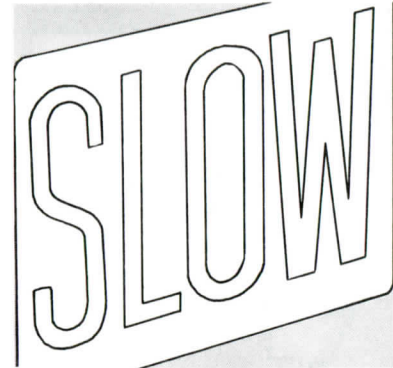



## Safety

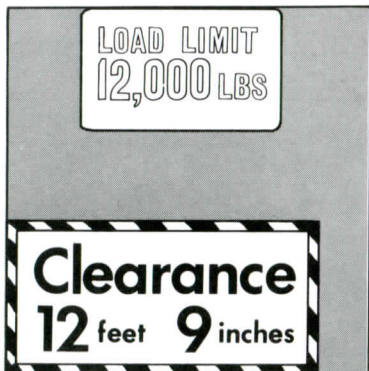

13102

13105

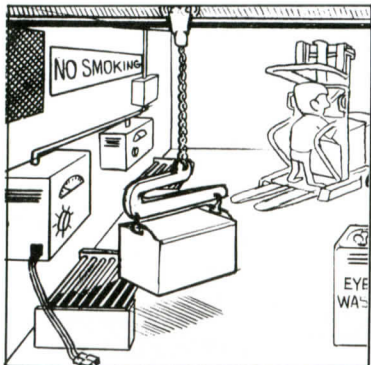

29. Know and observe floor load limits and overhead clearances in all operating areas.

31. Batteries should be serviced or recharged only in designated charging areas and only by personnel thoroughly trained in safe battery servicing practices.

30. Use caution when placing loads or traveling near water pipes, overhead sprinklers, electrical wiring, steam pipes, heaters or other fragile or dangerous equipment or material.

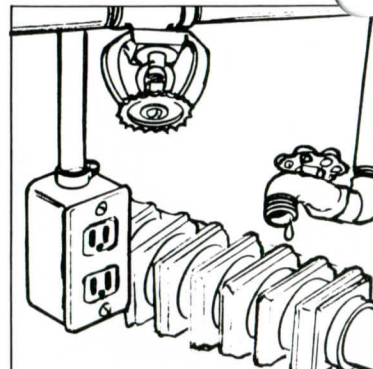

13104

13107

32. Never smoke or allow anyone to smoke in areas where batteries are being charged or in areas where fuels or other flammable fluids or materials are used or stored.

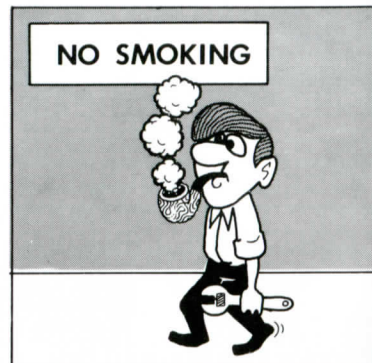

## Safety

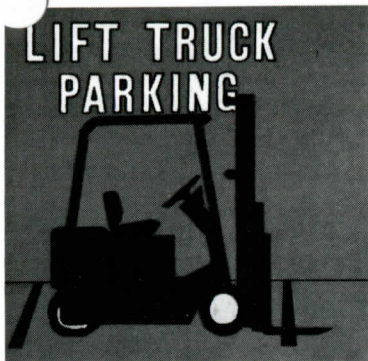

13156

33. Park lift trucks in designated areas only. Lower forks to floor, tilt upright forward, apply parking brake, place directional control in neutral, remove switch key and block drive wheels to prevent roll.

34. If truck is to be left unattended make certain that traffic aisles are not obstructed and leave truck as described in item 33.

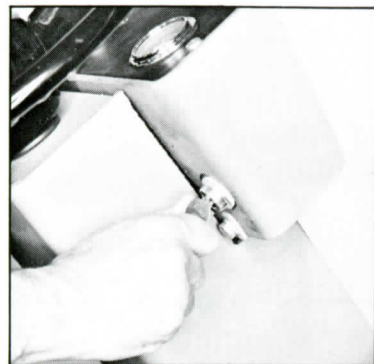

13157

13137

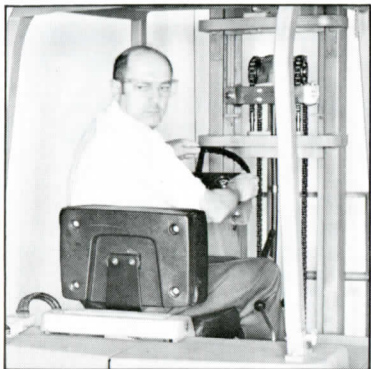

35. When handling bulky loads which, because of their size and shape, restrict your vision - operate your truck in reverse to improve visibility.

36. Overhead guards and load back rest extensions are for your protection. Make certain that they are securely mounted and undamaged before operating your truck.

13158

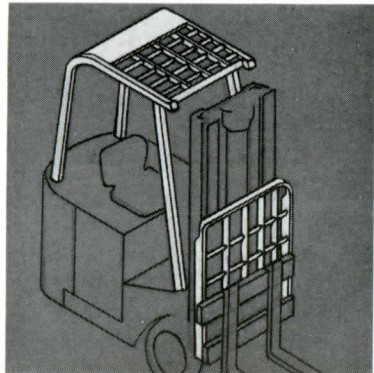



13159

13178

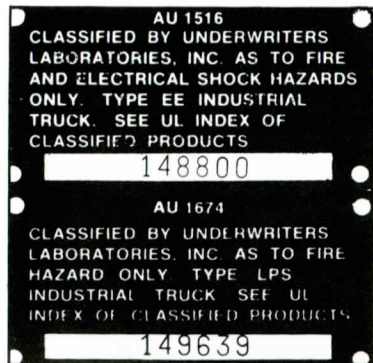

37. Be extremely careful of load end swing when operating with long loads such as lumber, pipe, etc.

38. Never lift or transport personnel on the forks of a lift truck. Use a manlift specifically designed for this purpose.

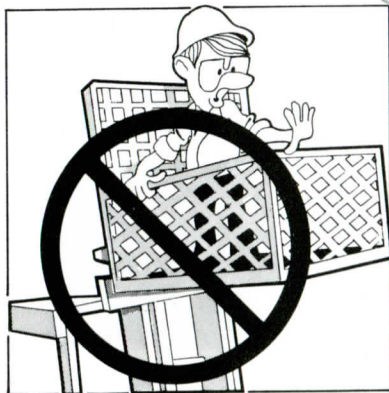

17631

13160

39. Know the construction type of your truck and never take an unauthorized truck into restricted or hazardous areas.

40. Follow a scheduled planned maintenance and lubrication program. All Adjustments and repairs must be performed by thoroughly trained and authorized personnel only.

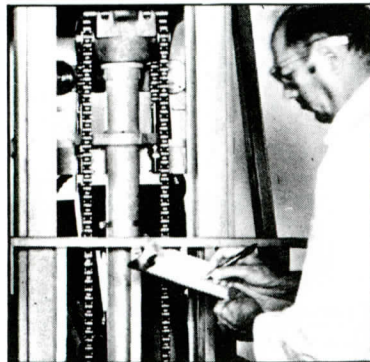



# Operator's Compartment & Controls

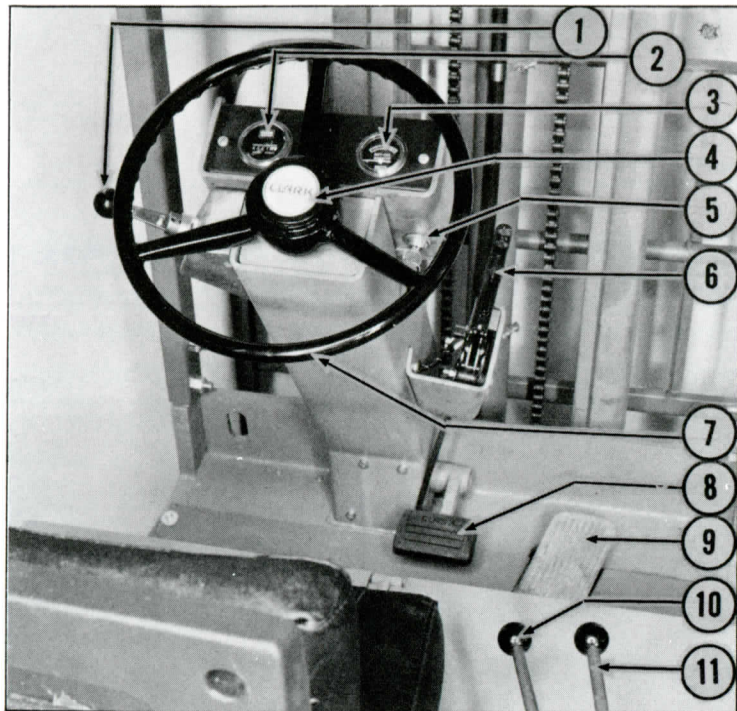

1. Directional Control Lever
2. Hour Meter
3. Battery Discharge Indicator
4. Horn Button
5. Key Switch
6. Parking Brake
7. Steering Handwheel
8. Brake Pedal (Some models are equipped with both right and left foot pedals)
9. Accelerator Pedal
10. Lift Control Lever
11. Tilt Control Lever

13161

## Before Operation

CLARK ELECTRIC TRUCK DRIVER'S DAILY CHECKLIST	
Check Before Start Of Each Shift	
Truck No. _____	Date _____
Operator _____	Supervisor's OK _____
Hour Meter Reading	
Start of Day _____	End of Day _____ Hrs. for Day _____
<input checked="" type="checkbox"/> Boxes Accordingly <input type="checkbox"/> OK <input type="checkbox"/> Needs Attention or Repair	
<b>Visual Checks:</b>	<b>Operational Checks:</b>
Obvious damage and leaks	Horn
Tire condition	Steering
Battery plug connection	Service brakes
<i>Note: Be sure the battery plug connection is tight.</i>	Battery Load Test
<input type="checkbox"/> Head and tail lights	<i>Note: Watch battery indicator while holding lift lever on full back tilt. If needle falls to red area, battery doesn't have sufficient charge to operate truck properly.</i>
<input type="checkbox"/> Warning lights	
<input type="checkbox"/> Hour meter	
<input type="checkbox"/> Other gauges and instruments	<input type="checkbox"/> Parking brake
<input type="checkbox"/> Battery Discharge indicator	<input type="checkbox"/> Seat brake
<i>Note: Key on, needle should indicate in green area.</i>	<input type="checkbox"/> Hydraulic controls

13124

13162



1. Each shift operator must complete an operators daily check list (available from your Clark Dealer). Make all checks listed and give completed check list to designated authority.

3. Note condition of drive wheels and tires. Tire pressure for pneumatic tired models must be maintained at 133 to 147 P.S.I.

Consult planned maintenance and adjustment manual for proper inflation procedures.

2. Walk around truck and visually check for damage and leaks. Note all damage and leaks on check list.

4. Check condition of steer wheel and tire assembly.

Note any apparent damage on check list.



13163

13164



## Before Operation



13165

5. Check condition of overhead guard and load backrest extension.

Make certain they are properly positioned and mounted securely.

13166

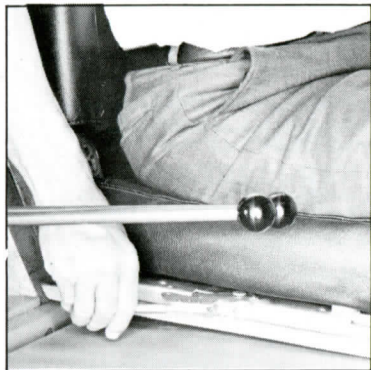

7. Seat adjustment is accomplished by releasing short lever at right side of seat.

Position seat to provide easy access to all controls, free lever and make sure seat is locked in desired position.

6. Remove blocks from drive wheels, enter operator's compartment and seat yourself.

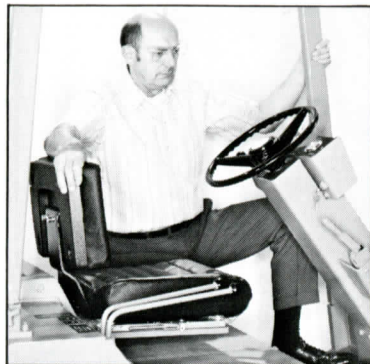

13167

8. Apply pressure to brake pedal with either foot. Pedal should be "firm". If pedal is "spongy" or "fades" under pressure do not operate the truck. Report brake deficiency immediately.

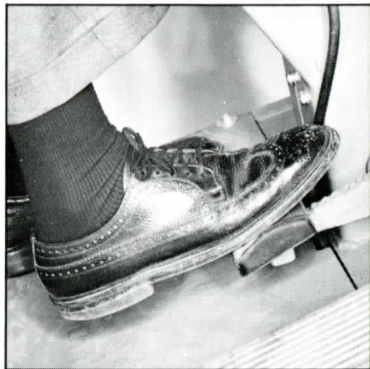

13135

## Before Operation

9. Insert key into switch and turn clockwise to "on" position.

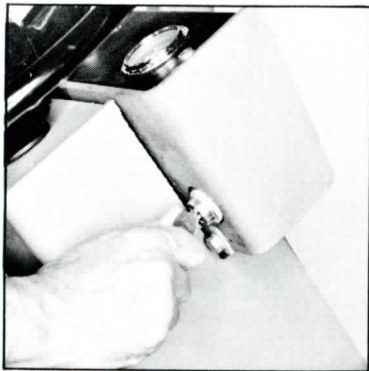

13157

10. Press horn button to determine if horn is operational.

If horn does not function properly report it immediately to designated authority.



13141

11. Check hour meter to insure that it is undamaged and functioning properly.

Report any malfunction or damage to the proper authority.

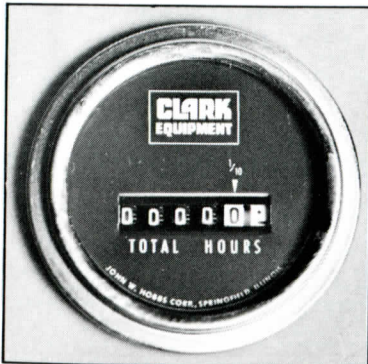

13225

12. Check battery discharge indicator for damage. Needle should remain in green area, check this meter frequently during operation.

Report any malfunction immediately.



13179



## Before Operation

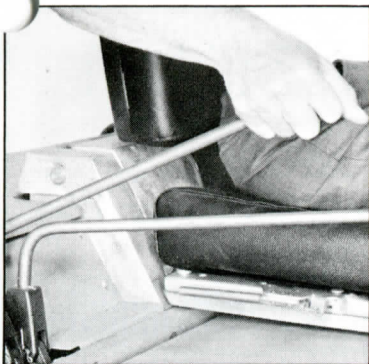

"TW" Tilt Control 13168

13. Gently pull up on "TW" tilt control lever and hold.

When upright reaches full back tilt check position of discharge indicator needle and release lever.

If needle does not remain in green, battery does not have sufficient charge.

Push down on lever to return upright to near vertical position and release lever.

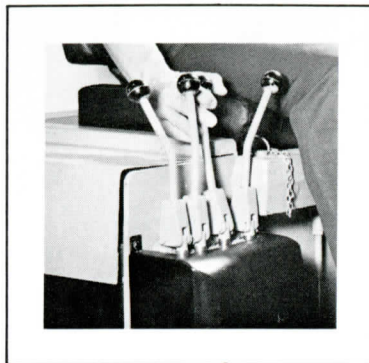

"EC300" Tilt Control 13281

14. Gently pull back on EC300 tilt control lever and hold until upright reaches full back tilt.

Check battery discharge indicator as outlined in Item 13.

Push lever forward to return upright to near vertical position and release lever.

Two outside levers are optional for aux. valve control. Consult your Supervisor for proper operation.

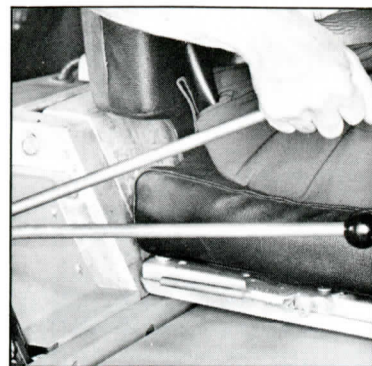

"TW" Lift Control 13150

15. Check for adequate unobstructed overhead clearance. Gently pull lift control lever up. Observe upright lift and report any erratic or unusual operation. Release lever to stop lift.

## Before Operation

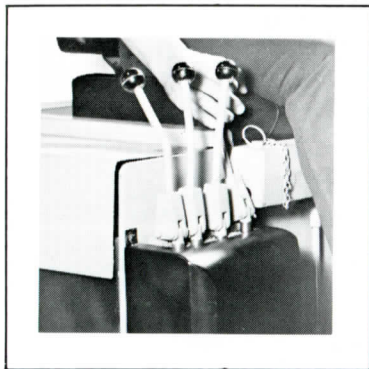

"EC300" Lift Control 13282

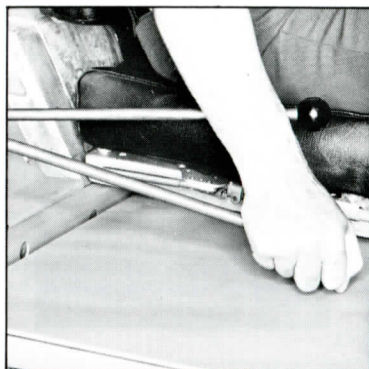

"TW" Lift Control 13152

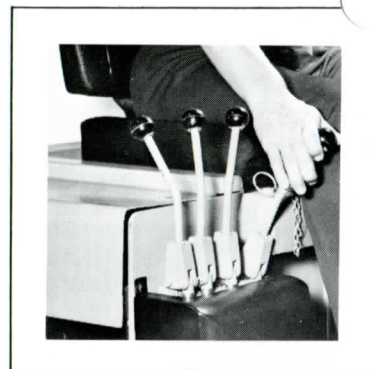

"EC300" Lift Control 13283

16. If operating an EC300 model check for adequate unobstructed overhead clearance then gently pull back on lift control lever and check upright lift as in Item 15.

Two outside levers are optional for aux. valve control. Consult your Supervisor for proper operation.

17. Push down on lift control lever and observe descent of upright. When forks reach floor release lever, it will return to neutral and stop upright lowering. Report any erratic or unusual operation immediately.

18. If you are operating an EC300 and have accomplished Step 16 - push forward on the lift control lever and check descent of upright as described in Item 17.

Two outside levers are optional for aux. valve control. Consult your Supervisor for proper operation.

## Before Operation



13170

19. Check to insure unobstructed forward path of travel.

Apply service brake with either foot.

Place directional control switch lever in position for forward travel.

13171



21. Keep foot on service brake pedal and release hand parking brake.

20. Check steering operation by turning hand wheel to right and then to left. Return hand wheel to proper position for desired direction of travel.



13172

22. Place right foot on accelerator (release service brake if operating with left foot) and press gently until truck begins to move forward.

Release accelerator and apply service brakes to stop truck.

13173

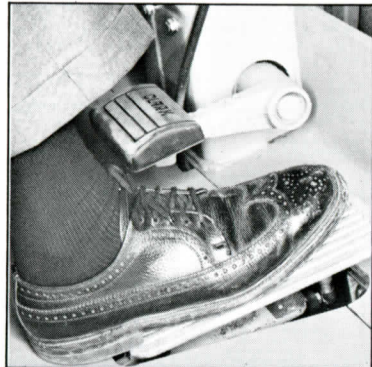



## Before Operation

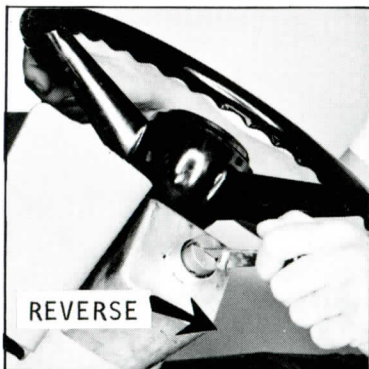

13174

23. Place directional control lever in reverse position, gently press accelerator pedal with right foot until truck moves backward. Release accelerator pedal, apply hand brake and move directional control lever to neutral.

24. Turn key switch counterclockwise to "off" position and remove key. Dismount from truck and block drive wheels to prevent accidental roll.

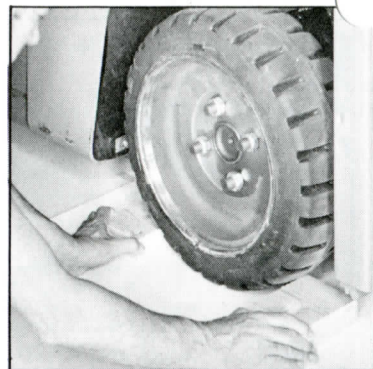

13175

13124

CLARK EQUIPMENT	
<b>ELECTRIC TRUCK DRIVER'S DAILY CHECKLIST</b>	
Check Before Start Of Each Shift	
Truck No. _____	Date _____
Operator _____	Supervisor's OK _____
<b>Hour Meter Reading:</b>	
Start of Day _____	End of Day _____ Hrs. for Day _____
<input checked="" type="checkbox"/> Beeps Accordingly <input type="checkbox"/> OK <input type="checkbox"/> Needs Attention or Repair	
<b>Visual Checks:</b>	<b>Operational Checks:</b>
<input type="checkbox"/> Obvious damage and leaks	<input type="checkbox"/> Horn
<input type="checkbox"/> Tire condition	<input type="checkbox"/> Steering
<input type="checkbox"/> Battery plug connection	<input type="checkbox"/> Service brakes
<b>Note:</b> Be sure the battery plug connection is tight.	<input type="checkbox"/> Battery Load Test
<input type="checkbox"/> Head and tail lights	<b>Note:</b> Watch battery indicator while holding till lever on full back tilt. If needle falls to red area, battery doesn't have sufficient charge to operate truck properly.
<input type="checkbox"/> Warning lights	<input type="checkbox"/> Parking brake
<input type="checkbox"/> Hour meter	<input type="checkbox"/> Seat brake
<input type="checkbox"/> Other gauges and instruments	<input type="checkbox"/> Hydraulic controls
<input type="checkbox"/> Battery Discharge indicator	
<b>Note:</b> Key on, needle should indicate in green area.	

25. Review operator's daily check list to make certain that it has been properly marked and turn it in to the designated authority.

## Operation

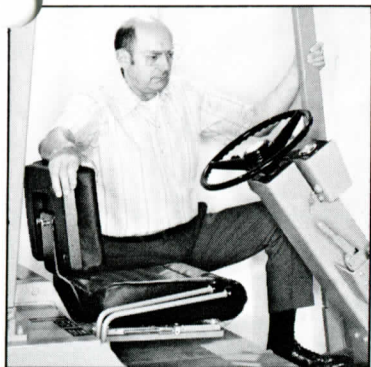

13167

1. Remove blocks at drive wheels, enter operator's compartment and seat yourself in operator's seat.

2. Adjust operator's seat to position which is comfortable for you and provides easy access to all hand and foot controls.

Make sure seat locks in selected position.

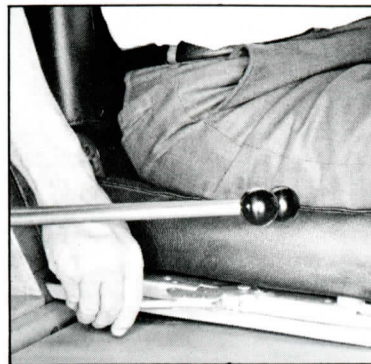

13166

13157

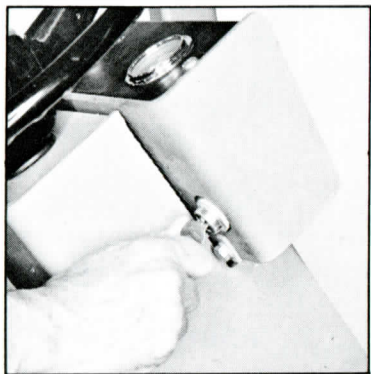

3. Insert key into switch and turn clockwise to "on" position.

4. Place foot on brake pedal and push down to apply the service brakes.



13135

## Operation

5. Release hand parking brake.



13171

6. Place directional control switch lever in proper position for desired direction of travel. Push to front for forward or pull back for reverse.



13174

13137

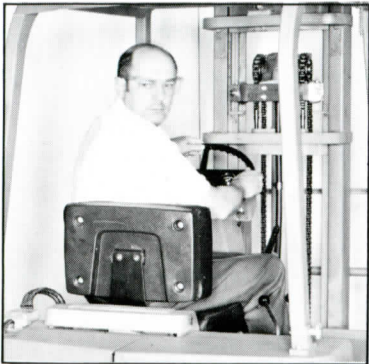

7. Check all around truck to insure that desired path of travel is unobstructed.

8. Carefully pull up (TW models) or back (EC300 models) on lift control lever to raise forks from floor slightly.

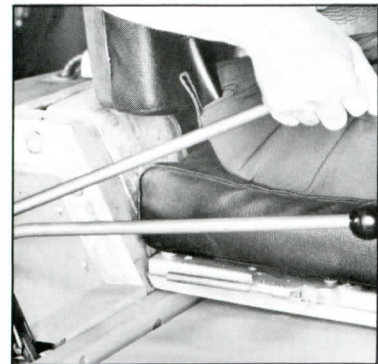

13150

## Operation



13168

9. Pull up (TW models) or back (EC300 models) on tilt control lever to tilt upright back slightly and raise fork tips from floor.

10. Place right foot on accelerator pedal and press gently until truck begins to move in desired direction. Depress accelerator smoothly until speed is increased to desired level.

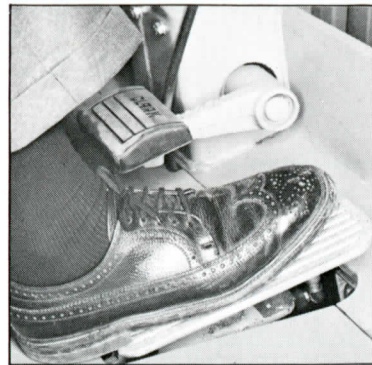

13173

13140

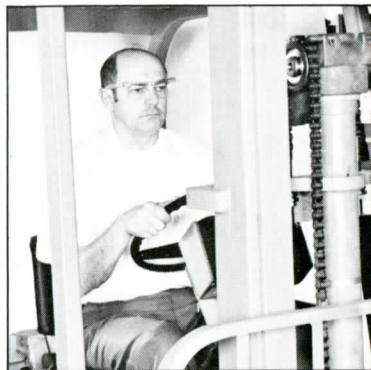

11. Always be alert for pedestrians, other trucks or obstacles in your path of travel.

12. Always come to a complete stop before changing direction of travel from forward to reverse or reverse to forward.

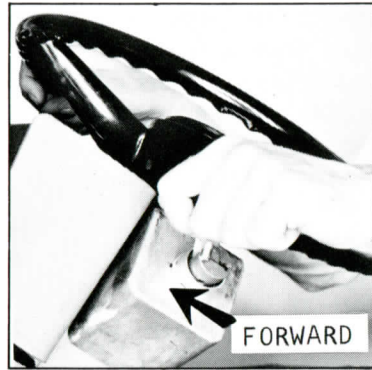

13170



## Operation

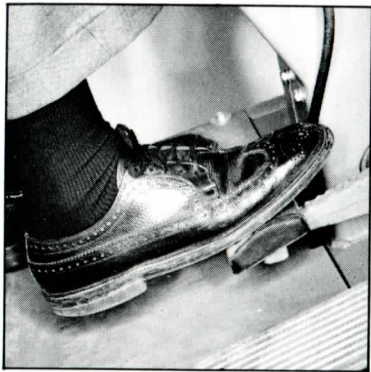

13135

13. To stop truck release accelerator pedal and place right foot on service brake pedal. Gently press down on brake pedal to come to a smooth stop.

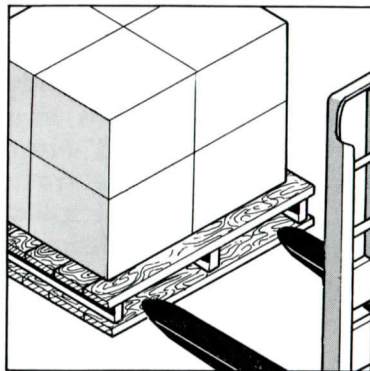

13203

14. Remember to enter load slowly and squarely.

Load should be centered and forks should be near outside edges, if they are not...

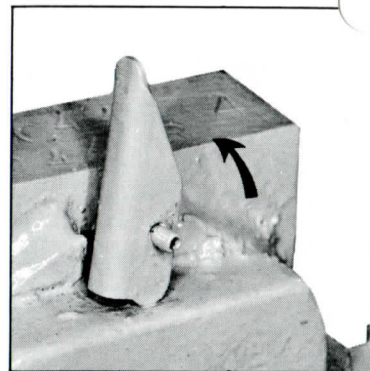

10758

15. Adjust them by lifting fork lock lever and sliding forks to desired position. Then...

## Operation

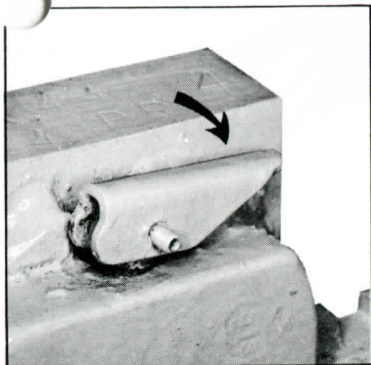

10759

16. ...Remember to lower lever to lock forks securely into notch atop fork bar.

17. It's risky to drive down a ramp load first. Your truck can tip forward if the ramp is steep enough. Always back down slowly and never turn sideways on an incline.



13258



18. Use minimum forward and reverse tilt when stacking and unstacking loads.

Never tilt forward unless load is over stack or at low lift height.

19. Be constantly alert for unusual or erratic operation.

Report any malfunction immediately so that adjustments or repairs may be performed by thoroughly trained and qualified personnel.

13176

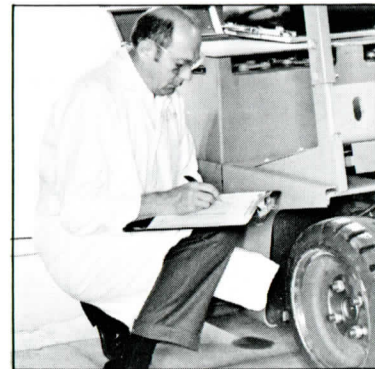

## Parking

1. Park lift trucks in designated parking areas only.

Do not obstruct traffic lanes or aisles.

2. Place directional control switch in neutral position.

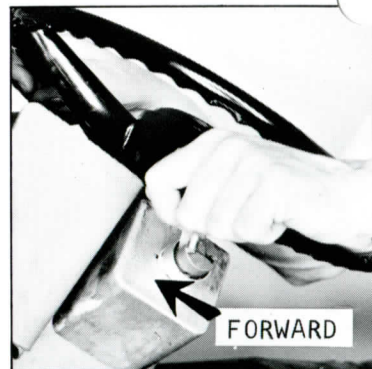

13170

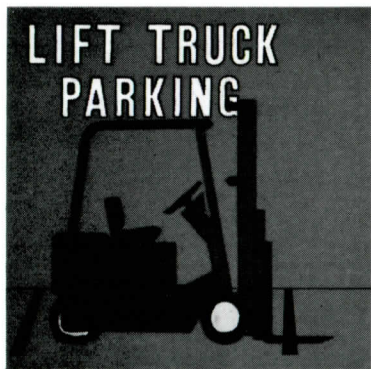

13156

3. Lower forks to floor.



13152

4. Tilt upright forward until fork tips rest on floor.

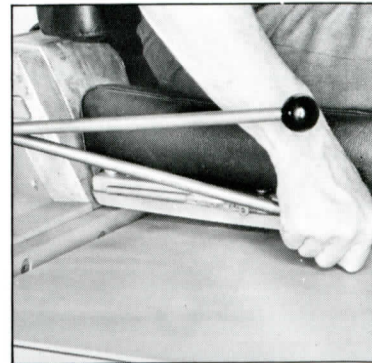

13169

## Parking

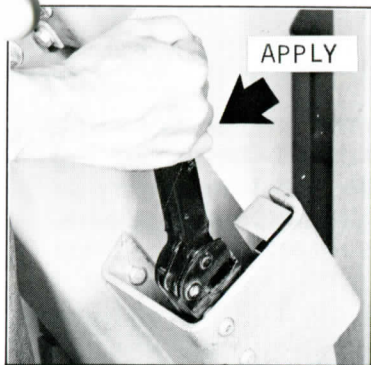

13177

13175

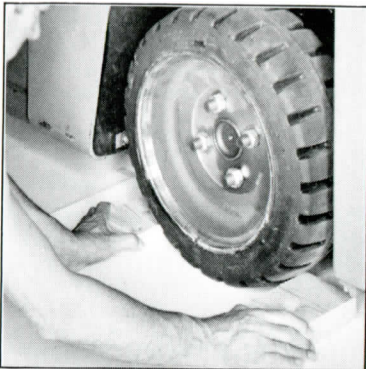

5. Apply hand parking brake.

6. Turn switch key counterclockwise to "off" position and remove key.

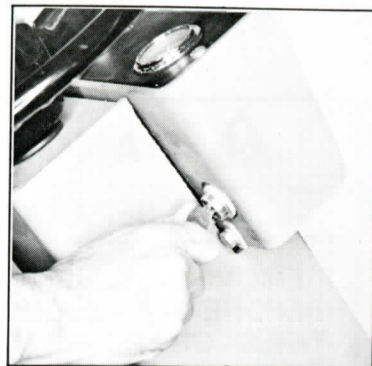

13157

7. Carefully dismount from truck and block drive wheels to prevent accidental roll.



# Wheel and Tire Maintenance



**DANGER**

## **RIM SEPARATION**

REMOVE THE AIR FROM TIRES BEFORE DOING ANY WORK ON TIRES OR RIMS. MULTI-PIECE RIMS CAN SEPARATE WITH ENOUGH FORCE TO CAUSE INJURY OR DEATH.

Federal and State laws require persons to be fully trained and qualified before doing maintenance on wheels and tires. Injury or death can result from the explosive separation of rim components if service procedures are not done correctly.

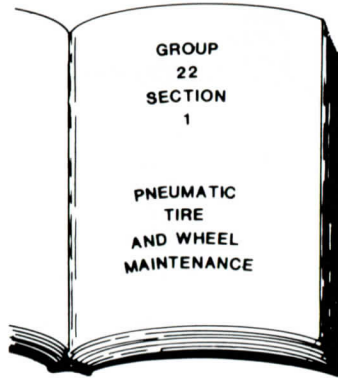

24309

1. Refer to the planned maintenance manual for complete wheel and tire servicing procedures.



18924

2. Inspect wheels, tires and mounting parts for condition and security daily.



24307

3. Do not stand in front of or in the trajectory path of wheels when checking or adding air pressure. Stand to the side and use a gauge with a long handle and a self attaching air chuck on the hose.

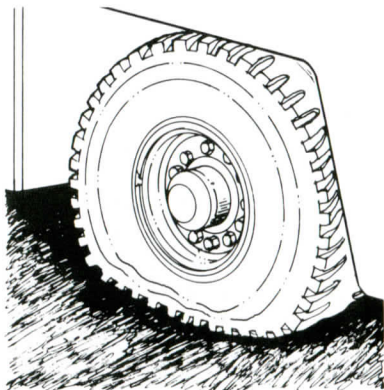

24308

4. Do not put air into a tire which has gone flat or has less than 80 percent of recommended pressure. Check for cause of air loss and confirm that the wheel and tire are safe to use.

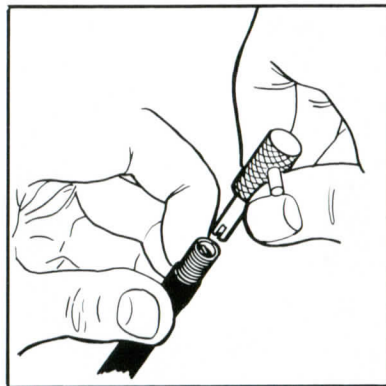

18631

5. Remove air from the tire before removing wheel clamping nuts (two piece wheels) or rim locking rings on multi-piece rims.



24306

6. Always use a safety cage to inflate tires after servicing.







## For Handy Reference

RECORD THE FOLLOWING INFORMATION PERTAINING TO YOUR TRUCK

Model No. ....

Serial No. ....

Attachments .....

Truck Weight W/Battery .....

Truck Rated Capacity .....

Gross Truck Weight (W/Battery and Rated Load) .....

Customer Truck Identification No. ....



Additional copies of this manual may be purchased from  
YOUR AUTHORIZED CLARK DEALER.

---

---

**CLARK**<sup>®</sup> Material Handling  
Company

Lexington, KY 40511  
Printed in USA