



INDUSTRIAL TRUCK DIVISION



OPERATORS MANUAL

FOR

GOVERNMENT

CY 6044

0-176

CLARK EQUIPMENT COMPANY

PUBLISHED BY

TECHNICAL SERVICE DEPARTMENT,
BATTLE CREEK, MICHIGAN, U.S.A.

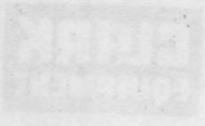

INDUSTRIAL TRUCK DIVISION



OPERATORS MANUAL

FOR

GOVERNMENT

CY-6044

0-170

CLARK EQUIPMENT COMPANY

PUBLISHED BY

TECHNICAL SERVICE DEPARTMENT
BATTLE CREEK MICHIGAN, U.S.A.

SAFETY INSTRUCTIONS FOR MAINTAINING INDUSTRIAL TRUCKS

Powered industrial trucks may become hazardous if adequate maintenance is neglected. Therefore, adequate maintenance facilities, personnel and procedures should be provided.

Maintenance and inspection of all powered industrial trucks should be performed in conformance with the recommendations in this Manual and the following practices:

1. Only qualified and authorized personnel should be permitted to maintain, repair, adjust, and inspect industrial trucks, and a scheduled preventive maintenance, lubrication, and inspection system should be followed.
2. When truck is to be parked for maintenance: Turn off engine, lower lifting mechanism, place directional controls in neutral, (clutch type trucks may be left in gear) apply parking brake and chock wheels.
3. Before working on truck raise wheels free of floor or disconnect power source. Use chocks or other positive truck positioning devices and block carriage, innermast(s), or chassis before working under them. Before working on engine fuel system of: (a) Gasoline powered trucks with gravity feed fuel systems, be sure fuel shutoff is closed; (b) LP gas powered trucks, close LP-gas cylinder valve and run engine until fuel in system is depleted and engine dies.
4. When starting engine place shift levers in neutral and depress clutch (or brake pedal on automatic transmissions).
5. Avoid fire hazards and have fire protection equipment present. Do not use an open flame to check level, or for leakage, of fuel, electrolyte or coolant. Do not use open pans of fuel or flammable cleaning fluids for cleaning parts.
6. Properly ventilate work area, vent exhaust fumes and keep shop clean and floor dry.
7. Use hoisting equipment for heavy lifts.
8. Handle LP Gas cylinders with care. Do not drop, dent, or damage in any way.
9. Brakes, steering mechanisms, control mechanisms, warning devices, lights governors, lift overload devices, safety guards and safety devices should be inspected regularly and maintained in a safe operating condition.
10. All parts of lift and tilt mechanisms and frame members should be carefully and regularly inspected and maintained in a safe operating condition.
11. Special trucks or devices designed and approved for hazardous area operation should receive special attention to ensure that maintenance preserves the original approved safe operating features.

(Continued)

SAFETY INSTRUCTIONS FOR MAINTAINING INDUSTRIAL TRUCKS

12. Fuel systems should be checked for leaks and condition of parts. Extra special consideration should be given in the case of a leak in the fuel system. Action should be taken to prevent the use of the truck until the leak has been corrected.
13. All hydraulic systems should be regularly inspected and maintained in conformance with good practices. Tilt cylinders, valves, and other similar parts should be checked to assure that "drift" has not developed to the extent that it would create a hazard.
14. Capacity rating, operation and maintenance instruction plates, tags, or decals should be maintained in legible condition.
15. Batteries, motors, controllers, limit switches, protective devices, electrical conductors and connections should be inspected and maintained in conformance with good practices. Special attention should be paid to the condition of electrical insulation.
16. Industrial trucks should be kept in a clean condition to minimize fire hazards and facilitate detection of loose or defective parts.
17. Modifications and additions which affect capacity rating and safe operation should not be performed by the user without manufacturer's approval.
18. Care should be taken to assure that all replacement parts are interchangeable with the original parts and of a quality equal to that provided in the original equipment.



INDUSTRIAL TRUCK DIVISION



P L E A S E N O T E

I N S T R U C T I O N S O N U S E O F M A N U A L

This Operator's Manual is published as a service reference guide and includes Specifications, Operating Instructions, Lubrication and Preventive Maintenance Instructions, and Trouble Shooting Guide.

The TABLE OF CONTENTS for this manual is printed on green paper and is placed at the front for easy reference. A separate INDEX (also printed on green paper) is placed in front of the Lubrication and Preventive Maintenance Section.

Lubrication and Preventive Maintenance Instructions are listed under the TIME INTERVALS that they should be performed.

The TIME INTERVAL is part of the page number and code number.

Example: 8H 002-0; 8H is the TIME INTERVAL (8 operating hours), 002 is the PAGE NUMBER, and -0 is a CODE NUMBER that you as a customer should disregard. The dash number or code number is for the benefit of the publisher only.

The INDEX is set up under the TIME INTERVALS that the Lubrication and Preventive Maintenance should be performed.

Example:	(8 Hours)	Time Interval (H=Hours)	&	Page Number (000-)
	Hydraulic Sump Tank, level check...	8H		503
	Brake Pedal Free Travel, check.....	8H		303

The above states to check the sump tank fluid level every 8 operating hours and refer to page 503 for fluid recommendations etc. Also, to check brake pedal free travel at this interval and turn to page 303 for instructions.

Turn to the eight (8) hour section (8H) and then to the page listed — 503 or 303 etc. The instructions covered therein will pertain only to the checks or adjustments that should be performed at this TIME INTERVAL.

If, for instance, the Brake Pedal Free Travel is incorrect, you would then refer to the INDEX for "Brake Pedal Free Travel, adjust" which would be listed in the TIME INTERVALS following the 8 hour section.

<u>Example:</u>	(100 Hours)	Time Interval (H=Hours)	&	Page Number (000-)
	Brake Pedal Free Travel, adjust....	100H		302

Turn to the one hundred hour section (100H) and then to



INDUSTRIAL TRUCK DIVISION



(continued)

I N S T R U C T I O N S O N U S E O F M A N U A L

page 302. Complete instructions as to the importance of pedal free travel, the method to check and adjust for correct free travel with illustrations are included therein.

N O T E

YOU WILL NOTE THAT AT THE BEGINNING OF EVERY SECTION A LUBRICATION AND PREVENTIVE MAINTENANCE ILLUSTRATION IS SHOWN GIVING THE LOCATION OF THE COMPONENTS TO BE SERVICED.

It is impossible to cover all types of machine operations in one manual. Operating conditions should determine the lubrication and maintenance intervals. Common sense and a close observance can best determine the frequency with which you should service your machine.

The care you give your machine will greatly determine the satisfaction and service life that you will obtain from it. A definite maintenance program should be set up and followed. Haphazard maintenance will only lead to faulty performance and short life.



INDUSTRIAL TRUCK DIVISION



TABLE OF CONTENTS

<u>Page</u>	<u>Description</u>
A001	Instruction On Use of Manual
A003	Table of Contents
B001	Illustration of Machine
B003	Specifications
B031	New Machine 50 Hour Inspection

OPERATIONS

C002	Overall Controls
C003	Instrument Indicators
C103	Starting and Operating Instructions
C303	To Move, Stack and Lower Loads. Safety and Operating Suggestions

LUBRICATION AND PREVENTIVE MAINTENANCE

<u>Time Interval (H=Hours)</u>	<u>Page Number (0000-1)</u>	<u>Description</u>
H	001	Index
8H	000	<u>8 Hour Lubrication and Preventive Maintenance Illustration</u>
8H	001	Horn, Fuel Tank and System Fuses
8H	003	Crankcase Oil Level check; Recommended Lubricants
8H	103	Cooling System check
8H	203	Instrument Indicators, check
8H	303	Brake Pedal Free Travel check; Parking Brake Operation check
8H	403	Engine Air Cleaner Service
8H	503	Hydraulic Sump Tank Level check; Hydraulic Control Lever Operation check
8H	602	Tires, Inspect
100H	000	<u>100 Hour Lubrication and Preventive Maintenance Illustration</u>
100H	001	Transmission & Differential Level check; Fuel Tank and Lines Inspect
100H	003	Engine Crankcase drain & refill; Crankcase Ventilation inspect, Engine Oil Filter Change
100H	103	Cooling System inspect; clean radiator fins
100H	203	Fan and Generator Belt adjustment
100H	302	Brake Pedal Free Travel check
100H	303	Brake Pedal Free Travel adjust; Master Cylinder level check
100H	403	Lift and Tilt Cylinders inspect; Lift Chains check and adjust; visually inspect all wiring and hydraulic piping; lubricate all miscellaneous linkage.
100H	503	Hydraulic Sump Tank Breather inspect
100H	603	Steering Gear verify lubricant level; Battery inspect
100H	702	Lubrication Chart
500H	000	<u>500 Hour Lubrication and Preventive Maintenance Illustration</u>
500H	001	Fuel Pump Strainer clean; Fuel Pump Operation check
500H	003	Converter, Transmission and Transfer Case drain & refill; Transmission Oil Filter change
500H	103	Hydraulic Sump Tank Oil Filter change
500H	202	Steering Gear adjust
500H	302	Steering Axle and Linkage adjust
500H	403	Manifolds check security of mounting; Universal Joints check; Nuts, Bolts and Cap Screws security check



INDUSTRIAL TRUCK DIVISION



TABLE OF CONTENTS

LUBRICATION AND PREVENTIVE MAINTENANCE

<u>Time Interval</u> (H=Hours)	<u>Page Number</u> (0000-)	<u>Description</u>
1000H	000	<u>1000 Hour Lubrication and Preventive Maintenance Illustration</u>
1000H	001	Engine Tune Up; Air Cleaner, Fuel Pump Service
1000H	003	Engine Tune Up; Cylinder Head Stud Nuts, Intake and Exhaust Manifolds, Crankcase Ventilation; Intake and Exhaust Valve Clearance adjust
1000H	004	Engine Tune Up; Intake and Exhaust Valve Clearance adjustments
1000H	103	Engine Tune Up; Compression test, Spark Plugs inspect
1000H	203	Engine Tune Up; Distributor
1000H	204	Engine Tune Up; Tach Dwell Meter
1000H	303	Engine Tune Up; Contact Point adjustment; Ignition Timing
1000H	403	Engine Tune Up; Vacuum Test and Carburetor adjustment
1000H	503	Engine Tune Up; Governor adjustment
1000H	603	Starting Motor inspect
1000H	703	Generator inspect
1000H	803	Steering Wheel Bearings clean and repack; adjust
1000H	805	Drive Wheel Bearings clean and repack; adjust
1000H	913	Bleeding Brake System
1000H	914	Bleeding Hydratork Inching System
1000H	1003	Brake Lining Clearance adjust
1000H	1103	Hand Brake adjustment
1000H	1202	Cooling System inspect and clean
1000H	1304	Differential drain and refill
1000H	1403	Hydraulic Sump Tank drain and refill
1000H	1503	Main Hydraulic System Pressure checks
1000H	1703	Transmission Stall and Pressure checks
1000H	1793	Neutral Starting Switch
1000H	1803	Upright Roller Adjustments

TROUBLE SHOOTING GUIDE

<u>Page</u>	<u>Description</u>
TS 001	Engine
TS 251	Fuel System
TS 321	Cooling System
TS 341	Ignition System
TS 361	Starter
TS 381	Generator
TS 401	Battery & Horn
TS 483	Drive Axle
TS 521	Steering Axle
TS 541	Brake System
TS 653	Hydraulic System
TS 963	Hydratork Drive (Transmission)



INDUSTRIAL TRUCK DIVISION



SPECIFICATIONS

CY100/120, CHY100/120

COOLING SYSTEM CAPACITY 15 quarts

FAN BELT DEFLECTION (long span)..... 1/2"

BRAKE PEDAL FREE TRAVEL 3/16 to 1/2"

TORQUE CONVERTER (C Models) diameter..... 11"
Torque Multiplication.... 2 to 1

TRANSMISSION

Speeds Forward..... 4
Speeds Reverse..... 4

Capacity13 quarts

STEERING AXLE

Toe-in 0 degrees
Camber Angle 1 degree
Caster 0 degrees

Left hand turning radius angle
Left Wheel..... 72°
Right Wheel..... 48° 20'

Right hand turning radius angle
Left Wheel..... 48° 20'
Right Wheel 72°

DRIVE AXLE

Ratio 6.33 to 1
Capacity 14 pints

MAIN HYDRAULIC PUMP

Type vane
Capacity 17 G.P.M. @ 1200 engine R.P.M.

STEERING PUMP

Type vane
Capacity.....
6 G.P.M. at 1200 engine R.P.M. 1500 P.S.I.

HYDRAULIC VALVE

Pressure Relief Valve Setting....2000 P.S.I.

ELECTRICAL SYSTEM

Brush tension 35-40 oz.
No Load Test 10.6 volts
49 amps. min.
76 amps. max.
Lock Test 435 amps.
10.5 lb. ft. torque min.
approximately 5.8 volts.

GENERATOR

Brush spring tension 28-30 oz.
Field current 80°F 1.69-1.79 amps.
12 volts
Cold output..... 25 amps.
14 volts
at approx. 1970 R.P.M.
Hot Output..... 25 amps.
14 volts
at approx. 2225 R.P.M.

VOLTAGE REGULATOR

Voltage regulator air gap075 in.
Voltage setting range....14.2-15.2 @ 85° F.

Current regulator air gap075 in.
Current setting range.....23 to 27 amps.

DISTRIBUTOR

Start advance5° to 2.5° @ 300 R.P.M.
Maximum advance.. 7.5° to 9.5° @ 1100 R.P.M.

Breaker point opening..... .022 in.

Cam angle range 31° to 34°

Rotation (cap end) cc.

Ignition Timing T.D.C.

GAS ENGINE GOVERNED R.P.M. (No Load) 2600

Drive wheel stud nut torque.....
425-450 ft. lbs. (Dry Thread)

Steer Wheel Stud Nut Torque.....
425-450 ft. lbs. (Dry Thread)

Steering Gear Pitman Arm Lock Nut Torque.....
120-130 foot pounds

Steering Gear Mounting Bolts and Clamp Bolt
Torque.....80-90 foot pounds



INDUSTRIAL TRUCK DIVISION

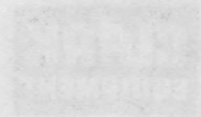

REPLACEMENT

CHRYSLER

GENERATOR

12-10-00
 12-10-00
 12-10-00
 12-10-00
 12-10-00
 12-10-00
 12-10-00
 12-10-00
 12-10-00
 12-10-00
 12-10-00
 12-10-00

VOLTAGE REGULATOR

12-10-00
 12-10-00
 12-10-00
 12-10-00
 12-10-00
 12-10-00
 12-10-00
 12-10-00
 12-10-00
 12-10-00
 12-10-00

DISTRIBUTION

12-10-00
 12-10-00
 12-10-00
 12-10-00
 12-10-00
 12-10-00
 12-10-00
 12-10-00
 12-10-00
 12-10-00
 12-10-00

POTENTIAL (CAN ONLY)

12-10-00
 12-10-00
 12-10-00
 12-10-00
 12-10-00
 12-10-00
 12-10-00
 12-10-00
 12-10-00
 12-10-00
 12-10-00

STEERING LOCK (MANUAL LOCK KIT)

12-10-00
 12-10-00
 12-10-00
 12-10-00
 12-10-00
 12-10-00
 12-10-00
 12-10-00
 12-10-00
 12-10-00
 12-10-00

COOLING SYSTEM CAPACITY

12-10-00
 12-10-00
 12-10-00
 12-10-00
 12-10-00
 12-10-00
 12-10-00
 12-10-00
 12-10-00
 12-10-00
 12-10-00

STEERING

12-10-00
 12-10-00
 12-10-00
 12-10-00
 12-10-00
 12-10-00
 12-10-00
 12-10-00
 12-10-00
 12-10-00
 12-10-00

STEERING ROLL

12-10-00
 12-10-00
 12-10-00
 12-10-00
 12-10-00
 12-10-00
 12-10-00
 12-10-00
 12-10-00
 12-10-00
 12-10-00

STEERING ROLL

12-10-00
 12-10-00
 12-10-00
 12-10-00
 12-10-00
 12-10-00
 12-10-00
 12-10-00
 12-10-00
 12-10-00
 12-10-00

DRIVE SHAFT

12-10-00
 12-10-00
 12-10-00
 12-10-00
 12-10-00
 12-10-00
 12-10-00
 12-10-00
 12-10-00
 12-10-00
 12-10-00

STEERING SHAFT

12-10-00
 12-10-00
 12-10-00
 12-10-00
 12-10-00
 12-10-00
 12-10-00
 12-10-00
 12-10-00
 12-10-00
 12-10-00

ELECTRIC SYSTEM

12-10-00
 12-10-00
 12-10-00
 12-10-00
 12-10-00
 12-10-00
 12-10-00
 12-10-00
 12-10-00
 12-10-00
 12-10-00



INDUSTRIAL TRUCK DIVISION



SPECIFICATIONS

L.P. Gas and Gasoline ENGINE TORQUE SPECIFICATIONS

Engines have many studs, bolts, and cap screws of special material and sizes and it is very important that care be exercised to torque all studs and bolts correctly.

The torque specifications, foot pounds, listed below MUST be followed in order to have the engine conform to the original specifications.

Size - Diameter	5/16"	3/8"	7/16"	1/2"	9/16"	5/8"
Cylinder Heads	-----	35-40	70-85	100-110	130-140	145-155
Manifolds	15-20	25-30	40-50	50-60	50-60	60-70
Gear Covers, Water Pumps, Front and Rear End Plates	15-20	25-30	50-55	80-90	-----	-----
Oil Pans	12-16	12-16	-----	-----	-----	-----

INDUSTRIAL TRUCK DIVISION

REPORT

1. Name and location of engine
 2. Model number

Engine and parts should be identified and any other information should be noted. It is very important that care be exercised to locate all parts and parts numbers. The engine specifications, load capacity, and other data should be noted. In order to have the engine and parts identified, the following information should be noted:

Part No.	Description	Part No.	Description	Part No.	Description	Part No.	Description
10-12	Cylinder head	10-11	10-10	10-9	10-8	10-7	10-6
10-10	10-9	10-8	10-7	10-6	10-5	10-4	10-3
	10-2	10-1	10-0	9-9	9-8	9-7	9-6
	9-5	9-4	9-3	9-2	9-1	9-0	8-9
	8-8	8-7	8-6	8-5	8-4	8-3	8-2
	8-1	8-0	7-9	7-8	7-7	7-6	7-5
	7-4	7-3	7-2	7-1	7-0	6-9	6-8
	6-7	6-6	6-5	6-4	6-3	6-2	6-1
	6-0	5-9	5-8	5-7	5-6	5-5	5-4
	5-3	5-2	5-1	5-0	4-9	4-8	4-7
	4-6	4-5	4-4	4-3	4-2	4-1	4-0
	3-9	3-8	3-7	3-6	3-5	3-4	3-3
	3-2	3-1	3-0	2-9	2-8	2-7	2-6
	2-5	2-4	2-3	2-2	2-1	2-0	1-9
	1-8	1-7	1-6	1-5	1-4	1-3	1-2
	1-1	1-0	0-9	0-8	0-7	0-6	0-5
	0-4	0-3	0-2	0-1	0-0		



INDUSTRIAL TRUCK DIVISION



NEW MACHINE 50 HOUR SERVICE AND INSPECTION

Air Cleaner, Service.....	8H 403
Battery Test and Level Check.....	100H 603
Brake Master Cylinder Level Check	100H 303
Brake Pedal, Adjust	100H 302
Cooling System, Inspect.....	100H 103
Cylinder Head, Tighten.....	1000H 003
Differential Level Check.....	100H 001
Engine Crankcase, Drain and Refill	100H 003
Engine Oil Filter, Change	100H 003
Fan Belt, Adjust	100H 203
Fuel Pump Strainer, Clean or Replace.....	500H 001
Hand Brake, Adjust.....	1000H 1103
Hydraulic Oil Filter, Change	500H 103
Hydratork Inching Cylinder Level Check	100H 304
Intake and Exhaust Manifold, Tighten	500H 403
Lift Chains, Adjust	100H 403
Lubricate Machine	100H 702
Nuts, Bolts and Capscrews, Tighten	500H 403
Pressure Check Main Hydraulic System	1000H 1503
Steering Gear Level Check	100H 603
Transmission, Converter and Transfer Case Level Check	100H 001
Transmission, Converter and Transfer Case Change Filter....	500H 003

NOTE

PERFORM THIS SERVICE AND INSPECTION
AFTER THE FIRST 50 HOURS OF OPERA-
TION ON NEW MACHINES.

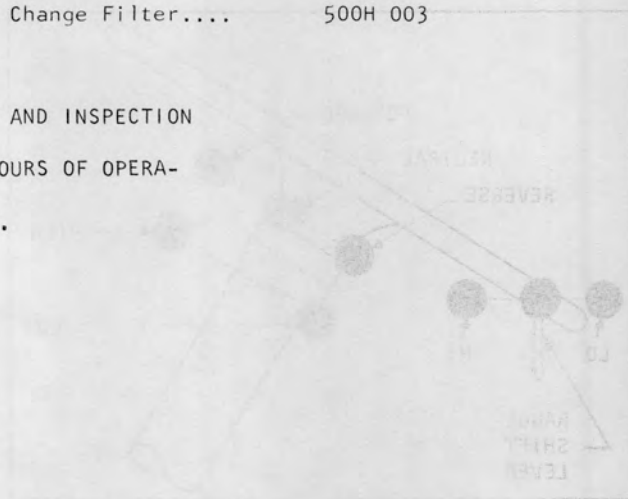

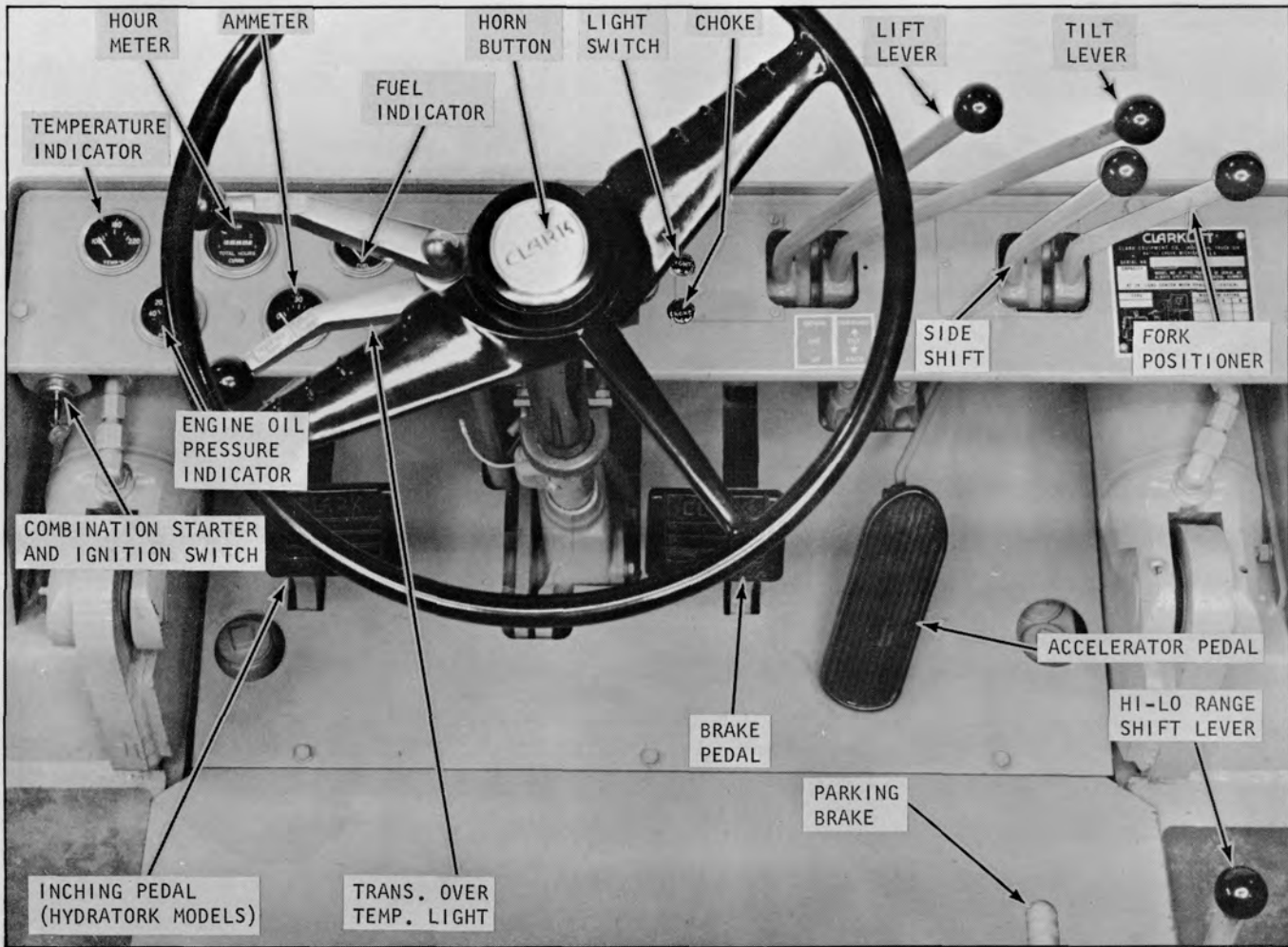

Plate 8657. Overall Controls

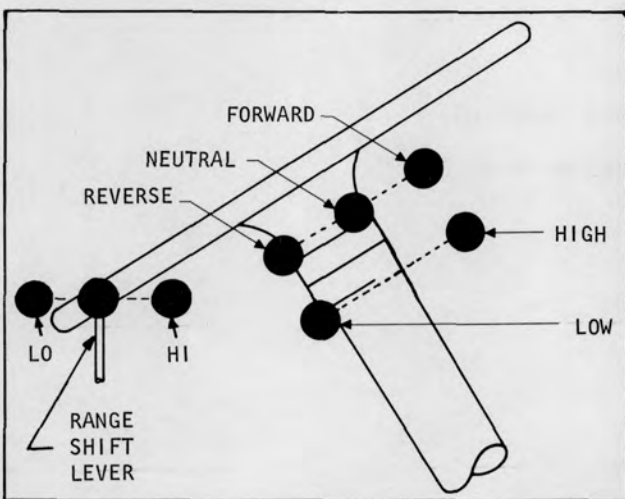

Plate 8656. Shift Pattern
(HYDRATORK MODELS)



Plate 6417. Oil Pressure Indicator



Plate 7647. Ammeter

INSTRUMENT INDICATORS

a. Oil Pressure Indicator. Oil pressure should be at least 7 pounds at idle (400 to 600 R.P.M.) CAUTION: IF THE OIL PRESSURE IS ERRATIC OR FALLS BELOW THE ABOVE LIMIT, STOP THE ENGINE IMMEDIATELY AND FIND THE CAUSE OF THE TROUBLE. REFER TO TROUBLE SHOOTING SECTION FOR THIS INFORMATION.

CAUTION

ON NEW MACHINES, AFTER STARTING ENGINE -- RUN IT AT IDLE FOR 5 MINUTES, THEN STOP ENGINE AND RECHECK OIL LEVEL IN CRANKCASE - BRING OIL LEVEL TO HIGH MARK, IF NECESSARY.

c. Ammeter. The ammeter is connected in the generator (or alternator if used) and battery circuit in such a manner as to indicate rate of charge or discharge. If the generator (or alternator) is functioning properly the ammeter should show a small amount of charge at engine idle. As engine R.P.M. increases the rate of charge also increases. When the battery becomes fully charged the circuit is regulated to reduce the rate of charge, and cause the ammeter needle to return to near neutral position, showing only a small amount of charge.

NOTE

BEFORE PLACING MACHINE IN OPERATION RUN ENGINE A FEW MINUTES TO WARM OIL, ESPECIALLY IN COLD OPERATING CONDITIONS.

NOTE

DIESEL ENGINE MODELS

REFER TO ENGINE OPERATORS MANUAL

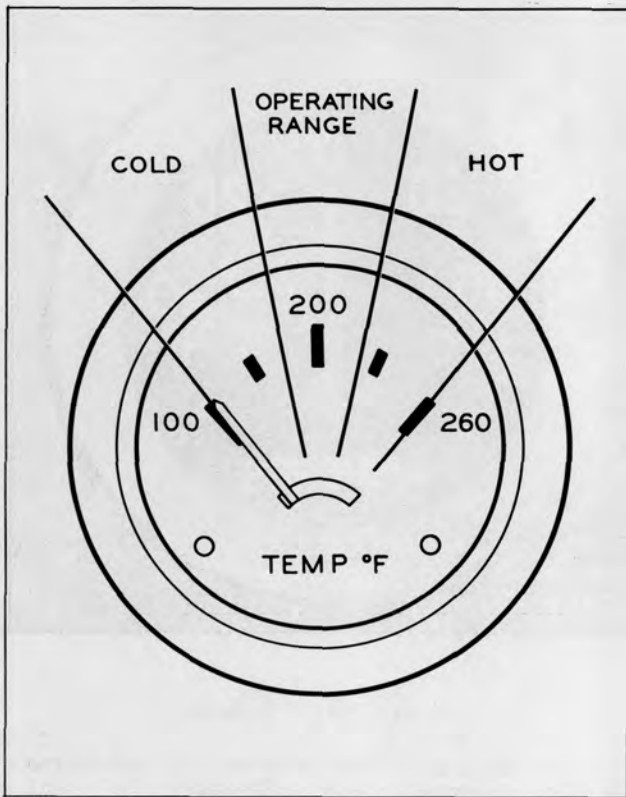

Plate 8288. Engine Coolant Temperature Indicator

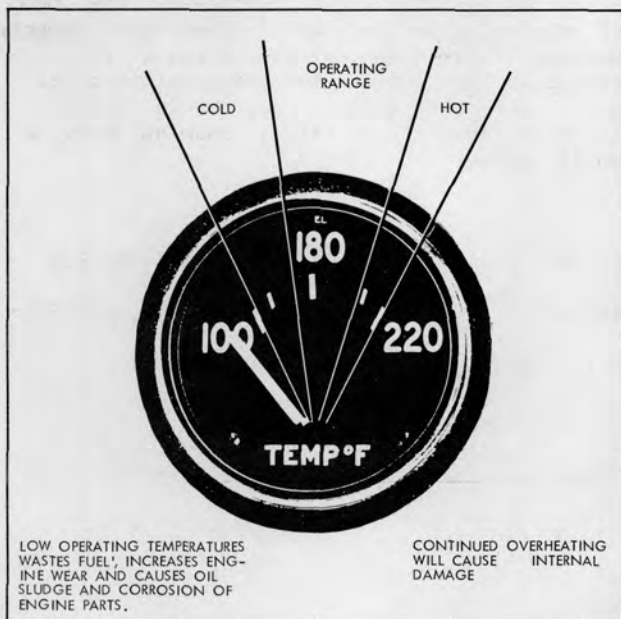

Plate 6287. Engine Coolant Temperature Indicator



Plate 7162. Hour Meter

The hour meter accurately records the actual hours of machine operation. This will serve as an aid in determining the time intervals for lubrication and preventive maintenance services.

NOTE

The coolant temperature should register in the operating range after the first few minutes of operation. Low operating temperatures wastes fuel and increases engine wear.

CAUTION

DO NOT IDLE THE ENGINE FOR LONG PERIODS AS IT IS NOT ONLY DETRIMENTAL TO THE ENGINE BUT ALSO INCREASES OPERATING COSTS AS YOU ARE USING FUEL WITHOUT BENEFIT.

NOTE

Select the indicator in your machine. Coolant temperatures should read as marked, except for diesel equipped machines.

DIESEL MACHINES: REFER TO DIESEL OPERATORS MANUAL FOR COOLANT TEMPERATURES.



Plate 6418. Ignition Switch

STARTING

Place all transmission control levers in neutral position. Pull out on choke and engage the starter by actuating the ignition switch in the start position.

CAUTION

DO NOT ENGAGE THE STARTER LONGER THAN 15 SECONDS WITHOUT A MINUTE OR SO INTERVAL BETWEEN TRIALS.

If the engine becomes overchoked or flooded; push choke button in, depress accelerator pedal fully and engage starter. If all necessary equipment is in correct working order, the engine will start.

After engine has started, check instrument panel making certain the engine oil pressure indicator shows adequate pressure. If no oil pressure is indicated, stop engine and correct the difficulty.

NOTE

RUN ENGINE A FEW MINUTES TO WARM OIL, BEFORE PUTTING MACHINE TO WORK ESPECIALLY IN COLD OPERATING CONDITIONS.

TO OPERATE MACHINE

1. Place Transmission control levers in neutral position and start engine.
2. Move Hi and Lo range lever for desired speed.
3. Now move forward and reverse lever out of neutral and into position for desired direction. Accelerate as required.
4. Inching Operation: To inch the machine into a load, the brake pedal should be depressed in its free travel range and the accelerator pedal actuated as required. The initial brake movement is used to regulate the inching control valve which allows a decrease in pressure on the transmission selector pack discs. This permits controlled slippage of the discs allowing the machine to inch - - - after the brake pedal travel has actuated the inching valve mechanism the brake become applied and all pressure by-passes the selector discs.

CAUTION

TO PROLONG MACHINE LIFE IT IS BEST TO COME TO A COMPLETE STOP BEFORE SHIFTING TO THE OPPOSITE DIRECTION.

ALLOW FOOT TO REST ON BRAKE PEDAL ONLY WHEN INCHING IS DESIRED. DO NOT ALLOW FOOT TO REST ON BRAKE PEDAL WHILE DRIVING MACHINE FROM POINT TO POINT. RIDING THE BRAKE PEDAL WILL CAUSE CONTINUED SLIPPAGE OF THE TRANSMISSION SELECTOR PACKS RESULTING IN OVERHEATING AND UNNECESSARY WEAR OR DAMAGE TO TRANSMISSION COMPONENTS.

TO STOP MACHINE

Remove foot from accelerator pedal and depress brake pedal. If machine is to be parked, place transmission control levers in neutral position, apply hand brake and shut engine off.

CAUTION

IF THE ENGINE HAS BEEN OPERATING AT OR NEAR FULL LOAD, IT SHOULD BE ALLOWED TO RUN AT FAST IDLE (600 to 800 R.P.M.) FOR ONE OR TWO MINUTES AFTER LOAD IS REMOVED BEFORE BEING STOPPED. THIS ALLOWS INTERNAL ENGINE TEMPERATURES TO EQUALIZE.



INDUSTRIAL TRUCK DIVISION



OPERATIONS

TO MOVE A LOAD

The forks should be adjusted sidewise on fork bars to obtain maximum balance in proportion to width of load. Raise or lower forks to proper level and center the load as nearly as possible on the forks. Tilt upright assembly slightly backward to prevent the load from falling, accelerating engine slightly at the same time. Back away from stack.

Adjust the forks with load so they are close to the floor or ground but high enough to avoid hitting obstructions. The operator should have clear vision ahead when moving in a forward direction. When this is not possible, the operator should drive in reverse and sufficiently turn in his seat to obtain clear vision backward.

When the load is to be deposited, enter the area squarely, especially when placing one load on top of another, in order that all piles will be square and secure. Place load directly over desired area and slowly lower to the floor.

IMPORTANT

EVERY 8 OPERATING HOURS (OR EVERY SHIFT) ELEVATE UPRIGHT TO THE UPPER LIMIT. THIS WILL PROVIDE LUBRICATION TO THE TOP PORTION OF THE LIFT CYLINDER.

SAFETY AND OPERATION SUGGESTIONS

The use of industrial powered trucks is subject to certain hazards that cannot be overcome by purely mechanical means. The exercise of intelligence, care and common sense by the truck operator is necessary to eliminate the hazards of overloading, slipping and falling of the load; obstructions in the path of travel, or the use of equipment for a purpose for which it is not intended or designed.

The following are a few suggestions that should be followed in the operation of this machine.

1. Operate machine with forks close to floor, loaded or empty, but high enough to avoid hitting obstructions.
2. If vision is obstructed by the load, operate machine in reverse and sufficiently turn in the seat to obtain clear vision.

3. Avoid sudden stops or starts. When backing, be sure to look for fellow workmen before moving machine.
4. Drive carefully at all times. Exercise caution at cross aisles. Sound horn for safety.
5. Be sure loads are safe to move. Have loads properly centered on machine. Refer to the Capacity Chart in Specifications for various load center ratings.
6. An operator should be assigned to a specific machine.
7. The operator should be qualified and drive in accordance with his company's safety rules.
8. If the machine does not respond immediately, report to designated individual in charge. A minor adjustment now may save a major repair later.
9. Do not allow riders or hitchhikers.
10. Operate the machine at a safe distance behind other vehicles.
11. Do not operate machine with wet or greasy hands.
12. Observe highway traffic laws in the operation of the vehicle in the plant.
13. Drive carefully on wet or slippery floors.
14. Keep feet within running line of truck.
15. Observe the Operating Rules and Preventive Maintenance Instructions ASA B56.1 Safety Code for Powered Industrial Trucks.
16. Avoid overloading the truck -- this is a safety measure against possible injury to the driver and fellow workmen. Overloading shortens the life of the truck and increases maintenance.
17. Do not operate machine for prolonged periods in an unventilated area. All engines produce poisonous carbon monoxide gas as a by-product of combustion and can be dangerous if allowed to accumulate in a closed area.
18. Be sure the brakes are in proper working condition. Be sure all mechanical and electrical components are working correctly.

INDUSTRIAL TRUCK DIVISION

MEMORANDUM

Faint, illegible text on the left side of the page, possibly bleed-through from the reverse side.

Faint, illegible text on the right side of the page, possibly bleed-through from the reverse side.



INDUSTRIAL TRUCK DIVISION



LUBRICATION AND PREVENTIVE MAINTENANCE INDEX

	Time Interval (H=Hours)	Page Number (0000-)		Time Interval (H=Hours)	Page Number (0000-)
<u>(8 HOURS)</u>					
Air Cleaner Service	8H	403	Lift Brackets, inspect.....	100H	503
Brake Pedal Operation	8H	303	Lift Chain, Adjust.....	100H	403
Brake Operation, Parking...	8H	303	Lubrication Chart	100H	702
Crankcase Oil Level Check..	8H	003	Steer Gear Level Check	100H	603
Engine Cooling System Check.	8H	103	Transmission & Transfer Case Level Check.....	100H	101
Engine Coolant Temperature Indicator.....	8H	203	<u>(500 HOURS)</u>		
Fuel Tank Check	8H	001	Fuel Pump	500H	001
Horn.....	8H	001	Fuel Pump Strainer	500H	001
Horn Fuse	8H	001	Hydraulic Oil Filter change..	500H	103
Hydraulic Control Levers....	8H	503	Intake and Exhaust Manifold..	500H	403
Hydraulic Sump Tank Level check.....	8H	503	Nuts, Bolts & Capscrews, Tighten.....	500H	000
Ignition Fuse	8H	001	Steering Axle & Linkage adjustment.....	500H	302
Oil Pressure Indicator	8H	203	Steering Gear Adjustment	500H	202
Tire & Rim Maintenance	8H	602	Transmission & Converter Filter	500H	003
<u>(100 HOURS)</u>			Transmission, Converter and Transfer Case Drain & Refill.	500H	003
Battery Electrolyte Level and Test	100H	603	Universal Joints inspect.....	500H	403
Brake Master Cylinder Level Check	100H	303	<u>(1000 HOURS)</u>		
Brake Pedal Adjust	100H	302	Drive Wheel Bearings clean, inspect & repack.....	1000H	805
Cooling System.....	100H	103	Brakes Adjust.....	1000H	1003
Differential Level Check...	100H	001	Brake System; test and bleed.	1000H	913
Engine Breather	100H	003	Carburetor, adjust.....	1000H	403
Engine Crankcase	100H	003	Compression test, Engine	1000H	103
Engine Oil Filter	100H	003	Cooling System, inspect & clean	1000H	1202
Fan Belt, adjust	100H	203	Crankcase Ventilation	1000H	003
Fuel Tank and Lines	100H	001	Cylinder Head Tightening Sequence	1000H	003
Hydraulic Sump Tank Breather.....	100H	503	Differential, drain & refill.	1000H	1304
Hydraulic System inspect...	100H	403	Distributor, Inspect & adjust	1000H	203
Inching Cylinder Level check.....	100H	304			



INDUSTRIAL TRUCK DIVISION



LUBRICATION AND PREVENTIVE MAINTENANCE INDEX

(1000 HOURS cont'd)	Time Interval (H=Hours)	Page Number (0000-1)	Description	Time Interval (H=Hours)	Page Number (0000-)
Engine Tune-Up.....	1000H	001	Plate Lube. & Prev. Main. 7706 illus.	8H	000
Generator, inspect.....	1000H	703			
Governor, adjust	1000H	503	Plate Lube. & Prev. Main. 7707 illus.	100H	000
Hydratork Inching Cylinder, bleed	1000H	914	Lube. Instruction Diagram	100H	702
Hydraulic Sump Tank, drain and refill	1000H	1403	Plate Lube. & Prev. Main. 7708 illus.	500H	000
Hand Brake, adjust	1000H	1103	Plate Lube. & Prev. Main. 7709 illus.	1000H	000
Intake and Exhaust Valve Clearance, adjust	1000H	303			
Ignition Timing	1000H	303			
Neutral Starting Switch ..	1000H	1793			
Pressure checks (Main Hydraulic System).....	1000H	1503			
Transmission Stall and Pressure checks	1000H	1703			
Spark Plugs, clean & adjust	1000H	103			
Starter, inspect	1000H	603			
Steer Wheel Bearings, clean, inspect & adjust	1000H	803			
Upright & Lift Carriage Roller Adjustment	1000H	1803			
Voltage Regulator, inspect.	1000H	704			
Wiring, inspect	1000H	704			

NOTE

WHEN PERFORMING THE 100, 500 OR 1000 HOUR
LUBRICATION AND PREVENTIVE MAINTENANCE,
ALWAYS INCLUDE THE PREVIOUS LUBRICATION
AND PREVENTIVE MAINTENANCE SCHEDULES.



INDUSTRIAL TRUCK DIVISION



LIBRARY AND DOCUMENTATION CENTER

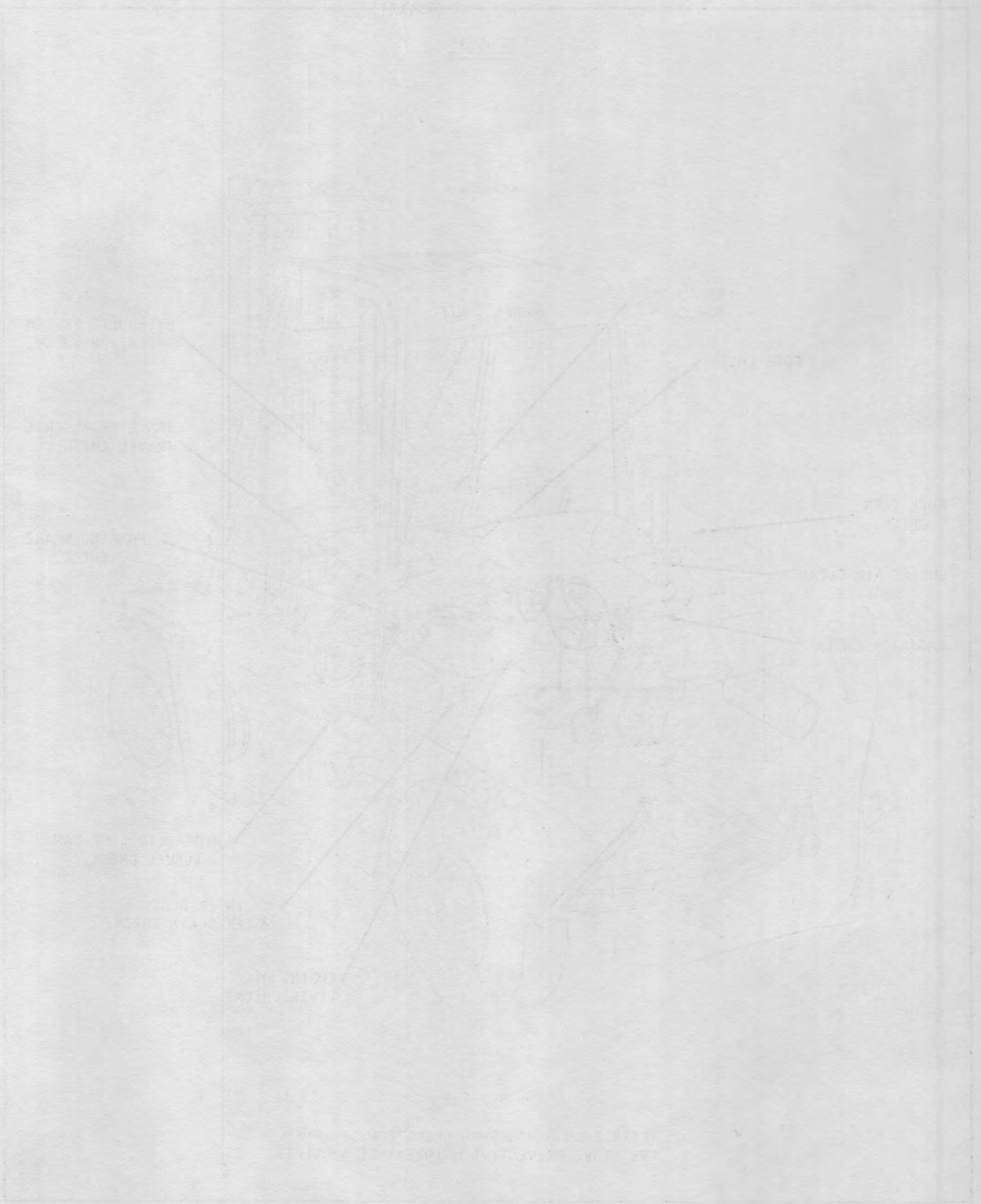

INDUSTRIAL TRUCK DIVISION

LIBRARY AND DOCUMENTATION CENTER

8 HOURS

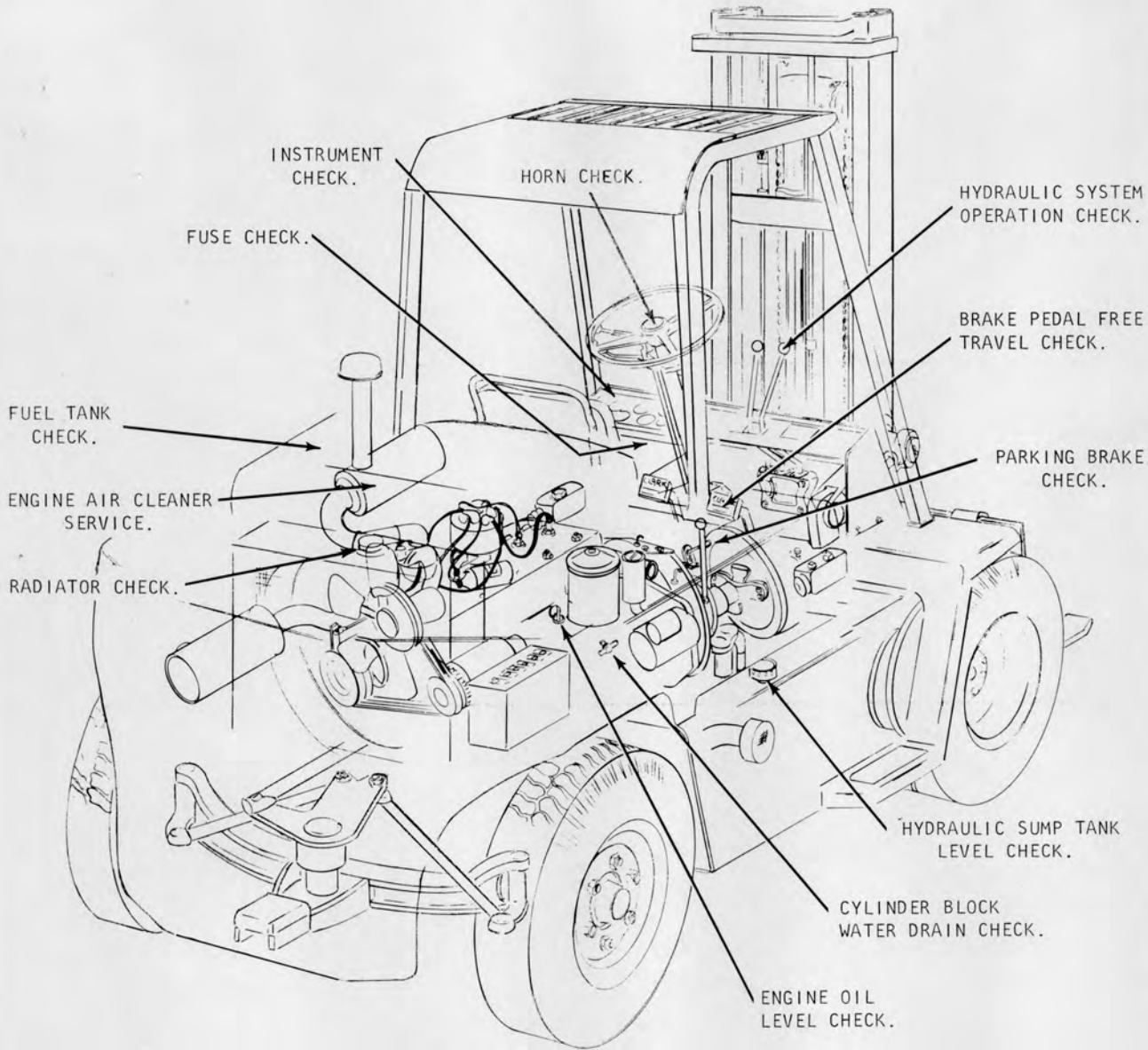

N O T E

AFTER EACH 8 HOURS OF OPERATION, PERFORM
THE ABOVE PREVENTIVE MAINTENANCE SERVICES.

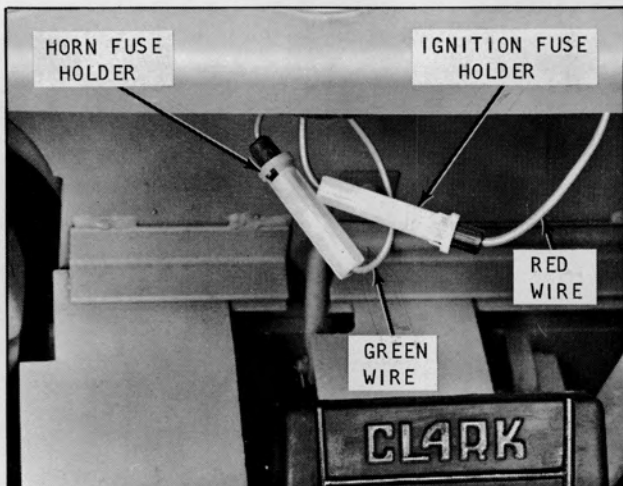

Plate 7648. Horn and Ignition Fuse

HORN

Check to be sure the horn is working properly.

FUSES

Check the electrical circuit fuses. The fuse holders are located beneath the dash. A red wire leads to the ignition fuse holder and a green wire leads to the horn fuse holder.

FUEL TANK

Check fuel supply and fill if necessary. Use a good grade of fuel.

Before filling fuel tank, make certain the filler cap screen is in place and not damaged (on machines so equipped).

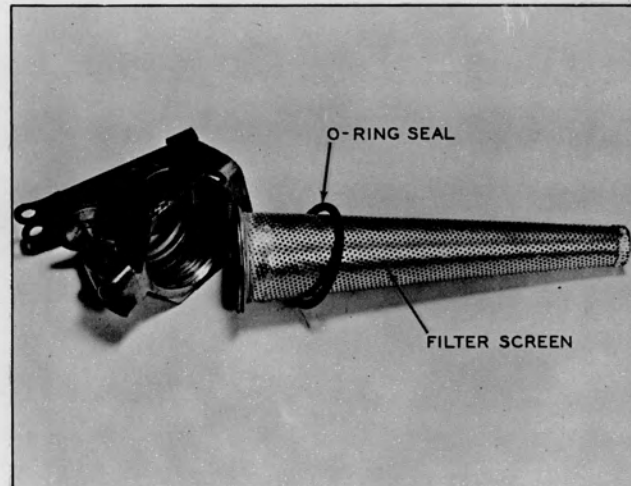

Plate 6627. Gasoline Tank Filler Cap and Screen

WARNING

DO NOT FILL THE TANK WITH THE FILLER CAP SCREEN REMOVED. (GASOLINE MODELS)

INDUSTRIAL TRUCK DIVISION

INSTRUCTIONS FOR DRIVER OF RAILTRUCK

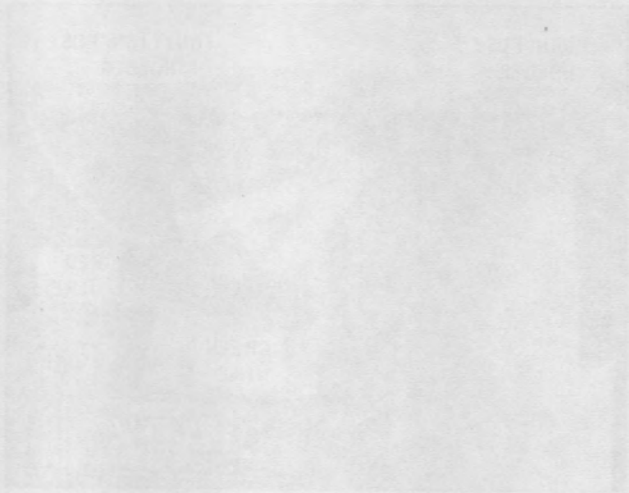
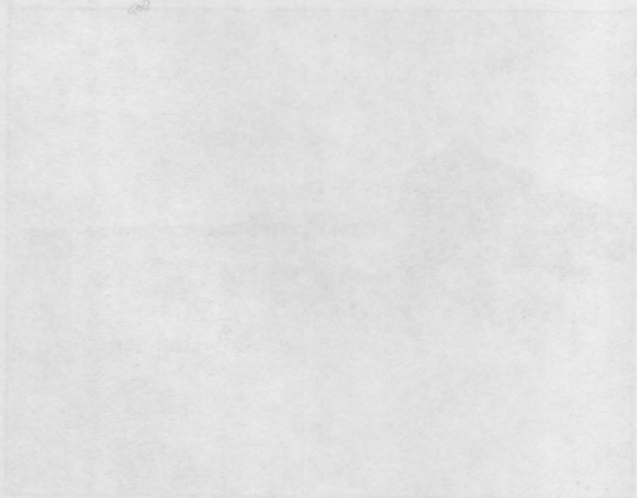

1. Start engine and run for 5 minutes before use.

2. Check oil level and adjust if necessary.

3. Check tire pressure and adjust if necessary.

4. Check brake fluid level and adjust if necessary.

5. Check water level in radiator and adjust if necessary.

6. Check battery charge and adjust if necessary.

7. Check all lights and signals and adjust if necessary.

8. Check all hoses and connections and adjust if necessary.

9. Check all fasteners and adjust if necessary.

10. Check all electrical connections and adjust if necessary.

11. Check all safety devices and adjust if necessary.

12. Check all other items and adjust if necessary.

13. Check all other items and adjust if necessary.

14. Check all other items and adjust if necessary.

15. Check all other items and adjust if necessary.

16. Check all other items and adjust if necessary.

17. Check all other items and adjust if necessary.

18. Check all other items and adjust if necessary.

19. Check all other items and adjust if necessary.

20. Check all other items and adjust if necessary.

21. Check all other items and adjust if necessary.

22. Check all other items and adjust if necessary.

23. Check all other items and adjust if necessary.

24. Check all other items and adjust if necessary.

25. Check all other items and adjust if necessary.

26. Check all other items and adjust if necessary.

27. Check all other items and adjust if necessary.

28. Check all other items and adjust if necessary.

ENGINE CRANKCASE (GAS MODELS)

Before attempting to start the engine, first make sure that it has sufficient oil. The oil filler pipe is located on the left side of the machine. The oil level stick is of the dipstick or bayonet type and is located on the right side of the machine. Fill the crankcase reservoir through the filler pipe to the proper level as indicated on the dipstick.

C A U T I O N

NEVER PERMIT THE OIL LEVEL TO FALL BELOW THE "ADD" MARK ON THE DIPSTICK. DO NOT OVERFILL THE CRANKCASE, AS TOO MUCH OIL WILL BRING THE LEVEL HIGH ENOUGH FOR THE CONNECTING RODS TO DIP, THUS CAUSING EXCESSIVE QUANTITIES OF OIL TO BE THROWN TO THE CYLINDER WALLS RESULTING IN OIL CONSUMPTION, SMOKING, EXCESSIVE CARBON DEPOSITS AND FOULED SPARK PLUGS.

N O T E

ON L.P. GAS ENGINES, USE A NON-DETERGENT OIL DURING BREAK-IN PERIOD.

Crankcase Capacity— Refer to Specifications For Service "MS"

SAE 10W	0°	to	32°	F.
SAE 20W	32°	to	75°	F.
SAE 30	... above		75°	F.

or use 10W-30 MULTI-GRADE OIL

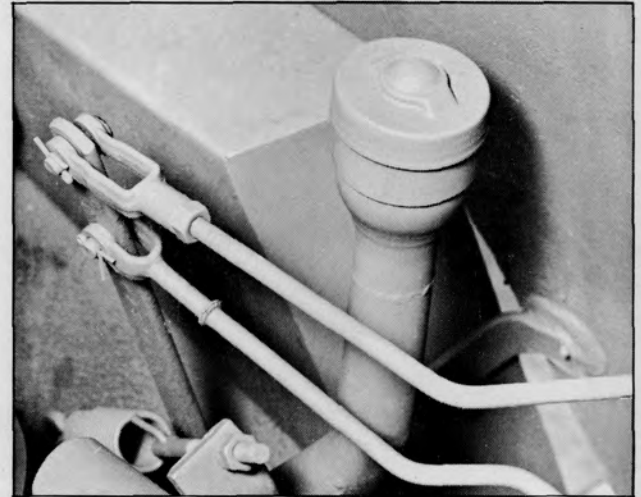

Plate 7649. Engine Crankcase Fill

N O T E

Diesel Engines: REFER TO DIESEL ENGINE OPERATORS MANUAL.

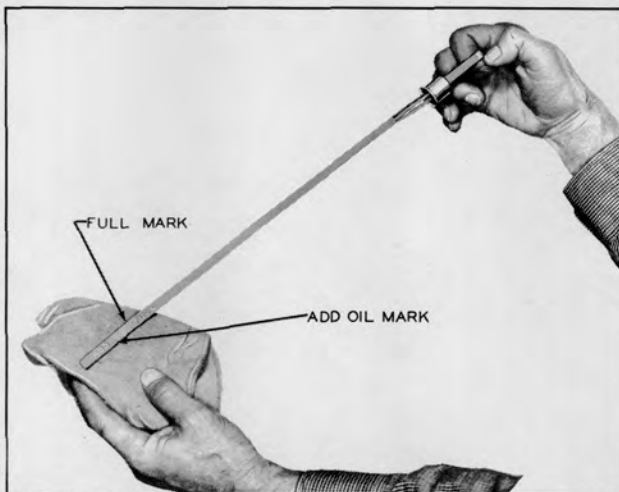
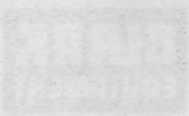

Plate 3145. Crankcase Oil Check

INDUSTRIAL TRUCK DIVISION



Faint, illegible text in the upper right quadrant of the page, possibly a title or introductory paragraph.

Main body of faint, illegible text in the center-right area of the page, likely the primary content of the document.



Faint text at the bottom left of the page, possibly a footer or concluding remarks.

Faint text at the bottom right of the page, possibly a footer or concluding remarks.

ENGINE COOLING

Make sure that the radiator drain cock and the water drain in the cylinder block are closed. Check radiator coolant level and fill to within 1 inch of the top with clean water; or if operation is in cold weather, use a suitable anti-freeze solution.

It is recommended that a soluble oil in the proportion of 1 ounce per gallon of water be added to the Cooling System.



Plate 7008. Cylinder Block Water Drain

CAUTION

NEVER POUR COLD WATER OR COLD ANTI-FREEZE INTO THE RADIATOR OF AN OVERHEATED ENGINE. ALLOW THE ENGINE TO COOL AND AVOID THE DANGER OF CRACKING THE CYLINDER HEAD OR BLOCK. KEEP ENGINE RUNNING WHILE ADDING WATER OR ANTI-FREEZE. WHEN PERMANENT ANTI-FREEZE OF THE ETHYLENE GLYCOL TYPE IS USED, THE COOLANT SOLUTION MUST CONTAIN AT LEAST 40% WATER.

NOTE

REFER TO DIESEL ENGINE MANUAL FOR MACHINES SO EQUIPPED.

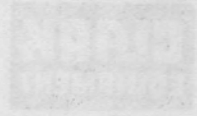

INDUSTRIAL TRUCK DIVISION

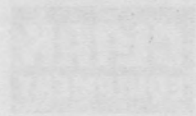

INDUSTRIAL TRUCK DIVISION

SECTION

INDUSTRIAL TRUCK DIVISION

POWER FROM YOUR MOTOR OR GAS ENGINE INTO
 THE ROTATION OF AN OVERSIZED DRIVE WHEEL
 THE CHAINS TO COOL AND AVOID THE RANGING OF
 GRINDING THE CYLINDER HEADS OR BECKING UP
 THE RUNNING WHILE ADDING WATER OR OIL
 WITH FORWARD AND REVERSE THE FORWARD
 BEYOND THESE LIMITS THE CONTACT WITH
 MUST CONTACT AT LEAST HOT WATER

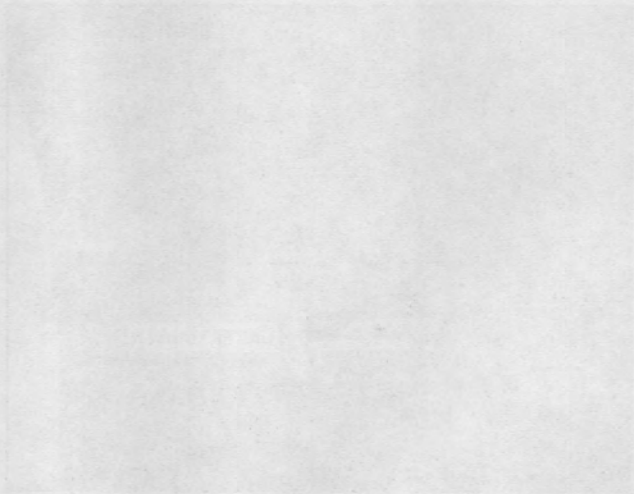

SEEK TO DIRECT ENGINEERS FOR PARTS SO
 EQUIPMENT

INDUSTRIAL TRUCK DIVISION



Plate 6417. Oil Pressure Indicator



Plate 7647. Ammeter

INSTRUMENT INDICATORS

a. Oil Pressure Indicator. Oil pressure should be at least 7 pounds at idle (400 to 600 R.P.M.) CAUTION: IF THE OIL PRESSURE IS ERRATIC OR FALLS BELOW THE ABOVE LIMIT, STOP THE ENGINE IMMEDIATELY AND FIND THE CAUSE OF THE TROUBLE. REFER TO TROUBLE SHOOTING SECTION FOR THIS INFORMATION.

CAUTION

ON NEW MACHINES, AFTER STARTING ENGINE -- RUN IT AT IDLE FOR 5 MINUTES, THEN STOP ENGINE AND RECHECK OIL LEVEL IN CRANKCASE - BRING OIL LEVEL TO HIGH MARK, IF NECESSARY.

c. Ammeter. The ammeter is connected in the generator (or alternator if used) and battery circuit in such a manner as to indicate rate of charge or discharge. If the generator (or alternator) is functioning properly the ammeter should show a small amount of charge at engine idle. As engine R.P.M. increases the rate of charge also increases. When the battery becomes fully charged the circuit is regulated to reduce the rate of charge, and cause the ammeter needle to return to near neutral position, showing only a small amount of charge.

NOTE

BEFORE PLACING MACHINE IN OPERATION RUN ENGINE A FEW MINUTES TO WARM OIL, ESPECIALLY IN COLD OPERATING CONDITIONS.

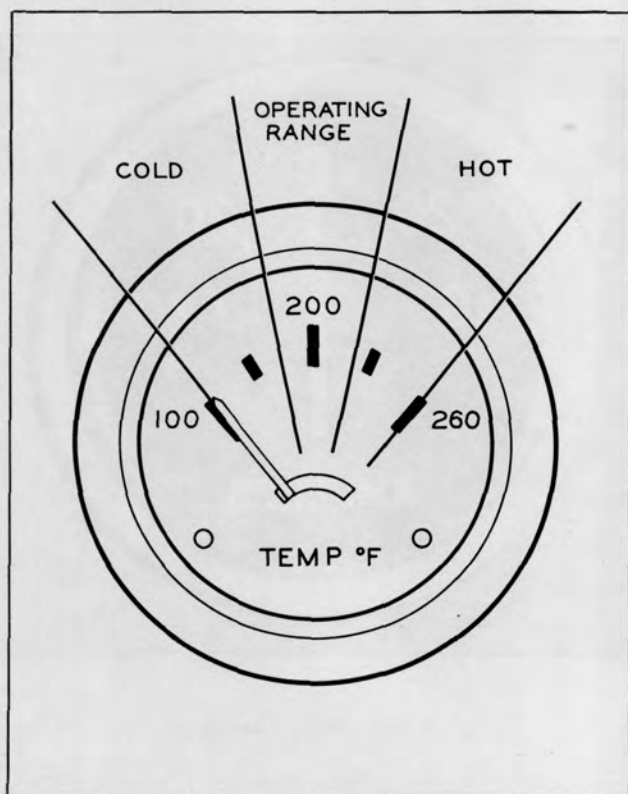

Plate 8288. Engine Coolant
Temperature Indicator

N O T E

THE COOLANT TEMPERATURE SHOULD REGISTER
180° to 220° F. AFTER THE FIRST TEN OR
FIFTEEN MINUTES OF OPERATION.

LOW OPERATING TEMPERATURES WASTES FUEL AND
INCREASES ENGINE WEAR.

C A U T I O N

DO NOT IDLE THE ENGINE FOR LONG PERIODS,
AS IT IS NOT ONLY DETRIMENTAL TO THE
ENGINE BUT ALSO INCREASES OPERATING COSTS
AS YOU ARE USING FUEL WITHOUT BENEFIT.



Plate 7162. Hour Meter

The hour meter accurately records the
actual hours of machine operation. This
will serve as an aid in determining the
time intervals for lubrication and preven-
tative maintenance services.

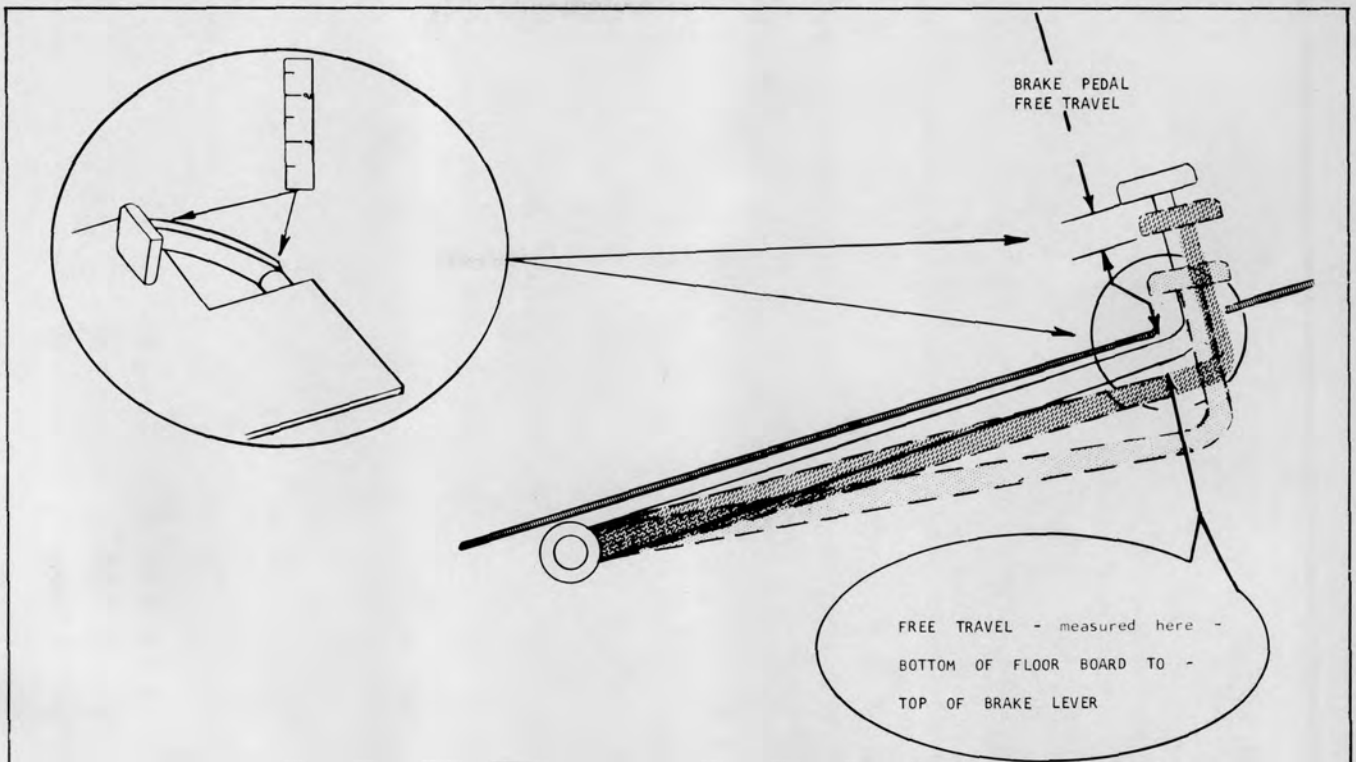

Plate 7042. Brake Pedal Free Travel

BRAKE PEDAL

1. Depress brake pedal and hold foot pressure for at least 10 seconds. Pedal must be solid, must not be spongy or drift under foot pressure. Pedal free travel should be 1/2 inch before meeting resistance from master cylinder piston.

PARKING BRAKE

Make certain that the parking brake is working properly. This shall be tested with the drivers seat occupied, the parking brake applied and the truck out of gear - Parking brake must be capable of holding the truck, with full rated load on a 15% grade.

If brake operation is not satisfactory, report to designated person in authority.



Plate 6505. Parking Brake

INDUSTRIAL TRUCK DIVISION

OPERATION AND MAINTENANCE MANUAL

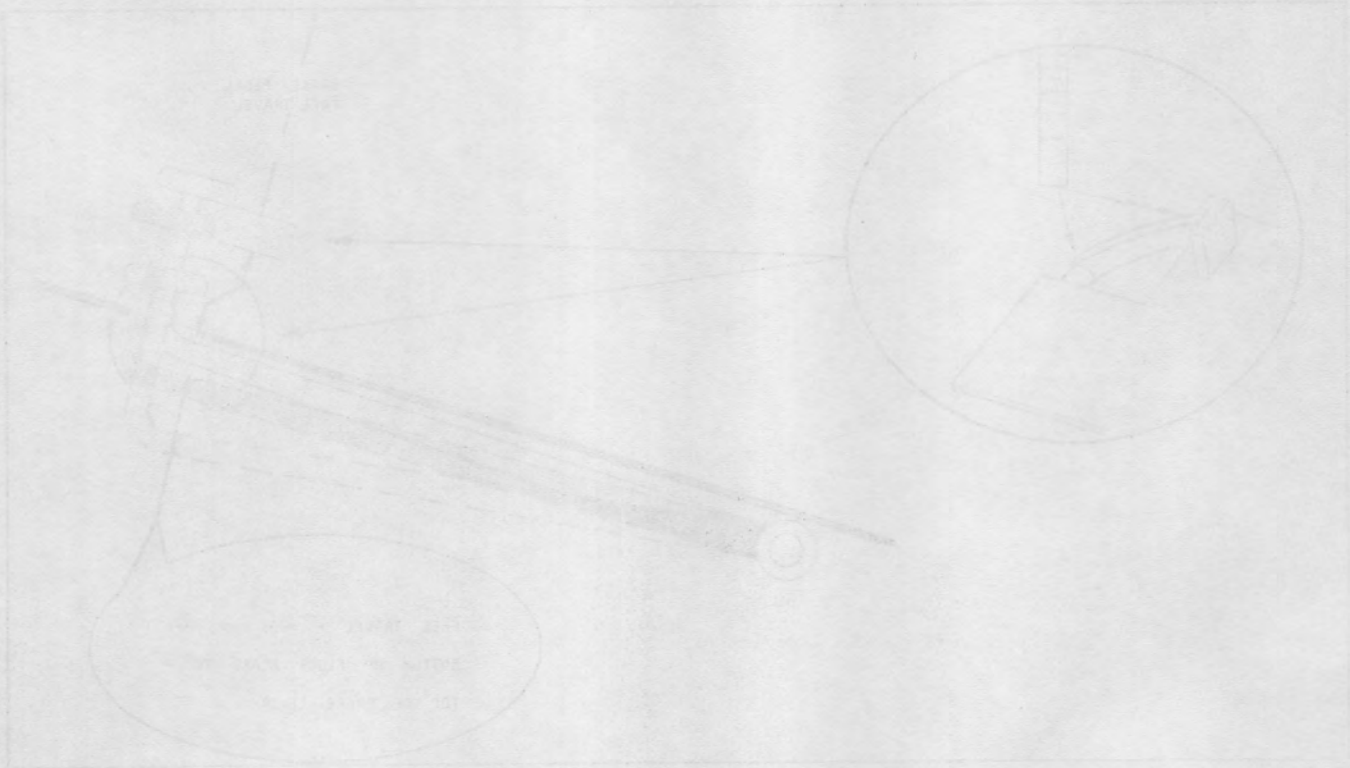
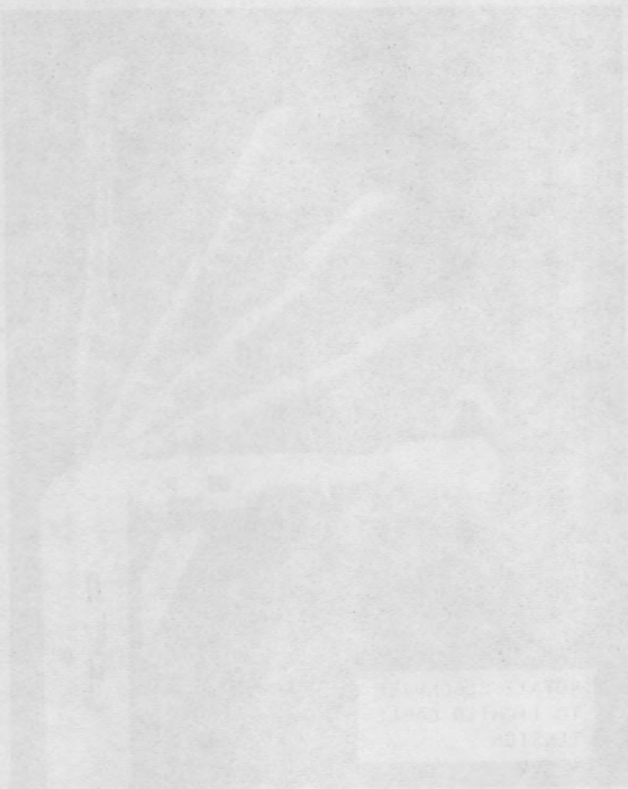

FIGURE 1: [Illegible text]



1. Downward stroke...
2. Upward stroke...
3. ...
4. ...
5. ...

6. ...
7. ...
8. ...
9. ...
10. ...

11. ...
12. ...

INDUSTRIAL TRUCK DIVISION
OPERATION AND MAINTENANCE MANUAL

AIR CLEANER (OIL BATH TYPE)

The air cleaner is of the oil bath type. The main function of the air cleaner is to prevent dirt and grit from getting into the engine. All engines, when operating, consume several thousand cubic feet of air per hour. Since dusty air is full of abrasive matter, the engine will soon wear excessively if the air cleaner does not remove the dust before entering the cylinders.

Operating conditions determine the air cleaner service periods. Under extremely dusty operations, this may be twice daily.



Plate 5985. Air Cleaner — Fill to oil level only

As the dirt is strained from the air flowing through the cleaner, it thickens the oil in the cup and raises the level. If the level is too high, agitation of the oil on the screen is affected and gritty oil is carried over into the air stream, through the carburetor and into the engine cylinders. This would actually introduce a grinding compound with resulting very rapid wear.

Proper servicing means cleaning thoroughly and refilling with new engine oil, and maintaining air-tight connections between the air cleaner and intake manifold so that all air entering the engine is filtered.

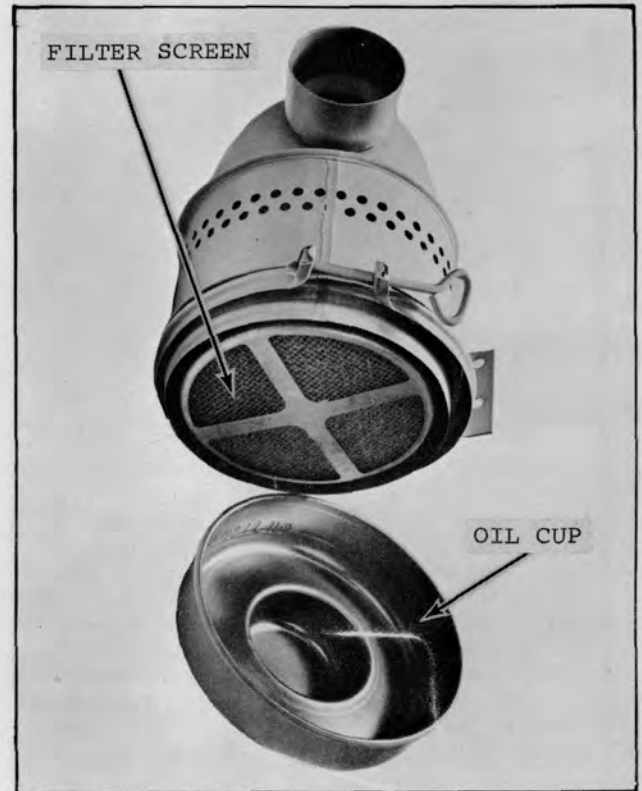

Plate 7663. Air Cleaner Screen and Oil Cup

RECOMMENDED MAINTENANCE

The air cleaner should be checked every 8 operating hours and cleaned if needed (this may be necessary twice daily under extreme dirty conditions).

Remove air cleaner oil cup and wash in a Stoddard type cleaning solvent. Wipe dry and refill with new engine oil. Replace oil cup on air cleaner being sure it is properly positioned.

Check all hose connections to be sure they are tight. Periodically remove hose connections and check interior of hose for dirt or dust. If found, this indicates that additional cleaning intervals are necessary.

Periodically (depending on operating conditions) every 100 operating hours, remove complete air cleaner assembly and



INDUSTRIAL TRUCK DIVISION



wash entire air cleaner internally. This is necessary as the unit is equipped with a built in screen. Soak the complete assembly in a Stoddard type cleaning solvent. Slop the assembly up and down being sure the solvent washes away any foreign matter that may be lodged in the screen. Wipe the exterior dry with a clean cloth and blow dry the interior with compressed moisture free air. Be sure cleaner assembly is absolutely dry before refilling oil cup to the proper level stamped on the cup. Avoid overfilling — capacity approximately $2\frac{1}{4}$ pints.

C A U T I O N

ALWAYS CHECK AIR CLEANER ASSEMBLY WITH THE ENGINE TURNED OFF. NEVER CHECK OR REFILL THE OIL CUP WITH THE ENGINE OPERATING.

Depending on the type of operation the machine is subjected to, determines the frequency in which the air cleaner should be serviced. However, regardless of the type operation, the air cleaner should be checked every 8 operating hours and the necessary maintenance performed as explained in the preceding paragraphs. Haphazard maintenance will lead to short engine life. Air cleaner maintenance may seem trivial, but it can mean longer engine life, less engine up keep and better economy providing proper maintenance is exercised. Common sense with a close observance can best determine the frequency of air cleaner maintenance.

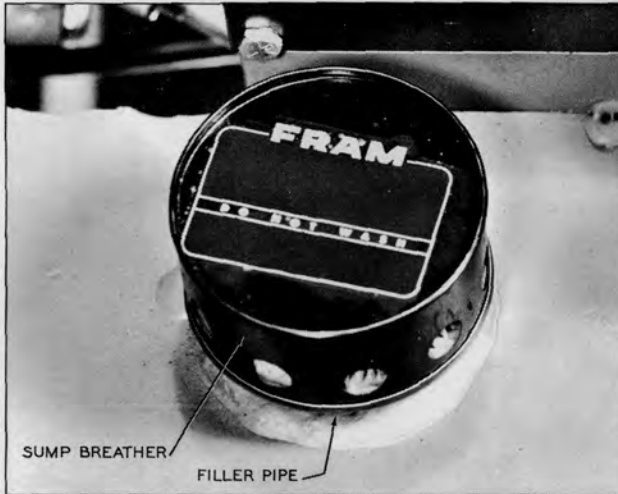

Plate 6626. Hydraulic Sump Tank and Sump Breather

HYDRAULIC SUMP TANK

Check hydraulic sump tank fluid level in the following manner:

1. Lower upright.
2. Turn switch key to off position.
3. Remove sump breather. Fluid level should be up to bottom of filler pipe.

If necessary, fill sump tank using MS 68 Hydraulic fluid. Move valve control levers with hydraulic pump operating to allow any air in the lines to escape, then recheck sump tank fluid level and fill as required before putting machine in operation.

HYDRAULIC CONTROL LEVERS

I M P O R T A N T

EVERY 8 OPERATING HOURS (OR EVERY SHIFT)

ELEVATE UPRIGHT TO THE UPPER LIMIT. THIS WILL PROVIDE LUBRICATION TO THE TOP PORTION OF THE LIFT CYLINDER.

Check lift and tilt operation. The lift and tilt cylinders should actuate when lift or tilt levers are moved either way from neutral position.

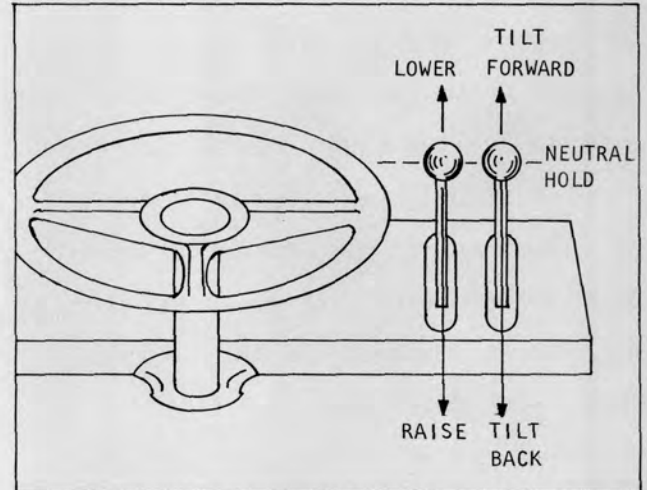

Plate 7305. Lift and Tilt Levers

When load is elevated and control lever returned to neutral position, load should remain in elevated position with no noticeable downward drift. If load drifts downward excessively, this may indicate lift cylinder U-Cup or seal damage -- report to designated person in authority.

With tilt lever in neutral position, upright should remain steady with no noticeable backward or forward drift. If upright drifts excessively either way, this may indicate tilt cylinder seal or U-Cup damage -- report to designated person in authority.

C A U T I O N

NEVER ALLOW LOADED OR UNLOADED LIFT CARRIAGE TO REMAIN IN AN ELEVATED POSITION FOR ANY PROLONGED PERIODS. LIFT CARRIAGE SHOULD BE LOWERED WHEN NOT IN USE.

DO NOT HOLD CONTROL LEVERS IN EXTREME POSITIONS AFTER A LOAD HAS REACHED ITS LIMITS. TO DO SO WILL RESULT IN HIGH OIL PRESSURE THAT MAY RESULT IN HEATING OF THE HYDRAULIC OIL.

TIRE AND RIM MAINTENANCE

WARNING

AN INFLATED TIRE AND RIM CAN BE VERY DANGEROUS. MANY ACCIDENTS, SOME FATAL, HAVE RESULTED FROM IMPROPER HANDLING AND OPERATION OF VEHICLE RIMS TIRES AND WHEELS. IT IS, THEREFORE, OF THE UTMOST IMPORTANCE THAT THE FOLLOWING PRECAUTIONS BE NOTED BY ALL PERSONS CONCERNED TO AVOID PERSONAL INJURY AND COSTLY DAMAGE.

1. After raising the vehicle and prior to removal of wheels, place blocking under the frame so the vehicle cannot become lowered by accident. Blocking must be of adequate strength to support the weight of the vehicle.

2. Some vehicles use a rim that has a inner half and a outer half. The two halves are held together by bolts and by the wheel attaching bolts. See Plate 7613. In all cases the air should be removed from the tire by removing the valve core before attempting to remove the wheel from the vehicle. The tire should not be inflated while it is "off" the vehicle. Check for security of all rim retainment bolts and wheel attaching bolts before

inflating tire. A clip-on type air chuck should be used so the operator can stand to one side during tire inflation.

3. In all cases, when removing wheels equipped with the lock ring type rim from the vehicle for repair or periodic rotation, completely deflate tires. This is best accomplished by removing the valve core.

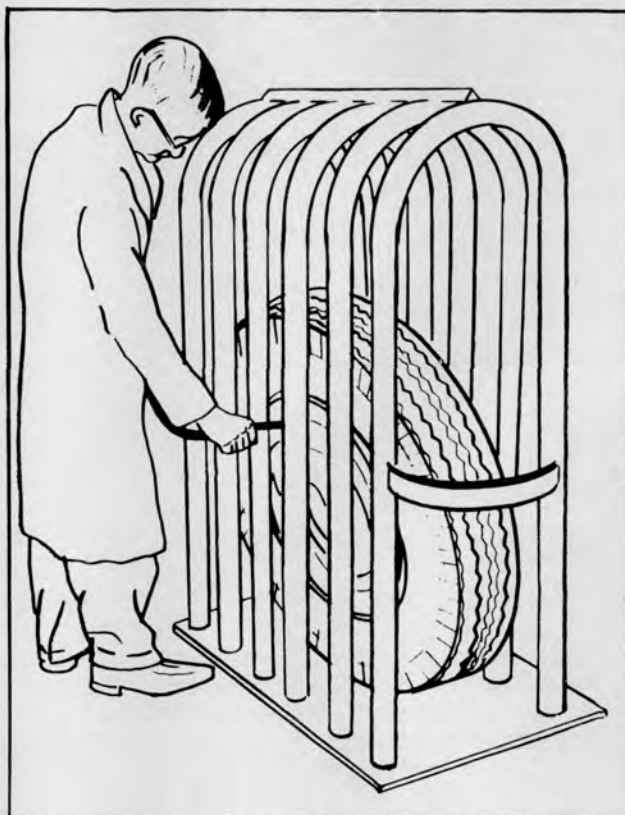

Plate 7614. Typical Safety Cage

4. Tires used on the lock ring type rim should be inflated in a safety cage. See Plate 7614. Insure that rings are properly seated prior to inflation. An inflated tire contains potentially explosive energy that can blow rings loose. A clip-on type air chuck should also be used, so the operator can stand to one side during tire inflation.

5. Use properly matched parts only. Rim base and rings must be matched according to manufacturer, size and type. This information is stamped on each part.

6. Remove rust and other foreign matter. Accumulation of such material in the rim gutter can prevent the proper fitting of rings. Parts that are excessively corroded are weakened and should be replaced. Use



Plate 7613. Typical Wheel with Inner and Outer Halves



INDUSTRIAL TRUCK DIVISION



TIRE AND RIM MAINTENANCE

of a rust preventative compound (not containing water) during mounting will minimize rusting.

7. Do not use over-size or over-inflated tires. Use only preferred or alternate size rims for tires and do not exceed recommended air pressures. It is also important to maintain uniform inflation in both tires of a dual assembly so that weight is equally sustained.

8. Do not run vehicle on one tire of a dual assembly. Never re-inflate a tire that has been run flat without first thoroughly inspecting it and the rim assembly. It is especially important to make sure the lock ring is secure in the gutter and has not been damaged prior to re-inflation.

9. Completely deflate tire prior to demounting. Remove valve core to insure complete deflation. Check for damage or worn parts. Mark defective parts for destruction to preclude their future use. Abuse during operation or in mounting the tire can cause dents, cracks or distortions which weaken the parts and prevent safe, proper assembly. Replace defective parts with new parts of the correct size and type.

10. Periodically check clamps and wheel nuts. Loose clamps can cause dangerous rim slippage or detachment of rim and tire from the vehicle. Loose wheel nuts can cause severe damage to rim and hub. Excessive torque is also dangerous in that it can cause stud and rim breakage.

11. Even with the best of maintenance practices, cuts will still be a source of tire trouble. The correct procedure for handling and repairing tires should be given careful attention. Close inspection of all tires should be made at the time of inflation check, and all tires having cuts that penetrate into the cord body should be taken off for proper repair.

Failure to make regular inspections and repairs, when needed, will result in further deterioration of the cord body and eventually a blowout. Small rocks and dirt will get into shallow cuts in the tread and if neglected will gradually be pounded through the cord body.

One simple method to forestall this action is to clean out the cut with an Awl or similar tool to remove any stones or other matter which may be lodged in the cut. Use a sharp, narrow-bladed knife and cut away the rubber around the cut to form a cone-shaped cavity extending to the bottom of the injury. The sides of the cavity should be slanted enough to prevent stones from wedging into it. Tires with cuts treated in this manner may be continued in service without danger of further growth of these injuries. If a tire has at least one deep cut that requires a repair, then all smaller cuts may be quickly and economically repaired and vulcanized by the steam kettle method.

NOTE

IT IS NOT RECOMMENDED THAT TIRES WITH BREAKS BE USED AGAIN.

If uneven tire wear is evident, wheel alignment should be checked.

DIRECTIONAL TREAD TIRES

All directional tread tires are to be mounted in the correct position with respect to the arrow cast on the side of the tire as explained and illustrated below.

Directional Tread Dual Tires:

1. Inside dual tire arrow to point in the direction of forward rotation, see Plate 6422.

(Rotate wheel to bring arrow on tire above the wheel. Arrow must point toward front of truck.)

2. Outside dual tire arrow to point in the direction of rearward rotation, see Plate 6423.

(Rotate wheel to bring arrow on tire above the wheel. Arrow must point toward rear of truck.)

Directional Tread Single Drive Tires:

1. Tire arrow to point in the direction of forward rotation, see Plate 6422.

(Rotate wheel to bring arrow on tire above the wheel. Arrow must point toward front of truck, see Plate 6422.)

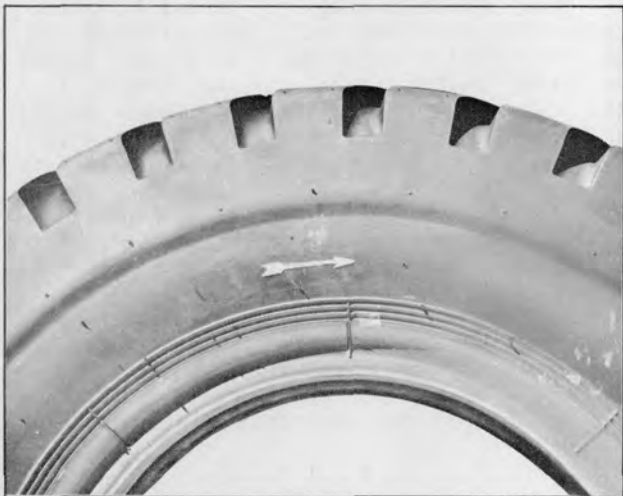

Plate 6422. Inside Dual Tire
(or Single Drive Tire)
(Arrow to point toward front of truck)

Plate 6423. Outside Dual Tire
(Arrow to point toward rear of truck)

SOLID OR CUSHION TIRE AND RIM MAINTENANCE

1. Inspect tires regularly - remove all sharp objects picked up by treads before they have a chance to cut further into the rubber and cause chipping or possible separation of the rubber from the base metal.
2. Avoid overloading and do not allow vehicle to stand under heavy loads for prolonged periods as this will cause a "flat" spot on the tires.
3. Check steering axle alignment regularly to protect against fast, irregular tread wear and separation.
4. If rubber tires come in contact with oils, grease, and gasoline they should be wiped off without delay.
5. Regular lubrication of all wheel bearings will assure free-rolling and elimination of tire drag when stopping or starting.

INDUSTRIAL TRUCK DIVISION



100 HOURS

LUBRICATE MACHINE

LIFT CHAINS INSPECT,
LUBRICATE & ADJUST.
USE CHAIN LUBE CLARK
NUMBER 886399. NOTE:
WHEN OPERATING IN
ABRASIVE ATMOSPHERE,
KEEP LIFT CHAINS FREE
OF LUBRICANT.

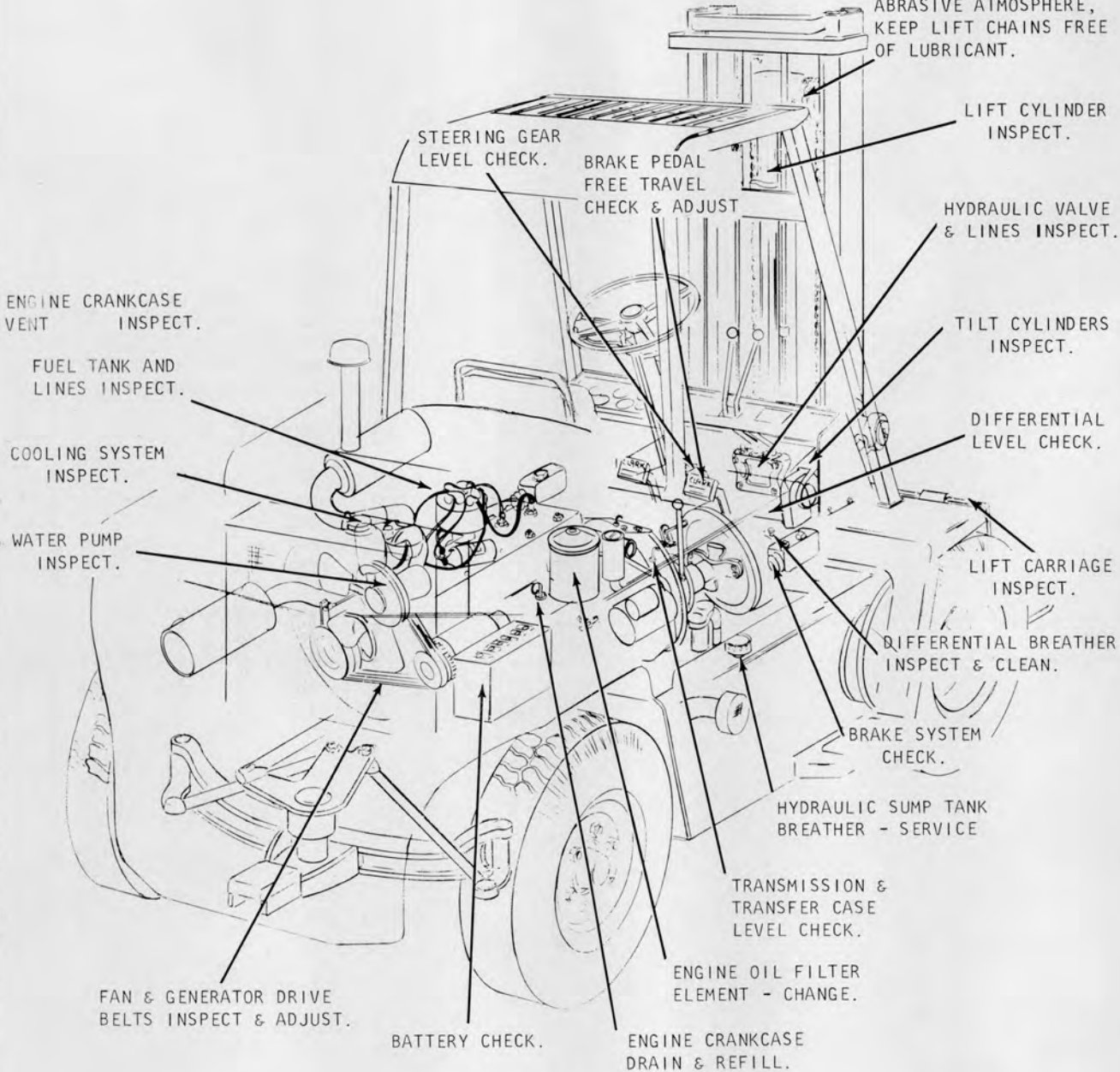

NOTE

IN ADDITION TO THE ABOVE, PERFORM THE
8 HOUR PREVENTIVE MAINTENANCE SERVICES.

Plate 7707. Lubrication and Preventive Maintenance Illustration

CONVERTER, TRANSMISSION AND TRANSFER CASE

Verify fluid level with engine operating and transmission in neutral. The combination dipstick and filler pipe is located on the right side of the transmission and may be reached through the engine compartment opening.

Fill with transmission fluid Type "A" (Armour Qualified) through the combination filler and dipstick opening. Fill to "Hot Full" mark on dipstick if transmission fluid is at normal operating temperatures. Fill to "Cold Full" mark when fluid is at a lower temperature. See Plate 7303.

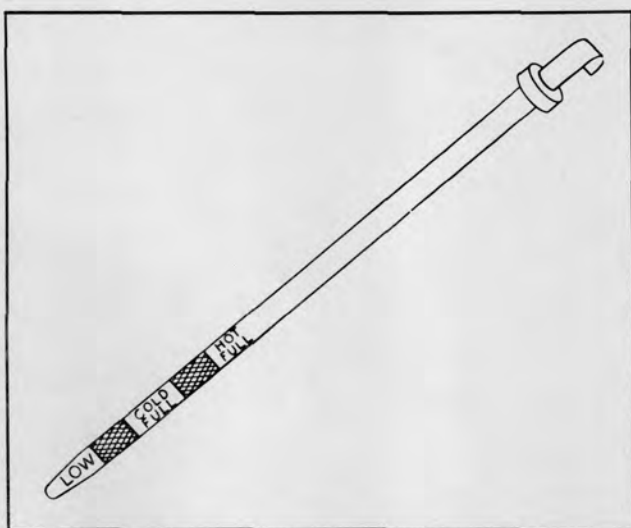

Plate 7303. Hydratork Transmission Dipstick

FUEL LINES

Make certain that fuel line connections are secure. Check fuel lines for obstructions and leaks. Check screen in fuel filler cap to make certain that it is properly installed and not damaged.

W A R N I N G

THE FUEL TANK IS AN INTEGRAL PART OF THE MACHINE FRAME AND ANY WELDING IN THIS AREA SHALL NOT BE ATTEMPTED BEFORE FIRST TAKING ADEQUATE SAFETY PRECAUTIONS. REPORT TO DESIGNATED PERSON IN AUTHORITY.

DIFFERENTIAL (ALL MODELS)

Verify differential lubricant level. Level should be maintained to the height of the fill and level plug. See Plate 7336. If lubricant is not to the height of this plug, fill with E.P.G.L. S.A.E. #90 Clark specification MS 8. do Not fill above the level of the filler plug as the excess quantity will serve no useful purpose. If the oil level is too high, it will cause excessive oil churning and attendant high oil temperature and possible leakage.

DIFFERENTIAL BREATHER

Check breather to be sure it is free of any obstruction. Remove and clean in a Stoddard type cleaning solvent if necessary. Dry with compressed air before replacing breather on differential.

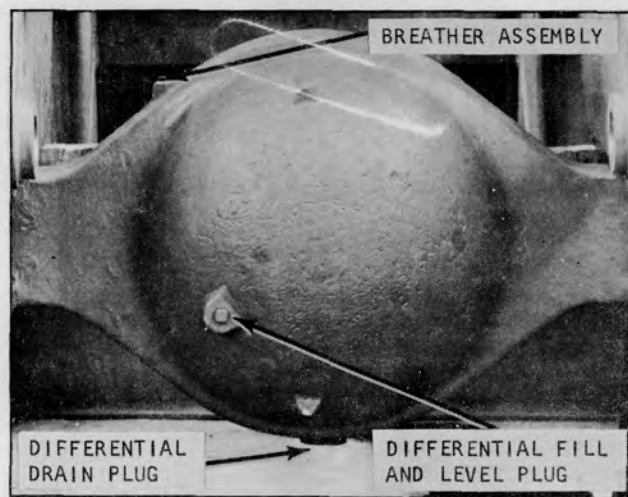

Plate 7336. Differential Drain and Fill Plugs

INDUSTRIAL TRUCK DIVISION

REGISTRATION AND REPAIRING INSTRUCTIONS

SECTION 1

SECTION 2

1. The purpose of this section is to provide instructions for the registration and repairing of industrial trucks. It is intended for the use of the operator and the maintenance personnel.

2. The operator should read these instructions carefully before operating the truck. The maintenance personnel should read these instructions before performing any repairs.

REGISTRATION

3. The operator should register the truck with the appropriate authority before using it. The registration process may vary depending on the jurisdiction.

4. The operator should ensure that the truck is in good working condition before registration. This includes checking the tires, brakes, and lights.



REPAIRING

5. The operator should follow the manufacturer's instructions for repairing the truck. If the operator is not qualified to perform the repair, they should contact a qualified technician.

6. The operator should ensure that the truck is safe to operate after any repairs. This includes testing the truck and checking for any loose parts.

7. The operator should keep a record of all repairs performed on the truck. This record should include the date of the repair, the name of the technician, and a description of the work done.

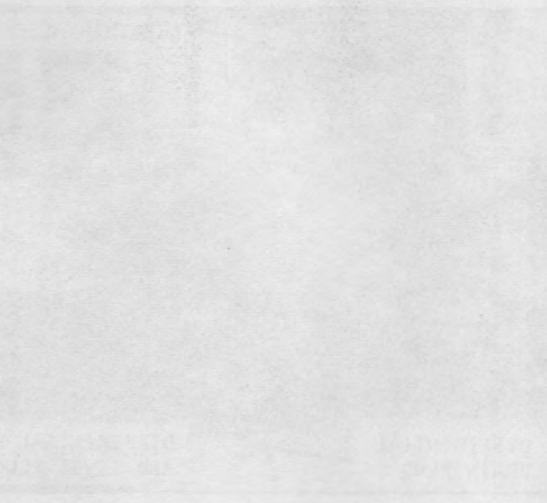

ENGINE CRANKCASE

Every 100 operating hours, drain and refill. (Drain at operating temperatures). Refill, then run engine a few minutes and add oil as necessary to bring oil level to full mark indicated on the dipstick.

Crankcase Capacity — Refer to Specifications
Service "MS" Oils
S.A.E. 10W 0° to 32° F.
S.A.E. 20W 32° to 75° F.
S.A.E. 30..... above 75° F.
or use 10W...30 MULTI-GRADE OIL.

ENGINE CRANKCASE VENTILATION BREATHER

Remove breather and oil cup by releasing spring clips. Dislodge foreign particles by washing in a Stoddard type solvent until clean. Allow to air dry. Fill oil cup to level mark with oil of same viscosity as used in engine. Replace breather after it is completely air dried.

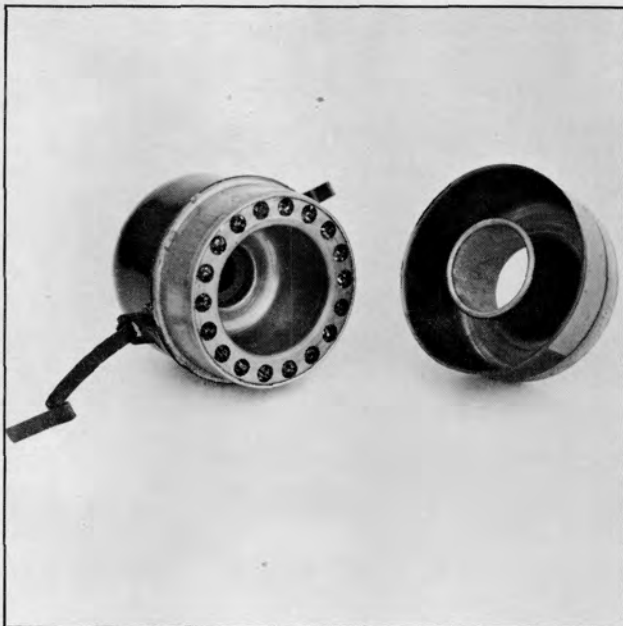

Plate 7033. Engine Breather

ENGINE OIL FILTER

The oil filter element is of the replaceable type. The element should be changed whenever the crankcase is drained. To remove the element, remove oil filter cover screw and gasket, oil filter cover, cover spring and cover gasket. Lift out oil filter element. Install new element after draining and thoroughly cleaning filter case. Install new gaskets and replace cover spring, oil filter cover and secure with oil filter cover screw.

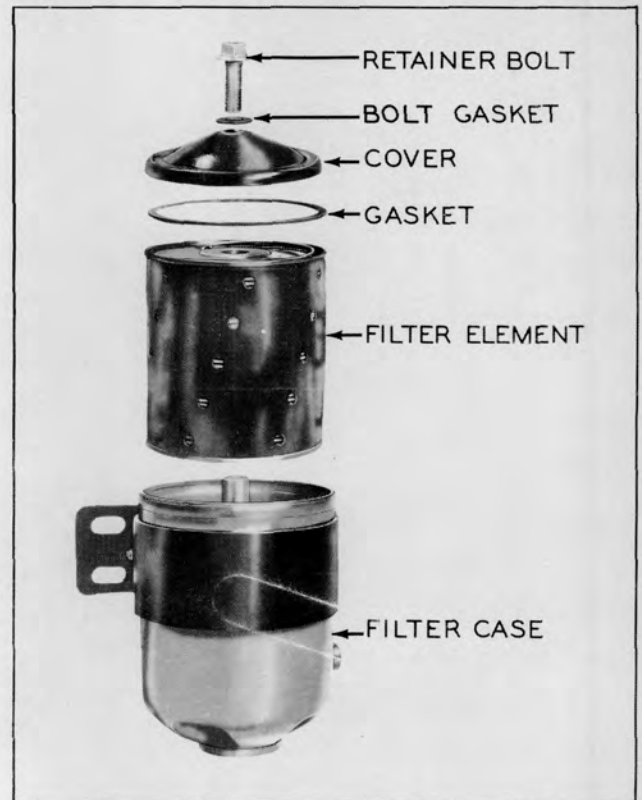

Plate 6332. Engine Oil Filter

CAUTION

START ENGINE, RUN AT IDLE FOR A FEW MINUTES, CHECK COVER AND COVER SCREW FOR LEAKS.

INDUSTRIAL TRUCK DIVISION

CHROME AIR FILTER

The oil filter element is of the...
 For removal of the filter cover...
 Cover the filter element with the...
 After cleaning the filter element...
 Cover the filter element with the...
 After cleaning the filter element...

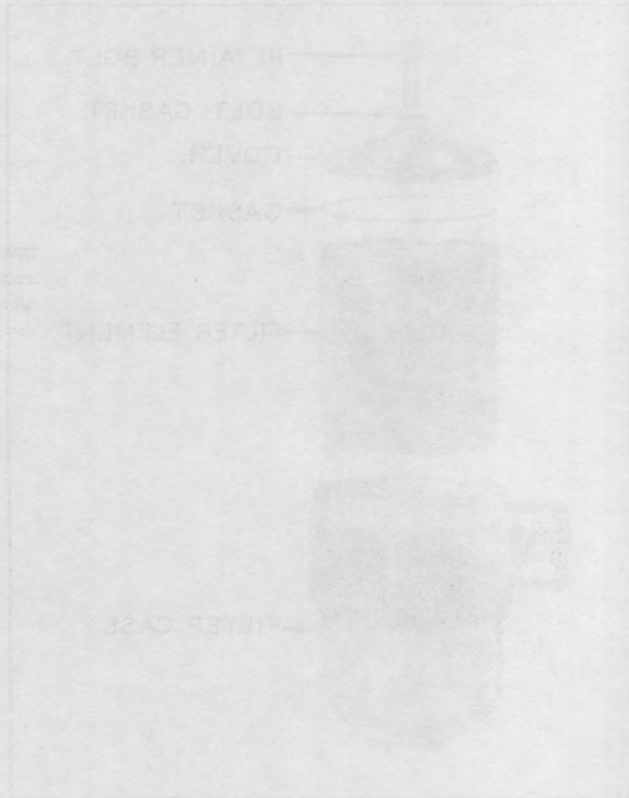

Part No. 100-100-100-100

CATION

START ENGINE, RUN AT 1000 RPM FOR 5 MIN.
 WIND UP BECK COVER AND COVER STRIP FOR
 LEFT

...the oil filter element is of the...
 For removal of the filter cover...
 Cover the filter element with the...
 After cleaning the filter element...
 Cover the filter element with the...
 After cleaning the filter element...

...the oil filter element is of the...
 For removal of the filter cover...
 Cover the filter element with the...
 After cleaning the filter element...
 Cover the filter element with the...
 After cleaning the filter element...

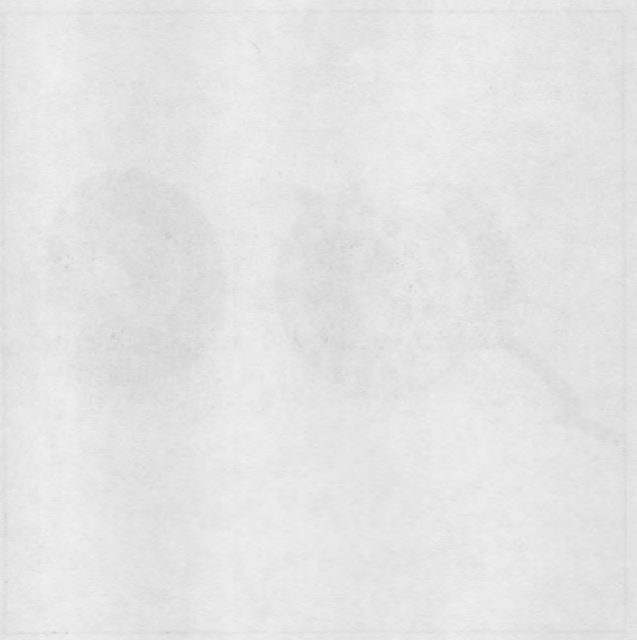

Part No. 100-100-100-100



Plate 6458. Radiator Pressure Cap

WARNING

USE EXTREME CARE IN REMOVING THE RADIATOR PRESSURE CAP. IN PRESSURE SYSTEMS, THE SUDDEN RELEASE OF PRESSURE CAN CAUSE A STEAM FLASH AND THE FLASH, OR THE LOOSENED CAP CAN CAUSE SERIOUS PERSONAL INJURY. LOOSEN CAP SLOWLY AND ALLOW STEAM TO ESCAPE.

COOLING SYSTEM

Check radiator, hoses and water pump for leaks.

Add proper amount of water or anti-freeze solution to cooling system. If anti-freeze is not available and machine is to be at rest for an appreciable length of time, drain system when temperature is likely to be 32° F, or lower. If water is added to radiator containing anti-freeze solution, always test solution in radiator with a hydrometer to determine the degree of protection. For proper amount of anti-freeze solution required to protect the cooling system, refer to instructions on anti-freeze container.

NOTE

COOLING SYSTEM CAPACITY - REFER TO SPECIFICATIONS.

Accumulated foreign material should be blown from radiator fins with compressed air. Direct air stream through radiator fins towards engine to make this process effective.

INDUSTRIAL TRUCK DIVISION

INDUSTRIAL TRUCK DIVISION

CONTRACT NO. 100-1000000000

THIS CONTRACT IS SUBJECT TO THE TERMS AND CONDITIONS OF THE

GENERAL CONDITIONS OF CONTRACT AND THE SPECIFICATIONS FOR THE

W.D. 100

CONTRACT NO. 100-1000000000

SECTION

SECTION 100-1000000000

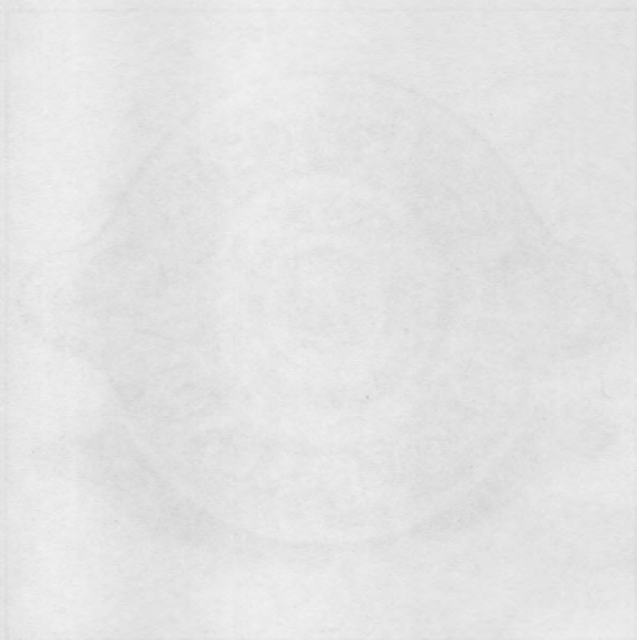

SECTION 100-1000000000

SECTION 100-1000000000

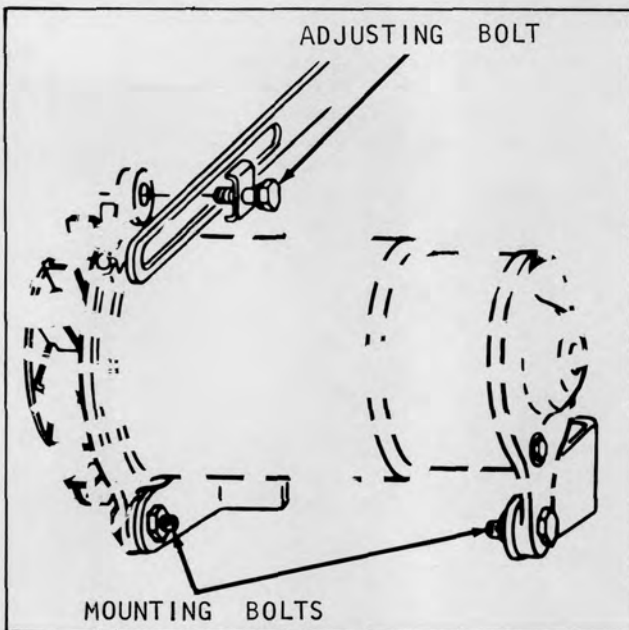

Plate 6631. Generator Drive Belt Adjustment

FAN AND GENERATOR DRIVE BELTS

The drive belts should have finger pressure deflection of 3/4 to 1 inch mid-way on long span. If belts require adjustment, use following procedure.

1. Loosen generator brace adjusting bolt and two lower mounting bolts, see Plate 6631.
2. Move generator toward cylinder block to loosen Generator Drive Belts and away from cylinder block to tighten belts. Tighten bolts when correct finger deflection is obtained.

C A U T I O N

EXERCISE CAUTION WHEN ADJUSTING BELTS. BELTS ADJUSTED TOO TIGHT WILL VERY LIKELY CAUSE

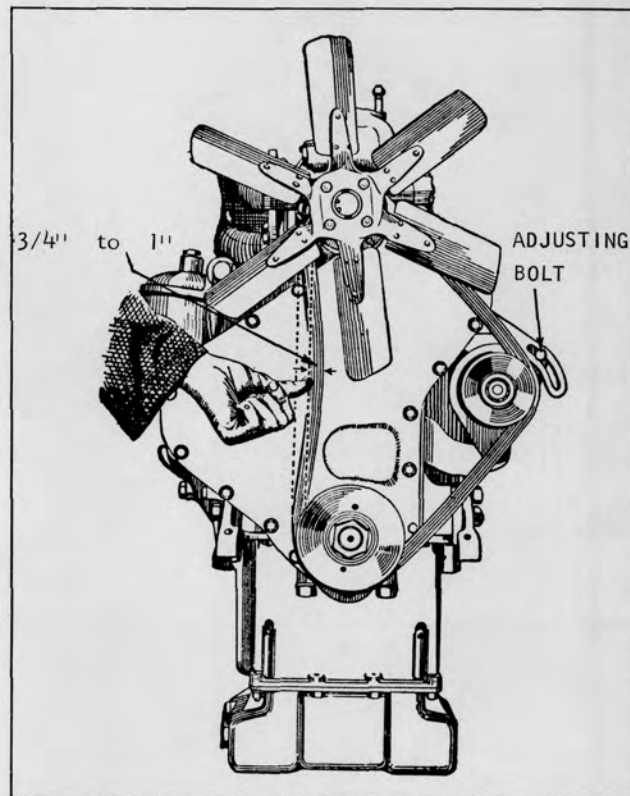

Plate 6632. Belt Deflection Check

BEARING DAMAGE. CONVERSELY, BELTS ADJUSTED TOO LOOSE WILL RESULT IN BELT WEAR AND HIGH ENGINE TEMPERATURE DUE TO BELT SLIP-PAGE.

N O T E

UPON REPLACEMENT OF DRIVE BELTS, IT WILL BE NECESSARY TO USE A MATCHED SET OF BELTS.

BRAKE PEDAL FREE TRAVEL

Using a rule, measure pedal free travel at either of the two places shown below.

Depress brake pedal by hand. When pedal meets resistance from the master cylinder, the distance traveled should be 1/2 inch -- if free travel is incorrect, adjust as follows:

1. Loosen lock nut, see Plate 7339.
2. Rotate adjuster to obtain specified pedal free travel.
3. Tighten lock nut to hold adjustment.

ACTUATION STROKE

If brake pedal travels beyond this point ----- this indicates either lack of fluid in the master cylinder; air in the system, or the brake linings require adjustment or replacement.

CLEARANCE - measured here -
TOP PEDAL POSITION -TO- WHERE
PEDAL MEETS RESISTANCE FROM THE
MASTER CYLINDER.

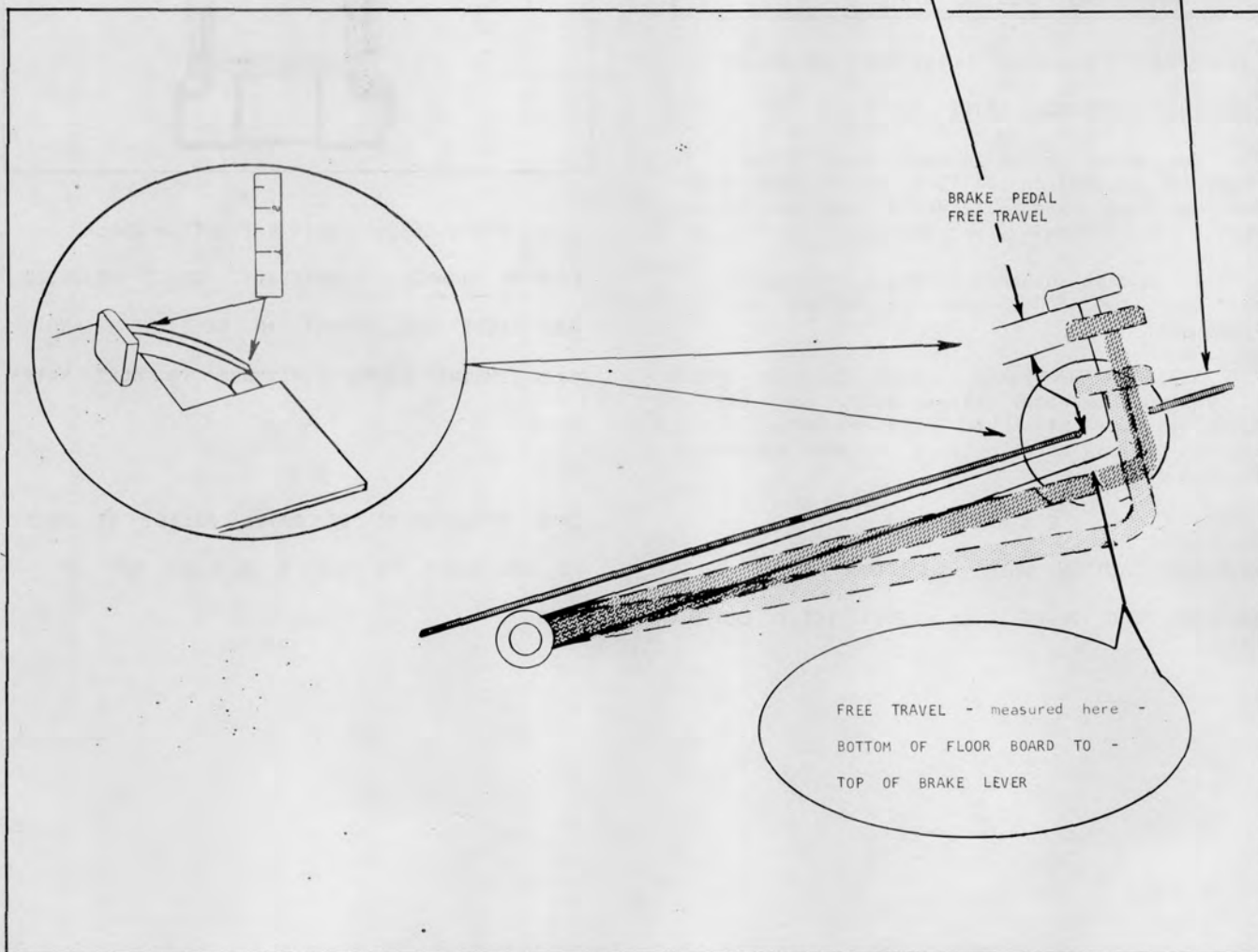

Plate 7042. Brake Pedal Check and Adjustment

BRAKE SYSTEM

Check brake fluid level in the master cylinder. Brake fluid should be within 1/4 inch of the top. Fill with SAE 70 R3 Heavy Duty Brake Fluid. Clark Part Number 1800200.

Master Cylinder Filler Cap Vent Hole:

Check cap vent hole for obstruction. Vent hole must be open at all times. Clean if necessary, see Plate 7339.

BRAKE PEDAL

A correctly adjusted brake pedal is important so that the internal ports in the master cylinder are not blocked by the cylinder piston. The following lists two important reasons for proper brake pedal free travel.

Inadequate pedal free travel will block the internal ports so that upon releasing the brake pedal fluid will be trapped in the lines and hold the brake linings in contact with the brake disc or drum, resulting in lining wear and excessive fuel consumption.

Brake Pedal Adjustment: Refer to Plate 7964 on Page 100H 302 and follow the instructions and diagrams.

WARNING

CORRECT BRAKE PEDAL FREE TRAVEL IS IMPORTANT FOR SAFE OPERATING BRAKES.

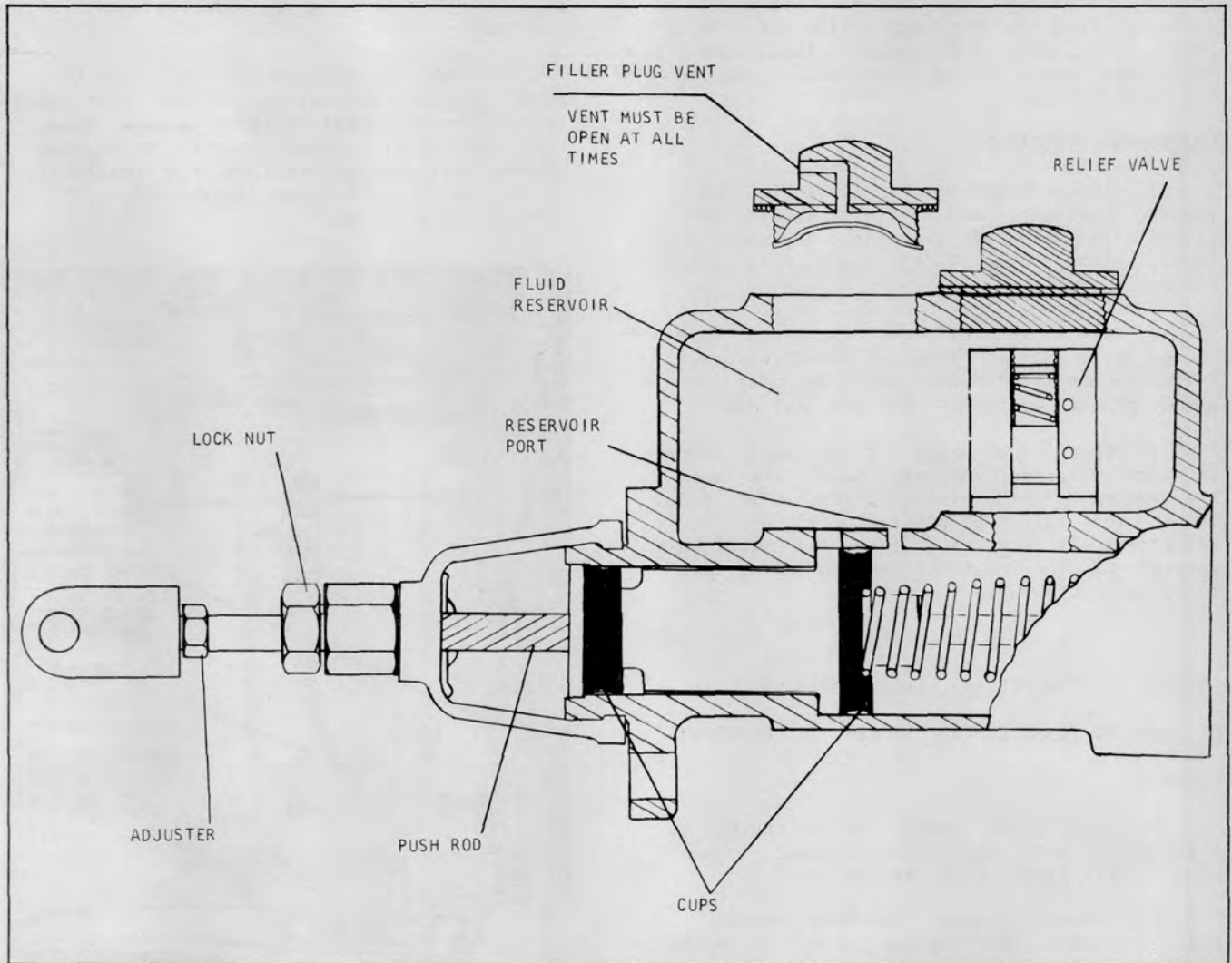

Plate 7339. Brake Pedal Adjustment

**LEFT HAND INCHING BRAKE PEDAL OPERATION
(HYDRATORK MODELS)**

The initial travel of the left hand inching brake pedal actuates an inching cylinder (similar to a brake master cylinder) causing fluid to flow under pressure to the hydratork transmission control cover. Fluid under pressure actuates the inching mechanism incorporated in the control cover and allows controlled slippage of the discs in the transmission selector packs, thereby causing either partial or complete disengagement of power from the drive wheels, even though the engine may be operating at high speed for fast lifting. As the pedal travels downward during the inching cycle there is a gradual increase in the amount of slippage between discs in the selector packs. After the pedal travel completely actuates the inching mechanism, the pedal linkage is so designed that further depression of the pedal will apply the brakes. Thus, the left hand pedal is a combination inching and brake pedal.

ADJUSTMENT PROCEDURE

1. Check brake fluid level in the inching cylinder. Brake fluid should be within 1/4 inch of the top. Replenish supply with S.A.E. 70 R3 heavy duty brake fluid.

2. Check the cylinder cap vent hole to be sure it is free of obstructions. Cylinder cap vent hole must be open to allow proper operation of the cylinder.

3. Check the pedal to be sure there is some clearance between pedal arm and the bottom of the floor plates when pedal is in the full up position. If an adjustment is necessary turn the stop bolt located at the rear of the pedal pivot to obtain clearance.

NOTE

INCHING SYSTEM FLUID LINES MUST BE FREE OF AIR TO ENABLE THE SYSTEM TO FUNCTION PROPERLY.

4. Adjust the pedal return spring so that pedal will completely retract (against stop bolt) after each depression.

5. Remove cylinder cap and depress pedal by hand. At the beginning of each inching cylinder stroke a small displacement of fluid should be noticed in the cylinder reservoir. This indicates that the

inching cylinder stroke is adjusted properly. If no displacement of fluid is observed, the inching cylinder push rod must be adjusted to a shorter length. This will allow a cylinder port to be open when the pedal is in the up position, thereby allowing fluid to return to the cylinder reservoir.

6. Check the spring loaded actuator on the cylinder push rod linkage to be sure it operates freely, lubricate with S.A.E. #20 oil if it is binding. As soon as the inching cylinder reaches its maximum stroke the spring loaded actuator should begin to telescope allowing brake linkage to energize the brakes. The left hand inching pedal has an adjustment bolt on the tang located forward of its pivot which may be adjusted in the direction necessary to enable brakes to actuate as soon as the inching cylinder stroke is complete.

If the linkage is adjusted in the above manner, depression of the left hand inching brake pedal will disengage power from the drive wheels before the brakes become applied, eliminating the possibility of trying to drive and brake the vehicle at the same time.

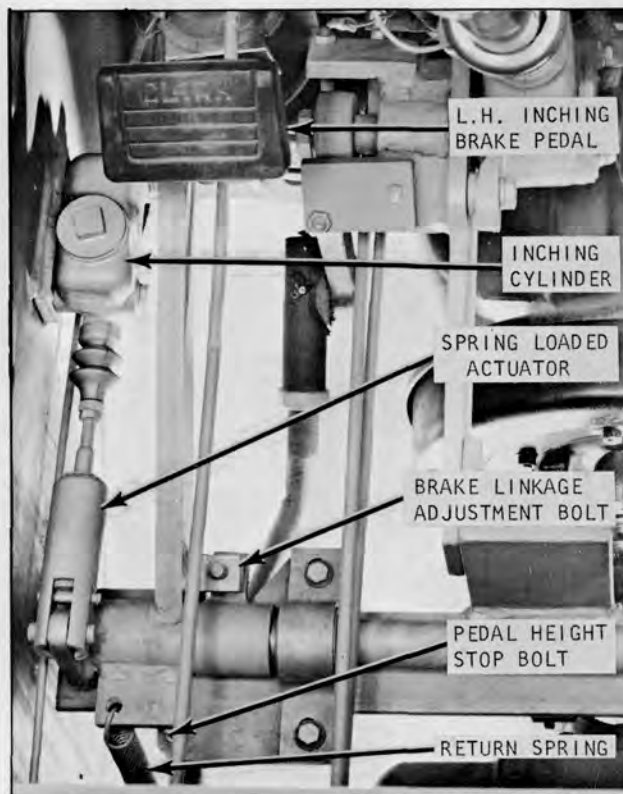

Plate 7703. Left Hand Inching Brake Pedal

LUBRICATION AND PREVENTIVE MAINTENANCE

LIFT AND TILT CYLINDERS

Check for drift, leakage at packings, damage and security of mountings (Anchor Pivot Pins, Flanges and Mounting Rings).

LIFT CHAINS

The lift chains are mounted to the chain anchors on the lift carriage and at the chain anchor rods near the lift cylinder piston head.

If it becomes necessary to adjust the lift chains place a capacity load on forks (or device if used) and adjust chains so center line of lower carriage roller is at least 1/2" above the bottom end of the inner slide channel. It is important that the chain adjustment be made with a capacity load. In this manner you will allow for chain stretch.

W A R N I N G

KEEP CLEAR OF LOAD DURING ADJUSTMENT TO AVOID INJURY IF ANY MALFUNCTION SHOULD OCCUR AND CAUSE LOAD TO FALL.

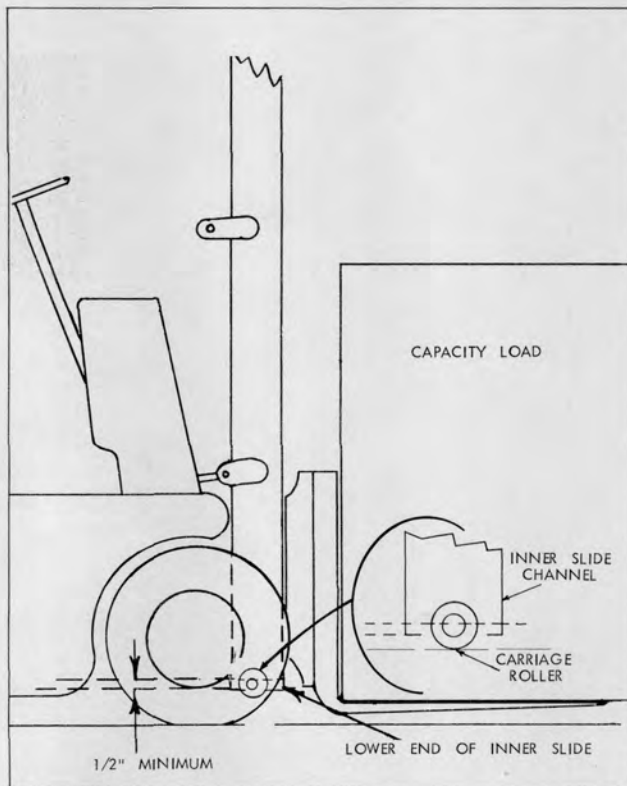

Plate 6884. Lift Chain Adjustment
(Place Maximum Load On Forks)

LUBRICATE MACHINE

C A U T I O N

WHEN LUBRICATING THE TRUCK, MAKE A VISUAL INSPECTION OF ALL HYDRAULIC LINES, FITTINGS AND ALL ELECTRICAL WIRING. LUBRICATE ALL MISCELLANEOUS LINKAGE WITH S.A.E. NUMBER 20 OIL.

HYDRAULIC CONTROL VALVE AND LINES

Inspect for damage, leakage and security of mounting.

LIFT BRACKET

Inspect for damage, bent forks etc.

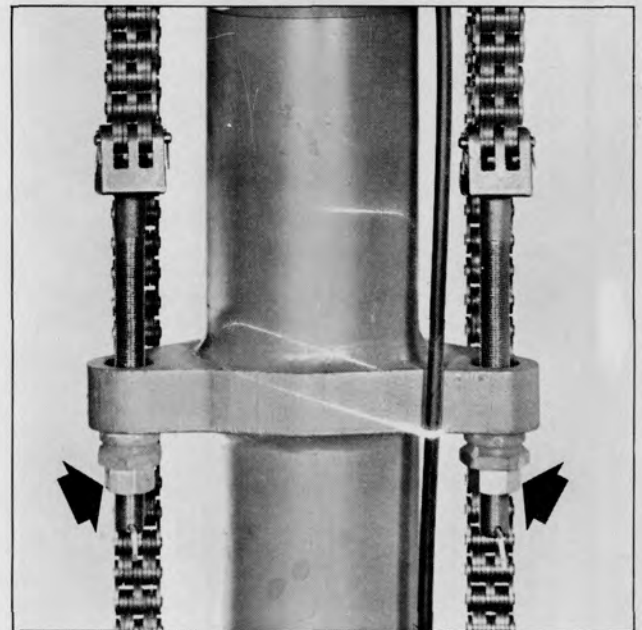

Plate 6634. Lift Chain Adjustment
(Chain Anchor Rods)

INDUSTRIAL TRUCK DIVISION



INSPECTION AND PREVENTIVE MAINTENANCE
SCHEDULE

1. PRE-OPERATION

WASH FRONT END OF TRUCK, MAKE A VISUAL

INSPECTION OF ALL WHEELS, TIRMS, TIRE

AND ALL ELECTRICAL WIRING, LUBRICATE

WHEEL BEARINGS WITH S.A.E. GRADE

20-50

HYDRAULIC CONTROL VALVE AND LINES

INSPECT FOR LEAKS, TIGHTEN AND

REPLACE AS NECESSARY

INSPECT FOR CORROSION, PAINT TOUCH UP



INSPECT THE FUEL SYSTEM, WATER PUMP, AND

THE AIR FILTER AND CLEANER TO THE

ENGINE ROOM, CHECK THE OIL LEVEL

AND ADD AS NECESSARY, CHECK THE

WATER PUMP AND BELT DRIVE, CHECK

THE BATTERY CHARGE

AND CLEAN THE BATTERY

AND RECHARGE AS NECESSARY

AND TEST THE LIGHTS

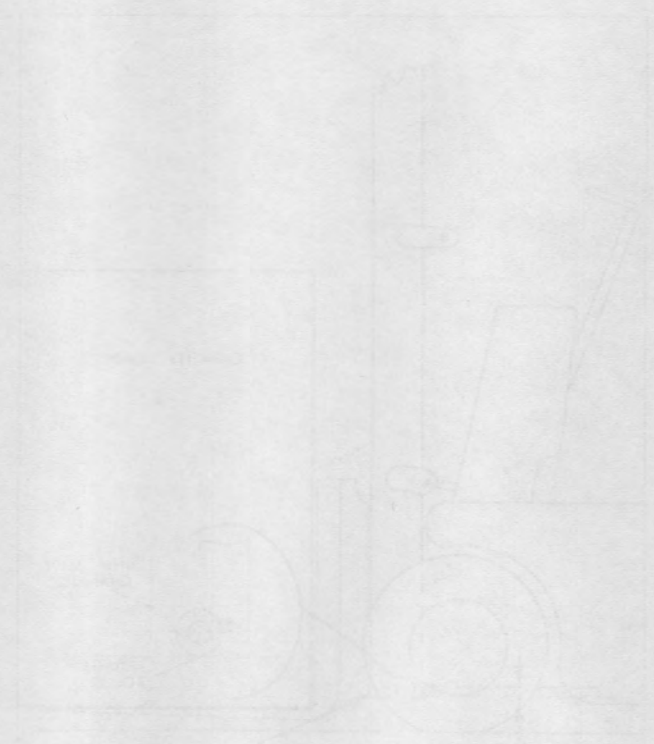

INDUSTRIAL TRUCK DIVISION
CUMMINS ENGINE COMPANY

INDUSTRIAL TRUCK DIVISION
CUMMINS ENGINE COMPANY

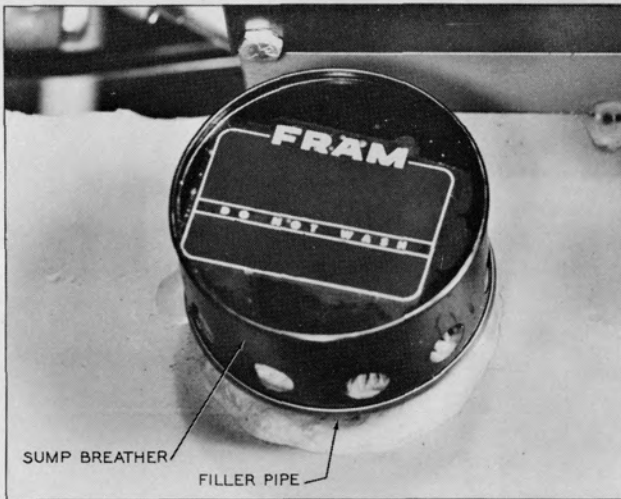

Plate 6626. Hydraulic Sump Tank

HYDRAULIC SUMP TANK BREATHER

Check breather to be sure it not dirty or clogged with foreign matter. Replace breather if dirty.



Plate 6682. Hydraulic Sump Tank & Sump Breather

INDUSTRIAL TRUCK DIVISION

OPERATION AND MAINTENANCE

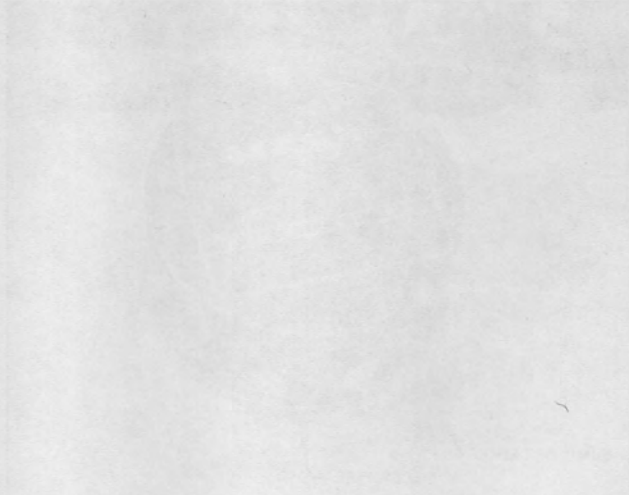
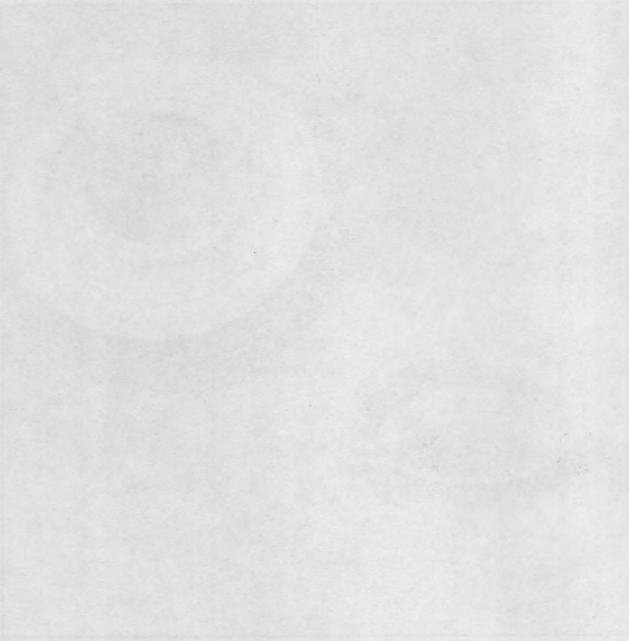

Figure 1000: Power take-off pump drive

Check operation of pump drive
in relation with engine
operation.

INDUSTRIAL TRUCK DIVISION



[The following text is extremely faint and largely illegible. It appears to be a form with several sections and fields.]

[Section 1: Header/Title area]

[Section 2: Description/Details area]

[Section 3: Data/Specs area]

[Section 4: Notes/Comments area]

[Section 5: Footer/Signature area]

NOTE: WIPE ALL DIRT FROM FITTINGS BEFORE APPLYING A GREASE GUN

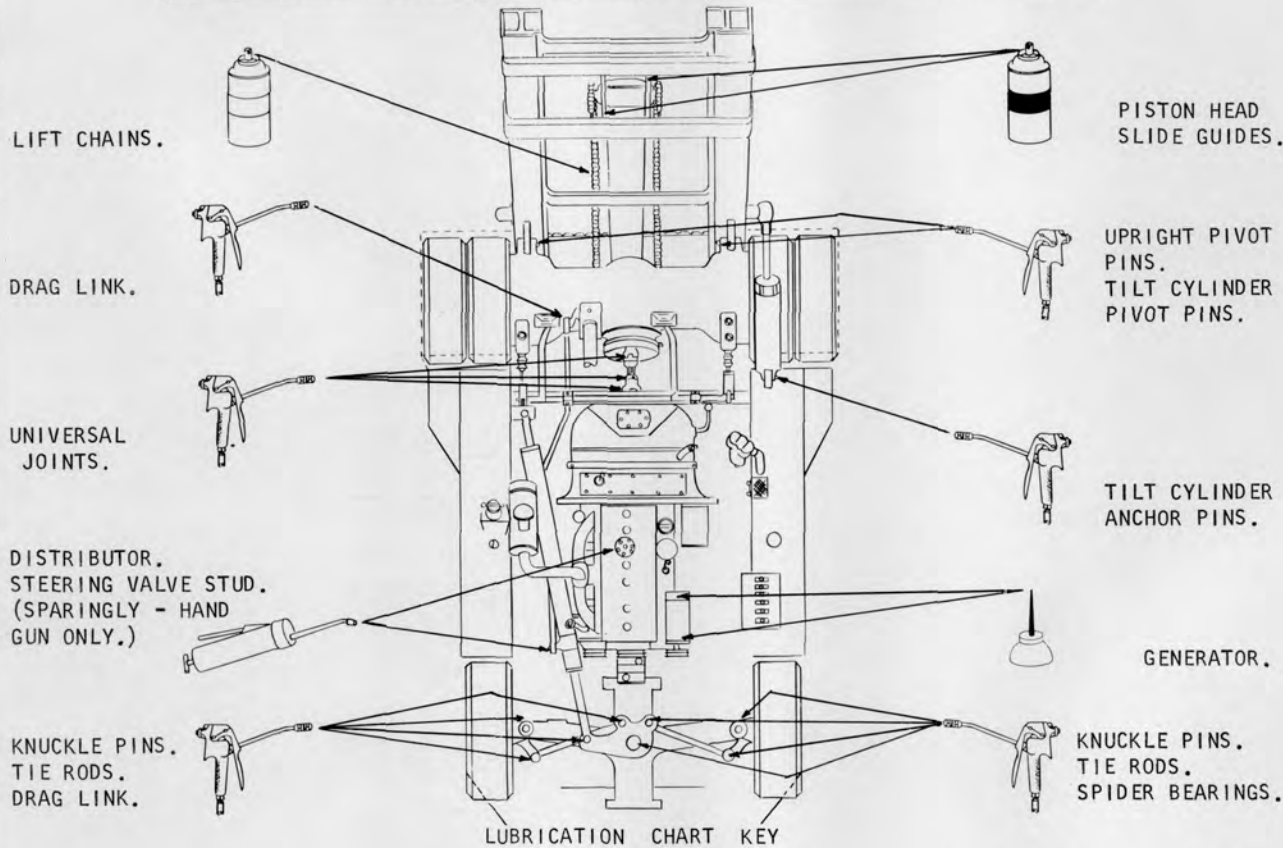

CHASSIS GREASE

ENGINE OIL: S.A.E. 20
AUTOMATIC TRANSMISSION FLUID
TYPE "A", SUFFIX "A". CLARK
PART NUMBER 879803.

OIL FILTER
CARTRIDGE KIT
1800200 HYDRAULIC BRAKE FLUID
HEAVY DUTY S.A.E 70 R3

WHEEL BEARINGS.
CLARK SPECIFICATION
MS-9C WHEEL BEARING
GREASE

HYDRAULIC OIL CLARK
SPEC. MS 68 885385

CHASSIS GREASE

REFER TO PAGE 100H 1815
FOR LUBRICATION PROCEDURE

ENGINE OIL: S.A.E. 10 W 0° - 32°F.
S.A.E. 20 W 32° - 75°F.
S.A.E. 30 above 75°F.
Or use 10 W - 30 MULTI-GRADE OIL.

GRAPHITE GREASE

886399 CHAIN LUBE

GEAR LUBE. S.A.E. 90

SLIDING TANDEM LUBE
CLARK NUMBER 886396.

EXTREME PRESSURE S.A.E. 90 GEAR
LUBE CLARK SPECIFICATION MS-8.

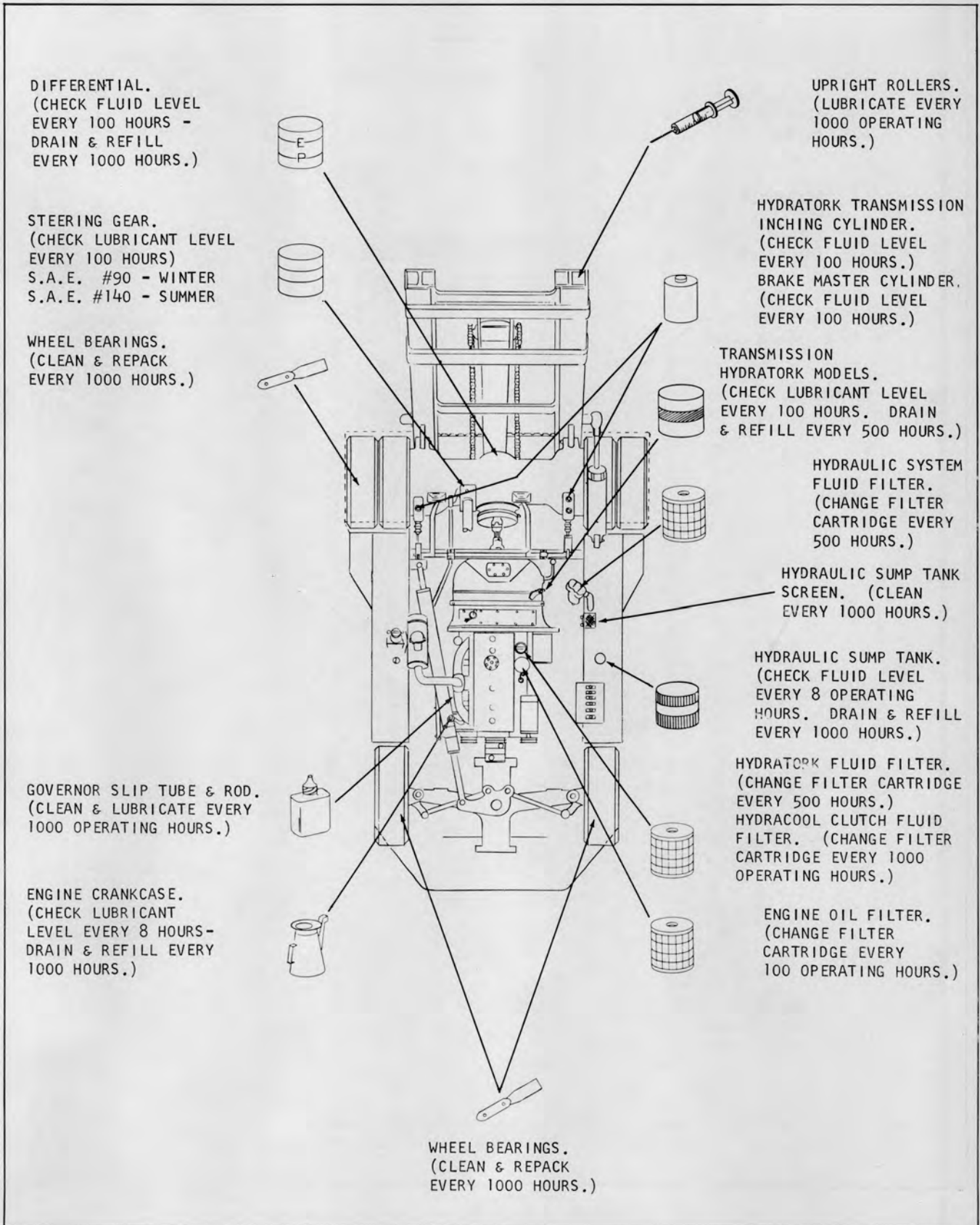

500 HOURS

STEAM CLEAN MACHINE

NOTE

REFER TO DIESEL
ENGINE MANUAL FOR
MACHINES SO EQUIPPED

CHECK SECURITY OF MOUNTING ON
ALL NUTS, BOLTS AND CAPSCREWS.

CONVERTER, TRANSMISSION
AND TRANSFER CASE FILTER
ELEMENT CHANGE.
(HYDRATORK MODELS)

FUEL PUMP SEDIMENT
BOWL & SCREEN CLEAN.

INTAKE AND EXHAUST
MANIFOLD CHECK.

EXHAUST SYSTEM
CHECK.

STEERING AXLE
AND LINKAGE
CHECK - ADJUST

STEERING GEAR
ADJUST.

CONVERTER, TRANSMISSION
AND TRANSFER CASE DRAIN
AND REFILL.
(HYDRATORK MODELS)

UNIVERSAL JOINTS
CHECK.

HYDRAULIC SUMP TANK
FILTER ELEMENT CHANGE.

NOTE

IN ADDITION TO THE ABOVE, PERFORM THE 8 HOUR
AND 100 HOUR PREVENTIVE MAINTENANCE SERVICES.

Plate 7708. Lubrication and Preventive Maintenance Illustration

FUEL PUMP STRAINER

The fuel filter and sediment bowl should be cleaned every 500 operating hours. Remove and clean sediment bowl. If fuel strainer is dirty, install a new strainer assembly and gasket. Do not reuse old gasket.

FUEL PUMP

To determine if the fuel pump is defective, remove the fuel tank supply line at the pump and blow out line with compressed air to remove any possible obstructions. Reconnect fuel tank line and disconnect pump to carburetor line. Install a fuel pressure gauge, by placing a "T" in the line, and run engine at 1800 R.P.M. with all lines connected. Fuel pump pressure should be between 1 1/2 and 2 1/4 pounds. If the fuel pump pressure is not within this range the pump should be removed for repair or replacement.

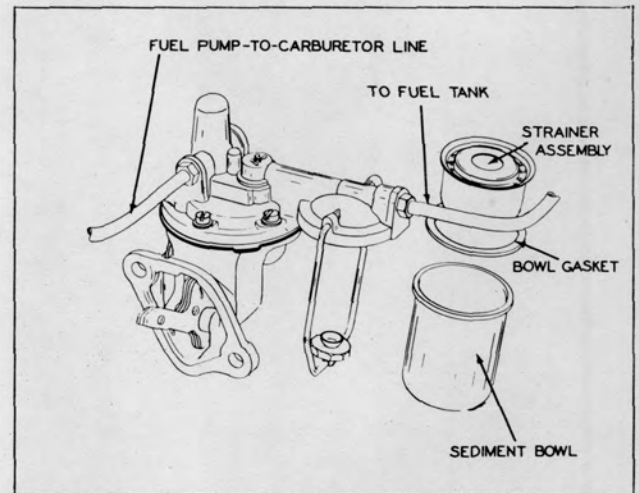

Plate 6432. Fuel Pump & Sediment Bowl

C A U T I O N

TO AVOID CREATING A FIRE HAZARD CARE SHOULD BE TAKEN SO THAT GASOLINE IS NOT SPILLED DURING THESE OPERATIONS.

N O T E

DIESEL ENGINE MODELS

REFER TO ENGINE OPERATORS MANUAL

INDUSTRIAL TRUCK DIVISION

OPERATOR'S MANUAL



The following information is provided for the operator's reference. It is intended to provide a general overview of the truck's operation and maintenance requirements. For detailed information, consult the operator's manual and the maintenance manual.

The truck is designed to operate on a variety of surfaces, including paved roads, dirt roads, and off-road terrain. The operator should be familiar with the truck's performance characteristics and limitations for each type of surface.

The truck is equipped with a variety of safety features, including seat belts, air brakes, and a steering wheel. The operator should always use these features and follow the safety instructions provided in the operator's manual.

The truck is designed to be easy to operate and maintain. The operator should follow the instructions in the operator's manual and the maintenance manual to ensure the truck is always in good working order.

The truck is designed to be easy to operate and maintain. The operator should follow the instructions in the operator's manual and the maintenance manual to ensure the truck is always in good working order.

The truck is designed to be easy to operate and maintain. The operator should follow the instructions in the operator's manual and the maintenance manual to ensure the truck is always in good working order.

TRANSMISSION OIL FILTER (HYDRATORK MODELS)

The oil filter element is of the replaceable type. The element should be changed whenever the transmission is drained. To remove element, remove filter cover retainer, cover, gasket, and spring. Lift out filter element and thoroughly clean filter body. Install new element. Use a new gasket and install spring and cover. Secure cover with retainer.

NOTE

OIL FILTER SHOULD BE REPLACED EACH TIME OIL IS CHANGED OR WHEN A REPAIR IS MADE ON TRANSMISSION OR TRANSFER CASE.

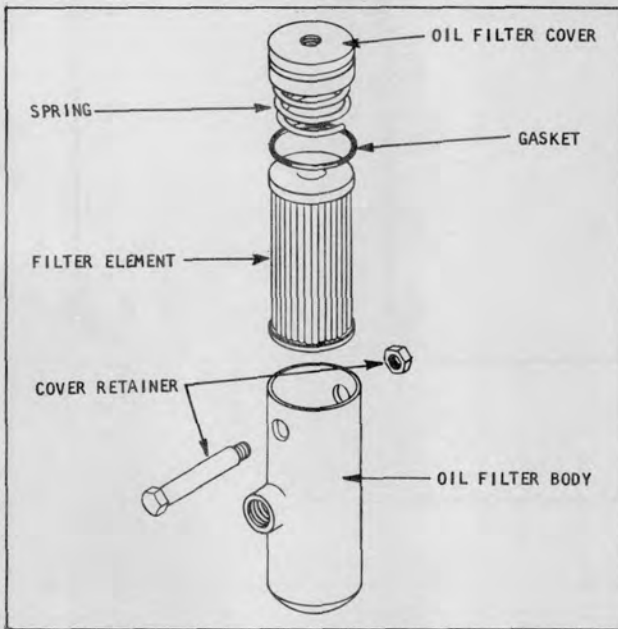

Plate 7234. Transmission Oil Filter

CONVERTER, TRANSFER CASE AND TRANSMISSION SUMP SCREEN. (HYDRATORK MODELS)

1. Drain transmission and transfer case at operating temperatures. See Plate 7710 on following page for location of drain plugs.

CAUTION

DO NOT USE FLUSHING OIL OR COMPOUND TO FLUSH SYSTEM.

2. Remove and clean transmission sump screen in a Stoddard type solvent. Dry with filtered compressed air - directing air thru neck of screen.



Plate 7235. Transmission Sump Screen

3. It is recommended that a new "O" ring be used when installing the sump screen.

4. Refill transmission and transfer case thru the combination filler and dipstick opening with Transmission Fluid Type "A" Armour Qualified. Clark part number 879803. Fill to cold full mark on oil level dipstick.

5. Operate engine approximately 4 minutes to completely charge the converter. Recheck level and fill to "cold full" mark on dipstick - with engine operating and transmission in neutral.

6. If the oil is to be checked after the machine has been working for a period of time and the transmission fluid has reached normal operating temperatures the transmission should be filled to the "Hot Full" mark on the dipstick - with engine operating and transmission in neutral.

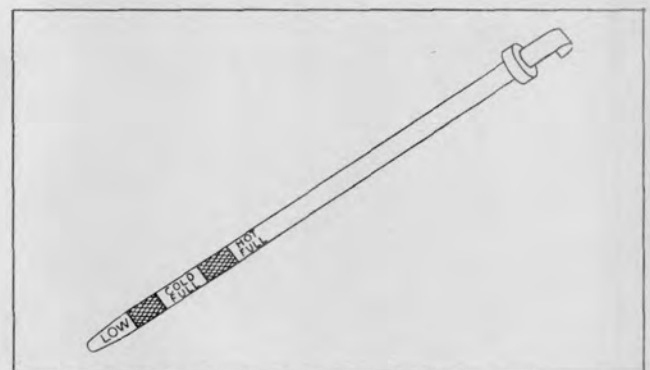

Plate 7303. Transmission Dipstick

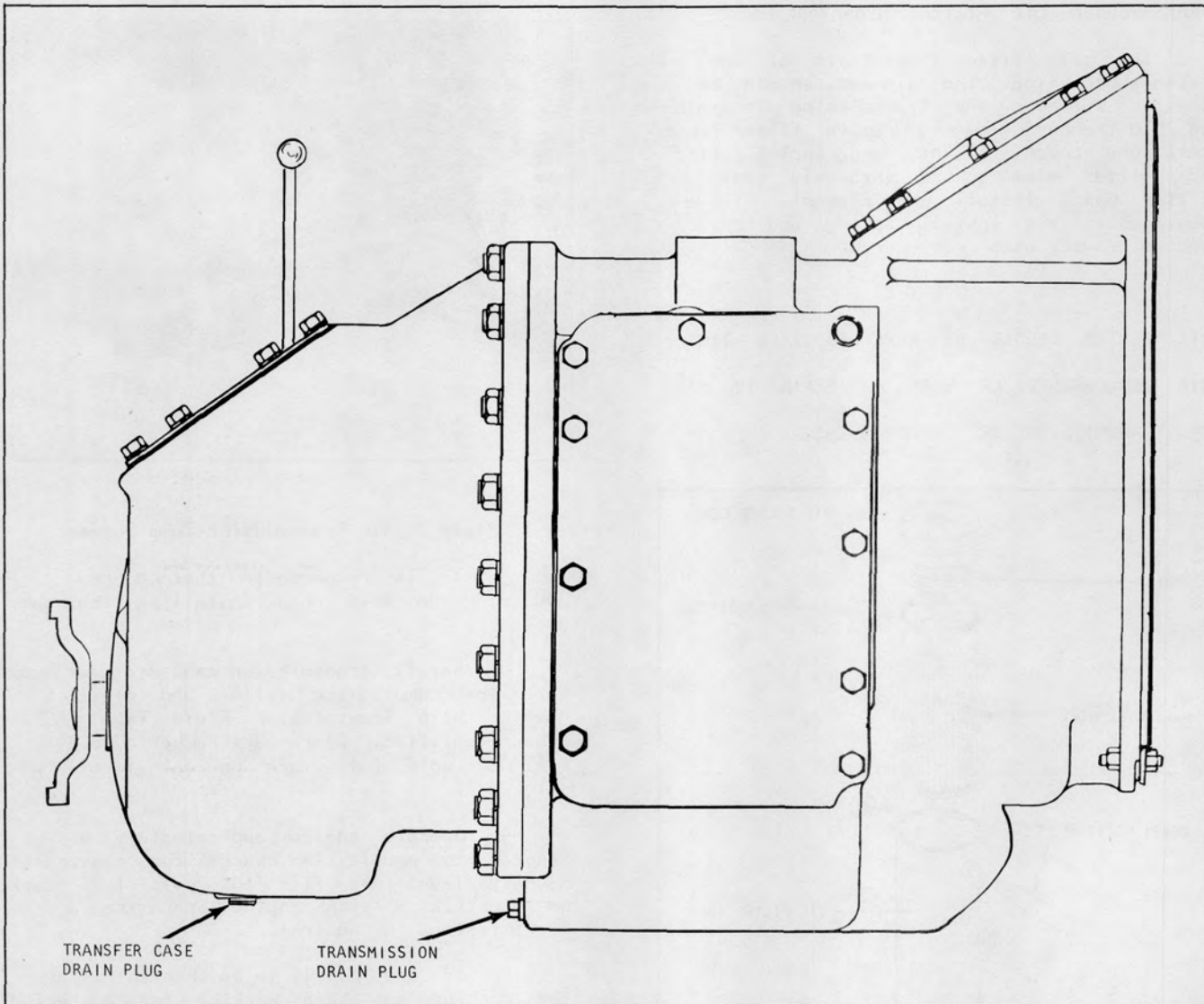

Plate 7710. Transfer Case and Transmission Drain Plugs

HYDRAULIC SYSTEM FLUID FILTER

Frequency of element change depends on individual applications. Replacement of original element after first 50 hours of operation is recommended, generally each 500 thereafter will insure maximum filtration.

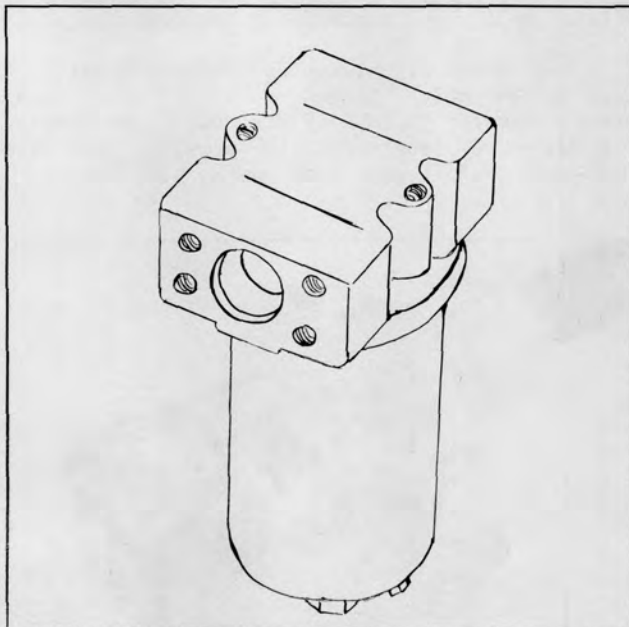

Plate 7656. Typical Hydraulic Fluid Filter

DISASSEMBLY

1. Lower upright. Shut engine off.
2. Remove drain plug from filter case and allow fluid to drain in a suitable container.
3. Unscrew the retainer bolt allowing the case and filter element to be removed from the filter base.
4. Remove the sealing ring, filter element, spring, retainer bolt and gasket from the case.
5. Discard the element, sealing ring and retainer bolt gasket.
6. Thoroughly clean the filter case in a Stoddard type cleaning solvent and allow to dry.

REASSEMBLY

1. Place a new gasket on the retainer bolt and insert bolt in filter case. Slide the spring over the retainer bolt and place a new element in the case so that it rests upon the spring.
2. Using a new sealing ring install the case sub-assembly to its base and securely tighten the retainer bolt. Install the drain plug and its gasket in the case and tighten.

CAUTION

START ENGINE AND OPERATE HYDRAULIC CONTROLS SEVERAL TIMES, CHECK OIL FILTER FOR LEAKS. IF ANY LEAKS ARE EVIDENT, CORRECT AS REQUIRED.

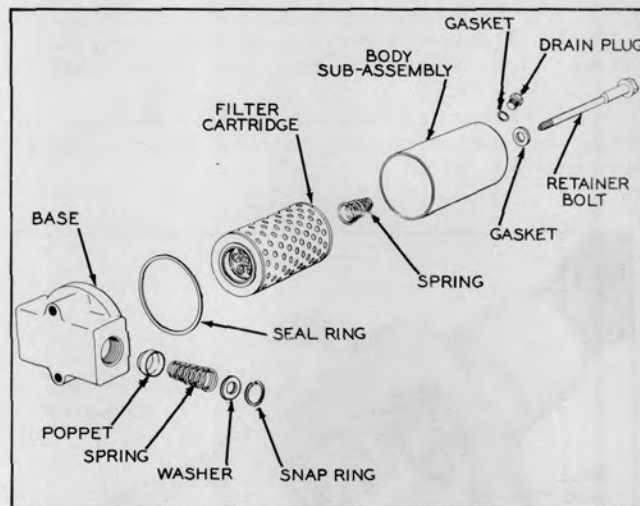

Plate 6433. Typical Hydraulic Fluid Filter Components

STEERING GEAR

Steering gear adjustments must be made in the following manner (see Plates 6636 and 6637).

Always check worm bearing thrust adjustment, and adjust if necessary, before making sector gear lash adjustment.

Before making above adjustments, the following preliminary operations are necessary.

1. Disconnect steering drag link from pitman arm. Note relative position of drag link parts when disconnecting link so the parts may be re-assembled correctly.

2. Check lubricant level in steering gear housing. If low, add enough lubricant to bring level up to filler plug hole. (Use AMOCO Lithium Multipurpose Grease or its equivalent.)

3. Tighten steering gear housing to frame side member bolts, see Plate 6636.

4. Determine straight-ahead position of steering mechanism by turning steering wheel to extreme right.

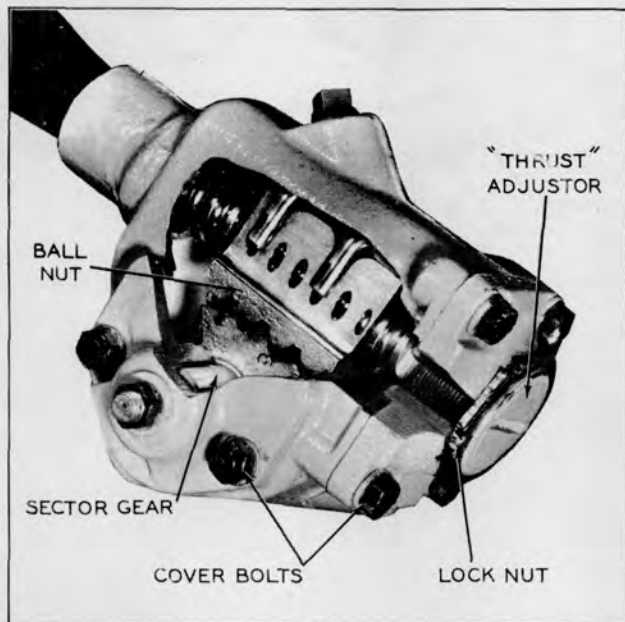

Plate 6636. Steering Gear Thrust Adjustment (Worm Bearings)

CAUTION

APPROACH EXTREME ENDS CAUTIOUSLY; WORM BALL NUT MUST NOT STRIKE ENDS WITH ANY DEGREE OF FORCE.

Then turn to extreme left, counting the exact number of turns from right to left end. Turn wheel back one-half number of wheel turns. Mark wheel with respect to steering column so center position may readily be found during adjustment procedures.

Worm Bearing THRUST Adjustment: Refer to Plate 6636 and proceed as follows:

1. Check tightness of cover bolts, see Plate 6636. Loosen lock nut and turn lash adjuster screw (Plate 6637) counter-clockwise a few turns to provide clearance between sector gear and worm ball nut.

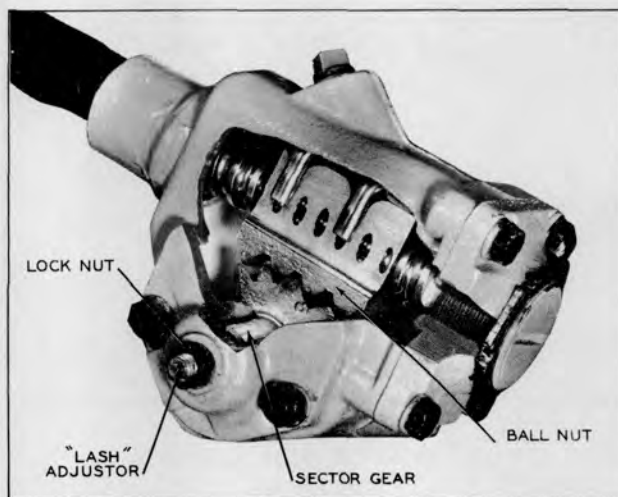

Plate 6637. Steering Gear Lash Adjustment (Sector Gear)

2. Turn steering wheel GENTLY to one extreme end. Turn wheel back one full turn. With spring scale on spoke of wheel, measure pull required to KEEP WHEEL MOVING. Pull on scale should be made at right angles to wheel spoke. If pull is within 1 1/2 to 2 pounds, proceed to lash adjustment in the following paragraphs. If pull is not within 1 1/2 to 2 pounds, adjust worm bearings. The pitman shaft adjustment must be made if worm bearing check is accomplished, or if the worm bearings are adjusted.

3. If it is necessary to adjust the worm bearings, loosen lock nut and then turn worm bearing adjuster nut clockwise until all end play is removed, see Plate 6636. Using spring scale, as directed in Step 2, check pull and readjust as necessary; then tighten lock nut securely.

LUBRICATION AND PREVENTIVE MAINTENANCE

Sector Gear Lash Adjustment: Refer to Plate 6637, and proceed as follows:

1. Steering Gear Mechanism must be in straight ahead position as previously explained.

2. Turn lash adjuster screw clockwise to remove all lash between gear teeth. Tighten adjuster screw lock nut. Position spring scale on steering wheel so pull may be made at right angles to wheel spoke.

3. Measure pull while wheel is TURNED THROUGH CENTER POSITION. Readjust if reading is not within 2 1/2 to 3 pounds.

4. Tighten adjuster screw lock nut, check pull again.

5. After adjustments are made, install drag link on pitman arm.

NOTE

IF STEERING LINKAGE ADJUSTMENT IS NECESSARY
DO NOT INSTALL DRAG LINK TO PITMAN ARM.

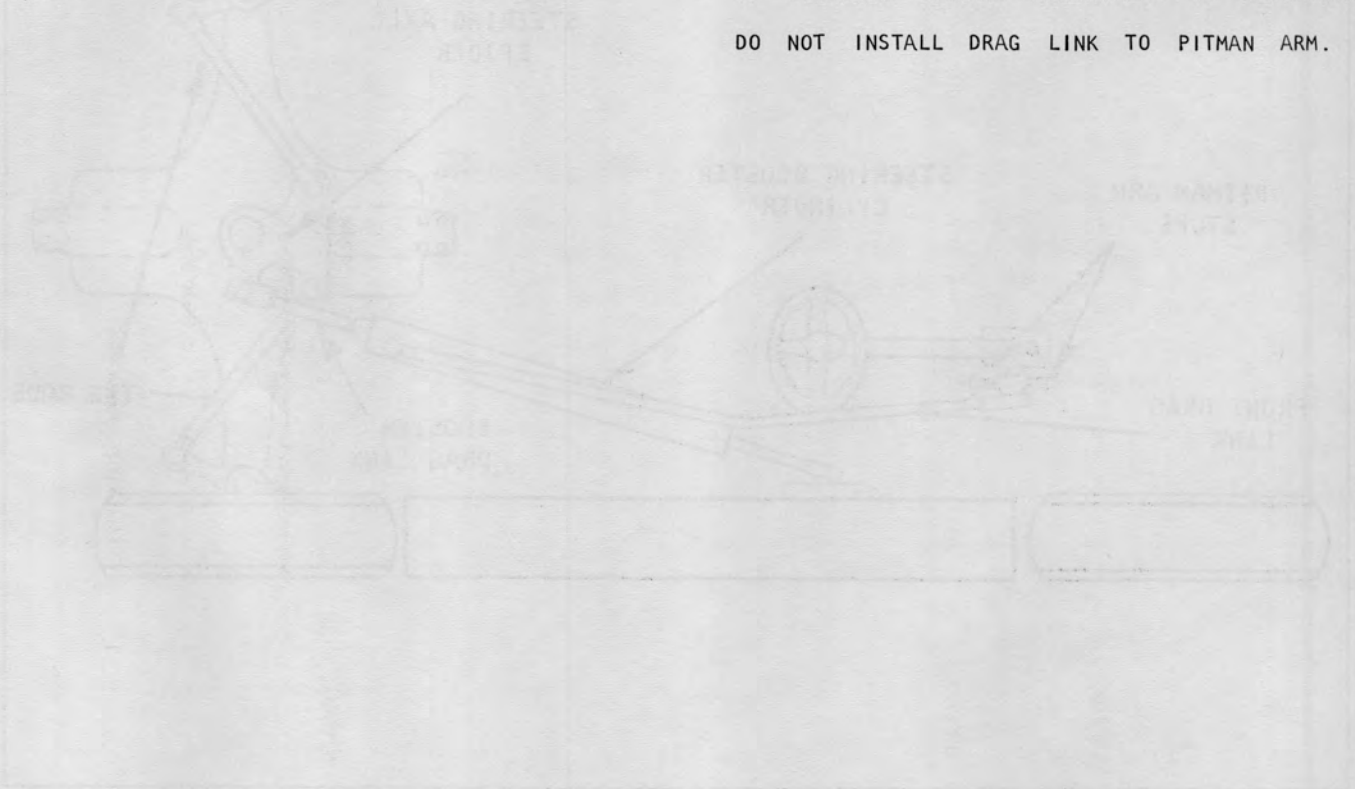

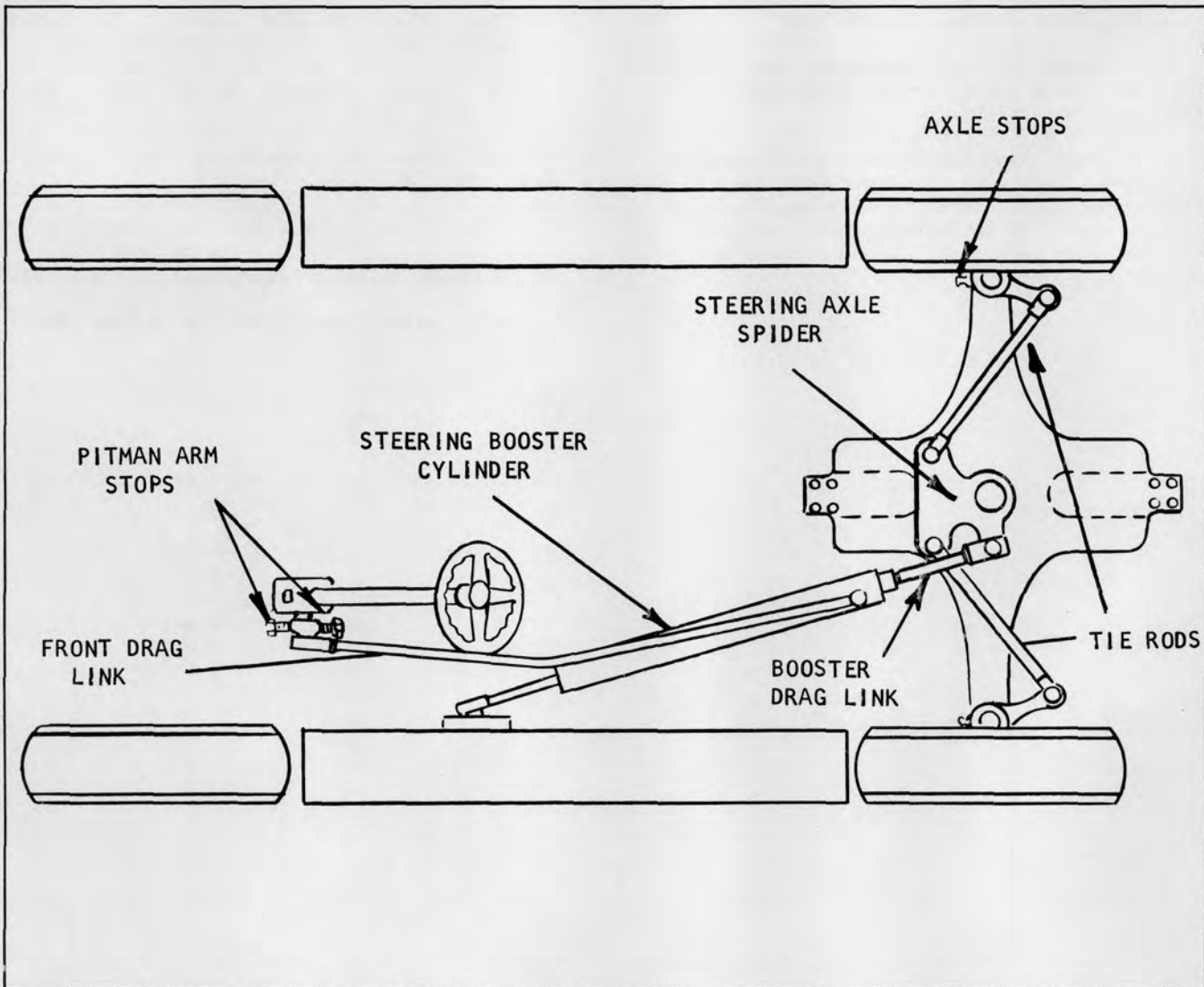

Plate 7340. Steering Linkage

STEERING AXLE AND LINKAGE ADJUSTMENT

1. Raise the rear of the machine until steering wheels clear the ground.

WARNING

PRIOR TO ANY ADJUSTMENT OF THE LINKAGE, PLACE BLOCKING UNDER MACHINE FRAME SO IT CANNOT BECOME LOWERED BY ACCIDENT. BLOCKING MUST BE OF ADEQUATE STRENGTH TO SUPPORT THE WEIGHT OF THE MACHINE.

2. The steering wheels should track square with the drive wheels with no toe-in or toe-out. If adjustment is necessary loosen the lock nuts at the tie rod ends and turn each tie rod in a manner so they will be the same length when the correct adjustment is obtained. Tighten tie rod lock nuts to secure this adjustment.

3. Disconnect the steering booster socket from the steering axle spider noting the relative position of the socket parts so they may be re-installed correctly after checking wheels for correct turning geometry.

4. Check wheels for correct turning geometry by turning the wheels all the way for a left turn - this should allow



INDUSTRIAL TRUCK DIVISION



LUBRICATION AND PREVENTIVE MAINTENANCE

the left wheel to attain an angle of 72 degrees to the frame. If an adjustment is necessary, the axle stop on the left side should be turned in or out whichever is necessary to achieve the correct angle. Repeat this procedure in a right turn with the opposite wheel and adjust the right axle stop as required.

WARNING

IF THE STEERING BOOSTER CYLINDER IS TO BE ACTUATED UNDER POWER DO SO ONLY WITH THE ENGINE RUNNING AT IDLE SPEED, USING EXTREME CARE TO KEEP CLEAR OF MOVING LINKAGES TO PREVENT PERSONAL INJURY.

5. Collapse the booster cylinder until bottomed out. Extend booster cylinder from collapsed position 1/2". Adjust socket on end of rear drag link so that grease fitting lines up with center of spider ball. (Wheels remaining in the right turn position against axle stop). Before securing socket lock nut position the booster cylinder so that the control ball stud points down and toward the center of the axle at an angle of about 10 degrees to the vertical. (This is necessary to prevent mechanical interference of linkage while turning.)

6. Turn wheels to straight ahead position and disconnect drag link at pitman arm.

7. Determine center position of steering gear. (Refer to Steering Gear adjustments for correct procedure.)

8. With Steering Gear centered; adjust drag link socket so that the grease fitting lines up with the centerline of the pitman arm ball stud and secure with lock nut and cotter pin.

9. Back off pitman arm stop bolts and slowly turn wheel until steering knuckle contacts axle stop bolt. Turn pitman arm stop until it contacts pitman arm. Lock in this position. Repeat this procedure with the remaining pitman arm stop bolt with the wheels turned in the opposite direction.

10. Turn the handwheel until wheels are in straight ahead position. Remove handwheel and replace on steering column with the center spoke aligned minus or plus 10 degrees with the center line of the machine, the center spoke pointing back.

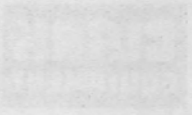

INDUSTRIAL TRUCK DIVISION



1. The purpose of this document is to provide a comprehensive overview of the Industrial Truck Division's operations and performance for the fiscal year 2023. This report will cover key areas such as sales, production, and customer satisfaction.

2. The Industrial Truck Division has achieved significant milestones in 2023, including a record-breaking sales volume and improved operational efficiency. These achievements are a result of our commitment to innovation and customer service.

3. Our primary focus in 2023 was on expanding our market reach and strengthening our relationships with existing customers. We have successfully launched several new product lines and implemented strategic marketing initiatives.

4. The success of our division is attributed to the dedication and hard work of our employees. We have fostered a culture of collaboration and continuous improvement, which has enabled us to overcome challenges and achieve our goals.

5. In addition to our strong financial performance, we have also made significant investments in research and development. This has allowed us to stay at the forefront of the industry and introduce cutting-edge technologies.

6. Our commitment to sustainability and environmental responsibility has been a key focus area. We have implemented various initiatives to reduce our carbon footprint and promote ethical sourcing practices.

7. Looking ahead, we are optimistic about the future of the Industrial Truck Division. We anticipate continued growth and success as we expand our global presence and introduce new products to the market.

8. We are grateful for the support and trust of our customers and stakeholders. We will continue to strive for excellence and provide the highest quality products and services to meet their needs.

9. This report serves as a summary of our achievements and a roadmap for our future endeavors. We are confident that our dedication and hard work will lead to a bright and successful future for the Industrial Truck Division.

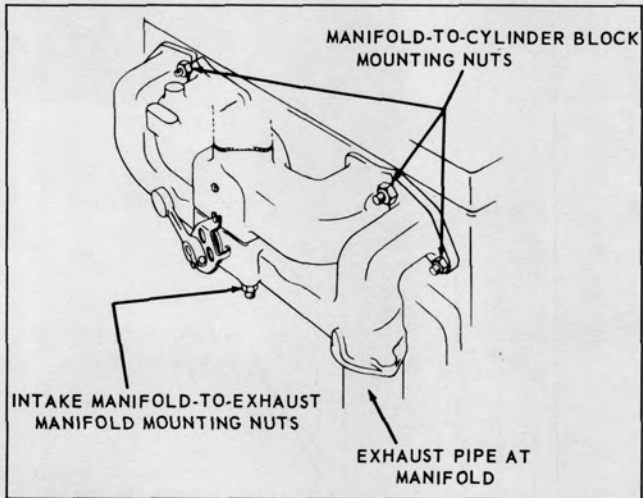

Plate 6269. Intake and Exhaust Manifolds

INTAKE AND EXHAUST MANIFOLDS

1. Inspect gaskets for leaks and inspect security of manifold nuts.
2. Inspect exhaust pipe and muffler for damage, leakage and security of mountings.

NUTS, BOLTS AND CAP SCREWS

Check security of mounting, tighten as required.

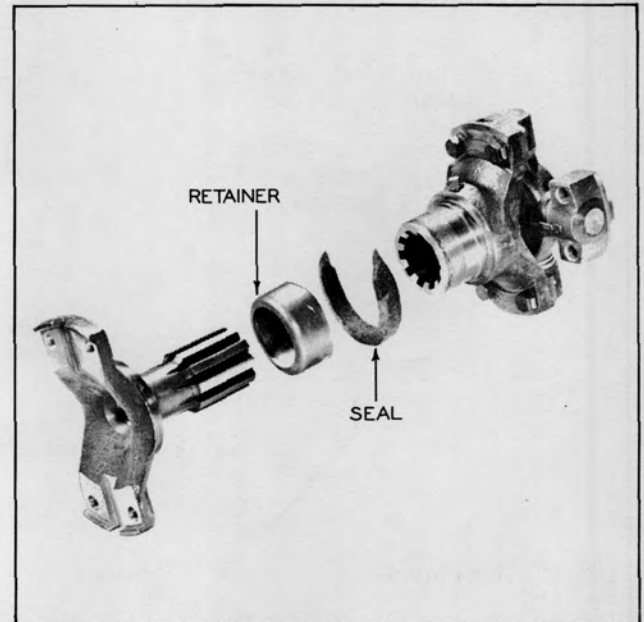

Plate 6440. Propeller Shaft

UNIVERSAL JOINTS

Inspect propeller shaft and universal joints for security of mounting and excessive bearing wear.

1000 HOURS

ENGINE TUNE UP

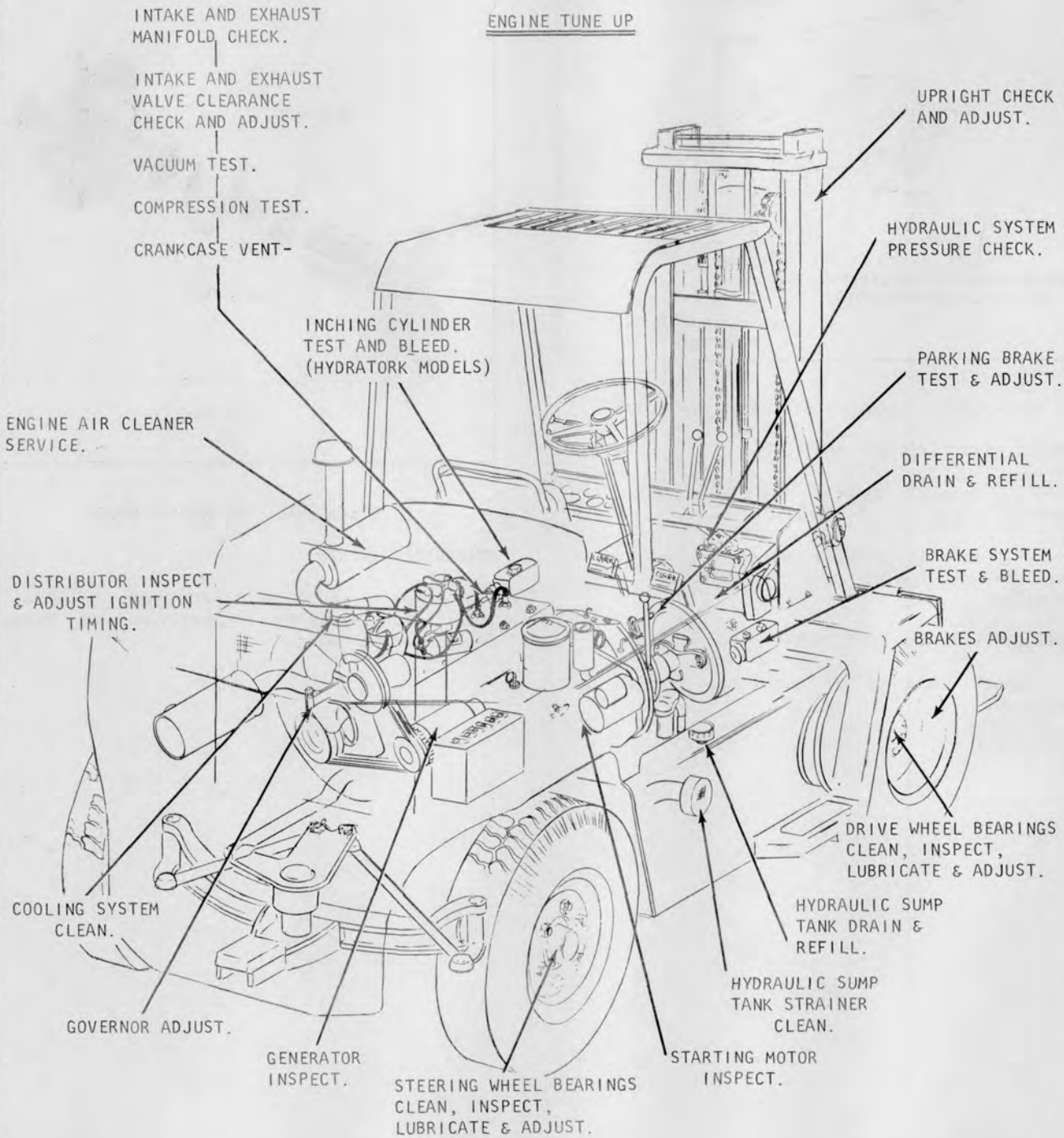

NOTE

IN ADDITION TO THE ABOVE, PERFORM THE 8 HOUR, 100
HOUR AND 500 HOUR PREVENTIVE MAINTENANCE SERVICES.

Plate 7709. Lubrication and Preventive Maintenance Illustration



Plate 7663. Typical Air Cleaner

ENGINE TUNE-UP

Engine tune-up is the orderly and systematic process of checking the engine and accessory equipment to maintain or restore satisfactory engine performance. Engine tune-up must be accomplished semi-annually and more frequently if engine performance indicates the need for these services. Perform engine tune-up as follows:

1. **AIR CLEANER.** Be sure air cleaner has received proper service. Air cleaner must be installed before making engine tune-up.
2. **FUEL PUMP.** Be sure the fuel pump bowl and strainer has been properly serviced and the fuel pump is operating satisfactorily.

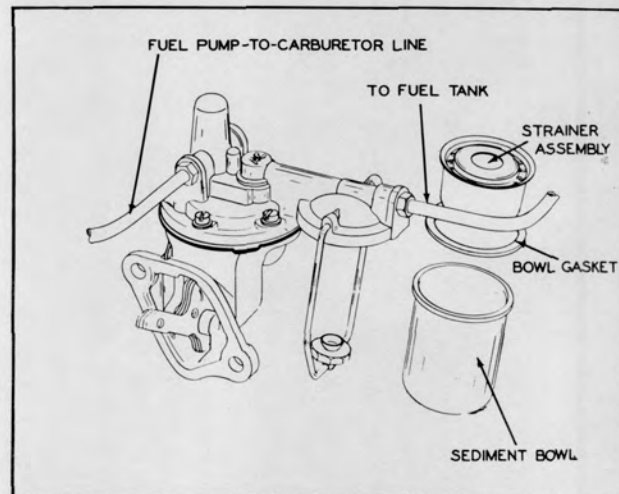

Plate 6432. Fuel Pump Strainer and Sediment Bowl

INDUSTRIAL TRUCK DIVISION

OPERATION AND MAINTENANCE

ENGINE TUNE-UP

1. Check the engine oil level and condition. If the oil is low, add the recommended grade of oil. If the oil is dirty, change it. Check the oil filter and replace it if necessary.

2. Check the air filter. If it is dirty, clean it or replace it. A clean air filter allows the engine to breathe and run smoothly.

3. Check the spark plug wires. Make sure they are in good condition and are properly connected to the spark plugs.

4. Check the spark plugs. Remove them and inspect them. Clean them if they are fouled. Replace them if they are worn.

5. Check the valve clearance. Adjust it if necessary. This is a more advanced task that may require a service manual.

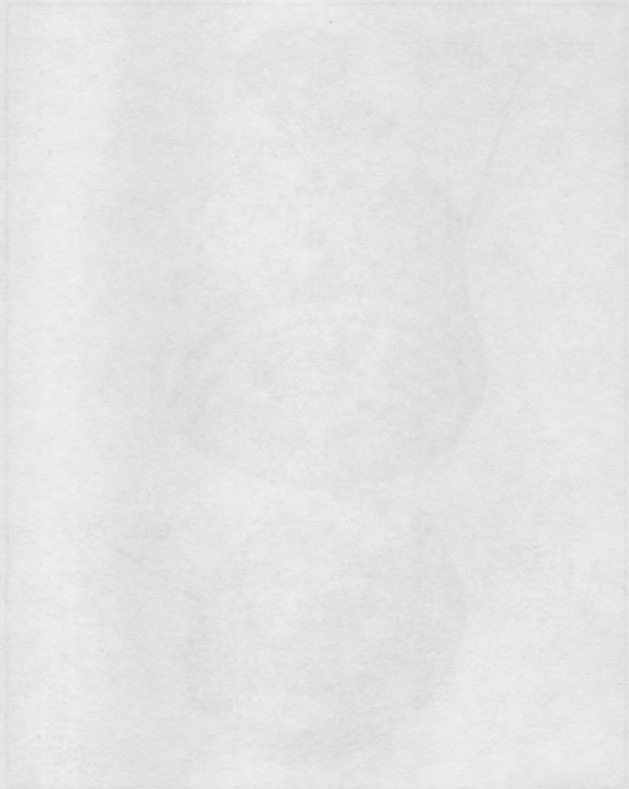

Always use the correct grade of oil and follow the manufacturer's recommendations for oil change intervals.

3. CYLINDER HEAD STUD NUTS. Check all stud nuts for correct torque, refer to specifications. Check cylinder head gasket for leaks.

CAUTION

THE SEQUENCE LISTED IN PLATE 5927. MUST BE FOLLOWED. ALL CYLINDER HEAD CAP SCREWS OR NUTS MUST BE TIGHTENED EVENLY AND TORQUED IN ACCORDANCE WITH LIMITS LISTED IN SPECIFICATIONS.

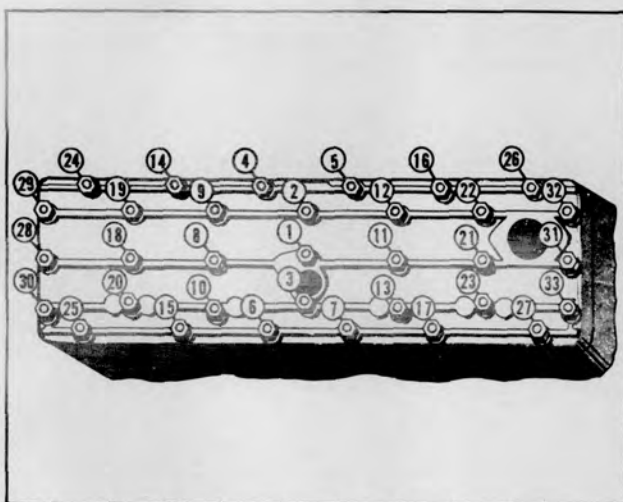

Plate 5927. Cylinder Head Stud Nut Tightening Sequence

4. INTAKE AND EXHAUST MANIFOLDS. Inspect for gasket leaks and security of mounting.

5. CRANKCASE VENTILATION METERING VALVE. The metering valve connected between the intake manifold and valve cover regulates the amount of air which will flow through the crankcase and is controlled by the engine vacuum.

Remove metering valve and disassemble and wash in a Stoddard type cleaning solvent. Before assembling, put a small quantity of very light oil on the metering pin to prevent sticking until its own lubrication is established. The ventilation tube and valve cover should also be cleaned at the same time, particularly if any noticeable amount of sludge accumulation is found.

After installing the metering valve on the engine be sure hose is in good condition and all connections are properly

sealed to prevent unfiltered air from entering the engine.



Plate 7034. Crankcase Ventilation Metering Valve

6. INTAKE AND EXHAUST VALVE CLEARANCE ADJUSTMENTS.

a. Remove valve chamber cover mounting screws, and the valve chamber cover gasket.

b. With engine running at idling speed and at normal operating temperature, adjust intake valves as follows:

c. Check for proper 0.014 inch clearance by alternately passing a 0.013 inch and a 0.015 inch flat feeler gauge between head of adjusting screw and valve stem, see Plate 3223 on following page.

d. If a 0.013 inch feeler gauge moves freely back and forth in gap when valve is not being lifted and a 0.015 inch feeler gauge binds, at all times, clearance requires no adjustment.

e. If a 0.013 inch feeler gauge is gripped at all times, the clearance is insufficient.

f. Hold valve lifter with an open end wrench while using a second wrench to turn adjusting screw 1/4 to 1/2 turn clockwise. Repeat clearance check and adjustment, until proper clearance is obtained. The adjustable type valve lifters

LUBRICATION AND PREVENTIVE MAINTENANCE

have self-locking adjusting screws that require no lock nuts.

g. If 0.015 inch feeler moves freely when valve is not being lifted, the clearance is too great. Hold valve lifter with an open end wrench while using a second wrench to turn valve lifter adjusting screw counterclockwise 1/4 to 1/2 turn. Repeat clearance check and adjustment until proper clearance is obtained.

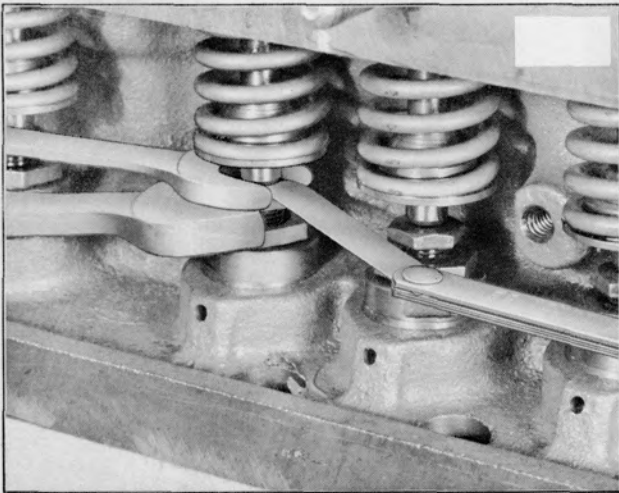

Figure 004a. Adjusting Valve Clearance

h. Repeat clearance check and adjustment on remaining intake valves.

i. With engine running at idling speed and at normal operating temperature, adjust exhaust valve as follows:

j. Check for proper 0.014 inch clearance by alternately passing a 0.013 inch and a 0.015 inch flat feeler gauge between head of adjusting screw and valve stem cap, see Figure 004a.

k. Follow procedure outlined in paragraphs (d) thru (h).

m. Install valve chamber cover using new valve chamber cover gasket and replace cover mounting screws.

NOTE

DO NOT REUSE OLD GASKETS. THEY DO NOT AFFORD A POSITIVE SEAL.

n. Check valve chamber cover gasket for leaks.

7. COMPRESSION TEST

a. Test battery for full charge (specific gravity 1.280 temperature of 24°C (75° F). If battery is not fully charged, replace with fully charged battery.

b. Start engine and allow it to warm up until normal operating temperature is reached.

c. Turn off ignition.

d. Remove spark plug cables from spark plugs and remove spark plugs from cylinder head. Examine spark plugs for carbon deposits, defective insulation and general serviceability. All carbon or lead deposits must be removed from the insulation shell and electrodes. This can be done on a sand blast cleaner. Carbon deposits should be removed from the plug threads with a stiff brush. After cleaning, inspect plugs carefully for cracked or broken insulator, badly pitted electrodes or other signs of failure.

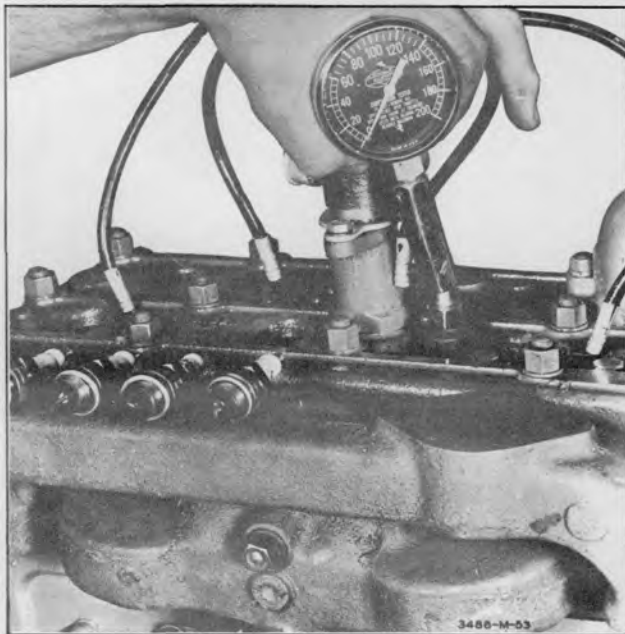

Plate 3486. Compression Test

e. With all plugs removed, install compression gauge in front spark plug port. Operate starting motor until maximum reading on gauge is obtained, see Plate 3486. Record gauge reading. Repeat this operation on each remaining cylinder.

f. If readings are reasonably high (110 to 120) pounds and the readings do not vary more than about 10 pounds between cylinders, compression may be considered normal. Excessively low readings or readings that vary more than 10 pounds between cylinders indicate internal trouble to be corrected after further examination and testing.

g. Set the spark plug gap as specified, by bending side electrode only. The gap should be checked with a wire feeler gauge rather than a flat type gauge as it is better suited for this purpose.

h. Spark Plug Specifications:

- Standard Type - .025" Gap
- Resistor Type - .035" Gap

i. Replace spark plugs using new gaskets. Always replace spark plug gasket whenever a spark plug is removed from the engine. Before installing plugs, be sure that the spark plug seat in the cylinder head is clean and free from obstructions. The spark plug should be screwed into cylinder head (using a socket of proper size) sufficiently tight to fully compress the gasket. This is most important as a large percentage of troubles due to overheated spark plugs are caused by plugs being too loose in the cylinder head. Conversely, excessive tightening may change the gap between the electrodes or crack the insulator.



Plate 3278. Check Spark Plug Gap

INDUSTRIAL TRUCK DIVISION



Faint, illegible text in the upper left section of the page.

Faint, illegible text in the upper right section of the page.

Faint, illegible text in the middle left section of the page.

Faint, illegible text in the middle right section of the page.

Faint, illegible text in the lower middle left section of the page.

Faint, illegible text in the lower middle right section of the page.

Faint, illegible text in the lower left section of the page.

Faint, illegible text in the lower right section of the page.

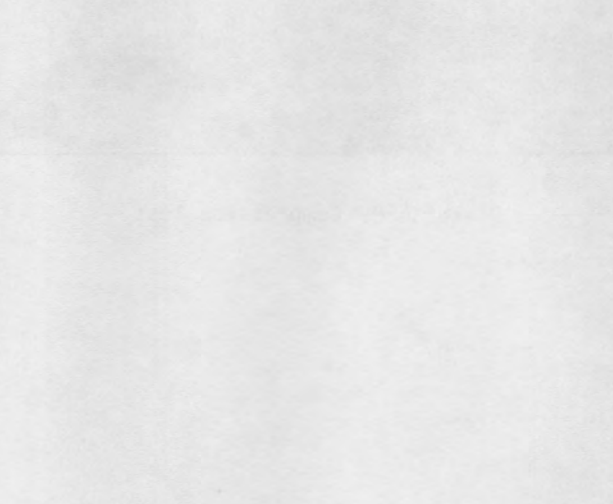
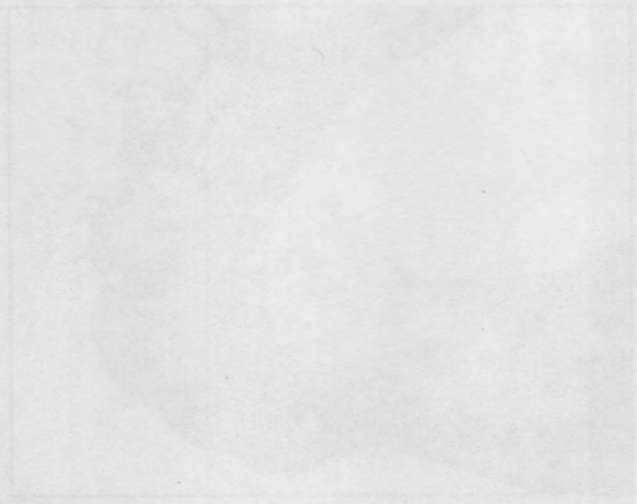

8. DISTRIBUTOR

Inspection: Remove distributor cap (without removing wires). Wipe cap with a clean cloth. Examine rotor and cap for chips, cracks, corroded terminals, carbon runners (paths which will allow high-tension leakage to ground) or if the vertical faces of the inserts are burned -- install a new cap and rotor, as this is due to the rotor being too short.

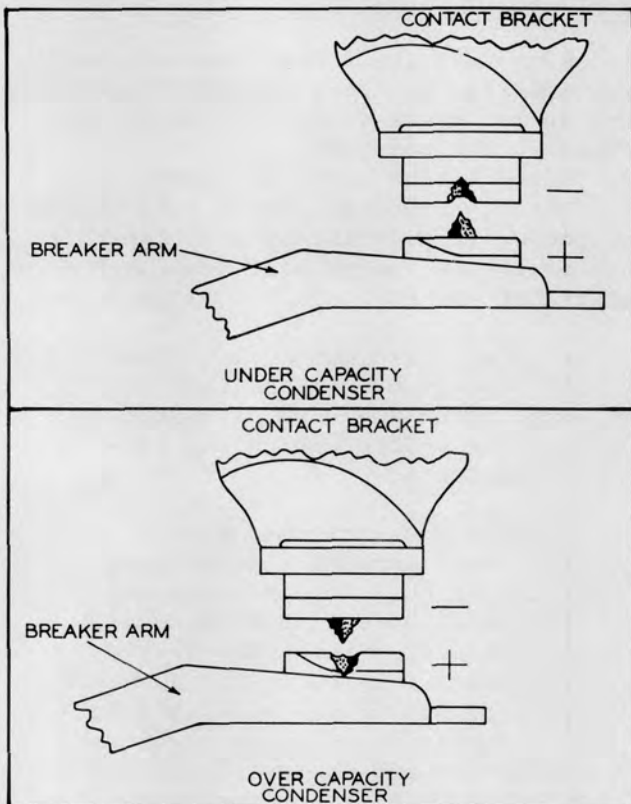

Plate 5933. Breaker Points

Check the centrifugal advance mechanism for "freeness" by turning the breaker cam in the direction of rotation and then releasing it. The advance springs should return the cam to its original position without sticking.

Inspect breaker points. If points are pitted, burned or worn to an unserviceable condition, install a new set of points.

The normal color of contact points should be a light gray. If the contact point surfaces are black, it is usually caused by oil vapor, or grease from the cam. If they are blue, the cause is usually excessive heating due to improper

alignment, high resistance or open condenser circuit.

Badly pitted points may be caused by a defective or improper condenser capacity.

If the condenser capacity is too high, the crater (depression) will form in the positive contact. If the condenser capacity is too low, the crater will form in the negative contact, see Plate 5933.

For a temporary repair, dress the contact points with a few EVEN strokes using a clean fine-cut contact file. DO NOT ATTEMPT TO REMOVE ALL ROUGHNESS OR DRESS THE POINT SURFACES DOWN SMOOTH. See Plate 7475.

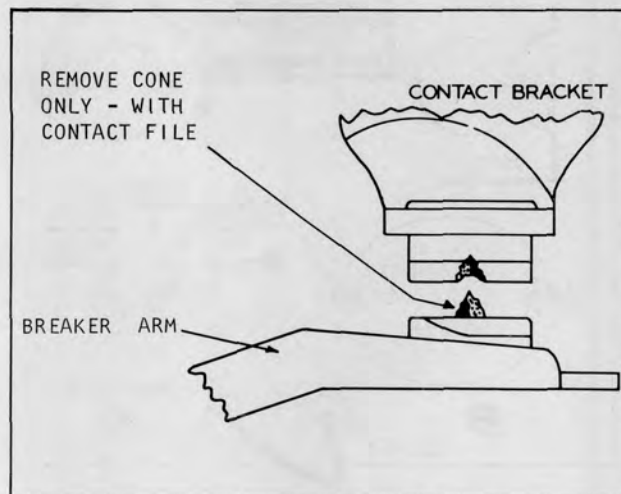
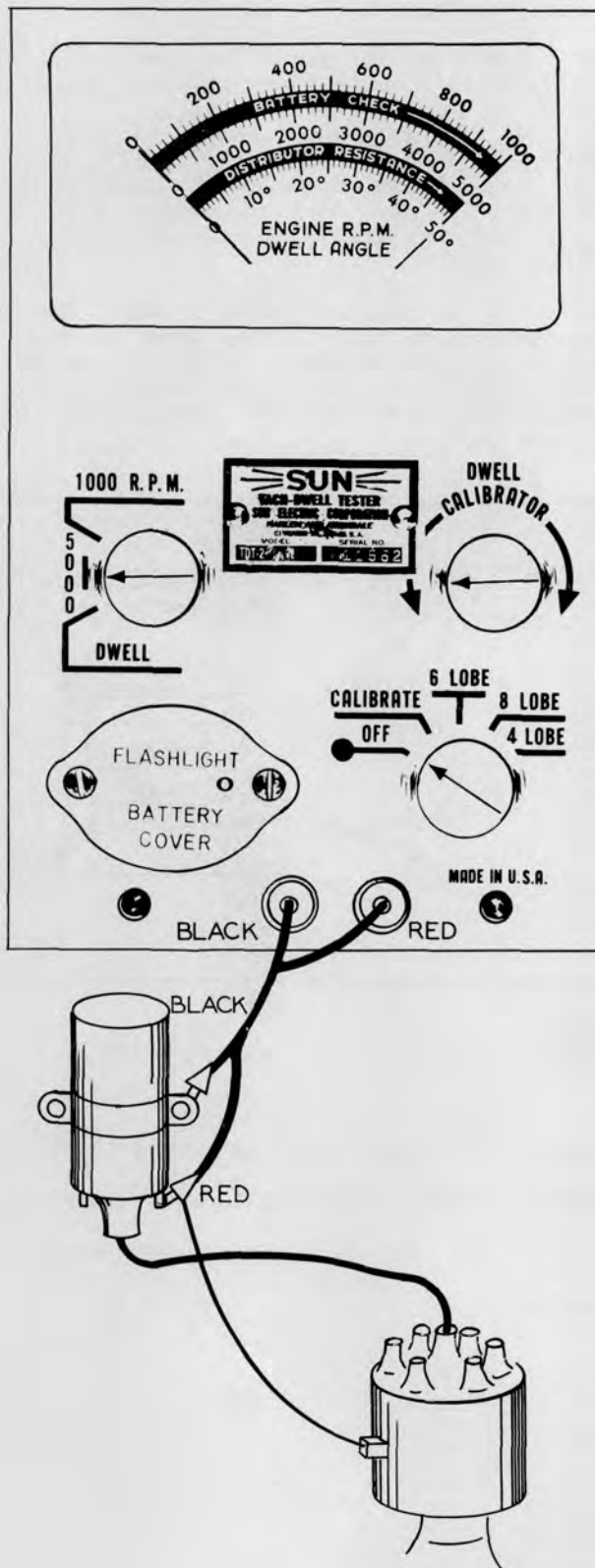

Plate 7475. File Contact Points

CAUTION

NEVER USE EMERY CLOTH OR SANDPAPER TO CLEAN POINTS AS PARTICLES WILL EMBED IN THE POINTS AND CAUSE ARCING AND RAPID BURNING.



MEASURING ENGINE SPEED

1. Connect the test leads as shown.
2. Turn switch to the LOBE position corresponding to the number of cylinders.
3. Turn the other switch to the 1000 rpm position for all idle and low speed testing. Use the 5000 rpm position for all speeds over 1000 rpm.

DISTRIBUTOR RESISTANCE TEST

1. With test leads disconnected, turn switches to DWELL and CALIBRATE positions and adjust dwell calibrator until meter reads on the SET LINE.
2. Connect test leads as shown.
3. Turn ignition switch ON with engine stopped. If distributor resistance is not excessive, meter will read in the black bar marked DISTRIBUTOR RESISTANCE.

If meter does read within black bar, readjust dwell calibrator until meter again reads on the SET LINE before making the following tests.

If meter does not read within black bar, excessive resistance is indicated. To locate excessive resistance, trace the primary circuit through the distributor with the red test lead until point of high resistance is located. Excessive resistance must be eliminated and the dwell calibrator adjusted until the meter again reads on the SET LINE before proceeding with the following tests.

DWELL AND DWELL VARIATION TESTS

1. Turn switch to the proper LOBE position.
2. Operate engine at idle speed and note reading on dwell scale of meter. Refer to specifications for proper dwell.
3. Turn tachometer switch to the 5000 rpm position and increase speed to 1500 rpm.
4. Turn switch back to the DWELL position and again note dwell reading. Slowly reduce speed to idle while watching meter. Dwell should not change more than 3 degrees in either case.

Contact Point Adjustment: The point opening of new points can be checked with a wire feeler gauge, but the use of a feeler gauge on older, rough points is not recommended, since accurate gauging cannot be done on such points. The gauge measures between high spots on the points instead of the true point opening. Point opening of used points can be checked with a Dwell Angle Meter. A meter of this type indicates the cam or contact angle. This angle is the number of degrees that the breaker cam rotates from the time the points close until they open again. The cam angle increases as the point opening decreases and it is reduced as the point opening is increased. Manufacturers of this type equipment furnish complete instructions as to their use.

NOTE
REFER TO SPECIFICATIONS FOR DWELL ANGLE AND CONTACT POINT OPENING.

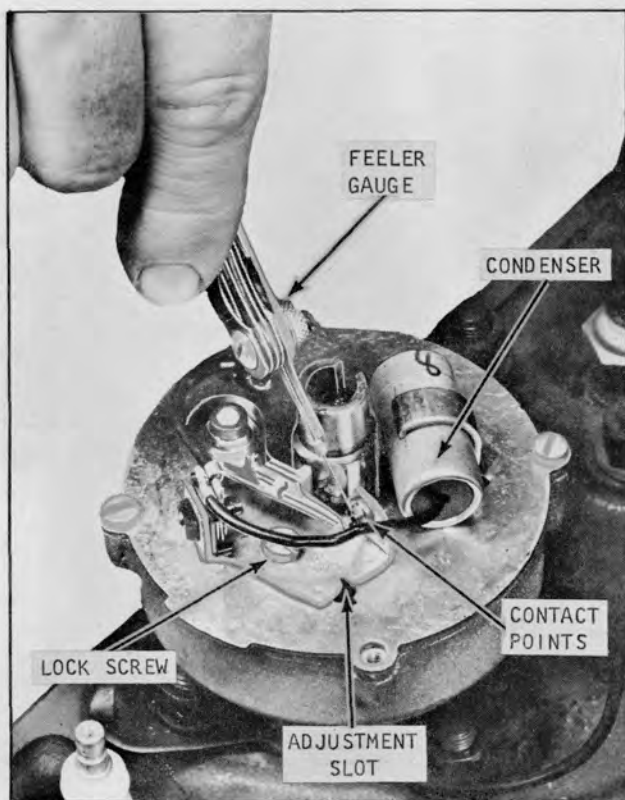

Plate 7457. Contact Point Adjustment
To check point opening with a feeler gauge, insert a wire feeler gauge of proper size between the contact points. MAKE CERTAIN THAT THE BUMPER BLOCK ON THE MOVABLE CONTACT IS AT THE HIGH POINT ON THE CAM. If adjustment is necessary, loosen the lock screw, and insert a screw driver of

the proper size in the adjustment slot and move the stationary arm until the correct clearance is obtained. Tighten locking screw and recheck point gap. See Plate 7457.

9. IGNITION TIMING

- If the engine is out of time, the following procedure should be followed:
- Remove No. 1 spark plug which is the one nearest the radiator.
 - Press thumb over hole left vacant by removal of the spark plug.
 - With thumb pressed over hole, Plate 3471, turn engine over slowly with the starter until air is being forced up around the thumb.
 - Stop turning engine over at this point for it means that No. 1 piston is on the compression stroke and it is approaching top dead center.



Plate 3471. Ignition Timing

- Flash a light into the timing hole and continue to turn engine over slowly until the top dead center marking on flywheel appears in timing hole, Plate 3471.
- The pointer (Plate 3471) should be centered on the top D.C. marking.
- With breaker points set at proper gap, loosen distributor clamp plate screw and rotate distributor body until the contact points just start to open. This may be more accurately checked by means of a test lamp connected between the distributor primary lead and a ground. When points are closed the light will be "ON" and as soon as the points break the light will go "OFF". Tighten clamp plate screws before starting engine.

INDUSTRIAL TRUCK DIVISION

INDUSTRIAL TRUCK DIVISION

Faint, illegible text, likely bleed-through from the reverse side of the page.

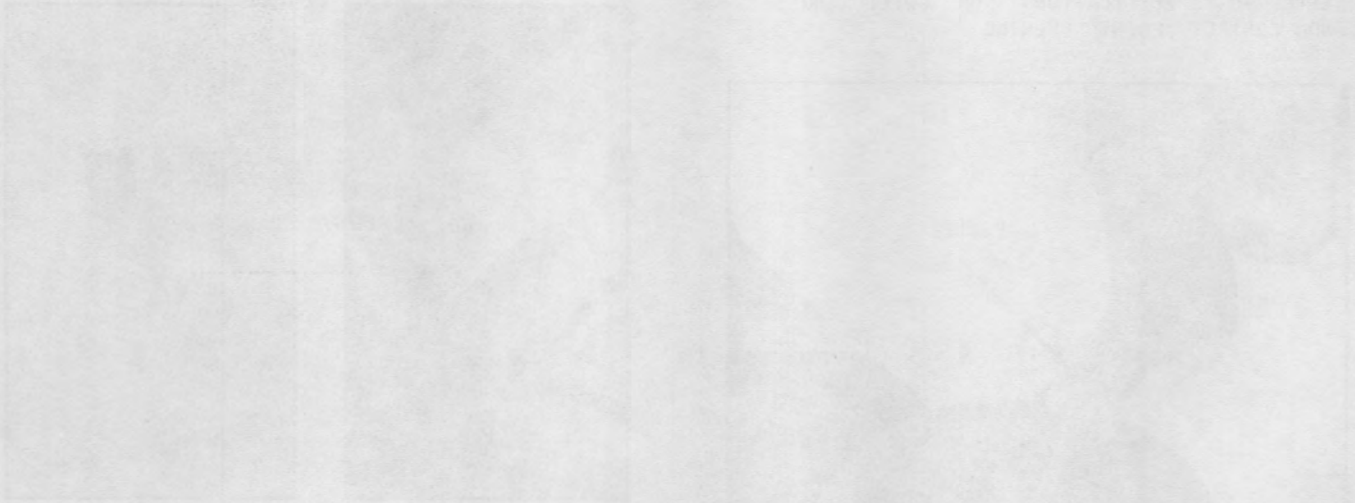

Faint, illegible text, likely bleed-through from the reverse side of the page.

10. VACUUM TEST

Before making vacuum test, make certain cylinder head is securely tightened and that cylinder head gasket is not leaking. Air cleaner must be installed and must be clean to perform vacuum test. Manifold stud nuts must be tight and there must not be any leakage at gasket.

Remove vacuum pipe plug from intake manifold or carburetor (machines so equipped) and attach vacuum gauge in pipe plug opening. Start engine and allow it to warm up to normal operating temperature.

Idle Fuel Adjustment: The idle adjustment needles regulate the fuel-air mixture, see Plate 6447 and 6448. Turning the screws clockwise, towards the seat, cuts off air increasing the suction on the idle jet and making the mixture richer. Turning the idle adjusting screws counterclockwise, or away from seat, allows more air to be mixed with the fuel making a leaner mixture for idling.

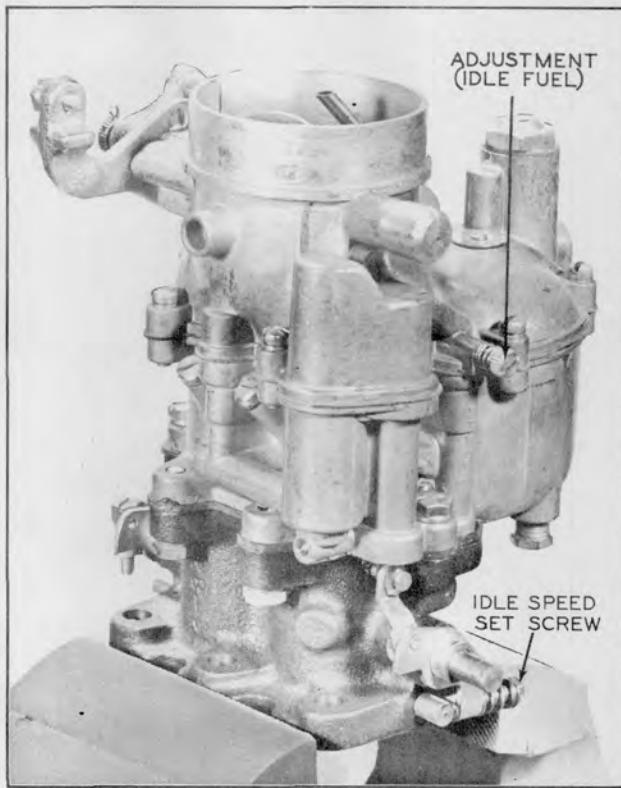

Plate 6447. Idle Fuel Adjustment

Turn the screws until highest vacuum reading is obtained.

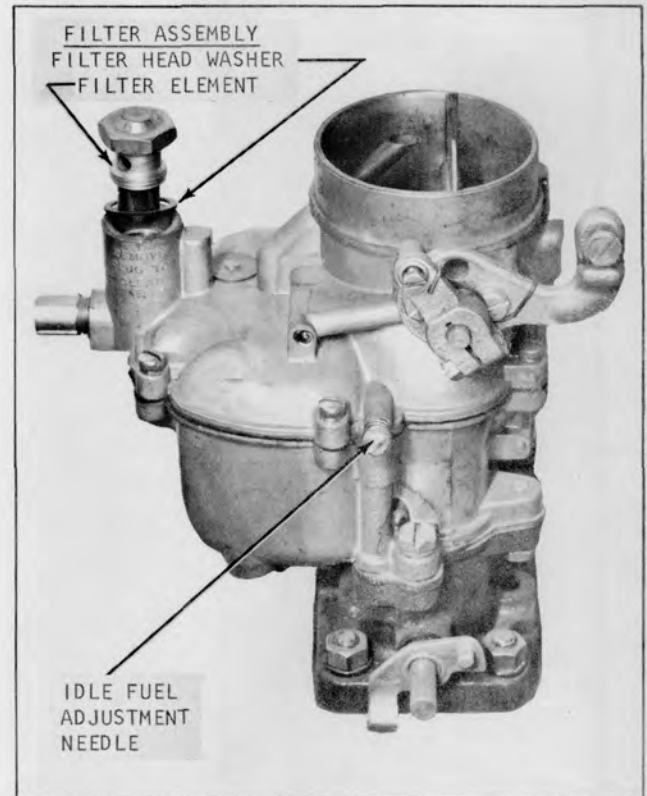

Plate 6448. Idle Fuel Adjustment and Filter Assembly

If a gauge is not used, set the screws to a range at which engine idles its smoothest.

Idle Speed Adjustment: A stop screw controls action of the throttle valve. Turn screw clockwise for faster idle speed, or counterclockwise for slower idle speed. This adjustment should be made with a tachometer. Idling speed should be set for 450 to 500 revolutions per minute. Reset idle fuel needle screw if necessary, after throttle adjustment has been made.

Carburetor Fuel Filter: Remove Fuel Filter Assembly, see Plate 6448. Clean or replace as required. Check Filter Head Washer for serviceability before reassembling filter to carburetor.



INDUSTRIAL TRUCK DIVISION

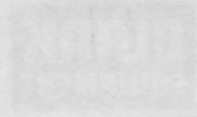

Faint text or header information below the main title.

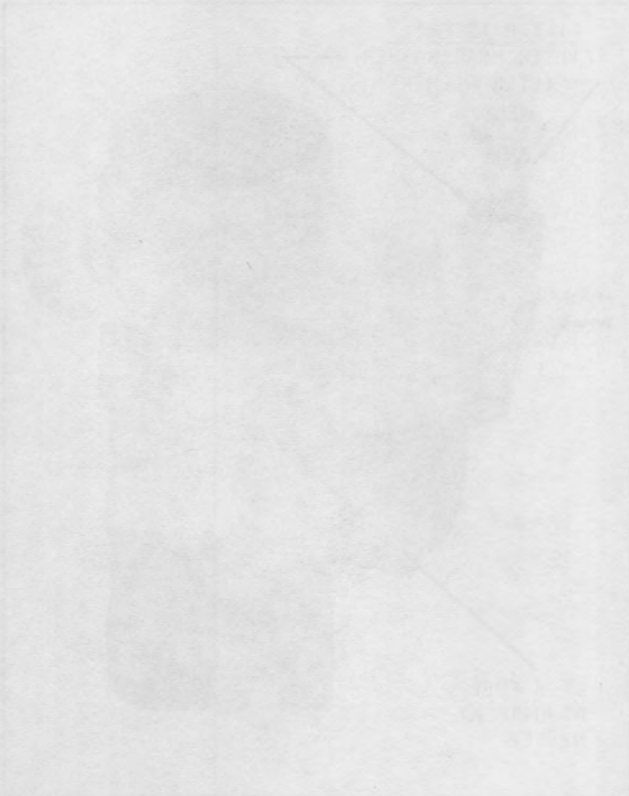

Multiple paragraphs of faint text, likely technical specifications or a description of the product shown in the diagram.

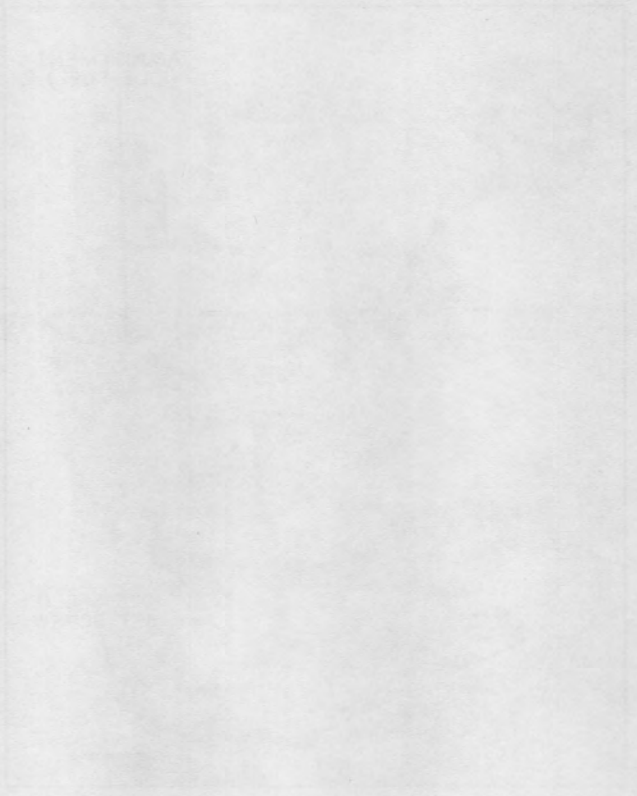

Additional paragraphs of faint text at the bottom left, possibly related to the technical drawings.



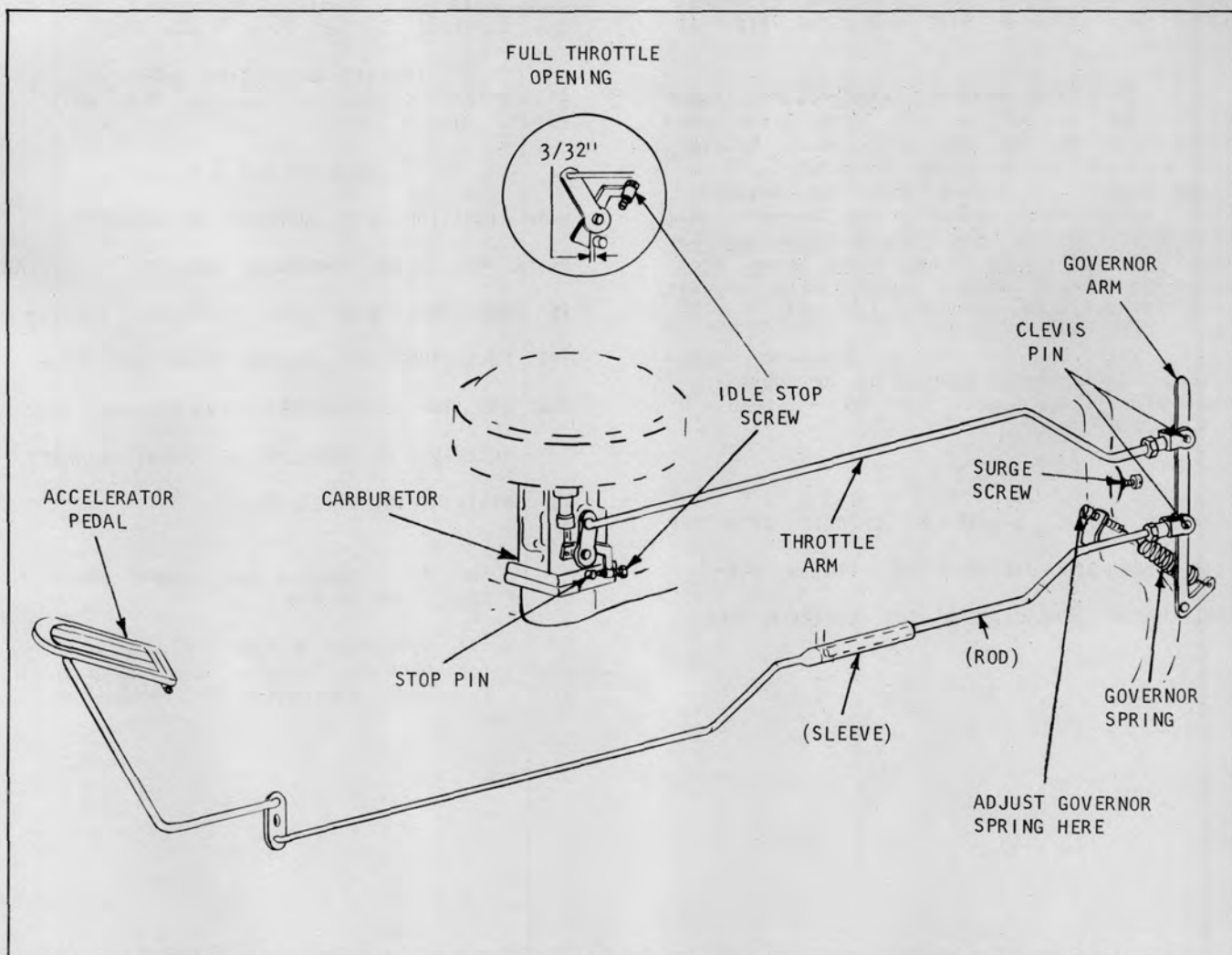

Plate 7658. Governor Adjustment

11. GOVERNOR ADJUSTMENT (GAS ENGINES)

NOTE

With timing set on top dead center, and the carburetor properly adjusted to idle at 500 R.P.M., proceed with the following:

THE SLIP TUBE ROD AND SLEEVE ASSEMBLY CANNOT FUNCTION PROPERLY IF IT IS BINDING, THEREFORE, THE ASSEMBLY MUST BE CLEAN AND PROPERLY LUBRICATED TO CORRECTLY ADJUST THE GOVERNOR.

A. Loosen Governor Surge Screw Jam Nut and back Surge Screw out.

B. Disconnect Slip Tube Rod from Governor Arm by removing Clevis Pin.

D. With the Slip Tube and Sleeve Assembly disconnected, the Governor Arm will move forward. Check the Carburetor Throttle Opening Stop and Stop Pin on the carburetor.

NOTE

REMOVE CLEVIS PIN --- DO NOT LOOSEN CLEVIS JAM NUT.

C. Pull rod from Slip Tube Sleeve and thoroughly clean rod and sleeve. Lubricate rod with Graphite Grease after cleaning.

If adjustment is necessary, adjust the Throttle Rod between carburetor and



INDUSTRIAL TRUCK DIVISION



LUBRICATION AND PREVENTIVE MAINTENANCE

governor arm until the specified clearance (3/32 inch between STOP and STOP PIN) is obtained.

E. Push the Governor Arm toward rear of machine until the Idle Stop Screw contacts Stop Pin on the carburetor. Rotate the Governor Surge Screw inwards until screw comes in contact with the Governor Shaft Lever (when holding the Governor Arm rearward) ---- Do Not Rotate Screw So Far That The Idle Stop Screw Moves Away From Stop Pin. When correct surge screw adjustment is obtained, tighten jam nut.

F. With the use of an Electric Tachometer, start engine (Warm up to normal temperature) and check for NO -- LOAD 2600 R.P.M.

NOTE

GOVERNED R.P.M. SHOULD BE CHECKED WITH THE SLIP TUBE ROD DISCONNECTED BETWEEN THE ACCELERATOR LINKAGE AND THE GOVERNOR ARM.

If adjustment is necessary, adjust the Governor Spring, see Plate 7658.

G. Install Slip Tube over rod. Attach Rod Clevis to Governor Arm with Clevis Pin.

IMPORTANT

WITH IGNITION OFF, DEPRESS ACCELERATOR PEDAL AND CHECK THROTTLE OPENING. IF THERE IS MORE THAN 3/32 INCH CLEARANCE BETWEEN THE FULL THROTTLE OPENING STOP AND STOP PIN (ON THE CARBURETOR), ADJUST THE SLIP TUBE CLEVIS, OR ACCELERATOR PEDAL LINKAGE TO OBTAIN THIS DIMENSION.

H. Start engine and again check for NO - LOAD 2600 R.P.M.

If specified R.P.M. is not obtained, check for binding linkage, bent Slip Tube, etc., free up, straighten or repair as required.

STARTING MOTOR

1. Remove end plate (or Brush Cover) from starter. Use a wire hook to lift a brush spring and remove brush from holder. Compare brush size with that of a new brush. If brush is worn beyond half the original size, or if brushes are jammed, chipped, or broken they must be replaced.

CAUTION

NEVER ALLOW SPRING TO SNAP DOWN ON BRUSHES.

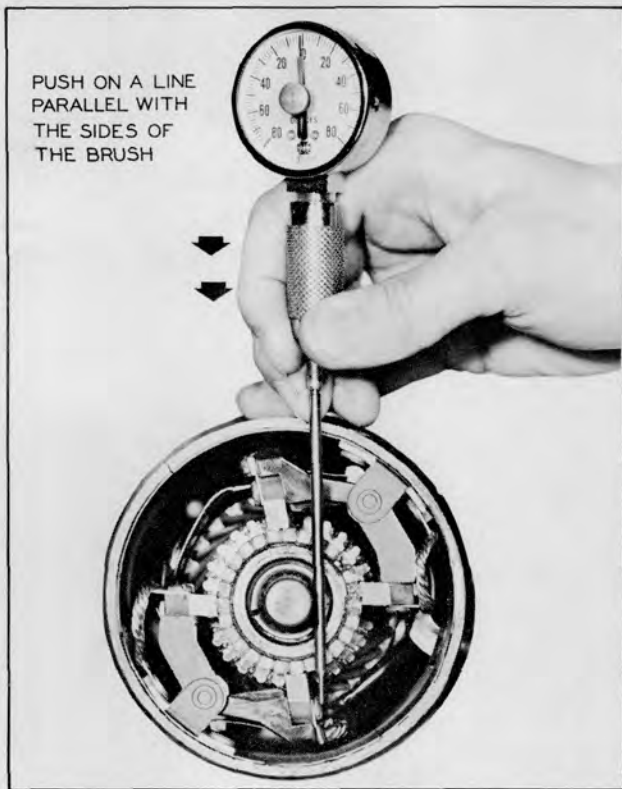

Plate 6449 Checking Brush Spring Tension

2. Check for Brush Spring Tension, refer to Specifications. Refer to the following procedures for checking spring tension.

Measuring Brush Spring Tension - Reaction Type Brushes. Hook the scale under the brush spring near the end and push or pull on a line parallel to the sides of the brush. To assist in telling the exact instant that the pressure is relieved, a small strip of paper can be placed under the brush. Pull slightly on the paper and the paper will slip out at the correct instant for reading the spring scale.

Measuring Spring Tension - Swinging Type Brushes: Hook the spring scale under the brush screw tight

against the brush and push or pull on a line parallel to the sides of the brush. Take the reading just as the brush leaves the commutator. Pulling slightly on a strip of paper which has been placed under the brush will indicate when the brush leaves the commutator and the correct instant for reading the spring scale.

3. If commutator is glazed or dirty, clean with a strip of No. 00 sandpaper. Blow out all dirt and grit with compressed air.

CAUTION

DO NOT USE EMERY CLOTH TO CLEAN COMMUTATOR.



Plate 6450. Checking Brush Spring Tension

Condition Test: Use one of the two following methods to determine whether the starting motor should be removed from the engine for inspection, service or replacement.

1. First Method: Operate the starting motor by disconnecting the battery cable from the solenoid switch and holding the cable terminal firmly against the starting motor terminal, using a battery known to be fully charged and in good condition. To do this it will be necessary to remove the solenoid switch.

2. If the motor reacts correctly, and the drive mechanism engages and disengages each time the starting motor is operated, the starting motor is in good condition.

3. If motor does not react properly, it must be removed for inspection or replacement.

4. Second Method: Using a voltmeter and a battery (fully charged) that is in good condition, connect positive lead of test voltmeter to positive terminal of battery and negative lead of voltmeter to negative (grounded) terminal of battery. Record voltmeter reading. Now pull high-tension wire from ignition coil so engine will not start when starter is engaged. Connect positive lead of test voltmeter to ground and negative lead of test voltmeter to starter switch terminal. Turn ignition switch to start position and note voltmeter reading. Compare this reading with the previously recorded reading. If the voltage drop is more than 4 volts, or if the second reading is below 8 volts, the starting motor should be removed from the engine for further testing and repair, or replacement.

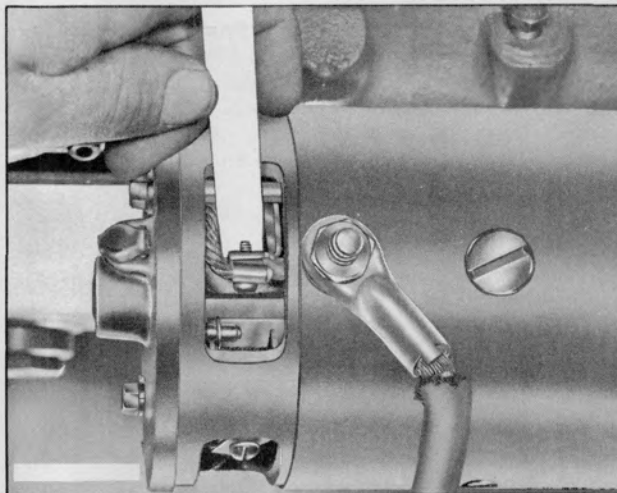

Plate 3436. Seating Brushes

NOTE

BLOW OUT ABRASIVE PARTICLES AFTER SEATING BRUSHES.

GENERATOR

1. Remove end plate (or Brush Cover) from generator. Use a wire hook to lift a brush spring and remove brush from holder. Compare brush size with that of a new brush. If brush is worn beyond half the original size, or if brushes are jammed, chipped, or broken they must be replaced.

CAUTION

NEVER ALLOW SPRING TO SNAP DOWN ON BRUSHES.

New brushes can be seated with a brush seating stone. When held against the revolving commutator, the abrasive material carries under the brushes, seating them in a few seconds. Blow out abrasive particles after seating brushes. See Plate 3436.

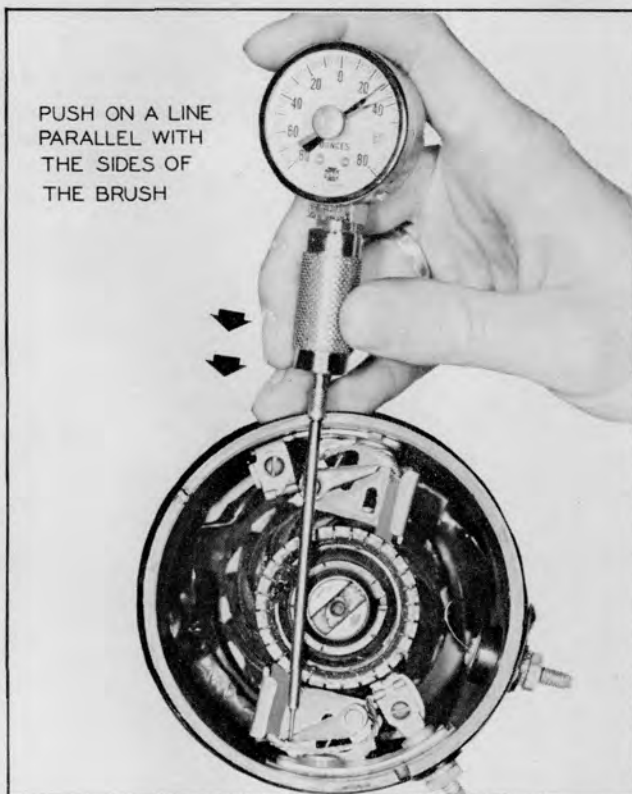

Plate 6451. Checking Brush Spring Tension

Using a spring scale, check for proper brush spring tension. Refer to Specifications. Refer to the following procedures for checking spring tension.

Measuring Brush Spring Tension - Reaction Type Brushes. Hook the scale under the brush spring near the end and push or pull on a line par-

allel to the sides of the brush. To assist in telling the exact instant that the pressure is relieved, a small strip of paper can be placed under the brush. Pull slightly on the paper and the paper will slip out at the correct instant for reading the spring scale.

Measuring Spring Tension - Swinging Type Brushes:

Hook the spring scale under the brush screw tight against the brush and push or pull on a line parallel to the sides of the brush. Take the reading just as the brush leaves the commutator. Pulling slightly on a strip of paper which has been placed under the brush will indicate when the brush leaves the commutator and the correct instant for reading the spring scale.

3. If commutator is glazed or dirty, clean with a strip of No. 00 sandpaper. Blow out all dirt and grit with compressed air.

CAUTION

DO NOT USE EMERY CLOTH TO CLEAN COMMUTATOR.

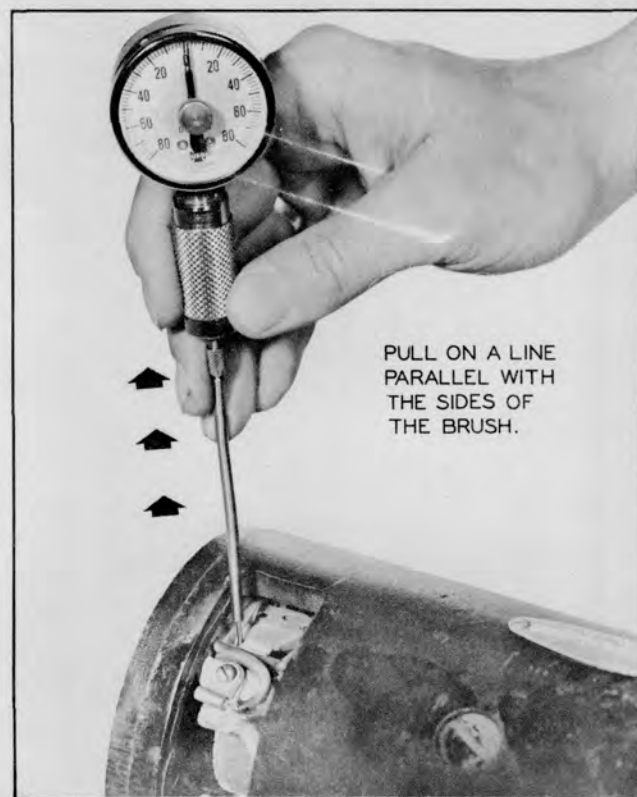

Plate 6450. Checking Brush Spring Tension

NOTE

BLOW OUT ABRASIVE PARTICLES AFTER SEATING BRUSHES.

REGULATOR

Inspect regulator leads for frayed or worn condition. Check to make certain that leads are tight and securely mounted.

WIRING

Check all wires for loose or corroded connections and for fraying. Replace defective wires.

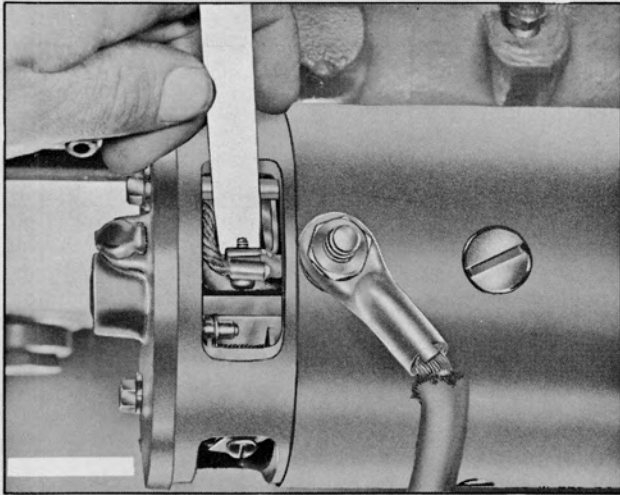

Plate 3436. Seating Brushes

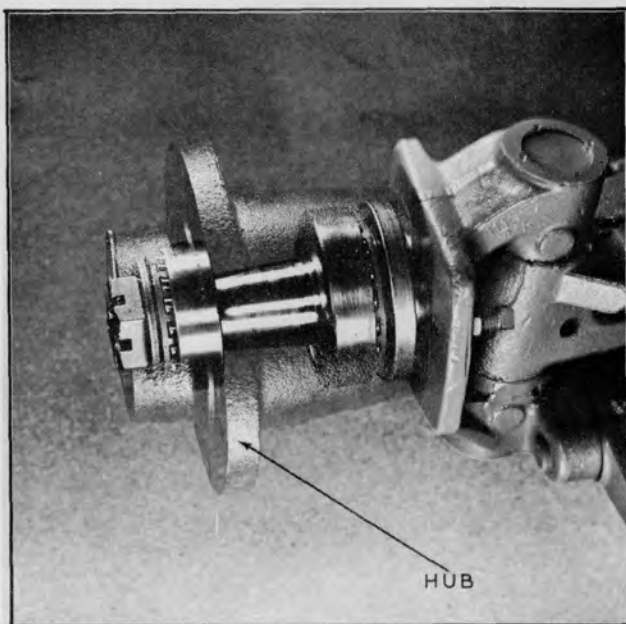

Plate 6705. Typical Wheel Bearings

STEERING WHEEL BEARINGS

Adjustment:

1. Raise rear of machine so that tires clear floor.

WARNING

AFTER RAISING MACHINE AND BEFORE MAKING ANY ADJUSTMENTS OR ADJUSTMENT CHECKS, PLACE ADEQUATE (HEAVY) BLOCKING (SUFFICIENT TO SUPPORT THE WEIGHT OF THE MACHINE) UNDER THE FRAME TO PREVENT ACCIDENTAL LOWERING OR FALLING OF THE VEHICLE, THUS PREVENTING PERSONAL INJURY TO MECHANIC OR BYSTANDERS.

2. Inspect adjustment of bearings by gripping top and bottom of tire, chuck tire 'in' and 'out' to determine looseness or wobble.

NOTE

BEFORE MAKING WHEEL BEARING ADJUSTMENTS, BE SURE PLAY (LOOSENESS OR WOBBLE) IS IN THE WHEEL BEARINGS AND NOT IN THE KING PINS.

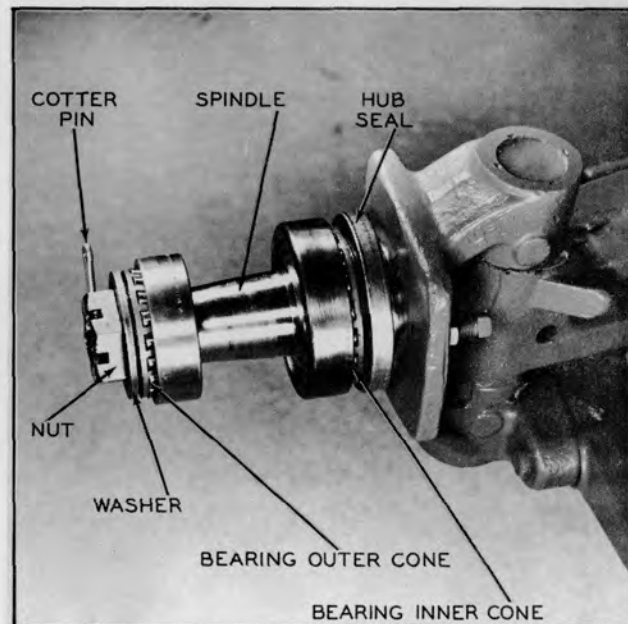

Plate 6703. Typical Wheel Bearings

NOTE

IF WHEEL BEARINGS NEED ADJUSTING, CLEAN AND REPACK BEARINGS BEFORE MAKING ADJUSTMENTS. REFER TO LUBRICATION PARAGRAPH. BEFORE REPACKING WHEEL BEARINGS, CHECK FOR ANY INDICATION OF LEAKAGE AROUND HUB SEALS. IF SUCH A CONDITION EXISTS, REPORT TO DESIGNATED PERSON IN AUTHORITY.

3. If looseness or wobble is in the wheel bearings, remove hub cap and spindle cotter pin, see (Plate 6703.) Tighten nut with a 12" wrench, and at the same time rotate the wheel in one direction and then in the other until there is a slight bind to be sure all bearing surfaces are in contact. Then back off the nut 1/6 to 1/4 turn allowing the wheel to rotate freely. Secure nut at this position with a new cotter pin and replace hub cap.

Lubrication:

1. Remove wheels after 1000 hours or every six months of operation. Clean bearings and repack with medium bodied high temperature wheel bearing grease, Clark Specification MS9C.
2. Install wheels and adjust wheel bearings as previously described.

INDUSTRIAL TRUCK DIVISION

INDUSTRIAL TRUCK DIVISION

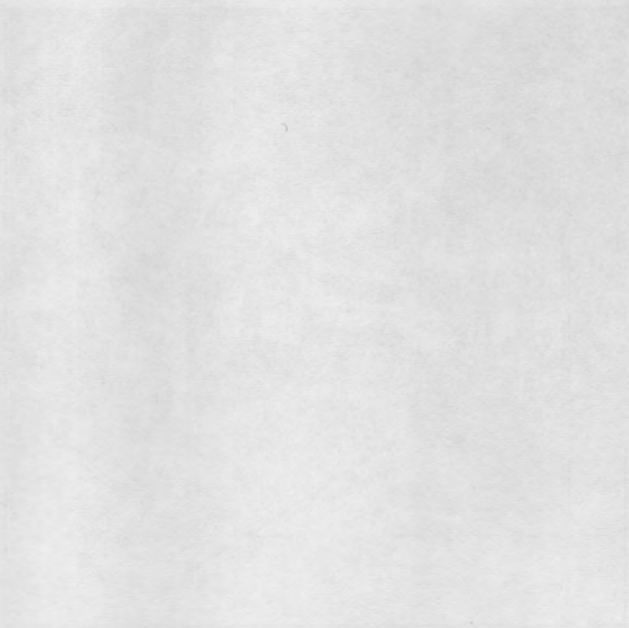
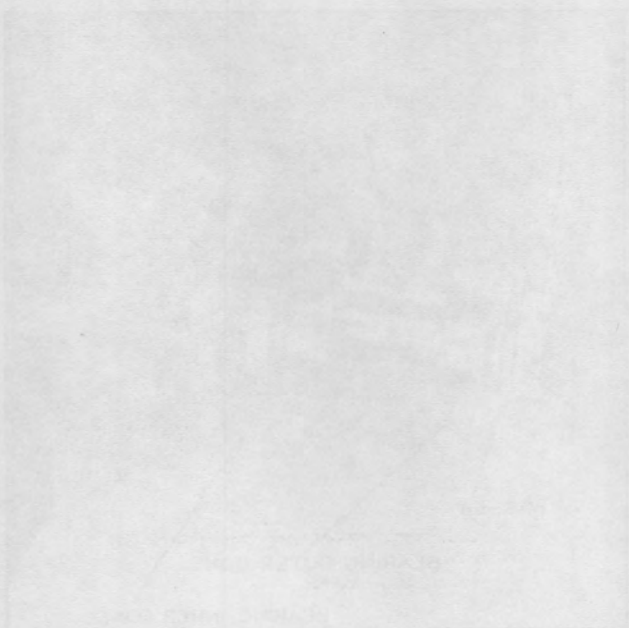

Faint, illegible text in the bottom left quadrant, possibly bleed-through from the reverse side of the page.

Faint, illegible text in the bottom right quadrant, possibly bleed-through from the reverse side of the page.

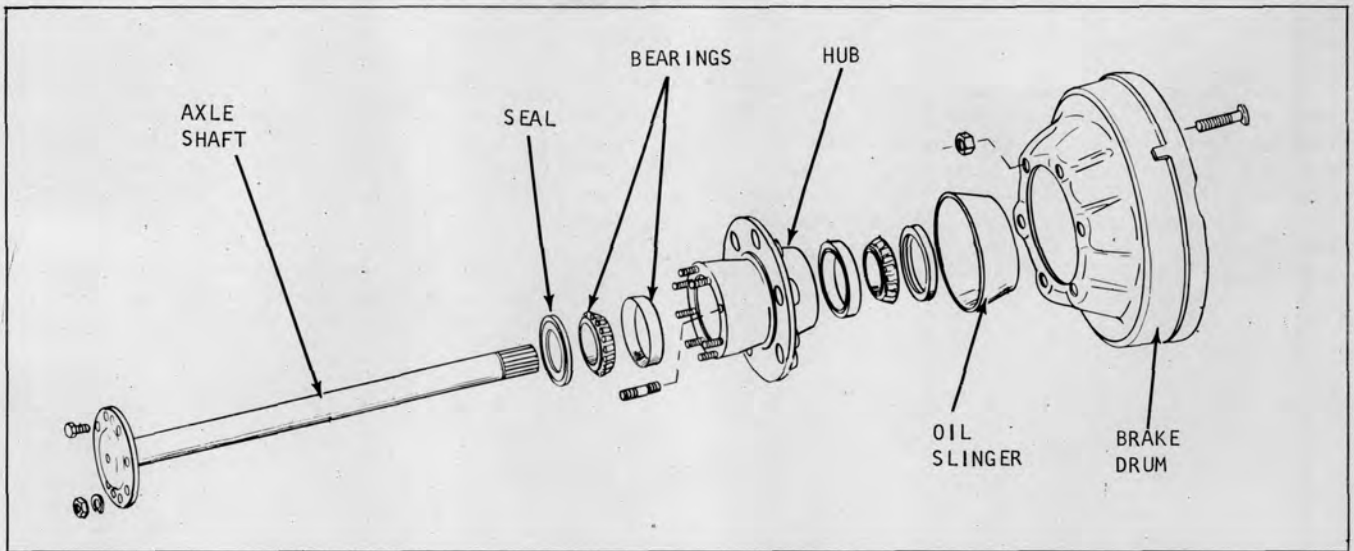

Plate 7102. Axle Shaft and Hub Assembly

CLEAN AND REPACK DRIVE WHEEL BEARINGS

Every 1000 operating hours remove and repack the drive wheel bearings with AMOCO Lithium multipurpose grease, Shell Alvania EP #1 or equivalent.

1. Tilt upright back. Place solid heavy blocks under each upright rail. Tilt upright forward until vertical. This should allow the drive wheels to clear the ground. Deflate the tires and remove the wheels from the hub assembly.

2. Remove the screws that retain the axle shaft to the hub. By using jack screws in the holes provided in the axle flange, the axle may be pulled.

3. Unclinch the tube nut lock and remove the outer tube nut, nut lock and inner tube nut.

4. The hub and drum assembly may now be removed from the axle tube.

5. Remove the brake drum oil slinger, inner and outer seals from the hub and lift out the bearing cones.

6. Clean the hub assembly and bearings in separate containers using a Stoddard type cleaning solvent. After all solidified particles of lubricant are removed from the bearings blow dry with compressed air. Direct air stream across bearings to prevent spinning. Slowly rotate bearing by hand to facilitate drying. Inspect bearings and races carefully to

determine if they are in good condition and suitable for further service. Dry the hub assembly with compressed air.

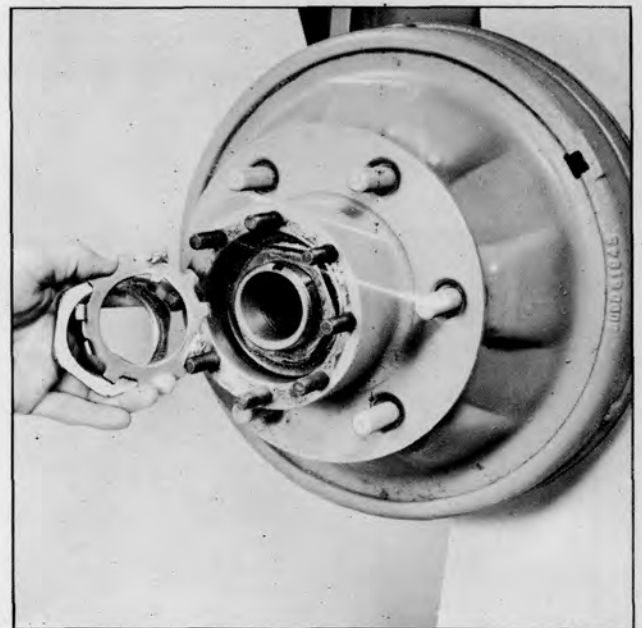

Plate 7103. Axle Tube Nuts and Nut Lock

7. Repack bearing cones with the type grease previously described and install in hub assembly. If there is any doubt about the serviceability of the bearing seals it is more economical to install new ones to prevent a premature overhaul to replace these parts at a future time. Care should be taken when installing the hub over the axle tube to prevent damage to the seals.



INDUSTRIAL TRUCK DIVISION



LUBRICATION AND PREVENTIVE MAINTENANCE

Cutting, scratching or curling under the seal lip seriously impairs efficiency.

8. After hub has been installed on the axle tube replace inner tube nut and tighten until drag is felt when turning the hub. (Be sure brake shoes are not causing drag). Back off the nut slightly until the hub turns free and install nut lock, outer tube nut and tighten. Clinch nut lock to retain nuts in this position.

9. Coat the axle shaft flange to hub mating surface with #2 Permatex.

Insert axle shaft in tube and rotate slowly until splines on shaft are in registry with the differential side gears. Push shaft in and install the retaining screws and tighten to 52-57 ft. pounds torque.

10. Install wheels on hub and inflate tires to proper pressure. Tilt the upright back and remove blocks from under upright rails.

BRAKE BLEEDING PROCEDURE

Proper operation of the hydraulic brake system requires a solid column of fluid without air bubbles at all points in the pressure system. Under certain conditions it becomes necessary to bleed fluid from the system in order to expel air bubbles which have become mixed with the fluid. The necessity of bleeding is indicated by a soft or spongy pedal, or at any time a brake line is removed (or broken) the system must be bled.

Step 1. If Bleeder Screws are not accessible with wheels on machine, tilt upright back. Plate solid heavy blocks under each upright rail. Tilt upright forward to allow the drive wheels to clear the floor. Remove drive wheels.

N O T E

MACHINES EQUIPPED WITH PNEUMATIC TIRES, DEFLATE TIRES BEFORE REMOVING DRIVE WHEELS FROM MACHINE.

Step 2. Check the brake pedal free travel. Clean dirt from around the filler cap of the master cylinder reservoir. Brake fluid should be within 1/4" of the top. With filler cap off the master cylinder, depress and release brake pedal. A small displacement of fluid should be noticed in the cylinder reservoir. If this happens, the brake pedal (upon being released) is returning the master cylinder piston to its normal position to open a master cylinder port. This port must be open. If fluid does not return to the reservoir (when releasing brake pedal), this indicates improper pedal free travel and a pedal adjustment is required.

Step 3. To properly bleed the system it is recommended that a pressure bleeder filled with about two quarts of S.A.E. 70R3 heavy duty brake fluid be connected to the master cylinder reservoir. Pressure bleeder should then be pressurized to approximately 30 P.S.I.

Step 4. Install a bleeder hose on the right front wheel cylinder bleeder screw and submerge the unattached end of the hose in a clean transparent jar containing several inches of brake fluid. **NOTE: DURING BLEEDING OF THE WHEEL CYLINDERS THE JAR SHOULD BE ELEVATED TO A POSITION HIGHER THAN THE BLEEDER SCREWS MAKING SURE THAT THE END OF THE HOSE REMAINS SUBMERGED IN THE FLUID AT ALL TIMES.** Loosen bleeder screw (Plate 7360) enough to allow fluid and air to escape. Tighten bleeder screw at this point when escaping fluid is free of air bubbles.

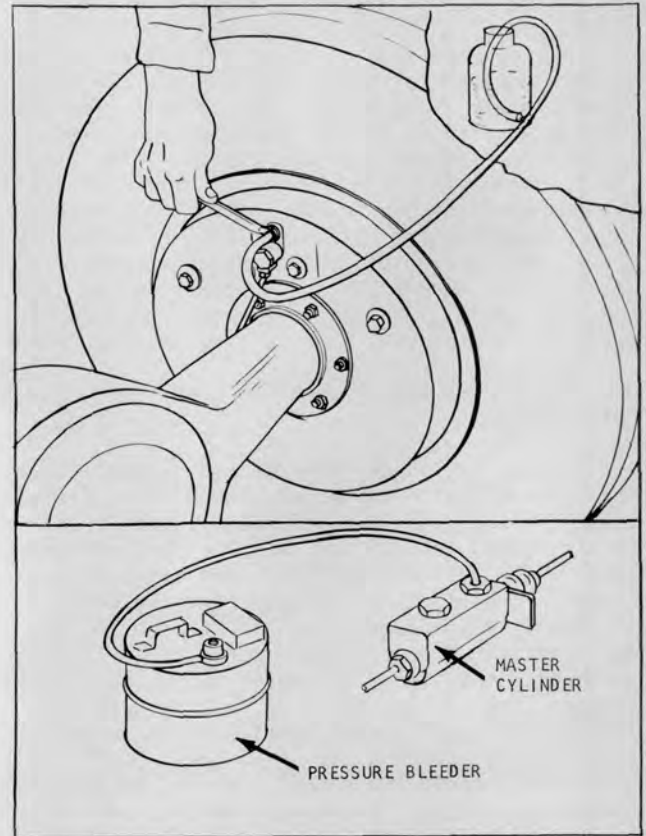

Plate 7360. Bleeding Brakes

Step 5. Install bleeder hose on the remaining bleeder screw and proceed as in step four. After all bleeding has been completed close the pressure bleeder shut-off cock and loosen hose connection at master cylinder to allow pressure to escape. Replace master cylinder cap.

Step 6. Replace drive wheels if they were removed. (Inflate tires if they are of the pneumatic type).

Step 7. Tilt upright back and remove blocking from under each upright rail.

If a pressure bleeder is unavailable the system may be bled manually by following step four. It must be remembered that the brake pedal should be depressed slowly and held to the floorboard until the bleeder screws are securely tightened. This prevents the possibility of air being drawn into the system during the bleeding operation. Check master cylinder reservoir level periodically during manual bleeding and fill to within 1/4 inch of the top as required.

HYDRATORK INCHING MECHANISM BLEEDING PROCEDURE

Proper operation of the inching mechanism requires a solid column of fluid without air bubbles at all points in the pressure system. Under certain conditions it becomes necessary to bleed fluid from the system in order to expel air bubbles which have become mixed with the fluid. The necessity of bleeding is indicated by poor regulation of power disengagement from the drive wheels during depression of the inching pedal, or at any time a line is removed (or broken) the system must be bled.

Step 1. Apply parking brake and shut off engine.

Step 2. Check the inching pedal free travel. Clean dirt from around the filler cap of the inching cylinder reservoir. Brake fluid should be within 1/4" of the top. With filler cap off the inching cylinder, depress and release inching pedal. A small displacement of fluid should be noticed in the cylinder reservoir. If this happens, the inching pedal (upon being released) is returning the inching cylinder piston to its normal position to open an inching cylinder port. This port must be open. If fluid does not return to the reservoir (when releasing inching pedal), this indicates improper pedal free travel and a pedal adjustment is required.

Step 3. To properly bleed the system it is recommended that a pressure bleeder containing about one quart of S.A.E 70R3 heavy duty brake fluid be connected to the reservoir of the inching cylinder. Pressure bleeder should then be pressurized to approximately 20 P.S.I.

Step 4. Loosen the tube nut at the transmission control cover (see Plate 7711) enough to allow fluid and air to escape. Tighten tube nut when escaping fluid is free of air bubbles.

Step 5. After bleeding is completed, shut off the pressure bleeder shut-off cock and loosen hose connection at inching cylinder to allow pressure to escape. Make Sure that the vent on the inching cylinder cap is open before replacing it on the cylinder.

If a pressure bleeder is unavailable the system may be bled manually by following Step 4. It must be remembered that the inching pedal should be depressed slowly and held in the depressed position until the tube nut is securely tightened. This prevents the possibility of air being drawn into the system during the bleeding operation. It may be necessary to repeat this procedure several times to expel all air from the system. Check inching cylinder reservoir level periodically during manual bleeding and fill to within 1/4 inch of the top as required.

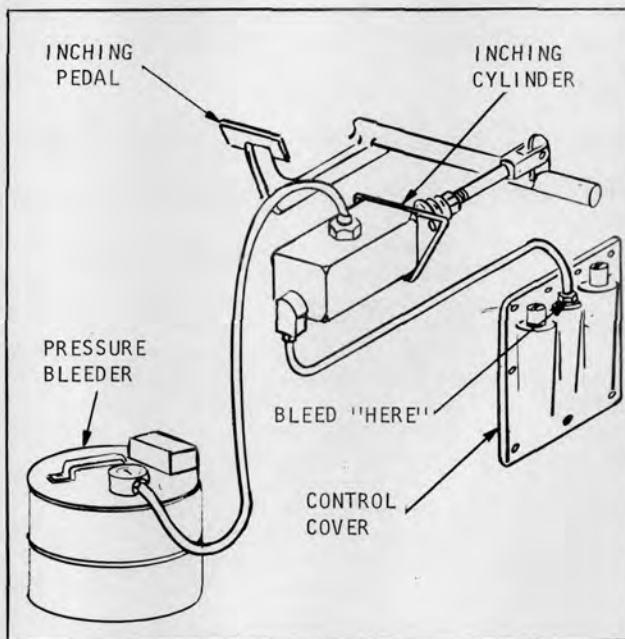

Plate 7711. Bleeding Inching Control

MINOR BRAKE ADJUSTMENT (LINING CLEARANCE)

When drums are hot, allow to cool, then proceed as follows:

a. Adjust brake pedal free travel to allow travel of 3/16 to 1/2 inch.

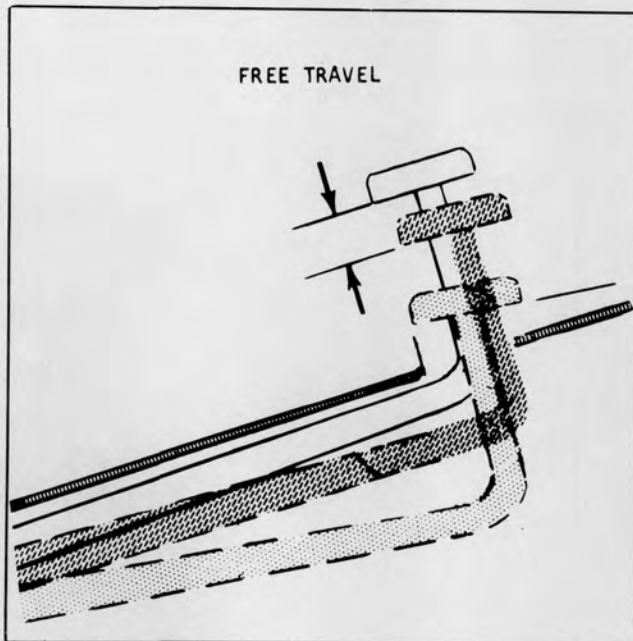

Plate 7048. Brake Pedal Free Travel

b. Raise vehicle until drive wheels clear the ground.

WARNING

PRIOR TO ANY LINING CLEARANCE ADJUSTMENT, PLACE BLOCKING UNDER VEHICLE FRAME SO IT CANNOT BECOME LOWERED BY ACCIDENT. BLOCKING MUST BE OF ADEQUATE STRENGTH TO SUPPORT THE WEIGHT OF THE VEHICLE.

c. Fully release parking brake.

d. Remove rubber seal from backing plate. See Plate 6278.

e. Insert screwdriver in backing plate slot, engaging the star wheel adjuster.

f. Using slot edge as a fulcrum, move screwdriver handle toward axle to rotate star wheel.

g. Rotate star wheel adjuster until brake linings drag on drum.

h. Back off star wheel adjustment fourteen notches. This setting should release drag and provide sufficient shoe working clearance. Replace rubber seal on backing plate.

i. Repeat the above adjustment procedure on the opposite brake assembly.

j. Remove blocking, lower vehicle to ground. Test brakes.

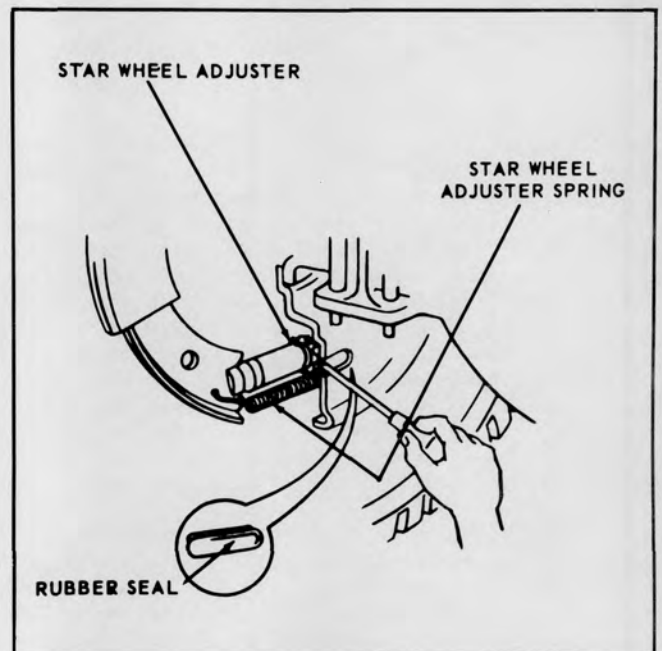

Plate 6278. Typical Minor Brake Adjustment

INDUSTRIAL TRUCK DIVISION

INDUSTRIAL TRUCK DIVISION

1. The first step in the process of...

2. The second step is to...

3. The third step is to...

4. The fourth step is to...

5. The fifth step is to...

STAR WHEEL ADJUSTER

STAR WHEEL ADJUSTER

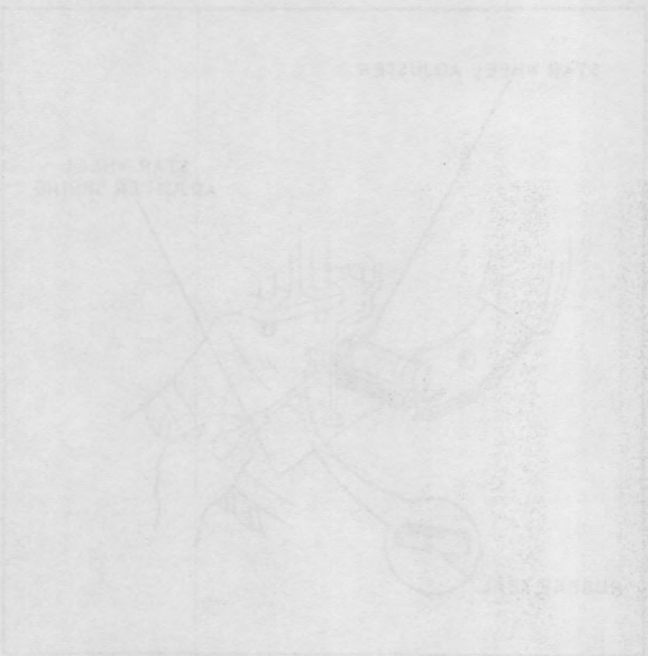

HAND BRAKE ADJUSTMENT

The brake is located on the drive shaft just behind the front drive axle differential, see Plate 6470. The brake has two adjustments. A minor adjustment may be made at the Actuating Lever located in the driver's compartment. If necessary, a major adjustment may be made at the brake assembly. Brake adjustments are made as follows:

1. Minor Adjustment: Rotate knob on top of the hand brake lever clockwise to increase tension, or counterclockwise to loosen tension. Adjustment should be made with hand lever in fully released position, then test adjustment by applying (pivoting) lever to set brake. See Plate 6505.

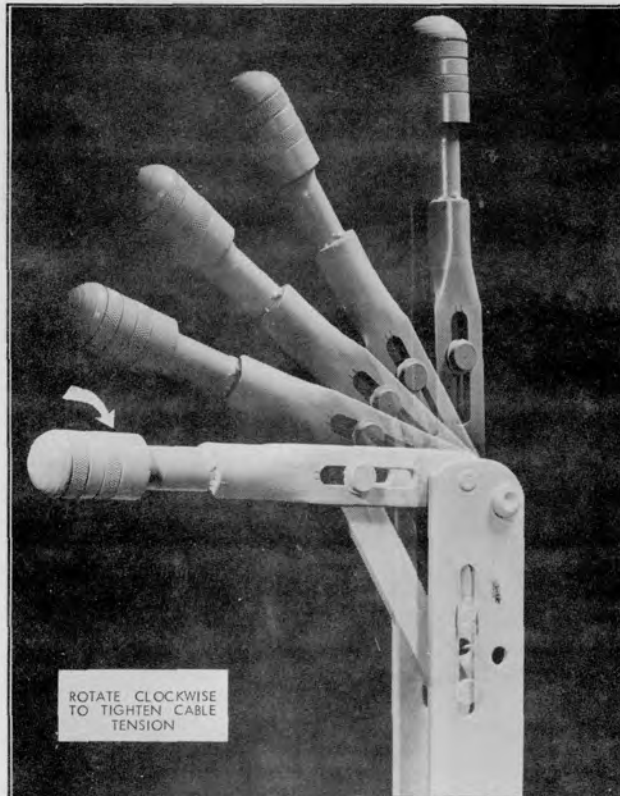

Plate 6505. Hand Brake (Actuating) Lever

2. Major Adjustment: If a major adjustment is necessary to provide proper brake lever release travel and also to provide proper brake tension, proceed as follows:

a. Set hand brake lever in fully released position and turn knob adjustment counterclockwise as far as possible, see Plate 6505.

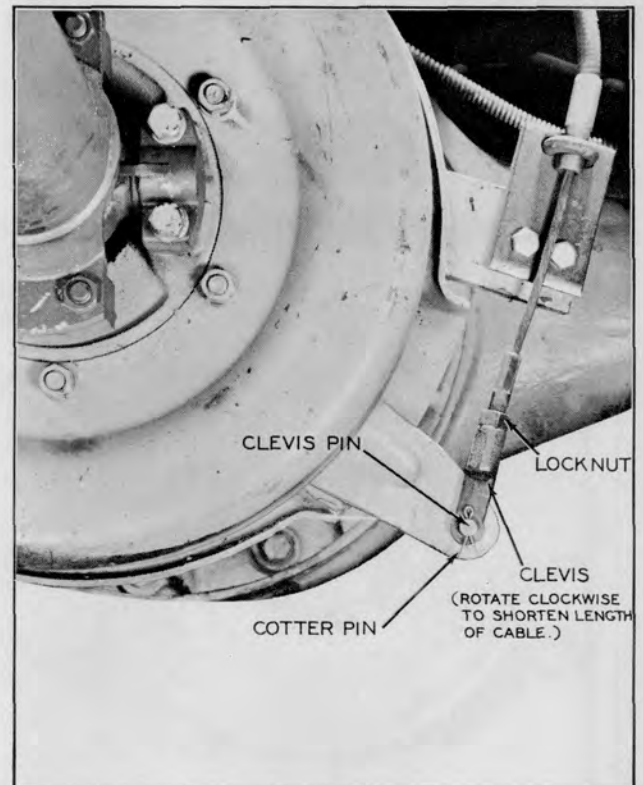

Plate 6470. Brake Assembly

b. The major adjustment is made at the brake assembly, see Plate 6470. Remove cotter pin and clevis pin releasing clevis from actuating arm of the brake assembly. Loosen clevis lock nut and rotate clevis in a clockwise direction to shorten length of cable. After satisfactory adjustment is made, install clevis and secure with clevis pin and cotter pin. Tighten lock nut.

c. Test brake adjustment at hand lever. If necessary, make minor adjustment at hand lever knob as required.

COOLING SYSTEM

Radiator Pressure Caps:

WARNING

USE EXTREME CARE IN REMOVING THE RADIATOR PRESSURE CAP. IN PRESSURE SYSTEMS, THE SUDDEN RELEASE OF PRESSURE CAN CAUSE A STEAM FLASH AND THE FLASH, OR THE LOOSENED CAP CAN CAUSE SERIOUS PERSONAL INJURY. LOOSEN CAP SLOWLY AND ALLOW STEAM TO ESCAPE.

1. Inspect pressure cap gasket and radiator filler neck to be sure they are providing a proper seal. If the rubber face of the valve is defective, a new cap should be installed.



Plate 6458 Radiator Pressure Cap

2. Inspect pressure cap for freedom of operation.

Pressure caps employ a spring loaded, rubber-faced valve which presses against a seat in the radiator top tank. Pressure caps employ either a vacuum valve held against its seat under spring pressure, or a weighted vacuum valve which hangs open until forced closed by a surge of vapor or coolant. Check to be sure components are free to operate.

NOTE

IF A NEW CAP IS REQUIRED, ALWAYS INSTALL A CAP OF THE SAME TYPE AND PRESSURE RATING.

3. Inspect for dented or clogged overflow pipe. To remove clogged material, run a flexible wire through pipe until obstruction is removed.

When a pressure cap opens the sudden surge of vapor or liquid must pass thru the overflow pipe. If the pipe is dented or clogged, the pressure developed by the obstruction may cause damage to radiator or hoses.

Inspect and Clean Cooling System:

Check hose connections for coolant leaks as well as air leakage. Air leakage around hose connections allows oxygen into the system which is a major factor in corrosion.

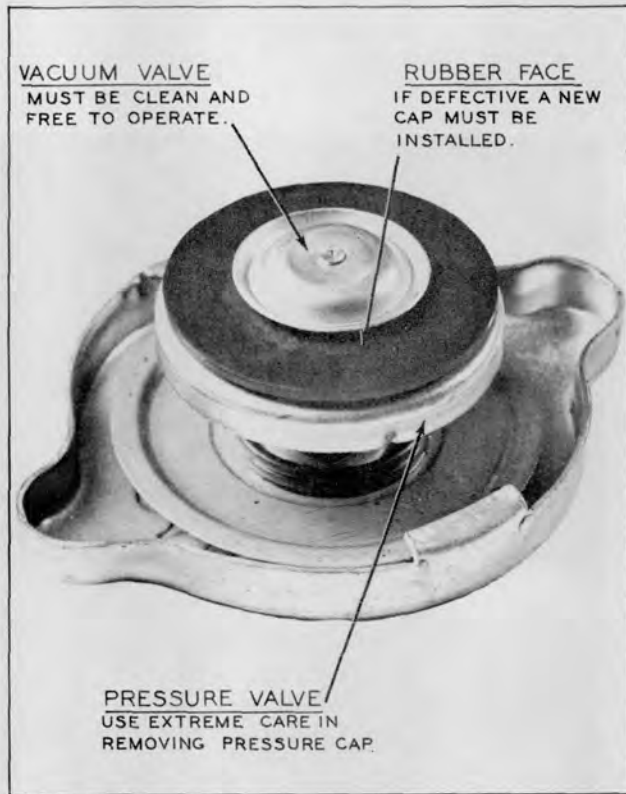

plate 6459 Pressure Cap Gasket, Valve and Valve Gasket

NOTE

EXHAUST GAS LEAKAGE BETWEEN CYLINDER HEAD AND GASKET ALSO RESULTS IN CORROSION. IF EXHAUST GAS DISCHARGES INTO COOLANT, THE COOLANT AND THE GAS COMBINE TO FORM A VARIETY OF ACIDS. IT IS THEREFORE IMPORTANT THAT CYLINDER HEAD STUD NUTS BE DRAWN DOWN TO SPECIFICATIONS AS INSTRUCTED IN "ENGINE TUNE-UP".

LUBRICATION AND PREVENTIVE MAINTENANCE

Using a washing soda solution, flush cooling system in the following manner:

1. Drain system.
2. Replace half of volume with fresh water. Refer to Specifications for capacity.
3. Boil other half of volume and add washing soda until no more will dissolve.
4. Add hot soda solution to cooling system (fill up).
5. Operate engine normally for 24 hours.
6. Drain, flush, refill with clean water to which a soluble oil has been added in a proportion of 1 ounce per gallon of water.

Maintaining the cooling system efficiency is important, as engine temperatures must be brought up to and maintained within satisfactory range for efficient

operation; however, must be kept from overheating, in order to prevent damage to valves, pistons and bearings. Continued overheating may cause internal damage, while continuously low operating temperature wastes fuel, increases engine wear and causes oil sludge and corrosion of engine parts.

Overcooling may be caused by operating conditions such as excessive idling, low speeds and light loads during cold weather. Overheating may be caused by faulty thermostat, clogged radiator or an improperly adjusted fan belt.

CAUTION

NEVER POUR COLD WATER OR COLD ANTI-FREEZE INTO THE RADIATOR OF AN OVERHEATED ENGINE. ALLOW THE ENGINE TO COOL AND AVOID THE DANGER OF CRACKING THE CYLINDER HEAD OR BLOCK. KEEP ENGINE RUNNING WHILE ADDING WATER.

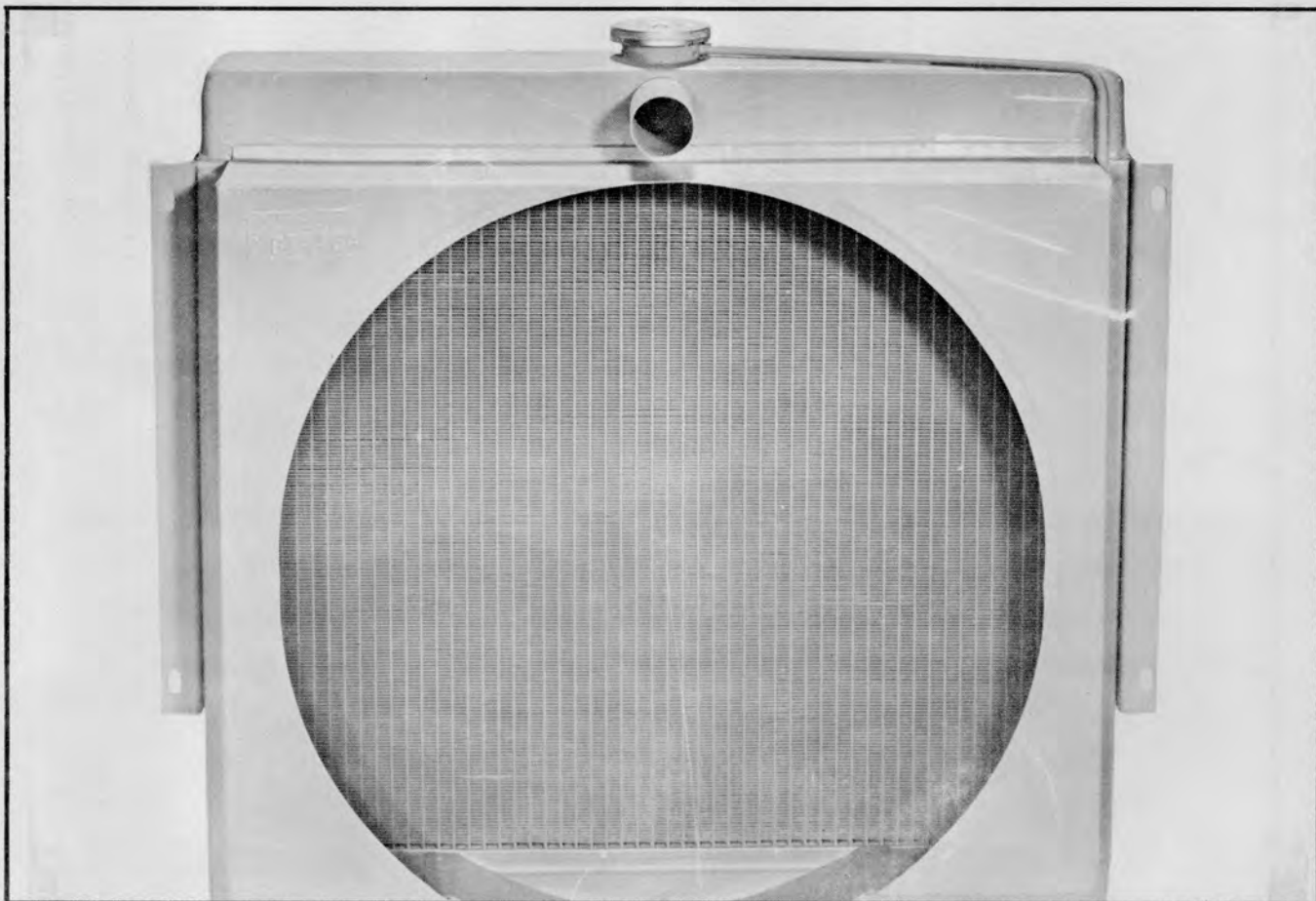

plate 6461 Typical Radiator

INDUSTRIAL TRUCK DIVISION

OPERATION AND MAINTENANCE

The radiator is a device for cooling the engine. It consists of a series of tubes through which water flows. The water is heated by the engine and then cooled by the air passing over the tubes. The cooled water then returns to the engine to be heated again.

The radiator is located at the front of the engine compartment. It is connected to the engine by two hoses. One hose carries the water from the engine to the radiator, and the other carries the water from the radiator back to the engine.

When the engine is running, the water in the radiator is heated and expands. This causes the water to rise in the upper part of the radiator. The air passing over the radiator then cools the water, causing it to contract and sink to the bottom. This creates a circulation of water that keeps the engine cool.

The radiator is a critical part of the engine's cooling system. If it becomes clogged or damaged, the engine will overheat and may be damaged. It is important to check the radiator regularly and to clean it if necessary.

The radiator should be filled with a mixture of water and antifreeze. The antifreeze prevents the water from freezing in cold weather and from boiling in hot weather. The correct mixture is usually 50% antifreeze and 50% water.

The radiator cap is an important part of the cooling system. It maintains the pressure in the system, which raises the boiling point of the water. This prevents the water from boiling and causing damage to the engine. The cap should be checked regularly and replaced if necessary.

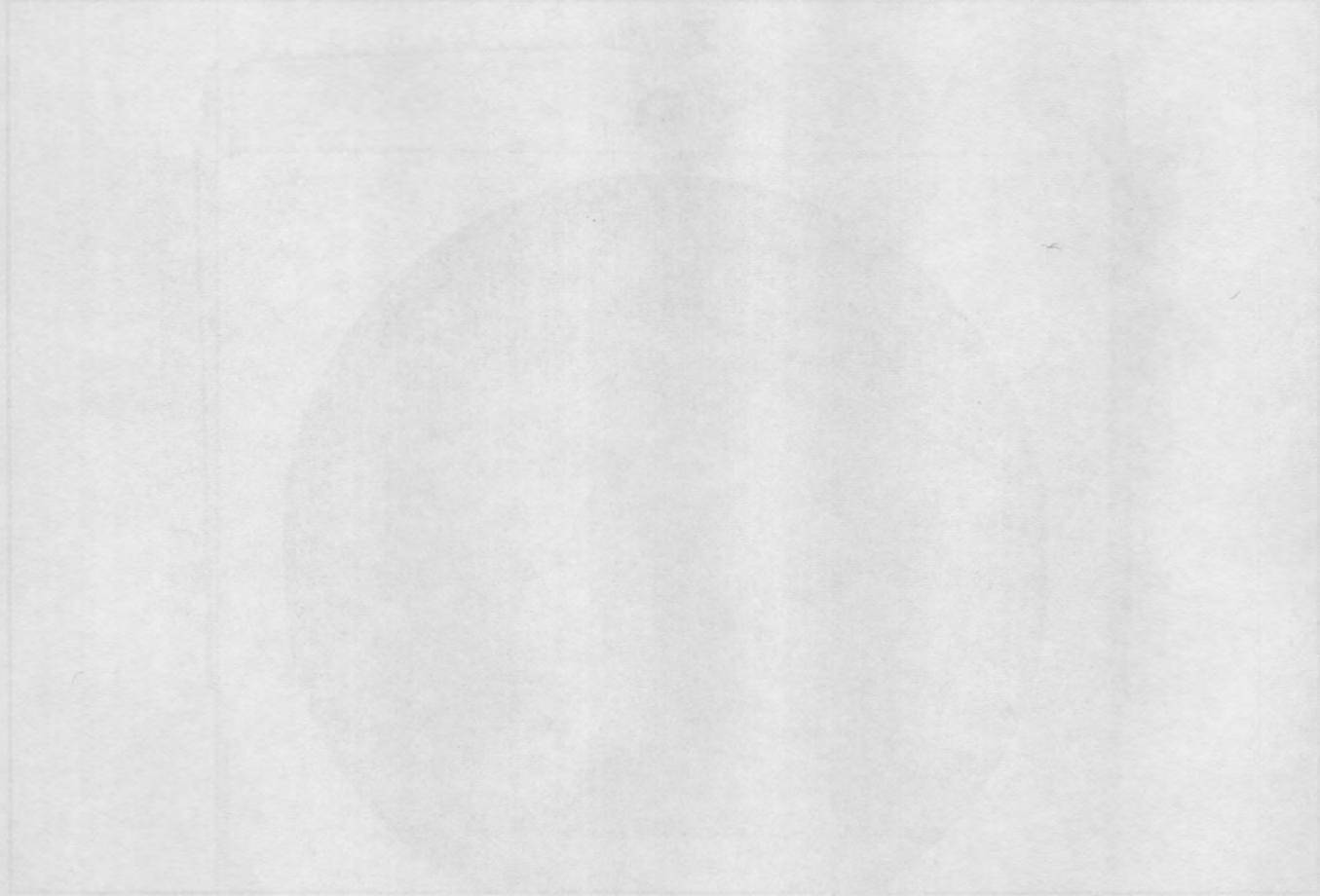

INDUSTRIAL TRUCK DIVISION

STATIONERY AND REPRINTS DEPARTMENT

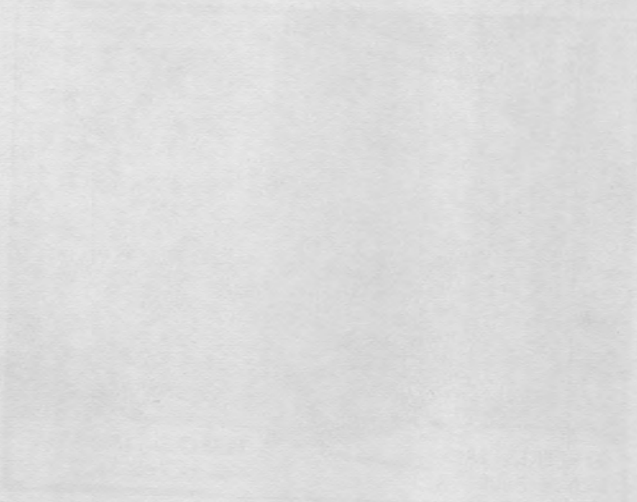

STATIONERY
The Industrial Truck Division of the
General Motors Corporation is pleased
to announce the availability of a new
line of stationery and reprints.
This new line includes a variety of
forms, letterheads, and reprints
designed to meet the needs of the
industrial truck industry. The new
line is available in a variety of
formats and is designed to be
easy to use and understand.
For more information, please contact
the Stationery and Reprints Department
of the Industrial Truck Division.
We will be glad to assist you in
selecting the stationery and reprints
that are best suited to your needs.

INDUSTRIAL TRUCK DIVISION

DIFFERENTIAL

Drain differential by removing the drain plug from the differential bowl. Drain differential at operating temperatures.

After the differential is completely drained replace the drain plug and refill the differential with E.P.G.L. S.A.E. #90 Clark specification MS 8. Do not overfill, as the excess quantity will serve no useful purpose. If the Oil Level is too high, it will cause excessive oil churning and attendant high oil temperature and possible leakage.

DIFFERENTIAL BREATHER

Inspect the differential breather for cleanliness. Remove and clean in a Stoddard type cleaning solvent if necessary. Dry breather with compressed air before replacing it on the differential.

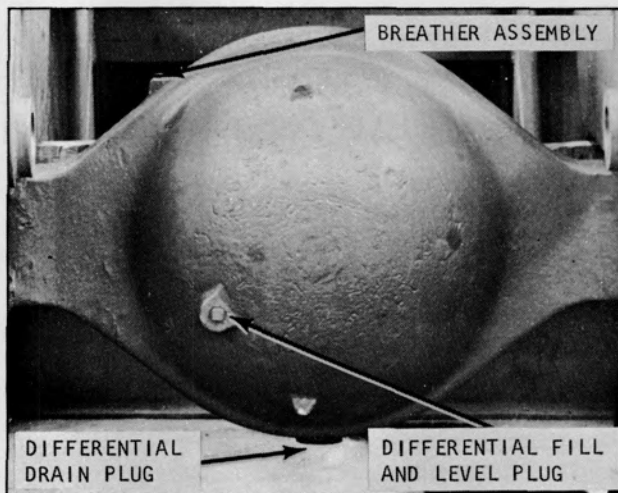

Plate 7336. Differential Drain and Fill Plugs

HYDRAULIC SUMP TANK

Drain and refill with Hydraulic Fluid. Use fluid meeting Clark Specification MS-68.

C A U T I O N

THE HYDRAULIC SYSTEM MUST BE KEPT CLEAN. IT MAY BE NECESSARY TO DRAIN, CLEAN AND REFILL THE SUMP TANK MORE OFTEN UNDER ADVERSE CONDITIONS. THIS IS BEST DETERMINED BY CHECKING CONDITION OF THE HYDRAULIC FLUID FOR EVIDENCE OF DIRT, SLUDGE OR ANY FOREIGN MATTER AT PERIODIC INTERVALS.

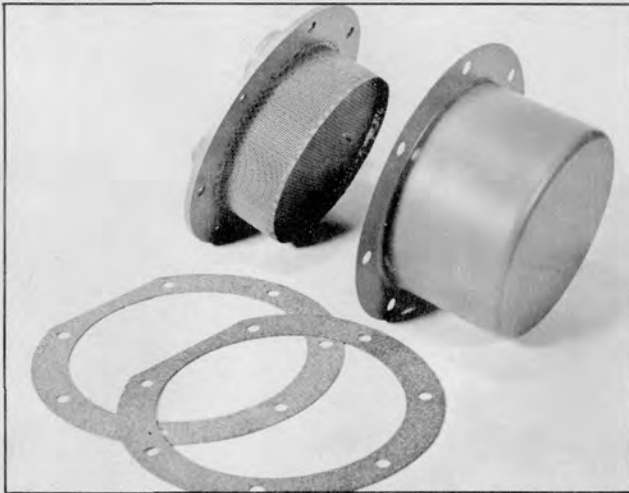

Plate 7657. Typical Hydraulic Fluid Strainer Components

1. Lower upright. Shut engine off.
2. Place a container of adequate capacity underneath the sump tank (approximately 30 gallons) which is located in front of the steer wheel on the right side of the machine.
3. Remove sump tank drain plug, located at bottom of tank, and allow the fluid to completely drain. Replace drain plug.

C A U T I O N

DO NOT OPERATE ENGINE WHILE SUMP TANK IS EMPTY AS DAMAGE TO THE HYDRAULIC PUMP WILL RESULT.

4. Remove and Clean Sump Tank Strainer: The sump tank strainer is located on the inward side of the box type frame that also serves as the sump tank.

- a. Disconnect hoses leading to sump strainer and remove strainer retaining bolts.
- b. Pull strainer assembly out of sump tank.
- c. Remove any remaining gasket material from mounting flange.
- d. Clean sump strainer in a Stoddard type cleaning solvent. After all foreign material has been cleaned from strainer it should be dried with filtered compressed air.
- e. Install strainer in sump tank using new gaskets. Secure strainer assembly with the retaining bolts. Tighten all bolts evenly.
- f. Install hoses to strainer and tighten hose connections.

C A U T I O N

BE SURE ALL CONNECTION ARE AIR TIGHT. AIR ENTERING ON THE SUCTION SIDE OF HYDRAULIC PUMP WILL RESULT IN DAMAGE TO THE PUMP.

- g. Place or solder a fine-mesh wire screen into the large end of a funnel spout. Thoroughly clean funnel before putting it into use. Remove sump breather and fill the sump tank to within 2 inches from the top of the tank. Remove the funnel from the tank and install the breather cap.

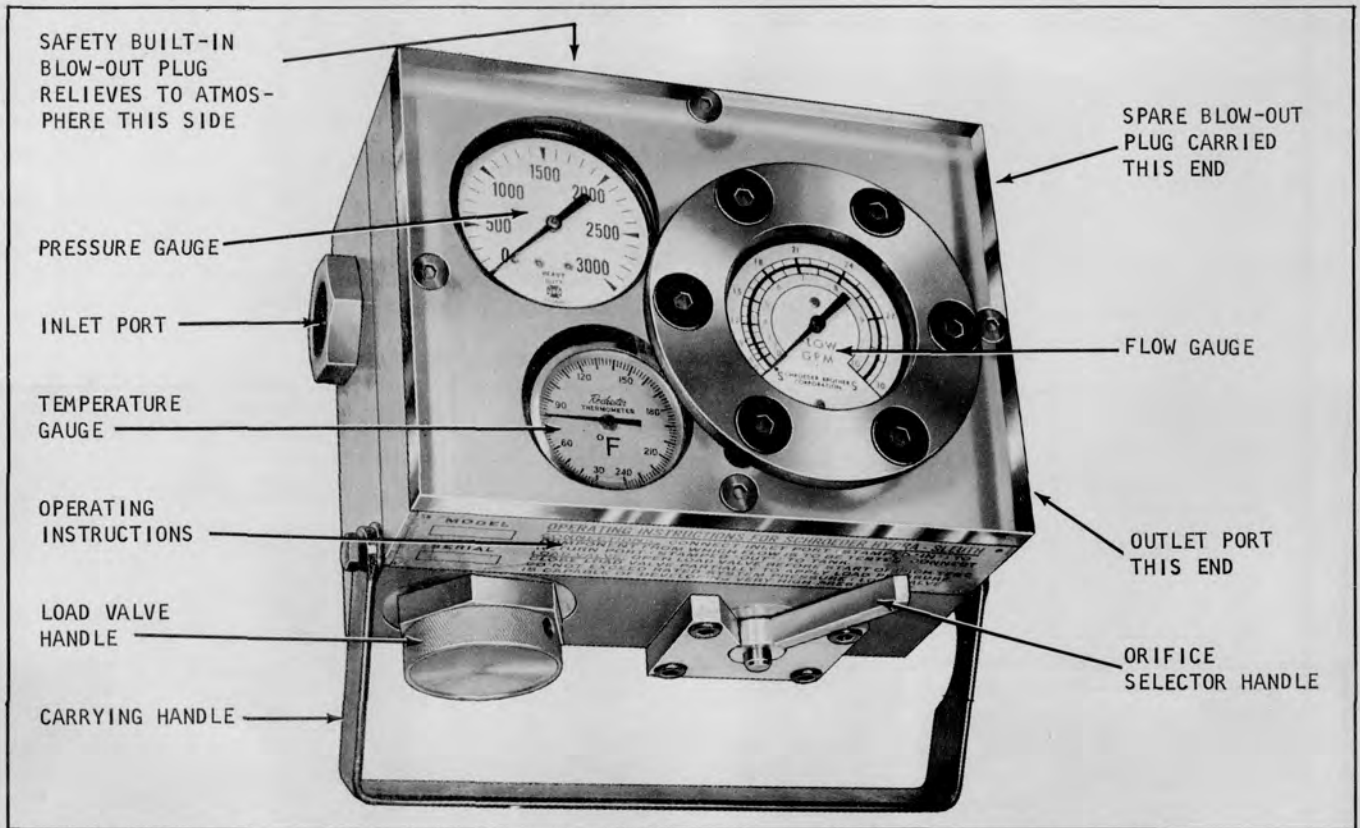

Plate 6747. Schroeder Hydraulic Circuit Tester CLARK PART NUMBER 1800060

PRESSURE GAUGE

Reads directly in pounds per square inch (PSI).

TEMPERATURE GAUGE

Reads directly in degrees Fahrenheit and indicates the temperature of the oil passing through the instrument.

FLOW GAUGE

Reads two scales in gallons per minute.

- 0 - 30 gallons
- 9 - 30 gallons

Read the scale that corresponds with the orifice selector position.

Turn orifice selector to the left (counter-clockwise) to read 10 gallon scale.

Turn orifice selector to the right (clockwise) to read 30 gallon scale.

You may switch from one scale to the other, while operating machine. Always start on 30 gallon scale.

LOAD VALVE

The load valve is a flow restrictor or shut off valve. Turning the valve to the right throttles flow through the Hydra-Sleuth, thus the operator may load a hydraulic pump or circuit to the desired test pressure, simulating work.

SAFETY PLUG

Located opposite the load valve this plug protects the Hydra-Sleuth and the tested system from pressures in excess of 3200 PSI. When pressure becomes higher the plug will rupture and dump oil to atmosphere.

HYDRAULIC FLUID

Unless marked to the contrary, the unit is for use with petroleum, hydraulic fluids.

HOW TO CONNECT THE PORTABLE TESTER

Using a 1/2" hose or larger, connect tester INLET PORT to the flow to be tested. Connect the tester outlet port to reservoir fill port, or system return line.

HYDRA-SLEUTH ADJUSTMENTS BEFORE OPERATION

A. Depending on flow (GPM) to be checked choose proper orifice. (It is good practice to start always on 30 gallon scale.)

B. Fully open load valve by turning all the way to the left.

HYDRA-SLEUTH ADJUSTMENTS DURING OPERATION

1. Turn load valve to right to develop test pressures.

C A U T I O N

LOAD VALVE IS CAPABLE OF VERY HIGH PRESSURES.

A. Always start test with load valve fully open.

B. Do not exceed design pressure of system under test.

C. Keep load pressures within range of the Hydra-Sleuth pressure gauge.



Plate 6748. Schroeder Hydraulic Circuit Tester

MAIN HYDRAULIC SYSTEM PRESSURE CHECK

The hydraulic relief valve setting may be checked with a hydraulic circuit tester. The pressure should be within the limits listed in specifications.

If a circuit tester is not available the relief valve setting may be checked in the following manner.

1. Connect a pressure gauge that is capable of withstanding 4000 P.S.I. to the pressure test plug opening at the main hydraulic valve. See Plate 7664. If the machine is not equipped with a pressure test plug it will be necessary to install a "tee" in the pressure line to provide a means for connecting a pressure gauge in the circuit.

2. System pressure should be checked with the upright raised to its maximum height and the engine running at top governed R.P.M. Momentarily hold the lift lever in raise position to "load" the hydraulic pump. With the pump under load in this manner, check the pressure gauge reading. Pressure should be within the limits listed in specifications. If adjustment is necessary, remove acorn nut at valve and turn adjuster clockwise to raise pressure, counterclockwise to lower pressure. After correct adjustment is obtained replace acorn nut and tighten securely.

3. Remove pressure gauge and "tee" if used, from the circuit and reinstall test plug and all fittings. Operate hydraulic controls and check to be sure there are no leaks in the hydraulic system.

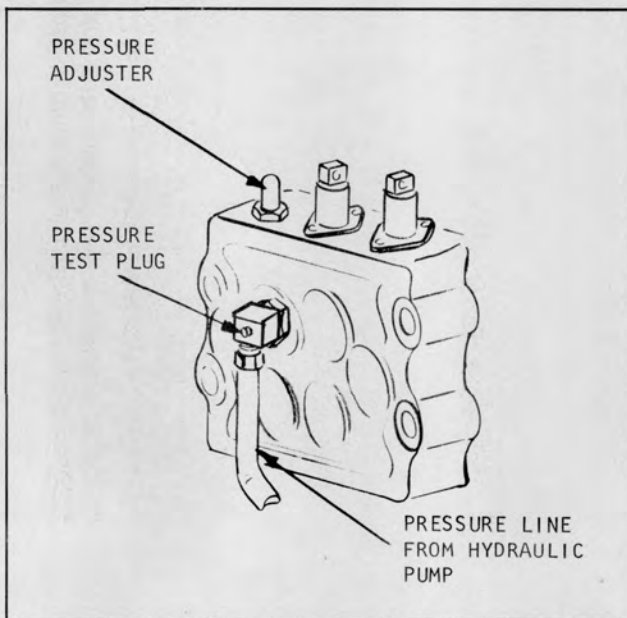
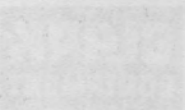

Plate 7664. Main Hydraulic System Pressure Check

INDUSTRIAL TRUCK DIVISION



Product of the Industrial Truck Division

The Industrial Truck Division is a leading manufacturer of industrial trucks, including forklifts, pallet trucks, and other material handling equipment. Our products are designed for efficiency, safety, and reliability in industrial and commercial environments. We offer a wide range of models to meet various needs, from compact indoor trucks to heavy-duty outdoor trucks. Our commitment to quality and customer service is reflected in our extensive product line and comprehensive support services.

Our products are used in a variety of industries, including manufacturing, warehousing, and distribution. They are designed to handle heavy loads and operate in demanding conditions. We provide training and technical support to ensure our customers get the most out of their equipment. Contact us today to learn more about our industrial truck solutions.

The Industrial Truck Division is a leading manufacturer of industrial trucks, including forklifts, pallet trucks, and other material handling equipment. Our products are designed for efficiency, safety, and reliability in industrial and commercial environments. We offer a wide range of models to meet various needs, from compact indoor trucks to heavy-duty outdoor trucks. Our commitment to quality and customer service is reflected in our extensive product line and comprehensive support services.

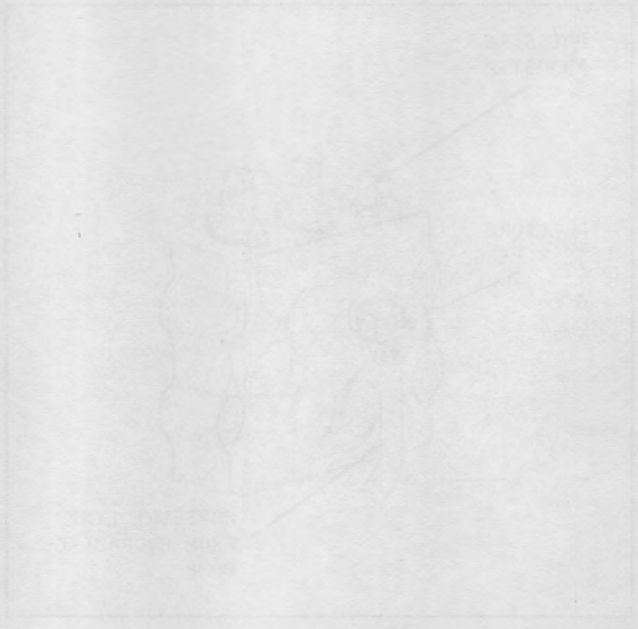

Figure 1: Industrial Truck Chassis Diagram

TRANSMISSION STALL AND PRESSURE CHECKS.
(HYDRATORK MODELS)

Minimum Tools Required.

- 1 - Pressure Guage 0 - 250 P.S.I.
- 1 - Tachometer

Before making transmission checks the machine should be steam cleaned. It is important that the radiator be clean externally and internally so that it is capable of maintaining proper cooling for the engine and transmission.

1. Operate engine 3 to 4 minutes to fully charge the transmission plumbing and the torque converter. With the engine operating at idle and the transmission in "Neutral" check the fluid level on the dipstick. Fill if necessary to the "Cold Full" mark or the "Hot Full" mark -- depending upon the temperature of the transmission. Use Type "A" (Armour Qualified) transmission fluid. Clark part number 879803.

2. Check brake pedal free travel.

The hydraulic inching (brake) pedal must have the proper free travel to allow an accurate check on torque converter and transmission condition. Refer to page 100H 302 for explanatory illustrations on Pedal Free Travel.

3. With a tachometer, check engine for governed speed at full throttle. The unloaded engine R.P.M. should be set at 2600.

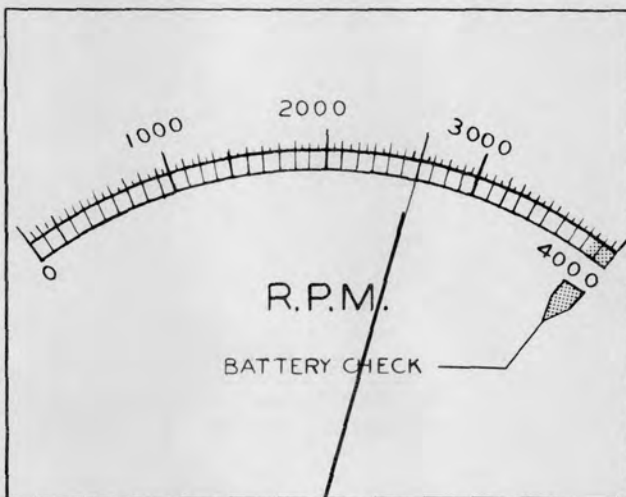

Plate 7661. Engine R.P.M. (no load)

4. Check governed engine speed with partial load -- With engine at full throttle and upright in full backward tilt,

momentarily hold the tilt lever back to load the engine. With the engine loaded in this manner the approximate engine R.P.M. should be 2400.

NOTE

ENGINE MUST BE PROPERLY TUNED BEFORE MAKING TRANSMISSION STALL CHECKS.

CAUTION

PROLONGED STALLING OF THE CONVERTER CAN CAUSE INTERNAL DAMAGE TO THE CONVERTER. STALL CONVERTER ONLY LONG ENOUGH TO ATTAIN THE PEAK R.P.M. READING. (MAXIMUM 30 SECONDS).

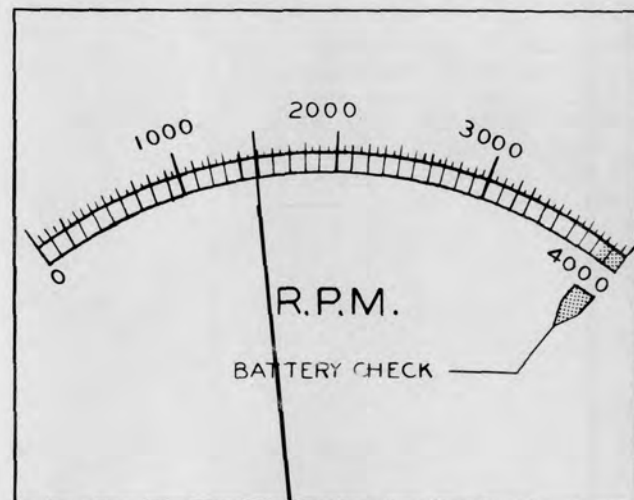

Plate 7662. Normal Engine Stall

5. With a capacity load on the forks, check for normal stall R.P.M. by positioning machine against an immovable object. Place the machine in its highest gear and accelerate engine to full throttle.

Normal Stall for F-244 Engine
1450 to 1550 R.P.M.

WHEN APPLYING BRAKE HYDRAULIC PRESSURE
92# ± 5 TO INCHING VALVE "F" AND "R"
CHECKED INDIVIDUALLY MUST DROP OFF TO
3# ± 2 P.S.I. MAX. WITH INCHING BREAK
OFF POINT OF 55# ± 5

IMMERSE IN UCON-1145 FLUID BEFORE ASSEM.

UNLESS OTHERWISE SPECIFIED

IMMERSE ALL OIL SEALS IN TYPE "A"
TRANSMISSION FLUID BEFORE ASSEMBLY

OIL ALL "O" RINGS BEFORE ASSEMBLY

TIGHTEN ALL CAP SCREWS 20-25 FT. LBS. TORQUE

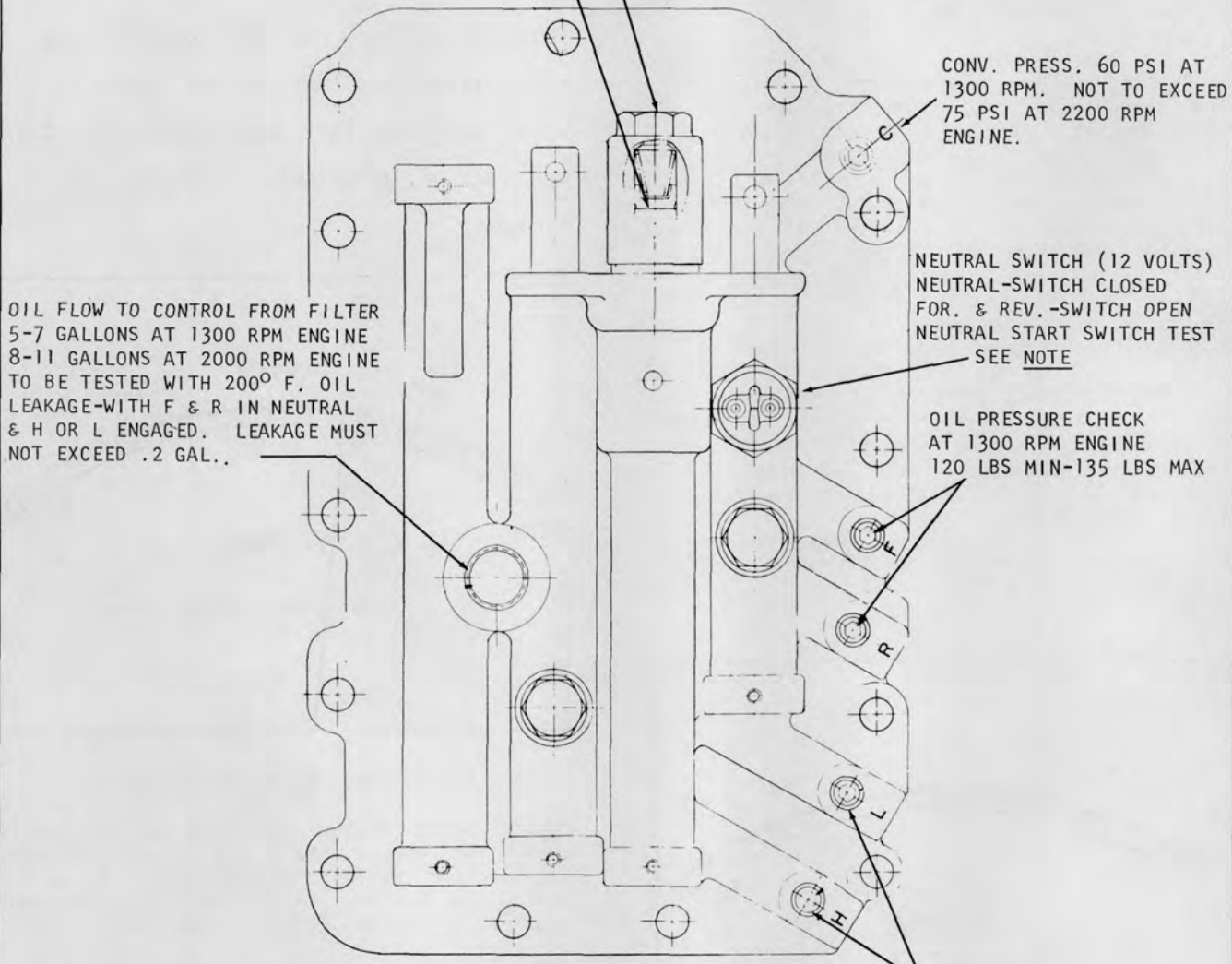

CONV. PRESS. 60 PSI AT
1300 RPM. NOT TO EXCEED
75 PSI AT 2200 RPM
ENGINE.

NEUTRAL SWITCH (12 VOLTS)
NEUTRAL-SWITCH CLOSED
FOR. & REV.-SWITCH OPEN
NEUTRAL START SWITCH TEST
SEE NOTE

OIL PRESSURE CHECK
AT 1300 RPM ENGINE
120 LBS MIN-135 LBS MAX

OIL FLOW TO CONTROL FROM FILTER
5-7 GALLONS AT 1300 RPM ENGINE
8-11 GALLONS AT 2000 RPM ENGINE
TO BE TESTED WITH 200° F. OIL
LEAKAGE-WITH F & R IN NEUTRAL
& H OR L ENGAGED. LEAKAGE MUST
NOT EXCEED .2 GAL.

NOTE

NEUTRAL START SWITCH TEST

- 1-WIRE SWITCH INTO TEST STAND LIGHT CIRCUIT
- 2-WITH ENGINE RUNNING & TRANSMISSION IN LOW
FOR., NUDGE CONTROL FOR. & REV. SPOOL
SLOWLY TOWARD NEUTRAL. IF SWITCH DOES NOT
MAKE CONTACT REPEAT STARTING IN LOW REV.
IF IN EITHER TEST CONTACT IS MADE WHEN NOT
IN DEAD NEUTRAL, SWITCH IS TO BE SHIMED,
TILL TEST SHOWS PROPER FUNCTION.

OIL PRESSURE CHECK

- AT 1300 RPM ENGINE-150 LBS. MIN.
- AT 2200 RPM ENGINE-165 LBS. MAX.

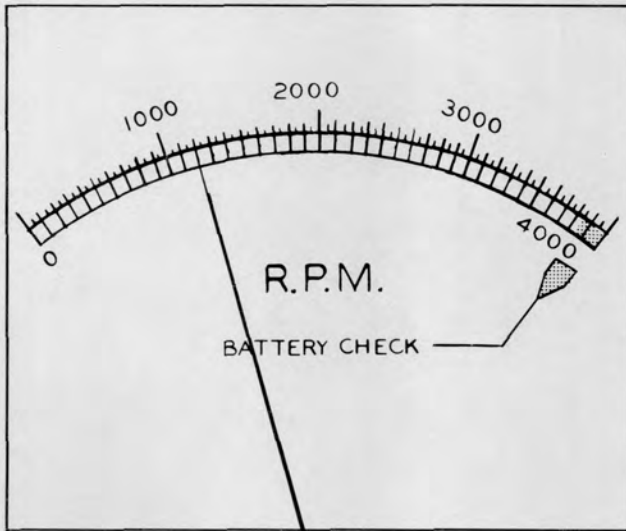

Plate 7327. Interim Stall

If the engine stall R.P.M. is within the following range -- loss of engine power is indicated.

F-209 Engine 1000 to 1300 R.P.M.
F-244 Engine 1150 to 1450 R.P.M.

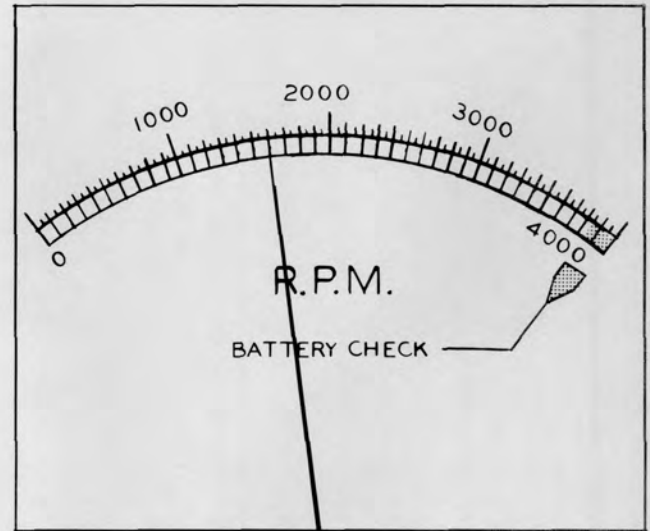

Plate 7328. High Engine Stall

If the engine stall R.P.M. is within the following range -- either slippage of the selector packs or low oil pressure is indicated.

F-209 Engine 1450 R.P.M. and above.
F-244 Engine 1600 R.P.M. and above.

NOTE

ANY STALL READING OTHER THAN NORMAL SHOULD BE REPORTED TO DESIGNATED PERSON IN AUTHORITY.

Transmission Pressure Checks

The transmission pressure checks are made at the testing ports of the control cover. See Plate 7326.

1. Place heavy blocking under the upright rails and tilt upright forward until vertical. This will allow the drive wheels to clear the floor.

2. Install a 250 P.S.I. pressure gauge at one of the testing ports (whichever direction or range of speed being tested.) With shift lever in related position the pressure should be within the range as specified on Plate 7326.

If pressures are not within this range report to designated person in authority.

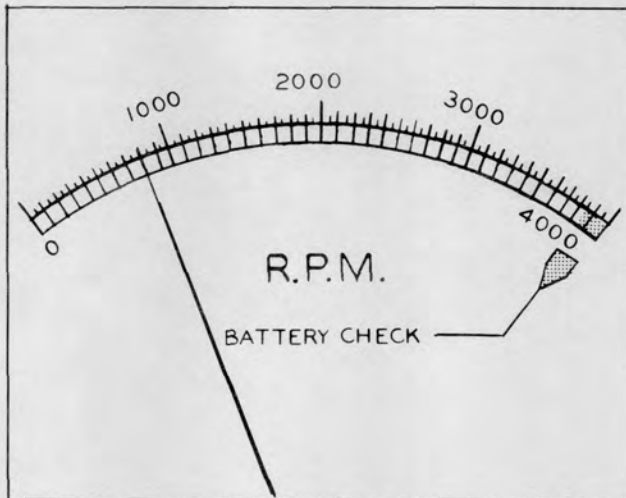

Plate 6686. Low Engine Stall

If the engine stall R.P.M. is within the following range -- converter malfunction is indicated.

F-209 Engine 650 to 900 R.P.M.
F-244 Engine 750 to 1000 R.P.M.

INDUSTRIAL TRUCK DIVISION

FOR THE USE OF THE CUSTOMER

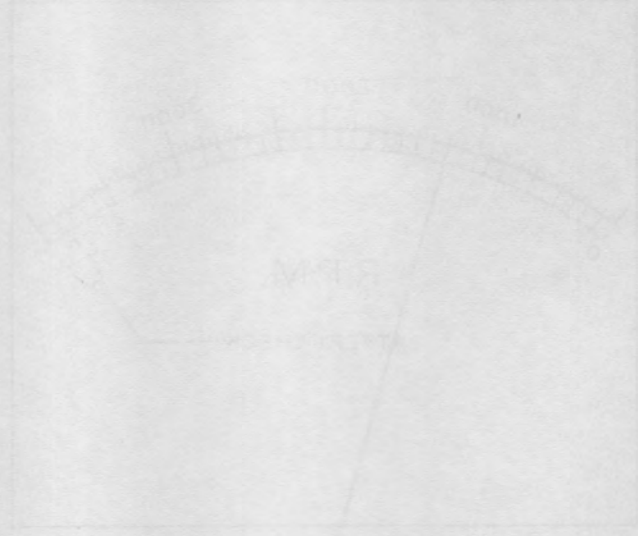
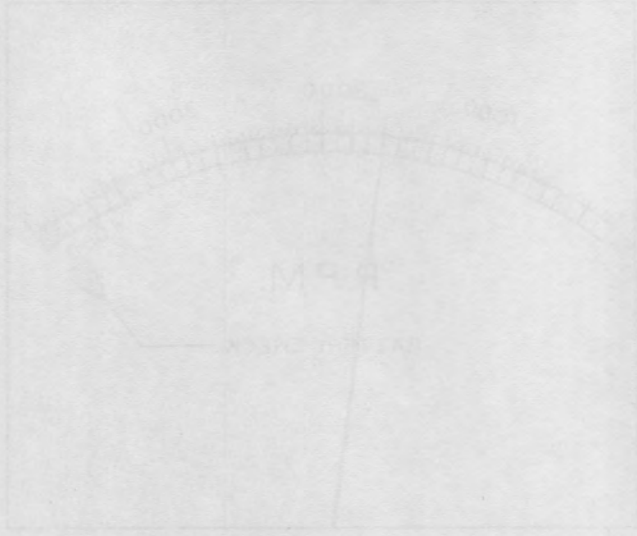

THIS DRAWING IS THE PROPERTY OF THE INDUSTRIAL TRUCK DIVISION AND IS LOANED TO YOU FOR YOUR INFORMATION. IT IS NOT TO BE REPRODUCED OR COPIED IN ANY MANNER WITHOUT THE WRITTEN PERMISSION OF THE INDUSTRIAL TRUCK DIVISION.

THIS DRAWING IS THE PROPERTY OF THE INDUSTRIAL TRUCK DIVISION AND IS LOANED TO YOU FOR YOUR INFORMATION. IT IS NOT TO BE REPRODUCED OR COPIED IN ANY MANNER WITHOUT THE WRITTEN PERMISSION OF THE INDUSTRIAL TRUCK DIVISION.

FOR THE USE OF THE CUSTOMER

THIS DRAWING IS THE PROPERTY OF THE INDUSTRIAL TRUCK DIVISION AND IS LOANED TO YOU FOR YOUR INFORMATION. IT IS NOT TO BE REPRODUCED OR COPIED IN ANY MANNER WITHOUT THE WRITTEN PERMISSION OF THE INDUSTRIAL TRUCK DIVISION.



THIS DRAWING IS THE PROPERTY OF THE INDUSTRIAL TRUCK DIVISION AND IS LOANED TO YOU FOR YOUR INFORMATION. IT IS NOT TO BE REPRODUCED OR COPIED IN ANY MANNER WITHOUT THE WRITTEN PERMISSION OF THE INDUSTRIAL TRUCK DIVISION.

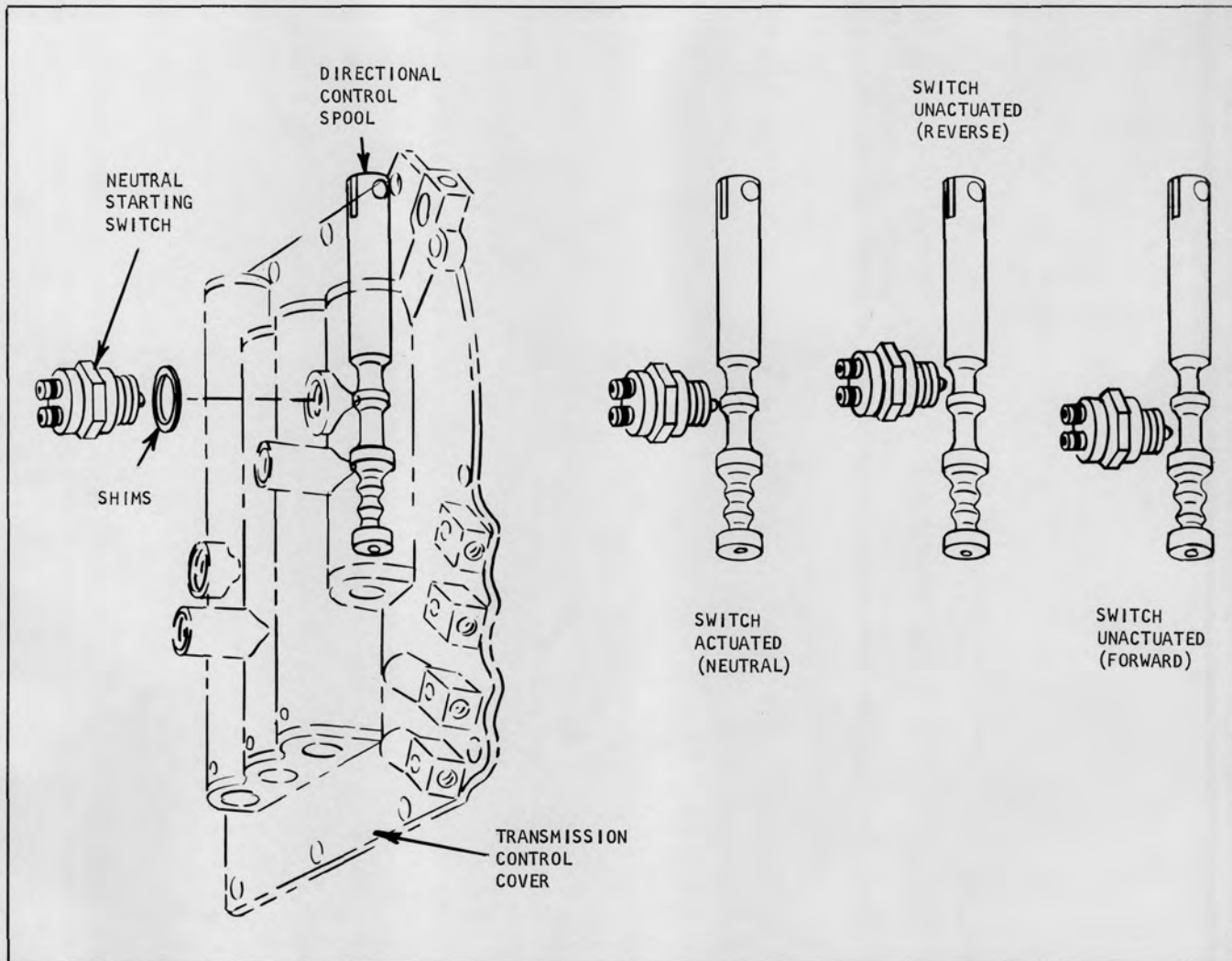

Plate 7300. Neutral Starting Switch

NEUTRAL STARTING SWITCH

The neutral starting switch should be adjusted so that machine will not start except when the transmission control is in the (dead) neutral position.

ADJUSTMENT

1. With driver's seat occupied and transmission in gear hold starting switch in actuated position and gently move shift lever towards neutral position.

2. If engine does not start, repeat operation in opposite direction.

3. If engine starts, coming from either direction on the shift lever prior to reaching neutral, switch should be adjusted by means of shims underneath the switch until engine will not start unless it is in (dead) neutral; that is, vehicle will not move regardless of shift lever position during the starting cycle.

INDUSTRIAL TRUCK DIVISION

REGULATOR AND MOVING MOUNTING

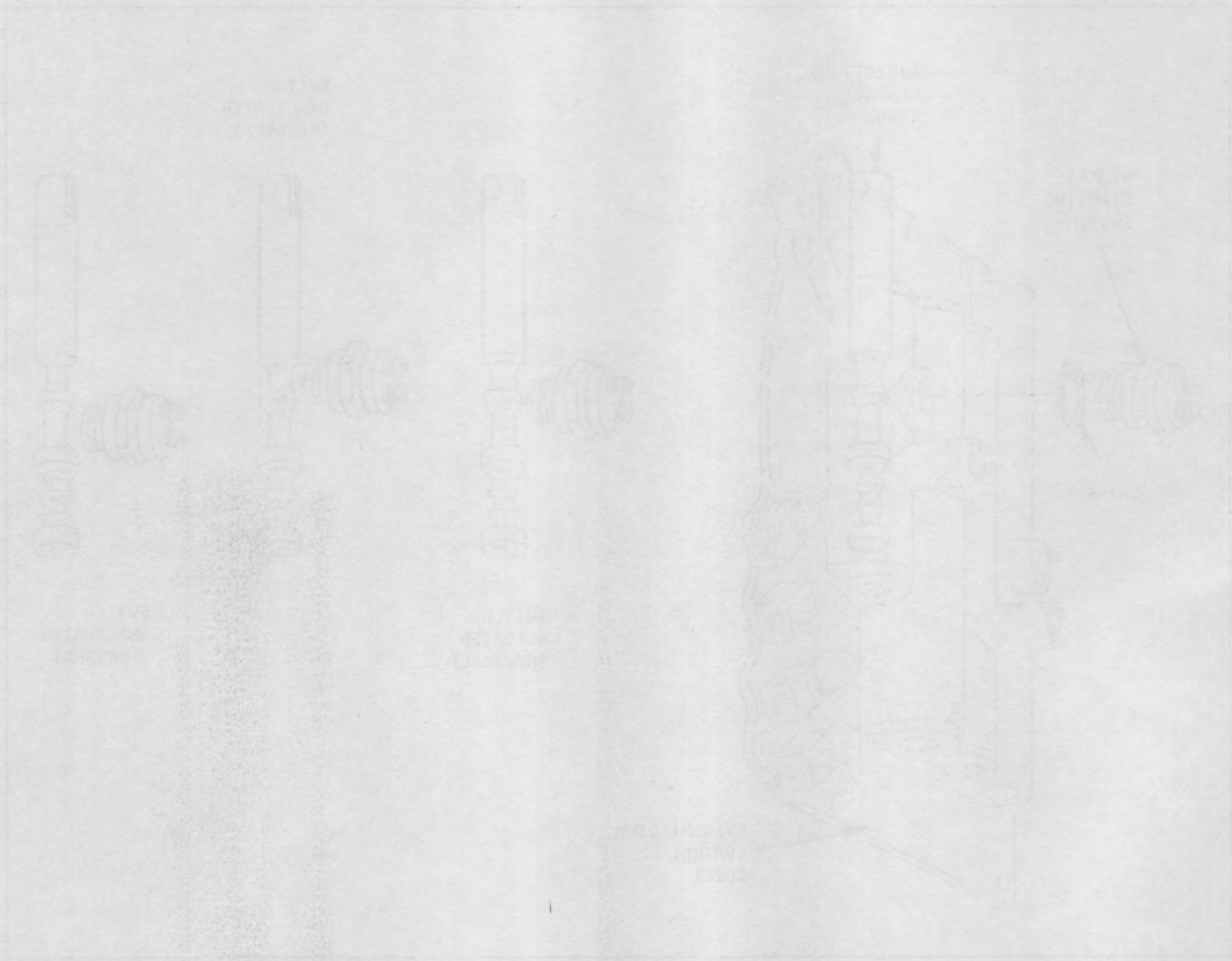

Fig. 1. Regulator and moving mounting.

The regulator and moving mounting are used for the purpose of adjusting the pressure in the hydraulic system. The regulator is a mechanical device which maintains a constant pressure in the system. The moving mounting is a device which allows the pressure to be adjusted. The regulator and moving mounting are connected to the hydraulic system by means of hoses and fittings. The regulator is mounted on the side of the hydraulic tank and the moving mounting is mounted on the top of the tank. The regulator and moving mounting are used to adjust the pressure in the hydraulic system to the required level. The regulator and moving mounting are used to adjust the pressure in the hydraulic system to the required level. The regulator and moving mounting are used to adjust the pressure in the hydraulic system to the required level.

The regulator and moving mounting are used for the purpose of adjusting the pressure in the hydraulic system. The regulator is a mechanical device which maintains a constant pressure in the system. The moving mounting is a device which allows the pressure to be adjusted. The regulator and moving mounting are connected to the hydraulic system by means of hoses and fittings. The regulator is mounted on the side of the hydraulic tank and the moving mounting is mounted on the top of the tank. The regulator and moving mounting are used to adjust the pressure in the hydraulic system to the required level. The regulator and moving mounting are used to adjust the pressure in the hydraulic system to the required level. The regulator and moving mounting are used to adjust the pressure in the hydraulic system to the required level.

**LIFT CARRIAGE AND UPRIGHT
ROLLER ADJUSTMENTS**

To maintain top performance from the upright it may be necessary, from time to time, to adjust the rollers located on the Lift Carriage and Upright Assembly. These adjustments may be accomplished as follows:

Before checking for proper roller clearance, check to be sure the Inner Slide contacts with

both Fabreeka (Stop) Pads at the same time when lowering the Inner Slide.

If adjustment is required, add or remove shims between Fabreeka (Stop) Pads located on the Outer Rail Tie Bar Assembly.

NOTE: MORE SHIMS MAY BE REQUIRED ON ONE SIDE THAN THE OTHER IN ORDER TO ALLOW THE INNER SLIDE TO COME IN CONTACT WITH BOTH FABREEKA (STOP) PADS AT THE SAME TIME WHEN LOWERING THE INNER SLIDE.

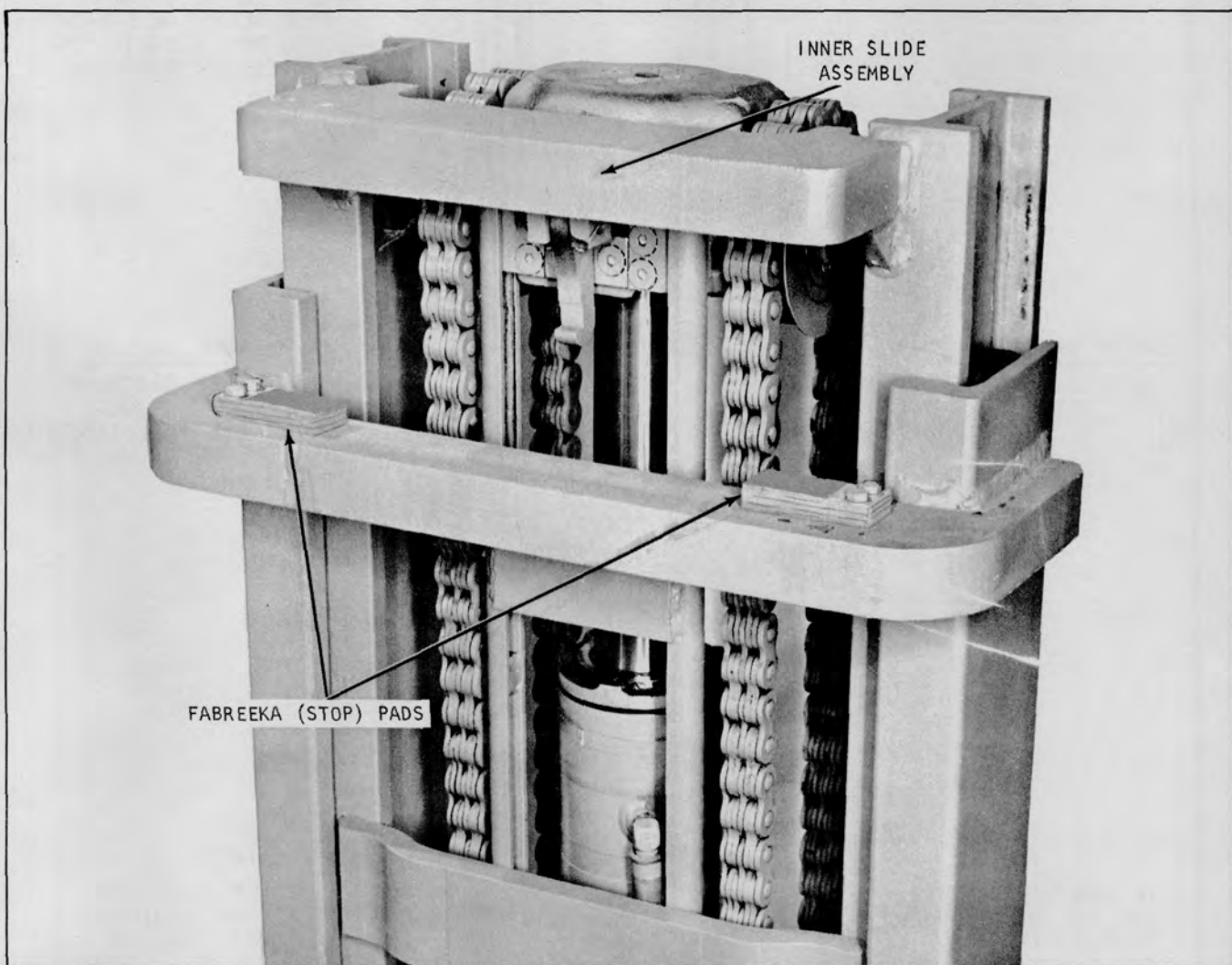
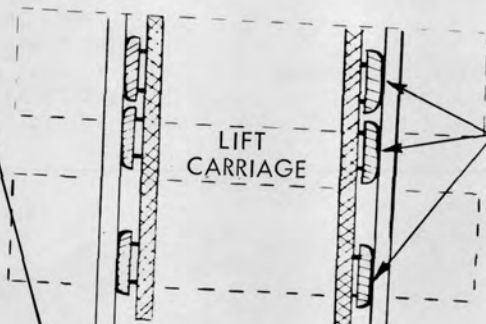

Plate 7660. (Typical Illustration) Inner Slide Must Contact Both Fabreeka (Stop) Pads at the Same Time When Lowering Inner Slide

OUTER RAIL ROLLERS

SHOULD BE CHECKED FOR ROLLER CLEARANCE THE FULL LENGTH OF THE INNER SLIDE RAIL.



LIFT CARRIAGE ROLLERS

SHOULD BE CHECKED FOR ROLLER CLEARANCE THE FULL LENGTH OF THE INNER SLIDE RAIL.

CHECK INNER SLIDE BOTTOM ROLLER

IN THIS 10 TO 20 INCH SECTION OF THE OUTER RAIL.

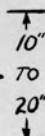

INNER SLIDE ASSEMBLY

NOTE

ROLLER CLEARANCE SHOULD NOT EXCEED 1/32 INCH.

OUTER RAIL ASSEMBLY

OUTER RAIL ROLLERS

SHOULD BE CHECKED FOR ROLLER CLEARANCE THE FULL LENGTH OF THE INNER SLIDE RAIL.

NOTE

IF UPRIGHT RAILS ARE COCKED IN POSITION AS SHOWN, AND IF CLEARANCE IS CHECKED ON THIS SIDE, CLEARANCE IS MEASURED BETWEEN THE UPPER EDGE

OF THE ROLLER RIM AND CORRESPONDING RAIL.

NOTE

IF UPRIGHT RAILS ARE COCKED IN POSITION AS SHOWN, AND IF CLEARANCE IS CHECKED ON THIS SIDE, CLEARANCE IS MEASURED BETWEEN THE LOWER EDGE

OF THE ROLLER RIM AND CORRESPONDING RAIL.

UPRIGHT ROLLER ADJUSTMENTS.

NOTE

THE UPRIGHT OUTER RAIL ASSEMBLY IS MANUFACTURED WITH A SLIGHT TAPER, THE BOTTOM BEING 1/16 INCH WIDER THAN THE TOP. EXTEND THE UPRIGHT TO THE UPPER LIMIT. CHECK TO BE SURE THERE IS NO BIND. LOWER UPRIGHT. IF THERE IS A BIND, THE INNER SLIDE WILL HESITATE OR REMAIN AT THE UPPER LIMIT. AS THE LIFT CYLINDER BEGINS TO RETRACT, THE INNER SLIDE WILL BREAK FREE AND THEN LOWER. THIS INDICATES IMPROPER ADJUSTMENT, OR THIS MAY INDICATE A DAMAGED ROLLER WHICH WILL NOT ROTATE. RAISE AND LOWER CARRIAGE AND CHECK TO BE SURE ALL ROLLERS ROTATE FREELY.

1. Because of the 1/16 inch taper in the Outer Rail Assembly, the rollers may bind when upright is extended if roller adjustment is made with the upright lowered; therefore, the upright must be extended to the upper limit (with no backward or forward tilt) before making any adjustments.

2. Insert pry bar between bottom end of either right or left Inner Slide (Rail), and Outer Rail, refer to Plate 6891.

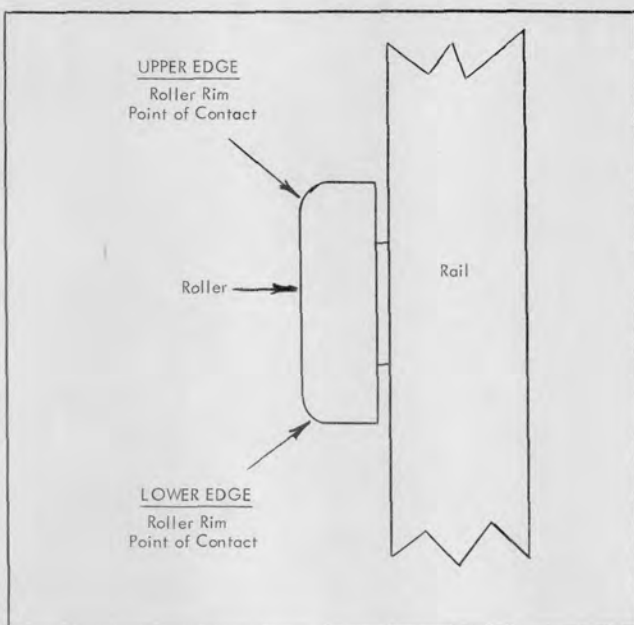

Plate 6325. Upright Roller

3. Move Inner Slide sideways to remove all clearance at opposite rail.

4. When checking clearance on the side that pry bar was installed, there must be some clearance between the Outer Rail and the bottom roller at the lower edge of the Roller Rim. THIS CLEARANCE SHOULD NOT EXCEED 1/32 INCH. If clearance is checked on opposite side, clearance should be checked between Outer Rail and bottom roller at the upper edge of Roller Rim, refer to Plate 6891 and 6325.

NOTE

THE BOTTOM ROLLERS OF THE INNER SLIDE, MUST BE CHECKED FOR CLEARANCE IN A 10 TO 20 INCH SECTION STARTING AT TOP OF OUTER RAIL ASSEMBLY, SEE Plate 6572.

5. Check clearance between Outer Rail Upper Rollers and Inner Slide. ROLLER CLEARANCE SHOULD BE CHECKED THE FULL LENGTH OF THE INNER SLIDE ASSEMBLY. Refer to Step 4 for Roller Clearance Specifications.

6. If adjustment is required, proceed as follows:

7. Disassemble upright.

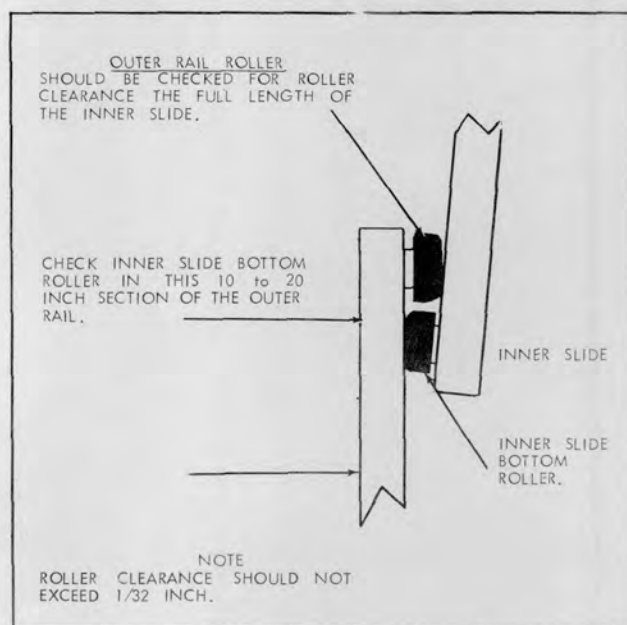

Plate 6572. Outer Rail Roller Clearance Check



INDUSTRIAL TRUCK DIVISION



LUBRICATION AND PREVENTIVE MAINTENANCE

8. Remove rollers from shafts and add or remove shims to acquire the clearance previously stated.

NOTE

THE ROLLER SHAFTS ARE WELDED TO THE RAIL ASSEMBLIES. TO REMOVE ROLLERS, MERELY PULL ROLLERS FREE OF ROLLER SHAFTS.

9. Reassembly upright.

10. Follow Steps 1 thru 5 and recheck clearance.

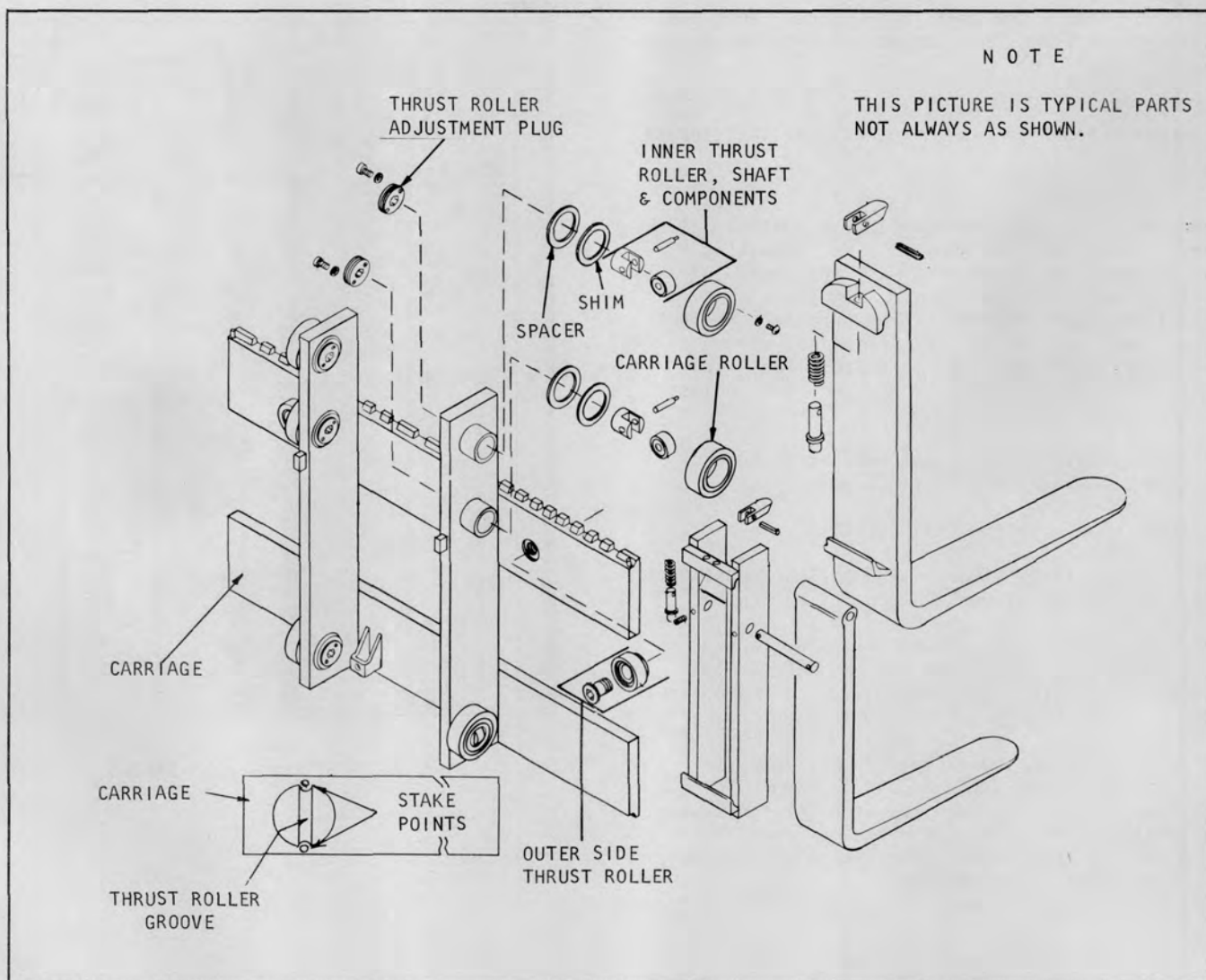

Plate 7705, Lift Carriage

LIFT CARRIAGE ROLLER ADJUSTMENTS

CARRIAGE MUST BE ADJUSTED SO IT IS HORIZONTAL AND CENTERED IN THE UPRIGHT FRAME. ROLLER CLEARANCE SHOULD BE CHECKED THE FULL LENGTH OF THE RAILS. ROLLERS SHOULD HAVE CLEARANCE OF NOT MORE THAN 1/32 INCH AT EACH SIDE

Outer Side Thrust Rollers

The Outer Side Thrust Rollers do not require adjustment. These should be replaced in the event of wear or damage. The

maximum clearance is 1/16 inch at each side.

Tighten the Outer Side Thrust Roller Shafts to 150 pound feet torque. The end of these shafts have a machined groove. Stake with a punch at each end of groove as shown in (Plate 7705.) This will secure shaft to lift carriage.

Inner Side Thrust Rollers

1. Check the clearance between the Inner Side Thrust Rollers and Inner Rails. Maximum allowable clearance is 1/32 inch or 1/64 inch at each side. Rollers must be free to rotate without binding. See Plate 7705.

2. Remove the retaining screw and the set screw from the thrust roller adjusting plug.

3. Turn the adjusting plug until the correct clearance is obtained on the thrust roller

The thrust roller shaft is so designed that the end facing the adjusting plug has three machined holes. The adjusting plug must be positioned so that one of its threaded holes is in registry with a machined hole on the thrust roller shaft. When the set screw is installed and securely tightened in this position, the adjusting plug cannot turn and its adjustment will be retained.

4. Install the retainer screw and tighten against the set screw

PISTON HEAD SLIDES AND GUIDES

Piston Head Slides and Guides should be lubricated every 100 operating hours.

Use "Lift Truck and Sliding Tandem Lubricant", Clark Part Number 886396. Complete instructions are given on lubricant can.

The piston head guides are of the replaceable type. If excessive wear is evident the flat head countersunk screws retaining the guides should be removed and new guides installed. Securely tighten screws after replacement.

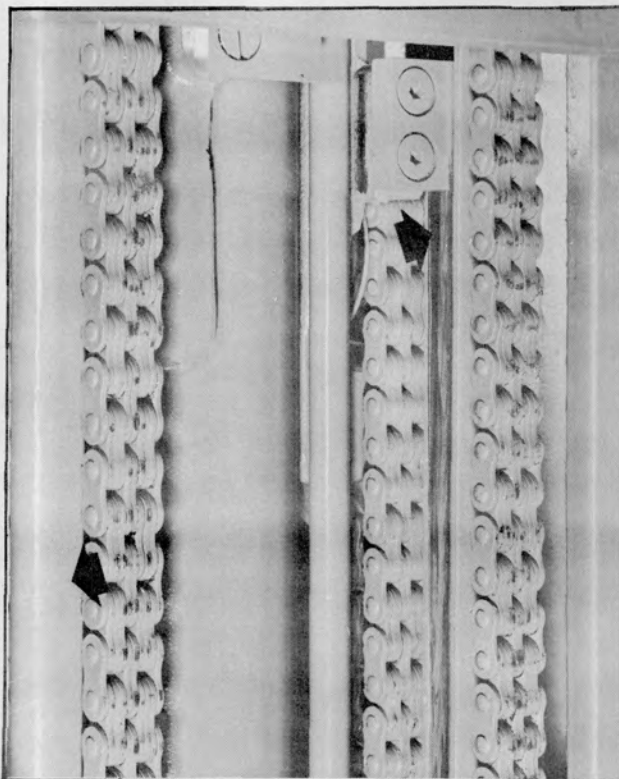

Plate 6319. Piston Head Slides

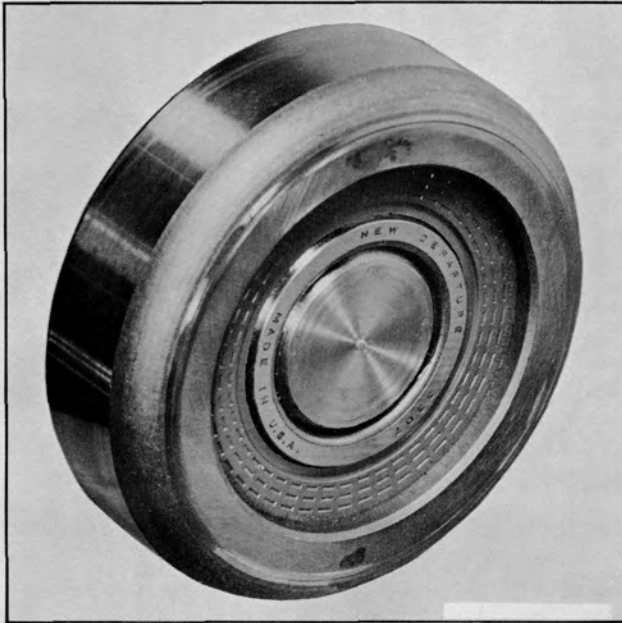

Plate 6323. Upright Roller

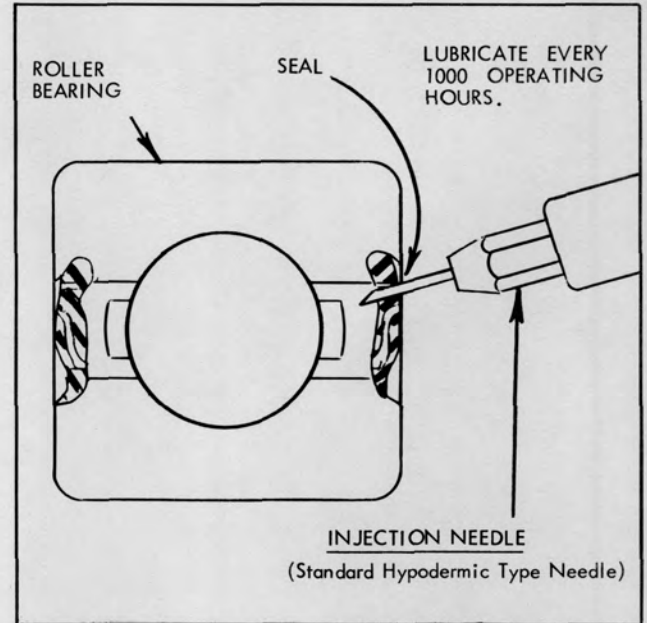

Plate 6328. Roller Bearing Lubrication

UPRIGHT ROLLER LUBRICATION

The manufacturer does not recommend removing a bearing seal for periodic lubrication.

Bearings are generally provided with four openings (on the bearings front face, between the waffle pattern) for lubrication with an Injection Needle.

This needle is a standard hypodermic type needle and can be purchased in drug stores, refer to Plate 6328.

A good light petroleum base oil should be used.

INDUSTRIAL TRUCK DIVISION

INSTRUCTION AND REFLECTIVE MARKING

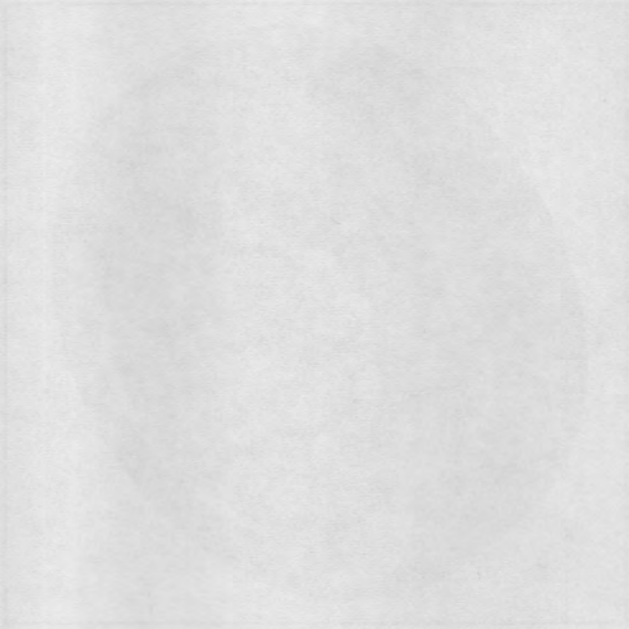
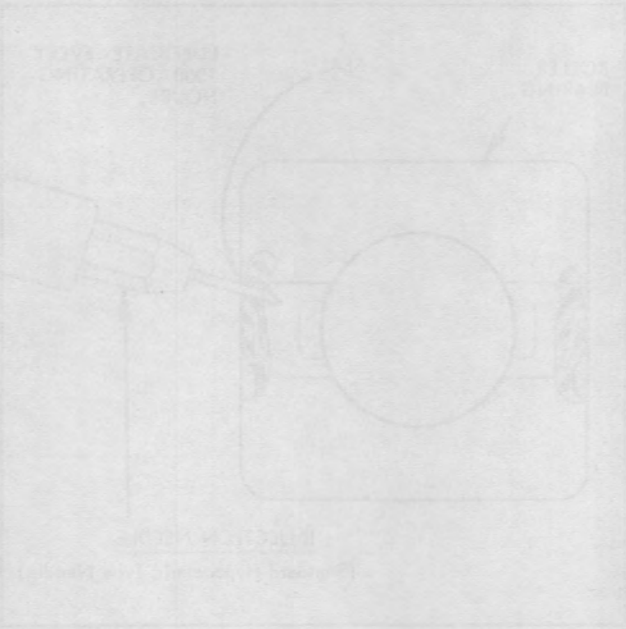



INDUSTRIAL TRUCK DIVISION



TROUBLE SHOOTING GUIDE

ENGINE

TROUBLE	PROBABLE CAUSE	REMEDY
Starting motor will not crank engine.	<p>Battery discharged</p> <p>Battery cable terminals loose or corroded. Ignition Fuse blown.</p> <p>Starting motor drive gear jammed in flywheel teeth.</p> <p>Improper oil.</p> <p>Battery cable terminal broken.</p> <p>Poor starting switch contacts.</p> <p>Faulty Neutral Starting Switch.</p>	<p>Recharge or replace battery.</p> <p>Remove and clean, reinstall and tighten cables. Replace fuse.</p> <p>Loosen starting motor and free-up gear.</p> <p>Change oil to proper grade.</p> <p>Replace cable.</p> <p>Replace switch.</p> <p>Refer to Starting Motor.</p>
Starting motor operates, but fails to crank engine when switch is engaged.	<p>Starting motor gear does not engage flywheel.</p> <p>Starting motor or drive gear defective.</p>	<p>Remove starting motor, and clean drive mechanism.</p> <p>Replace starting motor.</p>
<u>Engine will not start.</u> No spark. Ammeter shows no discharge (Zero reading) with ignition switch "on".	<p>Ignition switch partly "on".</p> <p>Ignition switch defective.</p> <p>Ignition primary wires or starting motor cables broken or connections loose.</p> <p>Ignition coil primary winding open.</p> <p>Distributor points dirty.</p> <p>Distributor points not closing.</p> <p>Loose or corroded ground, or battery cable connections.</p>	<p>Turn switch "on" fully.</p> <p>Replace switch.</p> <p>Repair, or replace and tighten.</p> <p>Replace coil.</p> <p>Clean and adjust points.</p> <p>Adjust or replace points.</p> <p>Remove and clean, reinstall and tighten cables.</p>
<u>Engine will not start.</u> Ammeter showing abnormal discharge with ignition switch "on".	<p>Defective condenser.</p> <p>Short-circuited or burned distributor cap or rotor.</p> <p>Short-circuited wire between ammeter and ignition switch.</p> <p>Short-circuited primary winding in ignition coil.</p> <p>Distributor points not opening.</p>	<p>Replace condenser.</p> <p>Replace parts.</p> <p>Repair or replace wire.</p> <p>Replace coil.</p> <p>Clean or replace, and adjust points.</p>
Weak spark.	<p>Distributor points pitted or burned.</p> <p>Distributor condenser weak.</p> <p>Ignition coil weak.</p>	<p>Clean or replace, and adjust points.</p> <p>Replace condenser.</p> <p>Replace coil.</p>



INDUSTRIAL TRUCK DIVISION



TROUBLE SHOOTING GUIDE

ENGINE (Continued)

TROUBLE	PROBABLE CAUSE	REMEDY
<p><u>Engine will not start.</u> Weak spark (continued)</p>	<p>Primary wire connections loose.</p> <p>High-tension, spark plug wires, or distributor cap wet.</p> <p>High-tension, spark plug wires, or distributor cap damaged.</p> <p>Distributor cap or rotor burned or broken.</p> <p>Spark plug gap incorrect.</p> <p>Short-circuited secondary circuit in coil.</p>	<p>Tighten.</p> <p>Dry thoroughly.</p> <p>Replace defective parts.</p> <p>Replace defective parts.</p> <p>Reset gaps.</p> <p>Replace coil.</p>
<p>Good spark.</p>	<p>Fuel tank empty.</p> <p>Dirt or water in carburetor, or float stuck.</p> <p>Carburetor and engine flooded by excessive use of choke.</p> <p>Fuel does not reach carburetor.</p> <p>Dirt in fuel lines or tank.</p> <p>Fuel line pinched.</p> <p>Ignition wires incorrectly installed in distributor cap.</p> <p>Ignition timing incorrect.</p> <p>Fuel Strainer Clogged.</p> <p>Fuel pump does not pump.</p> <p>Lack of engine compression.</p>	<p>Refill tank.</p> <p>Drain and clean carburetor.</p> <p>Depress accelerator pedal fully, crank engine with starting motor, when engine starts, reset throttle and leave choke control "in".</p> <p>Inspect for damaged or leaky lines or air leak into line between tank and fuel pump.</p> <p>Disconnect lines, drain tank, and blow out lines.</p> <p>Repair or replace line.</p> <p>Install wires correctly.</p> <p>Reset timing.</p> <p>Remove and clean strainer.</p> <p>Clean screen, replace pump if defective.</p> <p>Report to designated individual in authority.</p>
<p>Backfiring.</p>	<p>Ignition out of time.</p> <p>Spark plug wires incorrectly installed distributor cap or at spark plugs.</p> <p>Distributor cap cracked or shorted.</p> <p>Valve holding open.</p>	<p>Reset timing.</p> <p>Install wires correctly.</p> <p>Replace cap.</p> <p>Report to designated individual in authority.</p>



INDUSTRIAL TRUCK DIVISION



TROUBLE SHOOTING GUIDE

ENGINE (Continued)

TROUBLE	PROBABLE CAUSE	REMEDY
Engine operates, but backfires and spits.	Improper ignition timing.	Reset timing.
	Spark plug wires incorrectly installed in distributor cap.	Install wires correctly.
	Dirt or water in carburetor.	Drain and clean carburetor.
	Carburetor improperly adjusted.	Clean and adjust carburetor.
	Carburetor float level low.	Report to designated individual in authority.
	Valve sticking or not seating properly, burned or pitted.	Report to designated individual in authority.
	Excessive carbon in cylinders.	Remove carbon from cylinders.
	Valve springs weak.	Report to designated individual in authority.
	Heat control valve not operating.	Free-up, and adjust valve.
	Fuel pump pressure low.	Clean screen; replace pump, if defective.
	Fuel strainer clogged.	Remove and clean strainer.
	Partly clogged or pinched fuel lines.	Clean and repair lines.
	Intake manifold leak.	Inspect gaskets and tighten manifold stud nuts.
Distributor cap cracked or shorted.	Replace cap.	
Engine stalls on idle.	Carburetor throttle valve closes too far, or idle mixture incorrect.	Adjust carburetor.
	Carburetor choke valve remains closed.	Free-up and lubricate valve.
	Dirt or water in idler passages of Carburetor.	Clean or replace carburetor.
	Air leak at intake manifold.	Inspect gaskets and tighten manifold stud nuts.
	Heat control valve defective.	Free-up and adjust valve.
	Spark plugs defective, gaps incorrect.	Clean or replace spark plugs, set gap clearance.
	Ignition timing early.	Reset timing.
	Low compression.	Report to designated individual in authority.
	Water leak in cylinder head or head gaskets.	Replace gasket; report cylinder head leak to designated individual in authority.



INDUSTRIAL TRUCK DIVISION



TROUBLE SHOOTING GUIDE

ENGINE (Continued)

TROUBLE	PROBABLE CAUSE	REMEDY
Engine misfires on one or more cylinders.	<p>Dirty spark plugs.</p> <p>Spark plug gap incorrect.</p> <p>Cracked spark plug porcelain.</p> <p>Spark plug wires grounded.</p> <p>Spark plug wires incorrectly installed in cap or at spark plugs.</p> <p>Distributor cap or rotor burned or broken.</p> <p>Valve tappet holding valve open.</p> <p>Low engine compression.</p> <p>Leaky cylinder head gasket.</p> <p>Cracked cylinder block, broken valve tappet or tappet screw.</p>	<p>Clean, adjust, or replace plugs.</p> <p>Reset gap.</p> <p>Replace spark plug.</p> <p>Replace wires.</p> <p>Install wires correctly.</p> <p>Replace defective parts.</p> <p>Report to designated individual in authority.</p> <p>Report to designated individual in authority.</p> <p>Replace gasket.</p> <p>Report to designated individual in authority.</p>
Engine does not idle properly.	<p>Ignition timing.</p> <p>Dirty spark plugs, or gaps too close.</p>	<p>Reset timing.</p> <p>Clean and adjust spark plugs.</p>
Engine misses at high speeds.	<p>Ignition coil or condenser weak.</p> <p>Distributor points sticking, dirty or improperly adjusted.</p> <p>Distributor rotor or cap cracked or burned.</p> <p>Leaky cylinder head gaskets.</p> <p>Uneven cylinder compression.</p> <p>High-tension or spark plug wires leaky, cracked insulation.</p> <p>Carburetor choke not adjusted.</p> <p>Carburetor accelerating pump system defective, dirt in metering jets or float level incorrect.</p> <p>Fuel pump defective, causing lack of fuel.</p> <p>Air cleaner dirty.</p> <p>Heat control valve defective.</p>	<p>Replace defective parts.</p> <p>Clean, adjust, or replace points.</p> <p>Replace defective parts.</p> <p>Replace gaskets.</p> <p>Report to designated individual in authority.</p> <p>Replace defective parts.</p> <p>Adjust choke.</p> <p>Report to designated individual in authority.</p> <p>Clean screen, replace defective pump.</p> <p>Clean complete air cleaner and refill oil cup.</p> <p>Free-up and adjust</p>



INDUSTRIAL TRUCK DIVISION



TROUBLE SHOOTING GUIDE

ENGINE (Continued)

TROUBLE	PROBABLE CAUSE	REMEDY
Engine misses at high speeds. (continued)	<p>Valves sticking, weak or broken valve springs.</p> <p>Fuel strainer clogged.</p> <p>Weak distributor bracket arm spring</p> <p>Excessive play in distributor shaft bearing.</p> <p>Spark plugs defective, dirty or gap incorrectly set.</p>	<p>Report to designated individual in authority.</p> <p>Remove and clean strainer.</p> <p>Replace point set.</p> <p>Replace distributor.</p> <p>Clean, adjust or replace spark plugs.</p>
Engine pings (Spark Knock).	<p>Ignition timing early.</p> <p>Distributor automatic spark advance stuck in advance position, or spring broken.</p> <p>Excessive carbon deposit in cylinders.</p> <p>Incorrect fuel.</p>	<p>Reset timing.</p> <p>Replace distributor.</p> <p>Remove cylinder head and clean.</p> <p>Drain, use correct fuel.</p>
Engine lacks power.	<p>Ignition timing late.</p> <p>Incorrect fuel.</p> <p>Leaky cylinder head gasket.</p> <p>Excessive carbon formation.</p> <p>Engine runs cold.</p> <p>Insufficient oil, or improper grade oil.</p> <p>Oil system failure.</p> <p>Air Cleaner dirty.</p> <p>Spark plug gaps too wide.</p> <p>Choke valve partially closed, or throttle does not open fully.</p> <p>Manifold heat control inoperative.</p> <p>Exhaust pipe, muffler or tail pipe obstructed.</p> <p>Low compression, broken valve springs, sticking valves.</p>	<p>Reset timing.</p> <p>Use correct fuel.</p> <p>Replace gasket.</p> <p>Remove cylinder head, and clean cylinder head, piston heads, cylinder block, and valves.</p> <p>Test thermostat; in cold weather, cover radiator.</p> <p>Lubricate in accordance with lubrication section.</p> <p>Report to designated individual in authority.</p> <p>Clean complete air cleaner, change oil in cup. Reset gaps.</p> <p>Adjust valve or throttle.</p> <p>Free-up and adjust control.</p> <p>Service or replace obstructed parts.</p> <p>Report to designated individual in authority.</p>



INDUSTRIAL TRUCK DIVISION



TROUBLE SHOOTING GUIDE

ENGINE (Continued)

TROUBLE	PROBABLE CAUSE	REMEDY
Engine lacks power. (Continued)	Improper tappet adjustment. Lack of fuel.	Adjust tappets. Clean filter, inspect fuel pump, inspect carburetor for water or dirt and clean if necessary.
Engine overheats.	Cooling system deficient. Water low, air flow through radiator core restricted. Clogged radiator core (Clogged internally). Cylinder head gasket leaking. Radiator or water pump leaking. Damaged or deteriorated hose or fan belt. Loose fan belt. Cylinder block or head leaking. Ignition timing incorrect. Damaged muffler, bent or clogged exhaust pipe. Excessive carbon in cylinders. Insufficient oil, or improper grade. Air Cleaner restricted. Inoperative thermostat. Water pump impeller broken. Poor compression. Valve timing incorrect.	Clean radiator core from engine side with compressed air or water, or fill radiator to proper level. Clean by flushing radiator. Tighten cylinder head stud nuts and/or replace gasket. Repair or replace defective parts. Replace defective parts. Adjust fan belt tension. Report to designated individual in authority. Reset timing. Service or replace defective parts. Remove cylinder head, and clean cylinder head, piston heads cylinder block, and valves. Refer to Lubrication Instructions. Clean complete change oil in cup. Replace thermostat and gasket. Replace pump. Report to designated individual in authority. Reset timing.
High fuel consumption.	High engine speeds (Excessive driving in lower gear range). Air cleaner clogged. Carburetor float level too high, accelerating pump not properly adjusted. Fuel line leaks.	Correct driving practice. Clean complete air cleaner and change oil in cup. Report to designated individual in authority. Correct leaks, replace lines.

ENGINE (Continued)

TROUBLE	PROBABLE CAUSE	REMEDY
<p>High fuel consumption. (Continued)</p>	<p>Overheated engine.</p> <p>Carburetor parts worn or broken.</p> <p>Fuel pump pressure too high, or leaky diaphragm.</p> <p>Engine running cold.</p> <p>Ignition incorrectly timed.</p> <p>Spark advance stuck.</p> <p>Leaking fuel pump bowl gasket.</p> <p>Low compression.</p> <p>Carburetor controls sticking.</p> <p>Engine idles too fast.</p> <p>Spark plugs dirty.</p> <p>Weak coil or condenser</p> <p>Clogged muffler, or bent exhaust pipe.</p> <p>Loose engine mounts, permitting engine to shake and raise fuel level in carburetor.</p>	<p>See "Engine overheats".</p> <p>Replace fuel carburetor.</p> <p>Replace fuel pump.</p> <p>Inspect thermostat, cover radiator in winter.</p> <p>Reset timing.</p> <p>Replace distributor.</p> <p>Replace gasket.</p> <p>Report to designated individual in authority.</p> <p>Free-up and lubricate controls.</p> <p>Adjust carburetor throttle stop screw.</p> <p>Clean or replace spark plugs.</p> <p>Replace coil or condenser.</p> <p>Service or replace defective parts.</p> <p>Tighten; if damaged, replace defective mounts.</p>
<p>High oil consumption.</p>	<p>High engine speeds, or excessive driving in low gear range.</p> <p>Oil leaks.</p> <p>Improper grade oil, or diluted oil.</p> <p>Overheating of engine causing thinning of oil.</p> <p>Oil filter clogged.</p> <p>Defective piston or rings, excessive side clearance of intake valves in guides, cylinder bores worn (scored, out-of-round, tapered); excessive bearing clearance, misaligned connecting rods.</p>	<p>Correct driving practice.</p> <p>Replace leaking gaskets.</p> <p>Use new oil of proper grade.</p> <p>See "Engine overheats".</p> <p>Clean filter case thoroughly and replace element.</p> <p>Report to designated individual in authority.</p>



INDUSTRIAL TRUCK DIVISION



TROUBLE SHOOTING GUIDE

ENGINE (Continued)

TROUBLE	PROBABLE CAUSE	REMEDY
Low oil pressure.	<p>Insufficient oil supply.</p> <p>Improper grade of oil, or diluted oil foaming at high speeds.</p> <p>Oil too heavy (funneling in cold weather).</p> <p>Oil pump screen clogged.</p> <p>Oil leaks.</p> <p>Faulty oil pump, pressure regulator valve stuck or improperly adjusted, or spring broken.</p>	<p>Fill crankcase to prescribed level.</p> <p>Change oil, inspect crankcase ventilator, inspect for water in oil.</p> <p>Change to proper grade oil. (Refer to Lubrication Instructions.)</p> <p>Remove oil pan and clean pump screen.</p> <p>Report to designated individual in authority.</p> <p>Report to designated individual in authority.</p>
Defective valves.	<p>Incorrect tappet adjustment.</p> <p>Other valve troubles.</p>	<p>Adjust tappets.</p> <p>Report to designated individual in authority.</p>
Abnormal engine noises.	<p>Loose fan, fan pulley or belt, heat control valve.</p> <p>Leaking intake or exhaust manifold or gaskets, cylinder head gasket, or spark plugs.</p> <p>Overheated engine, clogged exhaust system.</p> <p>Other abnormal engine noises.</p>	<p>Tighten or correct conditions as required.</p> <p>Tighten loose components or replace defective gaskets.</p> <p>Remove obstruction from exhaust system. Inspect for further serviceability.</p> <p>Report to designated individual in authority.</p>
Poor compression.	<p>Incorrect tappet adjustment.</p> <p>Leaking, sticking, or burned valves; sticking tappets; valve spring weak or broken; valve stems and guides worn; piston ring grooves worn or rings worn, broken, or stuck; cylinder bores scored or worn.</p>	<p>Adjust tappets.</p> <p>Report to designated individual in authority.</p>

FUEL SYSTEM

TROUBLE	PROBABLE CAUSE	REMEDY
Fuel does not reach carburetor.	No fuel in fuel tank. Fuel pump inoperative. Fuel line air leak between tank and fuel pump. Fuel line clogged. Fuel tank cap vent clogged.	Fill fuel tank. Replace pump. Repair or replace line. Disconnect and blow out lines. Clean vent.
Fuel reaches carburetor, but does not reach cylinders.	Choke does not close. Fuel passage in carburetor clogged. Carburetor float valve stuck closed.	Free-up and lubricate, inspect for proper operation. Clean or replace carburetor. Report to designated individual in authority.
High fuel consumption.	Lubricant in power train too heavy. Incorrect adjustment of carburetor. Vehicle overloaded. Tires improperly inflated. Tight brakes.	Use correct lubricant. Adjust carburetor. Reduce loads to specified maximum capacity. Inflate tires properly. Adjust brakes.
Low fuel pressure.	Air leak in fuel lines. Fuel pump defective, diaphragm broken; valves leaking, linkage worn. Fuel lines clogged.	Tighten connections, repair lines if damaged. Replace fuel pump. Clean or replace lines.
Engine idles too fast.	Improper carburetor throttle stop adjustment. Carburetor control sticking. Control return spring weak.	Adjust throttle stop screw. Free-up and lubricate control. Replace spring.
Fuel gauge does not register.	Loose wire connection at instrument panel or tank unit. Instrument panel unit or tank unit inoperative.	Tighten connections. Replace unit.



INDUSTRIAL TRUCK DIVISION



TRUCKS - SHOVEL GUIDE

1974-1975

Model	Capacity	Weight
Model 100	1000 lbs	12000 lbs
Model 150	1500 lbs	18000 lbs
Model 200	2000 lbs	24000 lbs
Model 250	2500 lbs	30000 lbs
Model 300	3000 lbs	36000 lbs
Model 350	3500 lbs	42000 lbs
Model 400	4000 lbs	48000 lbs
Model 450	4500 lbs	54000 lbs
Model 500	5000 lbs	60000 lbs
Model 550	5500 lbs	66000 lbs
Model 600	6000 lbs	72000 lbs
Model 650	6500 lbs	78000 lbs
Model 700	7000 lbs	84000 lbs
Model 750	7500 lbs	90000 lbs
Model 800	8000 lbs	96000 lbs
Model 850	8500 lbs	102000 lbs
Model 900	9000 lbs	108000 lbs
Model 950	9500 lbs	114000 lbs
Model 1000	10000 lbs	120000 lbs
Model 1050	10500 lbs	126000 lbs
Model 1100	11000 lbs	132000 lbs
Model 1150	11500 lbs	138000 lbs
Model 1200	12000 lbs	144000 lbs
Model 1250	12500 lbs	150000 lbs
Model 1300	13000 lbs	156000 lbs
Model 1350	13500 lbs	162000 lbs
Model 1400	14000 lbs	168000 lbs
Model 1450	14500 lbs	174000 lbs
Model 1500	15000 lbs	180000 lbs
Model 1550	15500 lbs	186000 lbs
Model 1600	16000 lbs	192000 lbs
Model 1650	16500 lbs	198000 lbs
Model 1700	17000 lbs	204000 lbs
Model 1750	17500 lbs	210000 lbs
Model 1800	18000 lbs	216000 lbs
Model 1850	18500 lbs	222000 lbs
Model 1900	19000 lbs	228000 lbs
Model 1950	19500 lbs	234000 lbs
Model 2000	20000 lbs	240000 lbs
Model 2050	20500 lbs	246000 lbs
Model 2100	21000 lbs	252000 lbs
Model 2150	21500 lbs	258000 lbs
Model 2200	22000 lbs	264000 lbs
Model 2250	22500 lbs	270000 lbs
Model 2300	23000 lbs	276000 lbs
Model 2350	23500 lbs	282000 lbs
Model 2400	24000 lbs	288000 lbs
Model 2450	24500 lbs	294000 lbs
Model 2500	25000 lbs	300000 lbs
Model 2550	25500 lbs	306000 lbs
Model 2600	26000 lbs	312000 lbs
Model 2650	26500 lbs	318000 lbs
Model 2700	27000 lbs	324000 lbs
Model 2750	27500 lbs	330000 lbs
Model 2800	28000 lbs	336000 lbs
Model 2850	28500 lbs	342000 lbs
Model 2900	29000 lbs	348000 lbs
Model 2950	29500 lbs	354000 lbs
Model 3000	30000 lbs	360000 lbs
Model 3050	30500 lbs	366000 lbs
Model 3100	31000 lbs	372000 lbs
Model 3150	31500 lbs	378000 lbs
Model 3200	32000 lbs	384000 lbs
Model 3250	32500 lbs	390000 lbs
Model 3300	33000 lbs	396000 lbs
Model 3350	33500 lbs	402000 lbs
Model 3400	34000 lbs	408000 lbs
Model 3450	34500 lbs	414000 lbs
Model 3500	35000 lbs	420000 lbs
Model 3550	35500 lbs	426000 lbs
Model 3600	36000 lbs	432000 lbs
Model 3650	36500 lbs	438000 lbs
Model 3700	37000 lbs	444000 lbs
Model 3750	37500 lbs	450000 lbs
Model 3800	38000 lbs	456000 lbs
Model 3850	38500 lbs	462000 lbs
Model 3900	39000 lbs	468000 lbs
Model 3950	39500 lbs	474000 lbs
Model 4000	40000 lbs	480000 lbs
Model 4050	40500 lbs	486000 lbs
Model 4100	41000 lbs	492000 lbs
Model 4150	41500 lbs	498000 lbs
Model 4200	42000 lbs	504000 lbs
Model 4250	42500 lbs	510000 lbs
Model 4300	43000 lbs	516000 lbs
Model 4350	43500 lbs	522000 lbs
Model 4400	44000 lbs	528000 lbs
Model 4450	44500 lbs	534000 lbs
Model 4500	45000 lbs	540000 lbs
Model 4550	45500 lbs	546000 lbs
Model 4600	46000 lbs	552000 lbs
Model 4650	46500 lbs	558000 lbs
Model 4700	47000 lbs	564000 lbs
Model 4750	47500 lbs	570000 lbs
Model 4800	48000 lbs	576000 lbs
Model 4850	48500 lbs	582000 lbs
Model 4900	49000 lbs	588000 lbs
Model 4950	49500 lbs	594000 lbs
Model 5000	50000 lbs	600000 lbs



INDUSTRIAL TRUCK DIVISION



TROUBLE SHOOTING GUIDE

COOLING SYSTEM

TROUBLE	PROBABLE CAUSE	REMEDY
Overheating.	Unusual operating conditions of high temperature.	Inspect. (Refer to "Engine overheats".)
Loss of cooling solution.	Loose hose connections. Damaged or deteriorated hose. Leaking radiator.	Tighten hose connections. Replace hoses. Repair or replace radiator.
Engine operates too cool.	Thermostat sticking. Low air temperature.	Replace thermostat and gasket. Cover radiator.
Noises.	Frayed or loose fan belt. Water pump defective.	Replace or adjust belt. Replace pump.

INDUSTRIAL TRUCK DIVISION

TRUCK SHOWING BOARD

TRUCK YEAR

TRUCK

TRUCK MAKE

TRUCK MODEL

TRUCK MAKE

TRUCK MODEL

TRUCK YEAR

TRUCK MAKE

TRUCK MODEL

TRUCK YEAR

TRUCK MAKE

TRUCK MODEL

TRUCK YEAR

TRUCK MAKE

TRUCK MODEL

TRUCK YEAR

TRUCK MAKE

TRUCK MODEL

TRUCK YEAR

TRUCK MAKE

TRUCK MODEL

TRUCK YEAR

TRUCK MAKE

TRUCK MODEL

TRUCK YEAR

TRUCK MAKE

TRUCK MODEL

TRUCK YEAR

TRUCK MAKE

TRUCK MODEL

TRUCK YEAR

TRUCK MAKE

TRUCK MODEL

TRUCK YEAR

TRUCK MAKE

TRUCK MODEL

TRUCK YEAR

TRUCK MAKE

TRUCK MODEL

TRUCK YEAR

TRUCK MAKE

TRUCK MODEL

TRUCK YEAR

THE ENGINE COOLING SYSTEM

Trouble spots resulting from service neglect

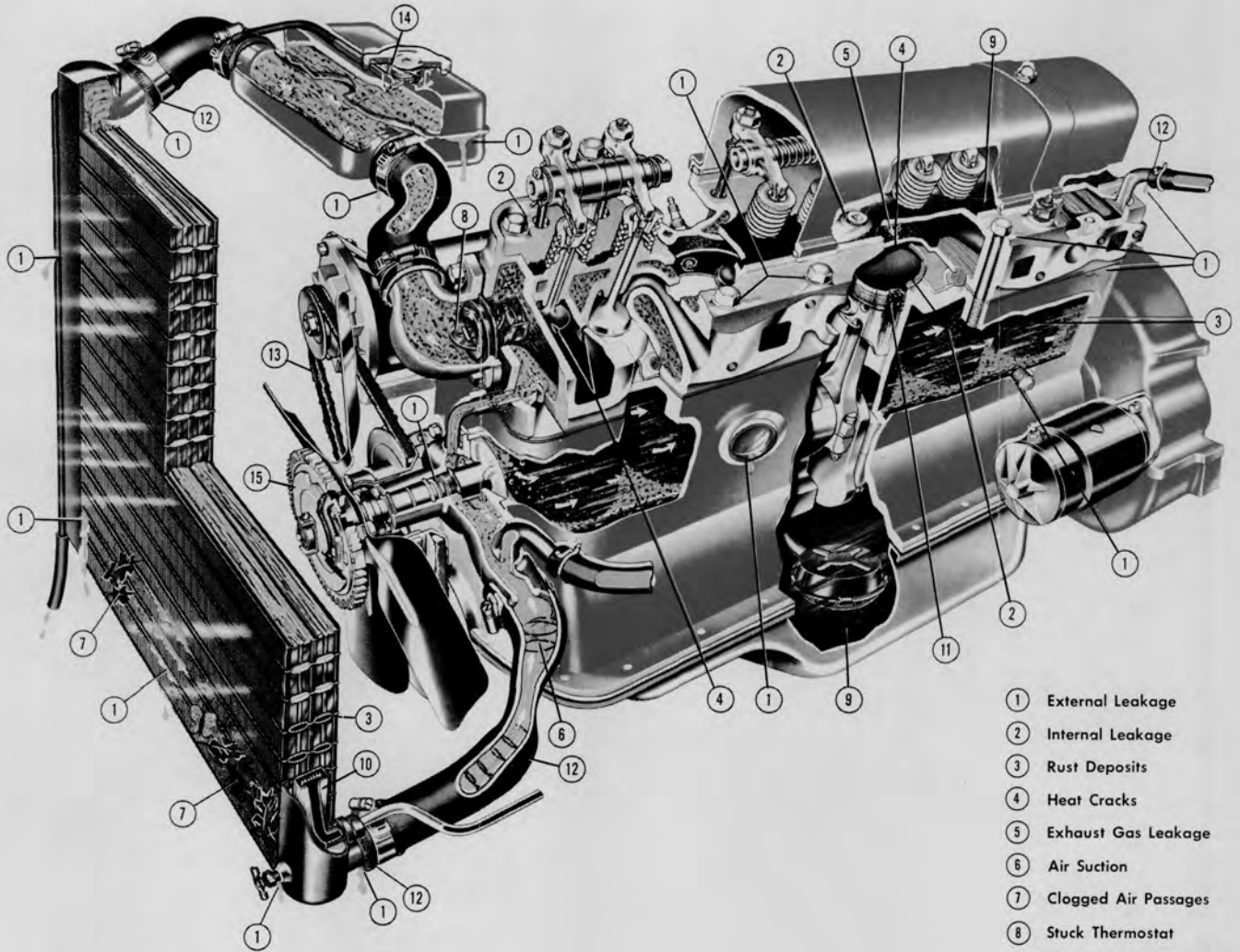

- ① External Leakage
- ② Internal Leakage
- ③ Rust Deposits
- ④ Heat Cracks
- ⑤ Exhaust Gas Leakage
- ⑥ Air Suction
- ⑦ Clogged Air Passages
- ⑧ Stuck Thermostat
- ⑨ Sludge Formation in Oil
- ⑩ Transmission Oil Cooler
- ⑪ Heat Damage
- ⑫ Hose Failure
- ⑬ Worn Fan Belt
- ⑭ Pressure Cap Leakage
- ⑮ Temperature Control Fan Drive

The cooling system depicted here does not represent that of any particular make of car; it incorporates features used by many different manufacturers.

All Rights Reserved.
No Part of This Chart May Be Reproduced Without Permission From Union Carbide Corporation.

Cooling System Care Pays!

This chart is distributed as a public service by
UNION CARBIDE CONSUMER PRODUCTS COMPANY
UNION CARBIDE Division of Union Carbide Corporation

THE ENGINE COOLING SYSTEM

Trouble spots resulting from service neglect



- 1. Fan belt
- 2. Fan blades
- 3. Fan housing
- 4. Radiator
- 5. Radiator cap
- 6. Radiator hoses
- 7. Water pump
- 8. Thermostat
- 9. Coolant level
- 10. Coolant quality

Check the fan belt for proper tension and condition. The fan blades should be clean and free of damage. The fan housing should be properly aligned with the fan blades. The radiator should be clean and free of debris. The radiator cap should be in good condition and the radiator hoses should be properly secured. The water pump should be checked for proper operation. The thermostat should be checked for proper operation. The coolant level should be checked and the coolant quality should be maintained.

Check System for Proper Operation

INDUSTRIAL TRUCK DIVISION
 P.O. BOX 1000
 MILWAUKEE, WIS. 53201

TROUBLE SHOOTING GUIDE

IGNITION SYSTEM

TROUBLE	PROBABLE CAUSE	REMEDY
Ignition system troubles.	<p>Weak spark.</p> <p>Timing incorrect.</p> <p>Moisture on distributor wires, coil, or spark plugs.</p> <p>Ignition switch inoperative.</p> <p>Primary or secondary wiring loose, broken, or grounded.</p> <p>Coil defective.</p> <p>Distributor defective.</p> <p>Spark plug defective.</p>	<p>Refer to "Engine will not start".</p> <p>Retime ignition.</p> <p>Clean and dry thoroughly.</p> <p>Replace switch.</p> <p>Service.</p> <p>Refer to "Ignition coil troubles", below.</p> <p>Refer to "Distributor troubles", below.</p> <p>Refer to spark plug troubles below.</p>
Ignition coil.	<p>Connections loose; dirty or broken external wire, wet.</p> <p>Coil defective.</p>	<p>Clean and tighten, or repair, dry thoroughly.</p> <p>Replace coil.</p>
Distributor troubles.	<p>Distributor breaker points dirty or pitted, point gaps incorrect.</p> <p>Distributor breaker point arm spring weak.</p> <p>Distributor breaker points sticking.</p> <p>Distributor automatic advance defective.</p> <p>Distributor cap or rotor shorted, cracked or broken.</p> <p>Distributor rotor does not turn.</p> <p>Condenser defective.</p>	<p>Clean, adjust or replace breaker points.</p> <p>Replace breaker point arm.</p> <p>Free-up breaker points.</p> <p>Lubricate and free-up. If seized, replace distributor.</p> <p>Replace defective parts.</p> <p>Report to designated individual in authority.</p> <p>Replace condenser.</p>
Spark plug troubles.	<p>Cracked, broken, leaking, or improper type.</p> <p>Spark plug wires incorrectly installed on plugs or in distributor cap.</p> <p>Spark plugs dirty; gap incorrect.</p> <p>Spark plug porcelain cracked or broken.</p>	<p>Replace spark plug.</p> <p>Install wires correctly.</p> <p>Clean, set gaps, or replace plugs.</p> <p>Replace plug.</p>



INDUSTRIAL TRUCK DIVISION



TROUBLE SHOOTING GUIDE

STARTING MOTOR

TROUBLE	PROBABLE CAUSE	REMEDY
Starting motor cranks engine slowly.	<p>Engine oil too heavy.</p> <p>Battery charge low.</p> <p>Battery cell shorted.</p> <p>Battery connections corroded, broken, or loose.</p> <p>Dirty commutator.</p> <p>Insufficient brush surface contact.</p> <p>Defective starting motor.</p> <p>Starting switch defective.</p>	<p>Change to proper grade oil.</p> <p>Recharge or replace battery.</p> <p>Replace battery.</p> <p>Clean and tighten, or replace cables.</p> <p>Clean commutator.</p> <p>Free-up or replace brush.</p> <p>Replace starting motor.</p> <p>Replace switch.</p>
Starting motor does not crank engine.	<p>Engine oil too heavy.</p> <p>Starting motor, solenoid, or cables defective; loose connections.</p> <p>Starting motor pinion gear jammed in flywheel drive gear.</p> <p>Dirty drive mechanism.</p> <p>Faulty Relay Switch.</p> <p>Ignition Fuse Blown.</p> <p>Faulty Ignition Switch.</p> <p>Faulty Neutral Starting Switch.</p>	<p>Change to proper grade oil.</p> <p>Replace or tighten loose connections.</p> <p>Remove starting motor and reinstall. Replace defective driving gear.</p> <p>Clean and lubricate drive mechanism.</p> <p>Replace Relay Switch.</p> <p>Replace Fuse.</p> <p>Replace Switch.</p> <p>Replace Switch. NOTE: The INDEX of this manual will list an ADJUSTABLE Neutral Starting Switch if your machine is so equipped.</p>

INDUSTRIAL TRUCK DIVISION

TRUCKS AND TRUCKS

TRUCKS AND TRUCKS

PROPERTY	DESCRIPTION	REMARKS
<p>Change in property...</p> <p>...</p>	<p>...</p> <p>...</p>	<p>...</p> <p>...</p>
<p>...</p> <p>...</p>	<p>...</p> <p>...</p>	<p>...</p> <p>...</p>
<p>...</p> <p>...</p>	<p>...</p> <p>...</p>	<p>...</p> <p>...</p>
<p>...</p> <p>...</p>	<p>...</p> <p>...</p>	<p>...</p> <p>...</p>



INDUSTRIAL TRUCK DIVISION



TROUBLE SHOOTING GUIDE

GENERATOR TROUBLES

TROUBLE	PROBABLE CAUSE	REMEDY
No output.	Regulator defective.	Replace regulator.
Low or fluctuating output.	Loose fan belt. Insufficient brush surface contact. Weak brush springs. Worn commutator. Broken or loose connections. Dirty commutator. Regulator defective. Loose or dirty connections in charging circuit.	Adjust belt. Free-up or replace brush. Replace spring. Report to designated individual in authority. Repair, tighten or replace. Clean commutator. Replace regulator. Clean and tighten connections.
Excessive output.	Short circuit between field coil and armature leads. Regulator defective.	Replace generator. Replace regulator.
Noisy.	Loose pulley or generator mounting. Defective bearings, or armature rubbing on field poles. Improperly seated brushes.	Tighten. Replace generator. Seat brushes.
Generator regulator troubles.	Loose connections or mountings. Defective regulator.	Clean and tighten. Replace regulator.

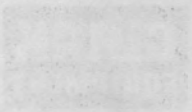

INDUSTRIAL TRUCK DIVISION



MODEL SHEETING GUIDE

FOR THE TRUCKS

TRUCK

TRUCK

TRUCK

Truck models

Truck models

Truck models

Truck models

Truck models

Truck models

Truck models

Truck models

Truck models

Truck models

Truck models

Truck models

Truck models

Truck models

Truck models

Truck models

Truck models

Truck models

Truck models

Truck models

Truck models

Truck models

Truck models

Truck models

Truck models

Truck models

Truck models

Truck models

Truck models

Truck models

Truck models

Truck models

Truck models

Truck models

TROUBLE SHOOTING GUIDE

BATTERY, LIGHTS AND HORN

TROUBLE	PROBABLE CAUSE	REMEDY
Battery discharged.	<p>Battery solution level low.</p> <p>Short in battery cell.</p> <p>Generator not charging.</p> <p>Loose or dirty connections; broken cables.</p> <p>Excessive use of starting motor.</p> <p>Idle battery, or excessive use of lights with engine at idle.</p> <p>Short circuits.</p>	<p>Add distilled water to bring level above plates; inspect for cracked case.</p> <p>Replace battery.</p> <p>Inspect generator, fan belt, and regulator.</p> <p>Clean and tighten connections; replace cables.</p> <p>Tune up engine; charge battery.</p> <p>Recharge or replace battery. Use lights sparingly.</p> <p>Replace defective wiring.</p>
Battery (other troubles)	<p>Overheated battery.</p> <p>Case bulged (or out of shape).</p>	<p>Inspect for short circuit or excessive generator charge.</p> <p>Inspect for overcharging and over-tightening of hold-down screws.</p>
Light switch.	<p>Loose or dirty connections; broken wire.</p> <p>Defective switch.</p>	<p>Clean and tighten; replace broken wire.</p> <p>Replace switch.</p>
Wiring.	<p>Loose or dirty connections; broken wire or terminal.</p>	<p>Clean, tighten, repair or replace. Wire or terminal.</p>
Lights do not light.	<p>Switch not fully "on".</p> <p>Loose or dirty connections; broken wire.</p> <p>Wiring circuit short-circuited, or open.</p> <p>Light burned out.</p>	<p>Turn switch "on" fully.</p> <p>Clean and tighten; replace or repair wire or terminal.</p> <p>Correct short circuit or replace defective parts.</p> <p>Replace light.</p>
Lights dim.	<p>Loose or dirty connection.</p> <p>Wiring short-circuited.</p> <p>Defective switch.</p>	<p>Clean and tighten connections.</p> <p>Correct short circuit or replace defective parts.</p> <p>Replace switch.</p>



INDUSTRIAL TRUCK DIVISION



TROUBLE SHOOTING GUIDE

BATTERY, LIGHTS AND HORN (Continued)

TROUBLE	PROBABLE CAUSE	REMEDY
Horn troubles.	Loose or dirty wiring connections.	Clean and tighten connections.
Horn sounds continuously.	Short-circuit in wiring between horn and horn button.	Replace wire.
Improper tone.	Loose or dirty wiring connections. Cover or bracket screws loose. Points adjusted improperly.	Clean and tighten connections. Tighten. Adjust points.
Horn will not operate.	Horn Fuse Blown. Open Circuit. Faulty Horn Relay.	Replace Fuse. Trace, repair or replace as required. Replace relay.

TROUBLE SHOOTING GUIDE

DRIVE AXLE

TROUBLE	PROBABLE CAUSE	REMEDY
Continuous Axle Noise.	<p>Badly worn parts.</p> <p>Unevenly worn tires.</p> <p>Improperly adjusted wheel bearing.</p> <p>Lack of lubricant.</p>	<p>Replace worn parts with new.</p> <p>Replace tires.</p> <p>Adjust correctly.</p> <p>Add sufficient lubricant of correct grade.</p>
Axle Noise on Drive or on Coast Only.	Differential pinion gear and ring gear out of adjustment or worn excessively.	Adjust, repair or replace entire unit if conditions warrants.
Excessive Backlash in Axle Driving.	<p>Loose axle shaft drive flange cap screws.</p> <p>Flange loose on axle shaft.</p> <p>Worn splines on axle shaft at differential end.</p> <p>Differential drive pinion gear and ring gear out of adjustment or worn excessively.</p>	<p>Tighten cap screws.</p> <p>Reweld flange to shaft.</p> <p>Replace drive flange and shaft assembly.</p> <p>Adjust or replace as condition warrants.</p>
Complete Failure to Function.	<p>Broken axle shaft.</p> <p>Broken teeth on ring gear or pinion gear.</p>	<p>Replace axle shaft.</p> <p>Replace ring gear and pinion and other parts of differential necessary. Adjust ring gear and pinion gear correctly.</p>

INDUSTRIAL TRUCK DIVISION

MODEL FOOTING GUIDE

CLASS	MODEL	FOOTING
Class 1	Model 100	Footings 100-100
Class 2	Model 200	Footings 200-200
Class 3	Model 300	Footings 300-300
Class 4	Model 400	Footings 400-400
Class 5	Model 500	Footings 500-500
Class 6	Model 600	Footings 600-600
Class 7	Model 700	Footings 700-700
Class 8	Model 800	Footings 800-800
Class 9	Model 900	Footings 900-900
Class 10	Model 1000	Footings 1000-1000



INDUSTRIAL TRUCK DIVISION



TROUBLE SHOOTING GUIDE

STEERING AXLE

TROUBLE	PROBABLE CAUSE	REMEDY
Trouble.	Damaged axle. Lubrication leaks. Incorrect caster or camber. Uneven tire wear.	Replace axle. Replace oil seals. (Refer to Lubrication Section). Report to designated individual in authority. Report to designated individual in authority. Inflate tires properly. Check wheel alignment.

INDUSTRIAL TRUCK DIVISION



THE UNIT SHOOTING UNIT

THE UNIT SHOOTING UNIT

NAME	UNIT	ADDRESS
John Doe	1st Unit	123 Main St
Jane Smith	2nd Unit	456 Elm St
Robert Johnson	3rd Unit	789 Oak St
Mary White	4th Unit	101 Pine St
David Brown	5th Unit	202 Cedar St
Susan Green	6th Unit	303 Birch St
Michael Black	7th Unit	404 Spruce St
Elizabeth Gray	8th Unit	505 Willow St
James King	9th Unit	606 Ash St
Patricia Lee	10th Unit	707 Hickory St
Christopher Hall	11th Unit	808 Sycamore St
Jennifer Adams	12th Unit	909 Dogwood St
Daniel Miller	13th Unit	1010 Magnolia St
Michelle Taylor	14th Unit	1111 Redwood St
Andrew Wilson	15th Unit	1212 Cypress St
Stephanie Moore	16th Unit	1313 Juniper St
Jonathan Taylor	17th Unit	1414 Fir St
Nicole Anderson	18th Unit	1515 Spruce St
Kevin Thomas	19th Unit	1616 Cedar St
Amanda Jackson	20th Unit	1717 Birch St



INDUSTRIAL TRUCK DIVISION



TROUBLE SHOOTING GUIDE

STEERING

TROUBLE	PROBABLE CAUSE	REMEDY
Steering difficult.	Lack of lubrication Tight steering system connections. Tight steering gear; misaligned wheels. Bent steering connecting linkage or arm. Misaligned steering gear mounting.	Lubricate. Lubricate and adjust linkage. Report to designated individual in authority. Straighten or replace linkage. Adjust mounting.
Wander or weaving.	Improper toe in camber or caster (axle twisted). Steering system connections or king pin bearings not properly lubricated. Loose wheel bearings. Steering gear worn or maladjusted. Steering gear mountings loose.	Report to designated individual in authority. Lubricate. Adjust wheel bearings. Report to designated individual in authority. Tighten mounting bolts.
Low speed shimmy or wobble.	Loose steering connections. Steering gear worn, or adjustment too loose. Loose wheel bearings.	Adjust and tighten linkage. Report to designated individual in authority. Adjust wheel bearings.
Vehicle pulls to one side.	Odd size, or new and old tires on opposite wheels. Tight wheel bearings. Bent steering arm or connection.	Match tires. Adjust. Lubricate wheel bearings. Straighten or replace bent linkage.

INDUSTRIAL TRUCK DIVISION

TRUCK MODELING GUIDE

Model	Capacity	Dimensions	Weight	Speed	Maneuverability	Maneuverability	Maneuverability	Maneuverability	Maneuverability
Model 100	1000 lbs	100" x 40" x 60"	1000 lbs	10 mph	High	High	High	High	High
Model 200	2000 lbs	120" x 45" x 65"	2000 lbs	15 mph	Medium	Medium	Medium	Medium	Medium
Model 300	3000 lbs	140" x 50" x 70"	3000 lbs	20 mph	Low	Low	Low	Low	Low
Model 400	4000 lbs	160" x 55" x 75"	4000 lbs	25 mph	Very Low	Very Low	Very Low	Very Low	Very Low
Model 500	5000 lbs	180" x 60" x 80"	5000 lbs	30 mph	None	None	None	None	None
Model 600	6000 lbs	200" x 65" x 85"	6000 lbs	35 mph	None	None	None	None	None
Model 700	7000 lbs	220" x 70" x 90"	7000 lbs	40 mph	None	None	None	None	None
Model 800	8000 lbs	240" x 75" x 95"	8000 lbs	45 mph	None	None	None	None	None
Model 900	9000 lbs	260" x 80" x 100"	9000 lbs	50 mph	None	None	None	None	None
Model 1000	10000 lbs	280" x 85" x 105"	10000 lbs	55 mph	None	None	None	None	None

BRAKES

TROUBLE	PROBABLE CAUSE	REMEDY
Brakes drag.	Improper pedal adjustment. Brake pedal return spring broken or weak. Brakes improperly adjusted. Brake shoe anchor pin tight in shoe. Brake shoe return spring broken or weak. Loose or damaged wheel bearings. Insufficient brake shoe clearance, or improper brake anchor pin adjustment. Brake backing plate loose. Grease on linings. Dirt imbedded in lining. Drums scored or rough.	Adjust brake pedal free travel. Replace spring. Adjust brakes. Free-up pin and lubricate lightly. Replace spring. Adjust or replace wheel bearings. Adjust brakes. Tighten plate. Correct grease leakage; clean or install new shoes and lining assemblies. Clean lining with wire brush. Replace drum and brake shoe and lining assemblies.
Severe brake action on light pedal pressure.	Brake shoes improperly adjusted. Grease on linings. Loose brake shoe anchor.	Adjust brakes. Correct grease leakage; clean or install new shoes and lining assemblies. Adjust and tighten.
Brake locked.	Brake pedal lacks free travel. Brakes frozen to drums (cold weather).	Adjust pedal free travel. Break loose by driving vehicle.
Brake noisy or chatters.	Brake lining worn. Grease on linings. Dirt embedded in linings. Improper or loose linings. Brake shoe or drum distorted.	Replace shoe and lining assemblies. Correct leakage; clean or replace shoe and lining assemblies. Clean lining with wire brush. Replace shoe and lining assemblies. Straighten or replace.



INDUSTRIAL TRUCK DIVISION



TROUBLE SHOOTING GUIDE

BRAKES (Continued)

TROUBLE	PROBABLE CAUSE	REMEDY
Excessive pedal travel.	Lining worn. Brake improperly adjusted. Scored brake drums.	Adjust or replace shoe and lining assemblies. Adjust brake. Repair or replace drums.
Excessive pedal pressure.	Grease on linings; worn or glazed lining. Warped brake shoes, or defective brake linings. Shoes improperly adjusted. Brake drum scored or distorted. Shoes improperly adjusted. Insufficient fluid in master cylinder.	Correct grease leakage; clean up and replace shoe and lining assemblies. Replace shoe and lining assemblies. Adjust brakes. Repair or replace drums. Adjust brakes. Fill master cylinder to within 1/4 inch of the top.
Wheel troubles.	Wheel wobbles; bent. Wheel loose on hub. Wheel out of balance. Wheel bearings run hot.	Inspect mounting on hub, spindles, and drive axle; replace defective wheel or mounting. Tighten. Balance wheel. Adjust, lubricate wheel bearings.



INDUSTRIAL TRUCK DIVISION



TROUBLE SHOOTING GUIDE

HYDRAULIC SYSTEM

TROUBLE	PROBABLE CAUSE	REMEDY
Pump not delivering oil.	<p>Wrong direction *of rotation.</p> <p>Tank oil level low.</p> <p>Oil intake pipe or suction filter plugged.</p> <p>Air leak in suction line.</p> <p>Oil viscosity too heavy to pick up prime.</p> <p>Broken pump shaft or gear.</p>	<p>Must be reversed immediately to prevent seizure and breakage of parts due to lack of oil.</p> <p>Add recommended oil.</p> <p>Replace filter cartridge, clean strainer if so equipped.</p> <p>Will prevent priming, or cause noise and irregular action of control circuit.</p> <p>Thinner oil should be used, per recommendations for given perature and service.</p> <p>Report to designated individual in authority.</p>
Pump not developing pressure.	<p>Pump not delivering oil for any of the above reasons.</p> <p>Relief valve setting not high enough.</p> <p>Relief valve sticking open.</p> <p>Leak in hydraulic control system (cylinders or valves).</p> <p>Partially clogged intake line, intake filter or restricted intake pipe.</p>	<p>Check oil circulation by watching oil in tank.</p> <p>Refer to relief valve instructions.</p> <p>Dirt under pressure adjustment valve. Refer relief valve instructions.</p> <p>Find leak and correct.</p> <p>Pump must receive intake oil freely or cavitation will take place.</p>
Pump making noise.	<p>Small air leak at pump intake piping joints.</p> <p>Air leak at pump shaft packing.</p> <p>Tank air vent plugged.</p> <p>Too high oil viscosity.</p> <p>Shaft packing worn.</p> <p>Oil filter dirty.</p>	<p>Test by pouring oil on joints while listening for change in operation. Tighten as required.</p> <p>Repair or replace.</p> <p>Must be open thru breather opening or air filter.</p> <p>Use recommended oils.</p> <p>Replace shaft packing per preceding instructions.</p> <p>Replace filter element.</p>
Forks do not lift to maximum height.	Hydraulic Oil level low.	Fill sump tank.



INDUSTRIAL TRUCK DIVISION



TROUBLE SHOOTING GUIDE

HYDRAULIC SYSTEM CONTINUED

TROUBLE	PROBABLE CAUSE	REMEDY
Lift or tilt action fails.	Loss of oil pressure.	Report to designated individual in authority.
Oil leak at top of lift cylinder assembly.	Worn or damaged lift piston seal. Scored cylinder wall. Plugged vent line.	Replace seal. Replace cylinder. Clean out vent line. Replace if collapsed.
Oil leak around piston rod at tilt cylinder.	Worn seal. Scored piston rod.	Replace seal. Replace rod and eliminate cause of scoring which may be caused by misalignment, worn bearing or foreign matter.
With load centered on lift forks load is lifted unevenly.	Lift chains out of adjustment.	Adjust chains.



INDUSTRIAL TRUCK DIVISION



TROUBLE SHOOTING GUIDE

TRANSMISSION, CONVERTER AND AXLE ADAPTOR (HYDRATORK DRIVE)

TROUBLE	PROBABLE CASE	REMEDY
Machine will not move in either direction.	<p>Parking Brake not released.</p> <p>Control Linkage not Properly adjusted.</p> <p>Oil level low.</p> <p>No oil pressure.</p>	<p>Release brake.</p> <p>Readjust linkage.</p> <p>Determine cause and correct. Fill to proper level with Type "A" Automatic Transmission Fluid Armour Qualified.</p> <p>Report to designated person in authority.</p>
Machine will move in one direction only.	<p>Control linkage not adjusted.</p> <p>No oil pressure to Directional Selector. Seals and "O" Rings in Directional Selector may be defective.</p> <p>Directional Selector Discs not releasing. Discs defective. Relief hole in D.S. Drum clogged.</p>	<p>Adjust linkage.</p> <p>Report to designated person in authority.</p> <p>Report to designated person in authority.</p>
Machine moves slowly in both directions at wide open throttle.	<p>Oil level low.</p> <p>Low oil pressure. Faulty Inching Valve, Faulty Relief Valve, Faulty Pump.</p> <p>Brakes dragging.</p> <p>Clogged Sump Screen.</p>	<p>Fill to correct level and determine cause for loss of oil.</p> <p>Report to designated person in authority.</p> <p>Report to designated person in authority.</p> <p>Clean Screen.</p>
Transmission overheating.	<p>Low oil.</p> <p>Low Directional Selector pressure (check with gauge). Inching valve not functioning properly.</p> <p>Seals in selector defective.</p> <p>Regulating valve sticking open.</p> <p>Brakes Dragging.</p> <p>Clogged Sump Screen.</p>	<p>Check and fill to correct level.</p> <p>Report to designated person in authority.</p> <p>Report to designated person in authority.</p> <p>Report to designated person in authority.</p> <p>Report to designated person in authority.</p> <p>Clean Screen.</p>



INDUSTRIAL TRUCK DIVISION



TROUBLE SHOOTING GUIDE

TRANSMISSION, CONVERTER AND AXLE ADAPTOR (HYDRATORK DRIVE)

TROUBLE	PROBABLE CAUSE	REMEDY
Transmission Overheating (Continued)	Insufficient oil to Torque Converter and Cooler. Cooler clogged internally stopping flow of oil. Bushing in Torque Converter Impeller Hub worn, allowing oil to leak out. Slipping Stator.	Report to designated person in authority. Clean Cooler. Report to designated person in authority. Refer to Transmission Pressure Checks
Machine has full power and overheats.	Overloading machine. Radiator core clogged externally. Pressure Regulator Valve sticking, giving low pressure.	Check Capacity Loads. Never overload. Clean Core. Report to designated person in authority.

