



INDUSTRIAL TRUCK DIVISION



OPERATORS MANUAL

FOR

NST 15 / 20 / 25 / 30 / 40

1st REVISION

0-165

CLARK EQUIPMENT COMPANY

PUBLISHED BY

TECHNICAL SERVICE DEPARTMENT,
BATTLE CREEK, MICHIGAN, U.S.A.

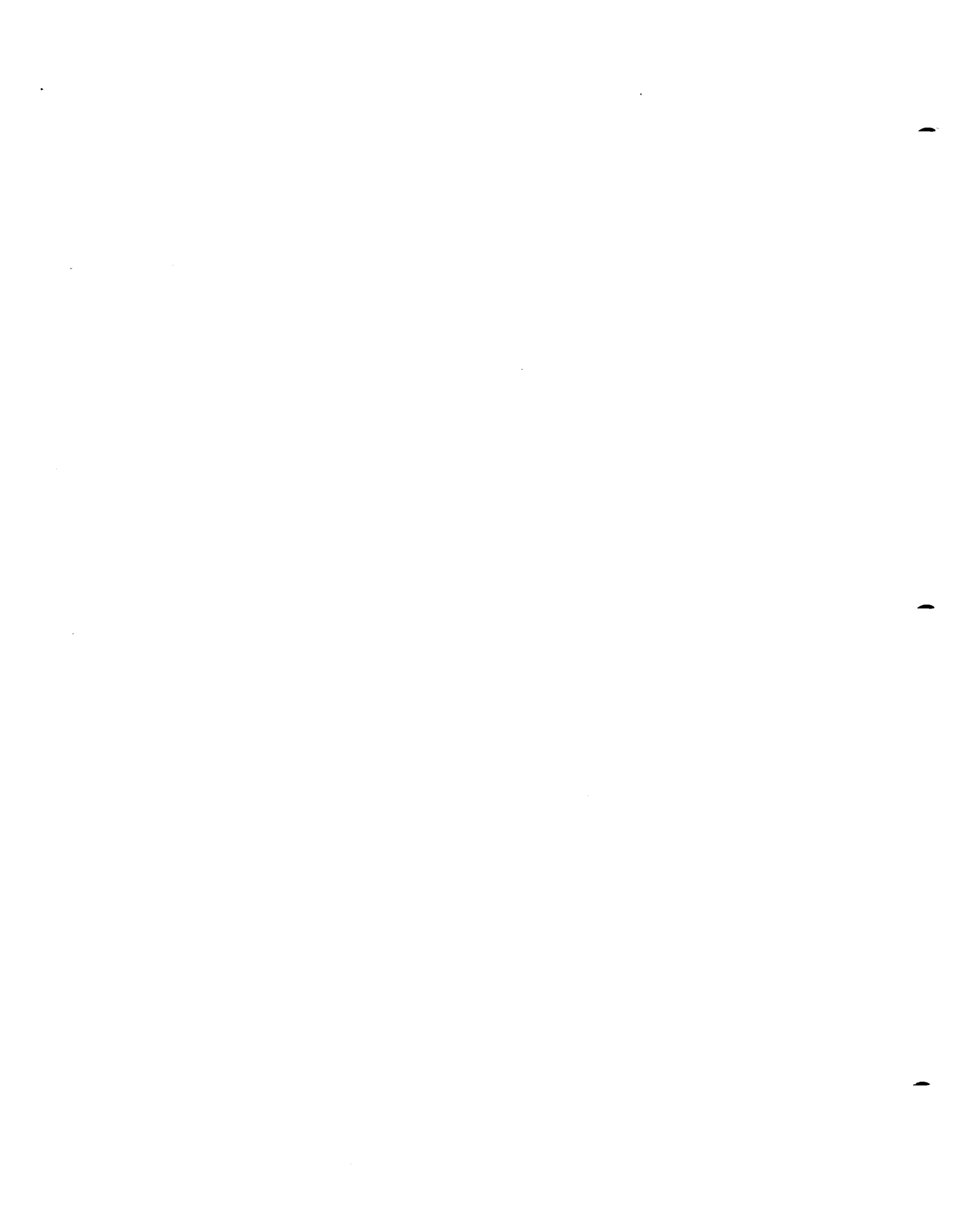

SAFETY INSTRUCTIONS FOR MAINTAINING INDUSTRIAL TRUCKS

Powered industrial trucks may become hazardous if adequate maintenance is neglected. Therefore, adequate maintenance facilities, personnel and procedures should be provided.

Maintenance and inspection of all powered industrial trucks should be performed in conformance with the recommendation in this manual and the following practices.

1. A scheduled preventive maintenance, lubrication, and inspection system should be followed.
2. Only qualified and authorized personnel should be permitted to maintain, repair, adjust, and inspect industrial trucks.
3. Before Leaving The Truck:

- A. Stop truck.
- B. Fully lower the load engaging means.
- C. Place directional controls in neutral.
- D. Apply the parking brake.
- E. Stop the engine or turn off power.
- F. Lock the control or ignition circuit.
- G. Block the wheels if truck is on a ramp, or being worked on.

4. Before Working On Truck:

- A. Raise wheels free of floor or disconnect power source.
- B. Use chocks or other positive truck positioning devices.
- C. Block load engaging means, innermast(s), or chassis before working under them.

Before working on engine fuel system of gasoline powered trucks with gravity feed fuel systems, be sure fuel shutoff valve is closed.

Before working on engine fuel system of LP gas powered trucks, close LP gas cylinder valve and run engine until fuel in system is depleted and engine stops running.

Operation to check performance of the truck or attachments should be conducted in an authorized, safe clearance area.

5. Before Starting To Operate The Truck:

- A. Be in operating position.
- B. Depress clutch (or brake pedal on automatic transmission and electric trucks).
- C. Place directional controls in neutral.
- D. Start engine or turn on power.
- E. Before operating truck, check functioning of lift and tilt systems, directional and speed controls, steering, warning devices, brakes, and any attachment. (If used)
- F. Release parking brake.

- continued -

SAFETY INSTRUCTIONS FOR MAINTAINING INDUSTRIAL TRUCKS

6. Avoid fire hazards and have fire protection equipment present. Do not use an open flame to check level, or for leakage, of fuel, electrolyte or coolant. Do not use open pans of fuel or flammable cleaning fluids for cleaning parts.
7. Properly ventilate work area, vent exhaust fumes and keep shop clean and floor dry.
8. Handle LP gas cylinders with care. Do not drop, dent, or damage in any way.
9. Brakes, steering mechanisms, control mechanisms, warning devices, lights, governors, lift overload devices, guards and safety devices should be inspected regularly and maintained in a safe operating condition.
10. All parts of lift and tilt mechanisms and frame members should be carefully and regularly inspected and maintained in a safe operating condition.
11. Special trucks or devices designed and approved for hazardous area operation should receive special attention to ensure that maintenance preserves the original, approved safe operating features.
12. Fuel systems should be checked for leaks and condition of parts. Extra special consideration should be given in the case of a leak in the fuel system. Action should be taken to prevent the use of the truck until the leak has been corrected.
13. All hydraulic systems should be regularly inspected and maintained in conformance with good practice. Tilt cylinders, valves, and other similar parts should be checked to assure that "drift" has not developed to the extent that it would create a hazard.
14. Capacity, operation and maintenance instructions plates, tags, or decals should be maintained in legible condition.
15. Batteries, motors, controllers, limit switches, protective devices, electrical conductors and connections should be inspected and maintained in conformance with good practice. Special attention should be paid to the condition of electrical insulation.
16. Industrial trucks should be kept in a clean condition to minimize fire hazards and facilitate detection of loose or defective parts.
17. Modifications and additions which affect capacity and safe truck operation should not be performed by the customer or user without manufacturers prior written approval. Capacity, operation and maintenance instruction plates, tags or decals should be changed accordingly.
18. Care should be taken to assure that all replacement parts are interchangeable with the original parts and of a quality equal to that provided in the original equipment.



INDUSTRIAL TRUCK DIVISION



PLEASE NOTE

INSTRUCTIONS ON USE OF MANUAL

This Operator's Manual is published as a service reference guide and includes Specifications, Operating Instructions, Lubrication and Preventive Maintenance Instructions, and Trouble Shooting Guide.

The TABLE OF CONTENTS for this manual is printed on green paper and is placed at the front for easy reference. A separate INDEX (also printed on green paper) is placed in front of the Lubrication and Preventive Maintenance Section.

Lubrication and Preventive Maintenance Instructions are listed under the TIME INTERVALS that they should be performed.

The TIME INTERVAL is part of the page number and code number.

Example: 8H 002-0; 8H is the TIME INTERVAL (8 operating hours), 002 is the PAGE NUMBER, and -0 is a CODE NUMBER that you as a customer should disregard. The dash number or code number is for the benefit of the publisher only.

The INDEX is set up under the TIME INTERVALS that the Lubrication and Preventive Maintenance should be performed.

| | | | |
|--------------------|----------------------------|---|-----------------------|
| Example: (8 Hours) | Time Interval (H=Hours) | & | Page Number (000-) |
| | 8H | | 503 |
| | 8H | | 373 |

The above states to check the sump tank fluid level every 8 operating hours and refer to page 503 for fluid recommendations etc. Also, to check brake pedal free travel at this interval and turn to page 373 for instructions.

Turn to the eight (8) hour section (8H) and then to the page listed — 503 or 373 etc. The instructions covered therein will pertain only to the checks or adjustments that should be performed at this TIME INTERVAL.

If, for instance, the Brake Pedal Free Travel is incorrect, you would then refer to the INDEX for "Brake Pedal Free Travel, adjust" which would be listed in the TIME INTERVALS following the 8 hour section.

| | | | |
|-----------------------------|----------------------------|---|-----------------------|
| <u>Example:</u> (100 Hours) | Time Interval (H=Hours) | & | Page Number (000-) |
| | 100H | | 302 |

Turn to the one hundred hour section (100H) and then to



INDUSTRIAL TRUCK DIVISION



(continued)

I N S T R U C T I O N S O N U S E O F M A N U A L

page 302. Complete instructions as to the importance of pedal free travel, the method to check and adjust for correct free travel with illustrations are included therein.

N O T E

YOU WILL NOTE THAT AT THE BEGINNING OF EVERY SECTION A LUBRICATION AND PREVENTIVE MAINTENANCE ILLUSTRATION IS SHOWN GIVING THE LOCATION OF THE COMPONENTS TO BE SERVICED.

It is impossible to cover all types of machine operations in one manual. Operating conditions should determine the lubrication and maintenance intervals. Common sense and a close observance can best determine the frequency with which you should service your machine.

The care you give your machine will greatly determine the satisfaction and service life that you will obtain from it. A definite maintenance program should be set up and followed. Haphazard maintenance will only lead to faulty performance and short life.



INDUSTRIAL TRUCK DIVISION



TABLE OF CONTENTS

| <u>Page</u> | <u>Description</u> |
|-------------|-------------------------------|
| A001 | Instructions On Use Of Manual |
| A002 | Instructions On Use Of Manual |
| A073 | Table Of Contents |
| A074 | Table Of Contents |
| B071 | Illustration Of Machine |
| B073 | Specifications |
| B074 | Specifications |
| B075 | NS-20 Specifications |
| B076 | NS-30-40 Specifications |
| B077 | NSP-20 Specifications |
| B078 | NSP-30 Specifications |
| B079 | NSP-40 Specifications |

OPERATIONS

| | |
|------|--|
| C070 | Overall Controls |
| C071 | Battery Connector Power Key Switch Combination Drive and Lift-Lower Control Handle |
| C073 | Battery Charge Indicator, Hour Meter |
| C173 | Brake and Parking Brake |
| C303 | To pick-up, move and deposit a load. Safety and Operating Suggestions |
| C304 | To pick-up, move and deposit a load. Safety and Operating Suggestions |

LUBRICATION AND PREVENTIVE MAINTENANCE

| <u>Time Interval (H-Hours)</u> | <u>& Page Number (0000-)</u> | <u>Description</u> |
|--|--|---|
| H | 071 | Index |
| H | 072 | Index |
| 8H | 000 | <u>8 Hour Lubrication & Preventive Maintenance Illustration</u> |
| 8H | 273 | Battery Charge Indicator, Hour Meter |
| 8H | 375 | Brake (Deadman) Switch check |
| 8H | 473 | Battery, Service Checks and Maintenance |
| 8H | 474 | Battery, Service Checks and Maintenance |
| 8H | 475 | Battery, Service Checks and Maintenance |
| 8H | 476 | Battery, Service Checks and Maintenance |
| 8H | 477 | Battery, Service Checks and Maintenance |
| 8H | 479 | Battery Removal and Installation |
| 8H | 503 | Hydraulic Sump Tank, level check |
| 100H | 000 | <u>100 Hour Lubrication & Preventive Maintenance Illustration</u> |
| 100H | 073 | Drive Unit, lubricant level check |
| 100H | 173 | Accelerator Master (Switch) Box and Drive Control Handle Linkage, check |
| 100H | 174 | Accelerator Master (Switch) Box and Drive Control Handle Linkage, check |
| 100H | 175 | Directional Switch, check and adjust |
| 100H | 176 | Switch Box I M.S. Switch and Directional Switch, adjust & checks |
| 100H | 177 | Accelerator Master Control (Switch) Box illustration -- exploded view |
| 100H | 178 | Adjustment of Travel Control, Plugging Control, Time Delays (Switch Box) Operating Sequence |
| 100H | 179 | Switch Box Maintenance; Switch Box Trouble Shooting |
| 100H | 180 | Accelerating Master Control (Switch Box) Operating Sequence |
| 100H | 181 | Drive Control Adjustment (upper portion) -- illustration |
| 100H | 182 | Drive Control Adjustment (lower portion), Combination Drive and Brake Control Rod, adjust; Deadman Rod, adjust |
| 100H | 183 | Off-Set Arm, adjust |



INDUSTRIAL TRUCK DIVISION



TABLE OF CONTENTS

LUBRICATION AND PREVENTIVE MAINTENANCE

| <u>Time Interval & (H-Hours)</u> | <u>Page Number (0000-)</u> | <u>Description</u> |
|--------------------------------------|----------------------------|--|
| 100H | 184 | Deadman Rod Adjustment -- illustration |
| 100H | 302 | Brake (Deadman) Pedal, and Brake Cylinder, Pivot Arm and Pedal Rod, check and adjust |
| 100H | 303 | Brake (Deadman) Pedal, and Brake Cylinder, Pivot Arm and Pedal Rod, check and adjust |
| 100H | 306 | Service-Parking Brake, check and adjust |
| 100H | 307 | Service-Parking Brake, check and adjust |
| 100H | 403 | Lift, Reach and Tilt Cylinder, operation checks; Lift Chain, check and adjust; Lubricate machine; Hydraulic Control Valve and Lines, inspect; Lift Carriage (Pantograph), inspect. |
| 100H | 473 | Lift and Tilt Switches, check |
| 100H | 503 | Hydraulic Sump (Breather) Filter, check |
| 100H | 673 | Contactors, inspect |
| 100H | 772 | Lubrication Chart |
| 100H | 773 | Lubrication Key and Instructions |
| 100H | 774 | Lubrication |
| 500H | 000 | <u>500 Hour Lubrication & Preventive Maintenance Illustration</u> |
| 500H | 173 | Drain Sump Tank, change filter; Check breather and replace if necessary. |
| 500H | 174 | Drain Sump Tank, change filter; Check breather and replace if necessary. |
| 500H | 473 | Caster Adjustment |
| 1000H | 000 | <u>1000 Hour Lubrication & Preventive Maintenance Illustration</u> |
| 1000H | 673 | Drive Motor, inspect |
| 1000H | 674 | Drive Motor Brush Spring Tension, check |
| 1000H | 773 | Pump Drive Motor, inspect |
| 1000H | 774 | Pump Drive Motor Brush Spring Tension, check |
| 1000H | 912 | Brake Bleeding Procedure |
| 1000H | 913 | Brake Bleeding Procedure |
| 1000H | 1307 | Drain Unit, drain & refill |
| 1000H | 1507 | Hydraulic System Pressure Checks (at valve) |
| 1000H | 1573 | Hydraulic System Checks (flow and pressure at pump) |
| 1000H | 1803 | Upright Roller, adjustment checks |
| 1000H | 1806 | Upright Rollers, check and adjust |
| 1000H | 1807 | Upright Rollers, check and adjust |
| 1000H | 1808 | Upright Rollers, check and adjust |
| 1000H | 1811 | Lift Carriage (Pantograph) Rollers, check and adjust |
| 1000H | 1815 | Roller Lubrication |

TROUBLE SHOOTING GUIDE

| <u>Page</u> | <u>Description</u> |
|-------------|---------------------------|
| 100H 179 | Switch Box |
| H003 | Hydraulic Circuit Diagram |
| H005 | Hydraulic Circuit Diagram |
| W001 | Wiring Diagram |



INDUSTRIAL TRUCK DIVISION



SPECIFICATIONS

POWER SUPPLY

Type battery Lead Acid
 Voltage 24
 Ampere Hour Capacity 500
 Battery Weight 1260 lbs.

CONTACTORS

Replacement: when approximately 1/16" wear is reached.

N.O. contact gap will be 5/16" ± 1/32"
 N.C. contact gap will be 1/4" ± 1/32"

Battery Compartment Size
 32 3/4 W x 12 1/8 L x 31 1/2 H

Optional Sizes: 37 x 12 1/8 x 31 1/2
 32 3/4 x 16 5/8 x 31 1/2
 37 x 16 5/8 x 31 1/2

TIRES (in inches)

Front Load OPTIONAL
 (Polyurethane) (Polyurethane)
 (Tandem) 4 Dia. x 2 5/8; (Tandem), 5 x 2 2/8

Front Load OPTIONAL
 (Rubber)
 (Single), 10 x 5

Rear Steer-Drive Rubber
 (Single), 10 1/2 x 6 x 5

Caster Polyurethane
 (Dual) 6 x 2

DIMENSIONS

Without forks 66 3/8'

Width

Height with upright lowered (128" MFH
 Standard Upright) 83

Basic aisle for right angle stacking...
 71" + 6" operating clearance

Free lift (in inches)

Standard upright 17 1/4
 Hilo upright 46 3/4
 Triple stage 13

Overall height with 128 MFH Std. Upr.
 164 1/4 inches

Overall width
 34 rear front varies 34 to 58 inches

Ground clearance - under Straddle Arms.....
 2 inches

Grade clearance 15.6%

HYDRAULIC SYSTEM

Suction Filter (cleanable)..100 Mesh Screen

Return line filter (replaceable)..10 micron

Sump tank breather (replaceable).. 5 micron

Sump tank capacity 6.5 gallons

HYDRAULIC VALVE

Pressure relief valve setting...1750 P.S.I.

BRAKE SYSTEM

Type Spring applied, Hydraulic release

Service-Parking Brake Effectiveness.....
 Refer to page 100H 912

SPEEDS AND GRADES

| | |
|--------------|--------|
| Forward | M.P.H. |
| Loaded | 4.9 |
| Empty | 5.5 |

| | |
|--------------|-----|
| Reverse | |
| Loaded | 4.9 |
| Empty | 5.5 |

| | |
|----------------------|-----|
| Gradeability | |
| With Rated Load..... | 10% |
| Empty | 10% |

| | |
|---------------|--------|
| Lifting Speed | |
| Loaded | 33 FPM |
| Empty | 50 FPM |

| | |
|----------------|--------|
| Lowering Speed | |
| Loaded | 60 FPM |
| Empty | 80 FPM |



INDUSTRIAL TRUCK DIVISION



S P E C I F I C A T I O N S

- BATTERY CONNECTOR.....SB-2
- HYDRAULIC PUMPS.....See page 1000H 1573
- BRUSH SPRING TENSION.....See page 1000H 774

**ENGINEERING
SPECIFICATIONS**

CLARKLIFT® NST 15

1,500 pounds capacity, 24 inch load center

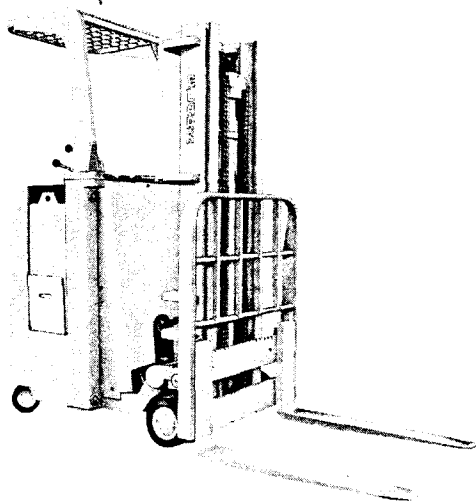

MODEL: NST 15

WEIGHT: With battery and 71"/106" standard upright — 4508 lbs. Includes 1220 lb. battery.

TIRES: Drive tire non-direction rubber — 10½" x 6" x 5"
Load wheels rubber 10" x 7" x 6¼"
Caster, dual, urethane — 6" x 2"

| SPEEDS: | Empty | 1500 lb. Load |
|-----------------------|----------------------|----------------------|
| Travel Speeds | 5.9 MPH (519 FPM) | 5.4 MPH (475 FPM) |
| Lift Speeds | 93 FPM | 60 FPM |
| Lower Speeds | 45 FPM | 31 FPM |
| Grade Clearance — 49% | | |

BATTERY POWER SUPPLY: 24 volt battery is standard. A selection of various KWH capacities are available to suit operation.

STANDARD BATTERY COMP: 12⅞" L x 32¾" W x 31½" H

OPTIONAL BATTERY COMP: 12⅞" L x 37" W x 31½" H
16⅞" L x 32¾" W x 31½" H*
16⅞" L x 37" W x 31½" H*

DIMENSIONS:

| | |
|---|--------------------|
| *Length to front of forks | 51½" |
| *Wheelbase | 34¾" |
| *Turning Radius | 44½" |
| Basic aisle for right angle stack | 52½" + load length |
| Underclearances | 4¼" |

*Increases 4½" with 16⅞" Long Battery Compartment

BATTERY CONNECTORS: Anderson type SB, standard. Easily accessible for quick disconnect. Both halves identical and interchangeable — one half mounted on truck, other half attached to flexible battery lead.

MOTORS: Pump and drive motors are fan cooled and ventilated; series-parallel windings in motor fields. Large contact-area brushes provide good commutation and long service life. Class "F" insulation protects motor windings against temperatures far in excess of those normal to motor, withstands mechanical abuse, are easily cleaned and resist most cleaning solvents.

CONTROLS: Two levers control:

1. Four speeds forward and reverse; also raises and lowers forks.
 2. Upright tilt; 10° back and 3° forward is standard.
- Lever is directional in operation and return to neutral when released.

BRAKES: Five-inch diameter, 1½" wide brake drum mounted on drive motor shaft, with brake multiplication through drive gear reduction. Radial fins on brake drum serve as fan to cool both brake drum and motor. Bonded linings eliminate rivet scoring.

STEERING: Chain reduction and anti-friction 6" radius hand wheel. Drive wheel position indicators standard.

UPRIGHT: Nested telescopic roller type. "I" beam inner section is nested within outer channel for greater safety and visibility. Side loading on upright rails is taken on upright rollers. Upright and carriage rollers are laterally adjustable for wear to maintain new truck tolerances. Carriage has additional lateral thrust rollers to prevent upright spread, insuring maximum free-rolling movement.

LIFT AND TILT CYLINDERS: Tilt rod chrome plated. Tilt lock insures positive control — no tilt drift. Both lift and tilt cylinders have metal rod wipers to keep foreign material from wearing packings. Free-floating mounting of lift cylinder minimizes side strains. Modulating flow regulator in cylinder base reduces maximum lowering speed as weight of load increases.

HYDRAULIC SYSTEM: Tandem hydraulic pumps permit increased lift speeds and precise tilt control. Full feathering balanced spool type valves for accurate load positioning. Built-in pressure relief valve protects system against overloads. Hydraulic sump built into frame of ⅝" thick plate has 6.5 gal. capacity. Flexible rubber hydraulic hose lines are steel braid reinforced. System is protected from dirt by (1) a sump air breather filter, (2) a 25-micron full flow filter in hydraulic line, (3) bronze cylinder rod wiper rings, (4) 100 mesh filter screen.

FORK CARRIAGE AND FORKS: Steel fork carriage of all-welded construction to withstand impacts. Lateral fork adjustments from 8" to 30" with standard load back rest. Convenient snap-action latch assures positive fork positioning. Heat treated and upset forged forks to provide full section strength at heel.

GENERAL: Ignition key lock to prevent unauthorized operation, electric horn, cushion floor mats and cushion compartment body pads; steering knob, all standard equipment. All exposed surfaces shot blasted and prime painted with weather-resistant paint. Driver's overhead guard and 48" high load back rest are standard. Standard color: yellow.

DIMENSIONAL SPECIFICATIONS

CLARKLIFT® NST 15

1,500 pounds capacity, 24 inch load center

CAPACITY CHART

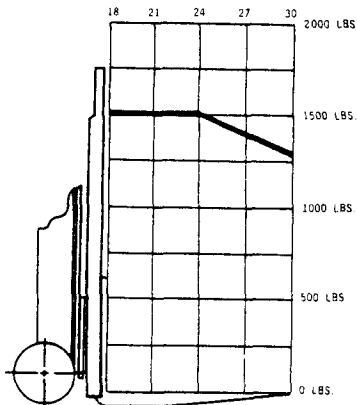

CAPACITY RATING BASED ON MINIMUM BATTERY WEIGHT OF 1220 POUNDS WITH UPRIGHT IN VERTICAL POSITION

UPRIGHT DIMENSION TABLE

| MFH | | DAHL | FREE LIFT | | | O.A.H. RAISED WITH 48" LBR | |
|-----|-------|------|-----------|------|------|----------------------------|---------|
| STD | HI-LO | | STD | FFL | TSU | STD-HI-LO | TSU-FFL |
| 64 | --- | 50 | 18 | --- | --- | 112 1/2 | --- |
| 70 | --- | 53 | 18 | --- | --- | 118 3/4 | --- |
| 76 | --- | 56 | 18 | --- | --- | 124 1/2 | --- |
| 82 | --- | 59 | 18 | --- | --- | 130 3/4 | --- |
| 94 | --- | 62 | 18 | --- | --- | 136 1/2 | --- |
| 94 | 94 | 65 | 18 | 45** | 12-2 | 142 1/2 | 183 |
| 100 | 100 | 68 | 18 | 48* | 12-2 | 148 1/2 | 192 |
| 106 | 106 | 71 | 18 | 51** | 12-2 | 154 1/2 | 201 |
| 112 | 112 | 74 | 18 | 54* | 12-2 | 160 1/2 | 210 |
| 118 | 118 | 77 | 18 | 57** | 12-2 | 166 1/2 | 219 |
| 124 | 124 | 80 | 18 | 60** | 12-2 | 172 1/2 | 228 |
| 130 | 130 | 83 | 18 | 63** | 12-2 | 178 1/2 | 237 |

INTERMEDIATE HEIGHTS AVAILABLE IN INCREMENTS OF 3" MFH. FOR FORK HEIGHTS ABOVE 154" MFH CONTACT FACTORY FOR CAPACITY

* INDICATES PREFERRED STANDARD SIZES.
** SUBTRACT 28" FOR LOAD BACK REST.



On all CLARK literature, dimensional and performance specifications are checked for accuracy by the engineering department.

NOTE: Clark products and specifications are subject to improvements and changes without notice.

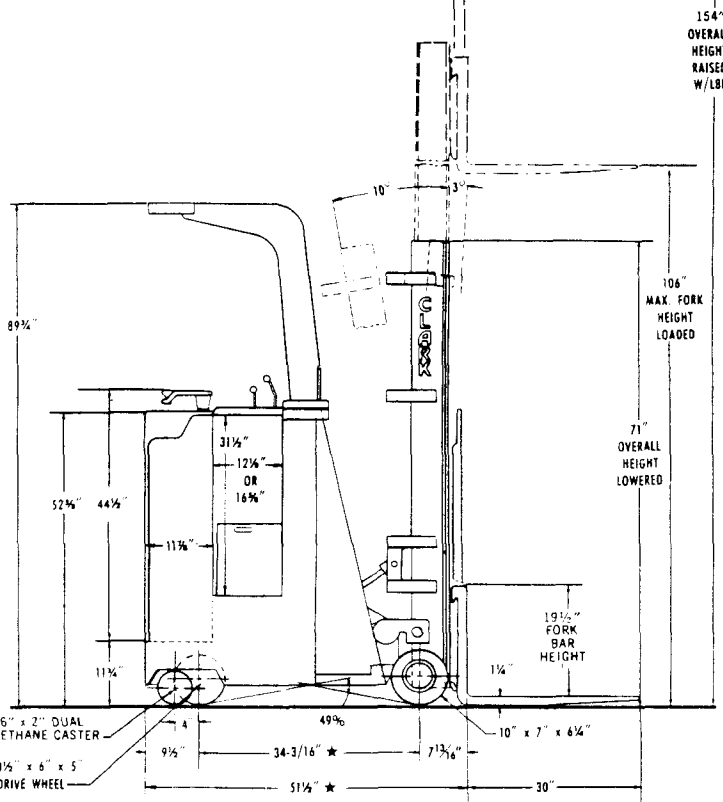
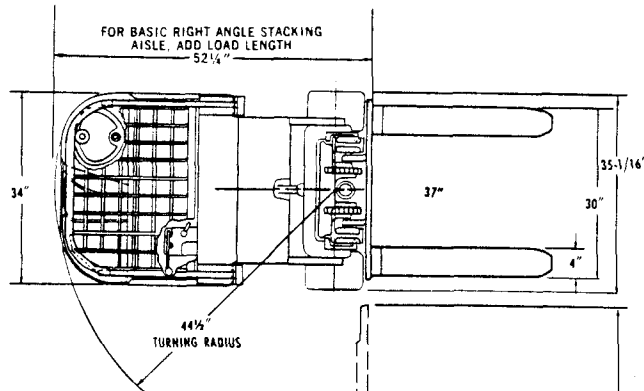

★ WITH 12 1/2" BATTERY COMPARTMENT
ADD 4 1/2" FOR 16 1/2" BATTERY COMPARTMENT

**ENGINEERING
SPECIFICATIONS**

CLARKLIFT® NST 20

2,000 pounds capacity, 24 inch load center

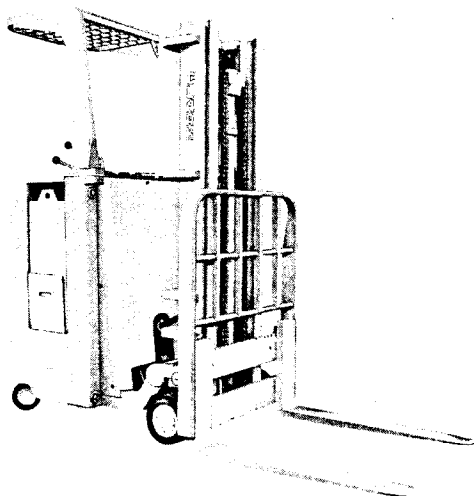

MODEL: NST 20

WEIGHT: With battery and 71"/106" standard upright — 5131 lbs. Includes 1220 lb. battery.

TIRES: Drive tire non-direction rubber — 10½" x 6" x 5"
Load wheels rubber 10" x 7" x 6¼"
Caster, dual, urethane — 6" x 2"

| SPEEDS: | Empty | 2000 lb. Load |
|---------------------|----------------------|----------------------|
| Travel Speeds | 5.7 MPH (501 FPM) | 4.9 MPH (431 FPM) |
| Lift Speeds | 93 FPM | 54 FPM |
| Lower Speeds | 43 FPM | 23 FPM |
| Grade Clearance — | 49% | |

BATTERY POWER SUPPLY: 24 volt battery is standard. A selection of various KWH capacities are available to suit operation.

STANDARD BATTERY COMP: 12¼" L x 32¾" W x 31½" H

OPTIONAL BATTERY COMP: 12¼" L x 37" W x 31½" H
16⅝" L x 32¾" W x 31½" H*
16⅝" L x 37" W x 31½" H*

DIMENSIONS:

| | |
|---|--------------------|
| *Length to front of forks | 51½" |
| *Wheelbase | 34¾" |
| *Turning Radius | 44½" |
| Basic aisle for right angle stack..... | 52½" + load length |
| Underclearances | 4¼" |
| *Increases 4½" with 16⅝" Long Battery Compartment | |

BATTERY CONNECTORS: Anderson type SB, standard. Easily accessible for quick disconnect. Both halves identical and interchangeable — one half mounted on truck, other half attached to flexible battery lead.

MOTORS: Pump and drive motors are fan cooled and ventilated; series-parallel windings in motor fields. Large contact-area brushes provide good commutation and long service life. Class "F" insulation protects motor windings against temperatures far in excess of those normal to motor, withstands mechanical abuse, are easily cleaned and resist most cleaning solvents.

CONTROLS: Two levers control:

1. Four speeds forward and reverse; also raises and lowers forks.
2. Upright tilt; 10° back and 3° forward is standard. Levers are directional in operation and return to neutral when released.

BRAKES: Five-inch diameter, 1½" wide brake drum mounted on drive motor shaft, with brake multiplication through drive gear reduction. Radial fins on brake drum serve as fan to cool both brake drum and motor. Bonded linings eliminate rivet scoring.

STEERING: Chain reduction and anti-friction 6" radius hand wheel. Drive wheel position indicators standard.

UPRIGHT: Nested telescopic roller type. "I" beam inner section is nested within outer channel for greater safety and visibility. Side loading on upright rails is taken on upright rollers. Upright and carriage rollers are laterally adjustable for wear to maintain new truck tolerances. Carriage has additional lateral thrust rollers to prevent upright spread, insuring maximum free-rolling movement.

LIFT AND TILT CYLINDERS: Tilt rod chrome plated. Tilt lock insures positive control — no tilt drift. Both lift and tilt cylinders have metal rod wipers to keep foreign material from wearing packings. Free-floating mounting of lift cylinder minimizes side strains. Modulating flow regulator in cylinder base reduces maximum lowering speed as weight of load increases.

HYDRAULIC SYSTEM: Tandem hydraulic pumps permit increased lift speeds and precise tilt control. Full feathering balanced spool type valves for accurate load positioning. Built-in pressure relief valve protects system against overloads. Hydraulic sump built into frame of ⅜" thick plate has 6.5 gal. capacity. Flexible rubber hydraulic hose lines are steel braid reinforced. System is protected from dirt by (1) a sump air breather filter, (2) a 25-micron full flow filter in hydraulic line, (3) bronze cylinder rod wiper rings, (4) 100 mesh filter screen.

FORK CARRIAGE AND FORKS: Steel fork carriage of all-welded construction to withstand impacts. Lateral fork adjustments from 8" to 30" with standard load back rest. Convenient snap-action latch assures positive fork positioning. Heat treated and upset forged forks to provide full section strength at heel.

GENERAL: Ignition key lock to prevent unauthorized operation, electric horn, cushion floor mats and cushion compartment body pads; steering knob, all standard equipment. All exposed surfaces shot blasted and prime painted with weather-resistant paint. Driver's overhead guard and 48" high load back rest are standard. Standard color: yellow.

**DIMENSIONAL
SPECIFICATIONS**

CLARKLIFT® NST 20

2,000 pounds capacity, 24 inch load center

CAPACITY CHART

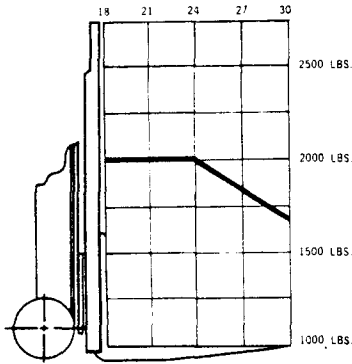

CAPACITY RATING BASED ON MINIMUM BATTERY WEIGHT OF 1220 POUNDS WITH UPRIGHT IN VERTICAL POSITION.

UPRIGHT DIMENSION TABLE

| MFH | | OAH | | FREE LIFT | | | O.A.H. RAISED WITH 48" LBR | |
|------|------|-----|---------|-----------|------|--------|----------------------------|---------|
| STD | M-LO | TSU | FFL-TSU | STD | M-LO | TSU | STD-M-LO | TSU-FFL |
| 64 | --- | --- | 50 | 18 | --- | --- | 112 1/2 | --- |
| 70 | --- | --- | 53 | 18 | --- | --- | 118 1/2 | --- |
| 76 | --- | --- | 56 | 18 | --- | --- | 124 1/2 | --- |
| 82 | --- | --- | 59 | 18 | --- | --- | 130 1/2 | --- |
| 88 | --- | --- | 62 | 18 | --- | --- | 136 1/2 | --- |
| 94 | 94 | 135 | 65 | 18 | 45** | 12 1/2 | 142 1/2 | 183 |
| 100 | 100 | 144 | 68 | 18 | 48** | 12 1/2 | 148 1/2 | 192 |
| *106 | 106 | 153 | 71 | 18 | 51** | 12 1/2 | 154 1/2 | 201 |
| 112 | 112 | 162 | 74 | 18 | 54** | 12 1/2 | 160 1/2 | 210 |
| 118 | 118 | 171 | 77 | 18 | 57** | 12 1/2 | 166 1/2 | 219 |
| *124 | 124 | 180 | 80 | 18 | 60** | 12 1/2 | 172 1/2 | 228 |
| *130 | 130 | 189 | 83 | 18 | 63** | 12 1/2 | 178 1/2 | 237 |

INTERMEDIATE HEIGHTS AVAILABLE IN INCREMENTS OF 3" MFH FOR FORK HEIGHTS ABOVE 154" MFH CONTACT FACTORY FOR CAPACITY.

* INDICATES PREFERRED STANDARD SIZES.
** SUBTRACT 28" FOR LOAD BACK REST.



On all CLARK literature, dimensional and performance specifications are checked for accuracy by the engineering department.

NOTE: Clark products and specifications are subject to improvements and changes without notice.

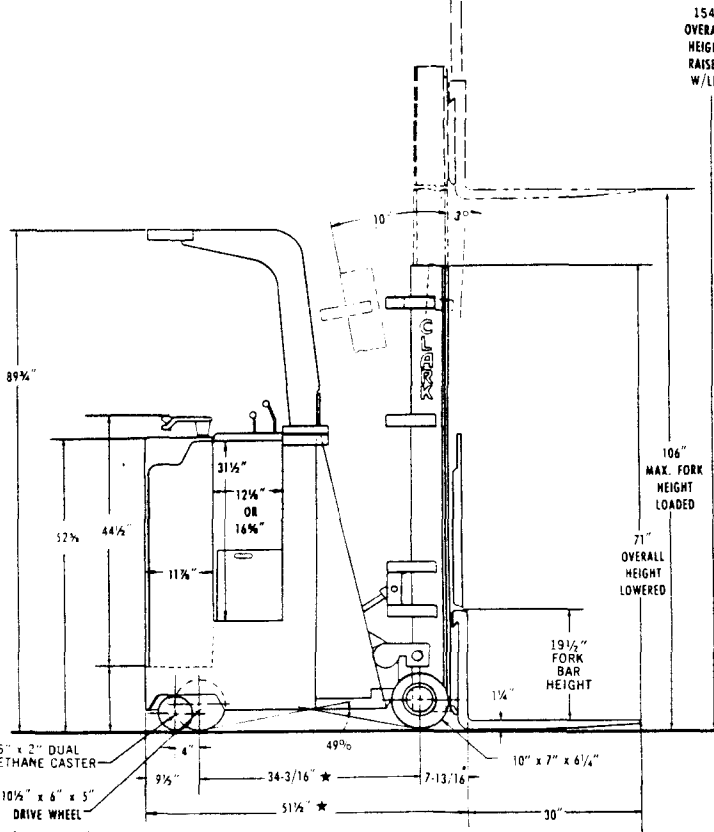
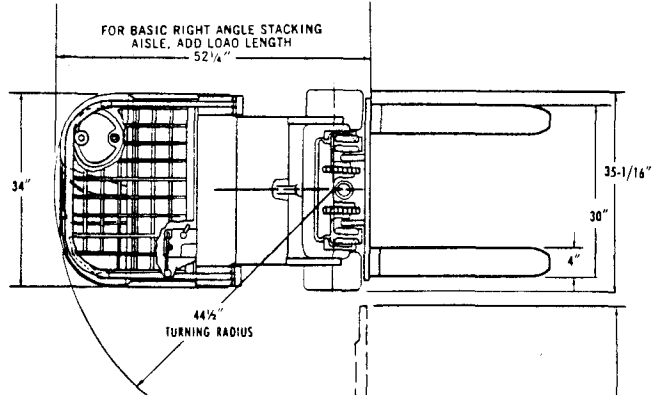

* WITH 12 1/2" BATTERY COMPARTMENT
ADD 4 1/2" FOR 16 1/2" BATTERY COMPARTMENT

**ENGINEERING
SPECIFICATIONS**

CLARKLIFT® NST 25

2,500 pounds capacity, 24 inch load center

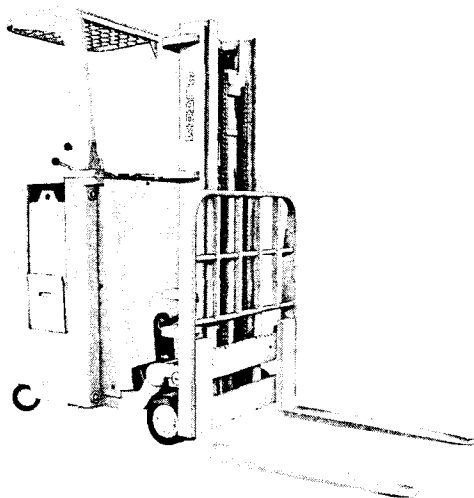

MODEL: NST 25

WEIGHT: With battery and 71" 106" standard upright — 5505 lbs. Includes 1220 lb. battery.

TIRES: Drive tire non-direction rubber — 10½" x 6" x 5"
Load wheels rubber 10" x 7" x 6¼"
Caster, dual, urethane — 6" x 2"

| SPEEDS: | Empty | 2500 lb. Load |
|-----------------------|----------------------|----------------------|
| Travel Speeds | 5.5 MPH (484 FPM) | 4.6 MPH (404 FPM) |
| Lift Speeds | 93 FPM | 45 FPM |
| Lower Speeds | 44 FPM | 22 FPM |
| Grade Clearance — 49% | | |

BATTERY POWER SUPPLY: 24 volt battery is standard. A selection of various KWH capacities are available to suit operation.

STANDARD BATTERY COMP: 12¼" L x 32¾" W x 31½" H

OPTIONAL BATTERY COMP: 12¼" L x 37" W x 31½" H
16⅝" L x 32¾" W x 31½" H*
16⅝" L x 37" W x 31½" H*

DIMENSIONS:

- *Length to front of forks 51½"
- *Wheelbase 34⅜"
- *Turning Radius 44½"
- Basic aisle for right angle stack ... 52½" + load length
- Underclearances 4¼"
- *Increases 4½" with 16⅝" Long Battery Compartment

BATTERY CONNECTORS: Anderson type SB, standard. Easily accessible for quick disconnect. Both halves identical and interchangeable — one half mounted on truck, other half attached to flexible battery lead.

MOTORS: Pump and drive motors are fan cooled and ventilated; series-parallel windings in motor fields. Large contact-area brushes provide good commutation and long service life. Class "F" insulation protects motor windings against temperatures far in excess of those normal to motor, withstands mechanical abuse, are easily cleaned and resist most cleaning solvents.

CONTROLS: Two levers control:

1. Four speeds forward and reverse; also raises and lowers forks.
 2. Upright tilt; 10° back and 3° forward is standard.
- Levers are directional in operation and return to neutral when released.

BRAKES: Five-inch diameter, 1½" wide brake drum mounted on drive motor shaft, with brake multiplication through drive gear reduction. Radial fins on brake drum serve as fan to cool both brake drum and motor. Bonded linings eliminate rivet scoring.

STEERING: Chain reduction and anti-friction 6" radius hand wheel. Drive wheel position indicators standard.

UPRIGHT: Nested telescopic roller type. "I" beam inner section is nested within outer channel for greater safety and visibility. Side loading on upright rails is taken on upright rollers. Upright and carriage rollers are laterally adjustable for wear to maintain new truck tolerances. Carriage has additional lateral thrust rollers to prevent upright spread, insuring maximum free-rolling movement.

LIFT AND TILT CYLINDERS: Tilt rod chrome plated. Tilt lock insures positive control — no tilt drift. Both lift and tilt cylinders have metal rod wipers to keep foreign material from wearing packings. Free-floating mounting of lift cylinder minimizes side strains. Modulating flow regulator in cylinder base reduces maximum lowering speed as weight of load increases.

HYDRAULIC SYSTEM: Tandem hydraulic pumps permit increased lift speeds and precise tilt control. Full feathering balanced spool type valves for accurate load positioning. Built-in pressure relief valve protects system against overloads. Hydraulic sump built into frame of ⅜" thick plate has 6.5 gal. capacity. Flexible rubber hydraulic hose lines are steel braid reinforced. System is protected from dirt by (1) a sump air breather filter, (2) a 25-micron full flow filter in hydraulic line, (3) bronze cylinder rod wiper rings, (4) 100 mesh filter screen.

FORK CARRIAGE AND FORKS: Steel fork carriage of all-welded construction to withstand impacts. Lateral fork adjustments from 8" to 30" with standard load back rest. Convenient snap-action latch assures positive fork positioning. Heat treated and upset forged forks to provide full section strength at heel.

GENERAL: Ignition key lock to prevent unauthorized operation, electric horn, cushion floor mats and cushion compartment body pads; steering knob, all standard equipment. All exposed surfaces shot blasted and prime painted with weather-resistant paint. Driver's overhead guard and 48" high load back rest are standard. Standard color: yellow.

DIMENSIONAL SPECIFICATIONS

CLARKLIFT® NST 25

2,500 pounds capacity, 24 inch load center

CAPACITY CHART

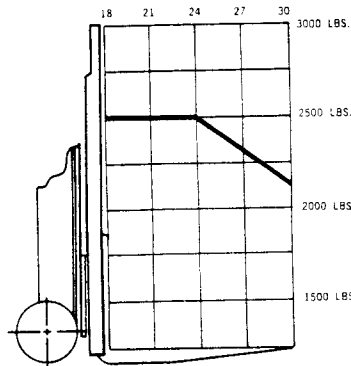

CAPACITY RATING BASED ON MINIMUM BATTERY WEIGHT OF 1270 POUNDS WITH UPRIGHT IN VERTICAL POSITION

UPRIGHT DIMENSION TABLE

| MFH | DASH | | FREE LIFT | | | O.A.M. RAISED WITH 48" LBR | |
|------|------|------|-----------|------|------|----------------------------|---------|
| | STD | M-LO | TSU FFL | M-LC | TSU | STD-M-LO | TSU FFL |
| 64 | --- | --- | 50 | 18 | --- | 112 1/2 | --- |
| 70 | --- | --- | 53 | 18 | --- | 118 1/2 | --- |
| 75 | --- | --- | 56 | 18 | --- | 124 1/2 | --- |
| 82 | --- | --- | 59 | 18 | --- | 130 1/2 | --- |
| 88 | --- | --- | 62 | 18 | --- | 136 1/2 | --- |
| 94 | 94 | 135 | 65 | 18 | 45** | 142 1/2 | 183 |
| 100 | 100 | 144 | 68 | 18 | 48** | 148 1/2 | 192 |
| *106 | 106 | 153 | 71 | 18 | 51** | 154 1/2 | 201 |
| 112 | 112 | 162 | 74 | 18 | 54** | 160 1/2 | 210 |
| 118 | 118 | 171 | 77 | 18 | 57** | 166 1/2 | 219 |
| 124 | 124 | 180 | 80 | 18 | 60** | 172 1/2 | 228 |
| *130 | 130 | 189 | 83 | 18 | 63** | 178 1/2 | 237 |

INTERMEDIATE HEIGHTS AVAILABLE IN INCREMENTS OF 3" MFH FOR FORK HEIGHTS ABOVE 154" MFH CONTACT FACTORY FOR CAPACITY.

* INDICATES PREFERRED STANDARD SIZES.
** SUBTRACT 28" FOR LOAD BACK REST.



On all CLARK literature, dimensional and performance specifications are checked for accuracy by the engineering department.

NOTE: Clark products and specifications are subject to improvements and changes without notice.

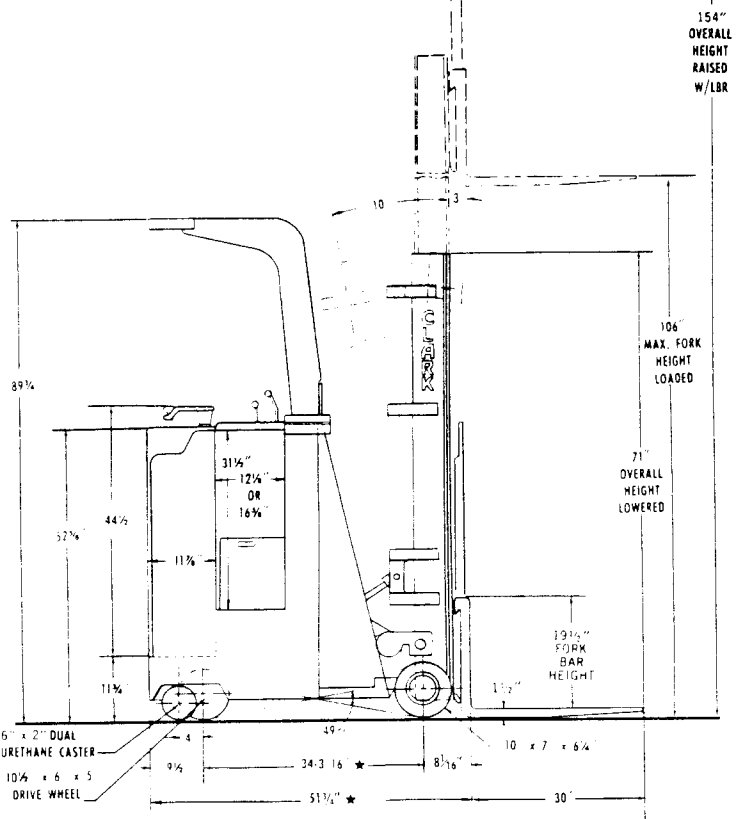
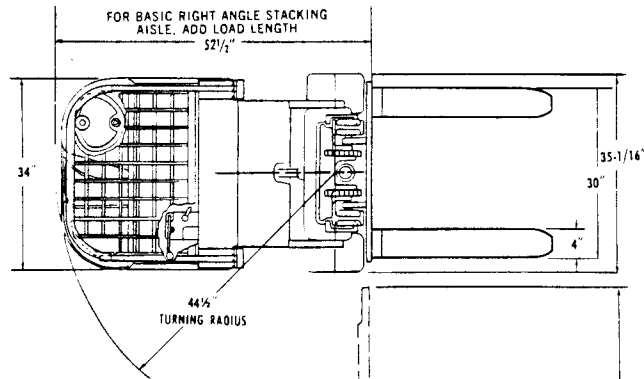

* WITH 12" BATTERY COMPARTMENT
ADD 4 1/2" FOR 16" BATTERY COMPARTMENT

**ENGINEERING
SPECIFICATIONS**

CLARKLIFT® NST 30

3,000 pounds capacity, 24 inch load center

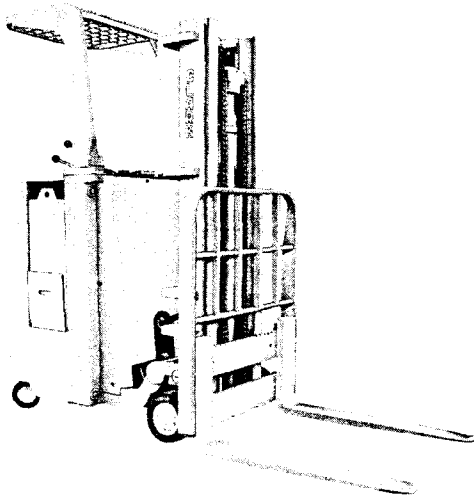

MODEL: NST 30

WEIGHT: With battery and 71" / 106" standard upright — 5847 lbs. Includes 1220 lb. battery.

TIRES: Drive tire non-direction rubber — 10½" x 6" x 5"
Load wheels urethane 10" x 5" x 6¼"
Caster, dual, urethane — 6" x 2"

| SPEEDS: | Empty | 3000 lb. Load |
|---------------------|----------------------|----------------------|
| Travel Speeds | 5.6 MPH (492 FPM) | 4.5 MPH (396 FPM) |
| Lift Speeds | 55 FPM | 35 FPM |
| Lower Speeds | 30 FPM | 16 FPM |
| Grade Clearance — | 41% | |

BATTERY POWER SUPPLY: 24 volt battery is standard. A selection of various KWH capacities are available to suit operation.

STANDARD BATTERY COMP: 12½" L x 32¾" W x 31½" H

OPTIONAL BATTERY COMP: 12½" L x 37" W x 31½" H
16⅝" L x 32¾" W x 31½" H*
16⅝" L x 37" W x 31½" H*

DIMENSIONS:

| | |
|--|--------------------|
| *Length to front of forks | 58½" |
| *Wheelbase | 40½" |
| *Turning Radius | 51" |
| Basic aisle for right angle stack: | 59½" + load length |
| Underclearances | 4¼" |

*Increases 4½" with 16⅝" Long Battery Compartment

BATTERY CONNECTORS: Anderson type SB, standard. Easily accessible for quick disconnect. Both halves identical and interchangeable — one half mounted on truck, other half attached to flexible battery lead.

MOTORS: Pump and drive motors are fan cooled and ventilated; series-parallel windings in motor fields. Large contact-area brushes provide good commutation and long service life. Class "F" insulation protects motor windings against temperatures far in excess of those normal to motor, withstands mechanical abuse, are easily cleaned and resist most cleaning solvents.

CONTROLS: Two levers control:

1. Four speeds forward and reverse; also raises and lowers forks.
 2. Upright tilt; 10° back and 3° forward is standard.
- Levers are directional in operation and return to neutral when released.

BRAKES: Five-inch diameter, 1½" wide brake drum mounted on drive motor shaft, with brake multiplication through drive gear reduction. Radial fins on brake drum serve as fan to cool both brake drum and motor. Bonded linings eliminate rivet scoring.

STEERING: Chain reduction and anti-friction 6" radius hand wheel. Drive wheel position indicators standard.

UPRIGHT: Nested telescopic roller type. "I" beam inner section is nested within outer channel for greater safety and visibility. Side loading on upright rails is taken on upright rollers. Upright and carriage rollers are laterally adjustable for wear to maintain new truck tolerances. Carriage has additional lateral thrust rollers to prevent upright spread, insuring maximum free-rolling movement.

LIFT AND TILT CYLINDERS: Tilt rod chrome plated. Tilt lock insures positive control — no tilt drift. Both lift and tilt cylinders have metal rod wipers to keep foreign material from wearing packings. Free-floating mounting of lift cylinder minimizes side strains. Modulating flow regulator in cylinder base reduces maximum lowering speed as weight of load increases.

HYDRAULIC SYSTEM: Tandem hydraulic pumps permit increased lift speeds and precise tilt control. Full feathering balanced spool type valves for accurate load positioning. Built-in pressure relief valve protects system against overloads. Hydraulic sump built into frame of ⅜" thick plate has 6.5 gal. capacity. Flexible rubber hydraulic hose lines are steel braid reinforced. System is protected from dirt by (1) a sump air breather filter, (2) a 25-micron full flow filter in hydraulic line, (3) bronze cylinder rod wiper rings, (4) 100 mesh filter screen.

FORK CARRIAGE AND FORKS: Steel fork carriage of all-welded construction to withstand impacts. Lateral fork adjustments from 10" to 36" with standard load back rest. Convenient snap-action latch assures positive fork positioning. Heat treated and upset forged forks to provide full section strength at heel.

GENERAL: Ignition key lock to prevent unauthorized operation, electric horn, cushion floor mats and cushion compartment body pads; steering knob, all standard equipment. All exposed surfaces shot blasted and prime painted with weather-resistant paint. Driver's overhead guard and 48" high load back rest are standard. Standard color: yellow.

DIMENSIONAL SPECIFICATIONS

CLARKLIFT® NST 30

3,000 pounds capacity, 24 inch load center

CAPACITY CHART

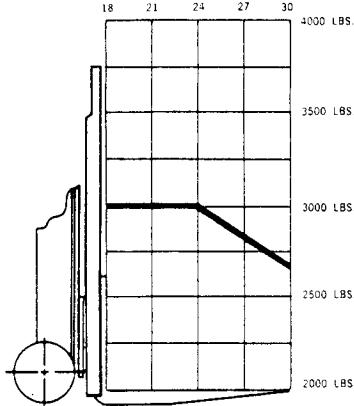

CAPACITY RATING BASED ON MINIMUM BATTERY WEIGHT OF 1220 POUNDS WITH UPRIGHT IN VERTICAL POSITION.

UPRIGHT DIMENSION TABLE

| MFH | | OAWL | FREE LIFT | | | D.A.M. RAISED WITH 48" LBR | |
|-----|-------|------|-----------|-------|-----|----------------------------|-------|
| STD | HI-LO | | TSU | HI-LO | TSU | STD | HI-LO |
| 64 | --- | 50 | 17 1/2 | --- | --- | 112 3/4 | --- |
| 70 | --- | 53 | 17 1/2 | --- | --- | 118 3/4 | --- |
| 76 | --- | 56 | 17 1/2 | --- | --- | 124 3/4 | --- |
| 82 | --- | 59 | 17 1/2 | --- | --- | 130 3/4 | --- |
| 88 | --- | 62 | 17 1/2 | --- | --- | 136 3/4 | --- |
| 94 | 33 | 65 | 17 1/2 | 45** | 13 | 142 3/4 | 183 |
| 100 | 100 | 68 | 17 1/2 | 48** | 13 | 148 3/4 | 192 |
| 106 | 106 | 71 | 17 1/2 | 51** | 13 | 154 3/4 | 201 |
| 112 | 112 | 74 | 17 1/2 | 54** | 13 | 160 3/4 | 210 |
| 118 | 118 | 77 | 17 1/2 | 57** | 13 | 166 3/4 | 219 |
| 124 | 124 | 80 | 17 1/2 | 60** | 13 | 172 3/4 | 228 |
| 130 | 130 | 83 | 17 1/2 | 63** | 13 | 178 3/4 | 237 |

INTERMEDIATE HEIGHTS AVAILABLE IN INCREMENTS OF 3" MFH - FOR FORK HEIGHTS ABOVE 154" MFH CONTACT FACTORY FOR CAPACITY.

* INDICATES PREFERRED STANDARD SIZES.
** SUBTRACT 28" FOR LOAD BACK REST.



On all CLARK literature, dimensional and performance specifications are checked for accuracy by the engineering department.

NOTE: Clark products and specifications are subject to improvements and changes without notice.

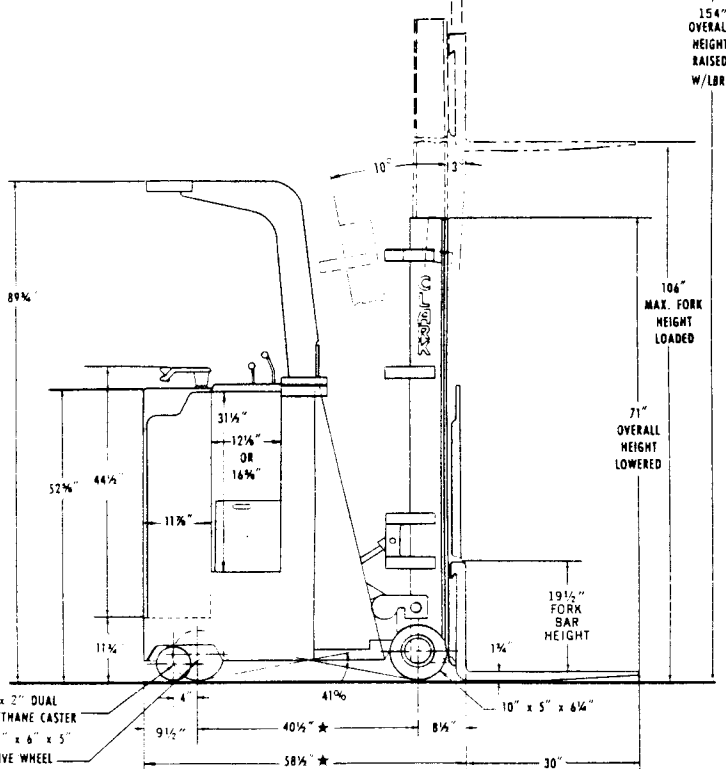
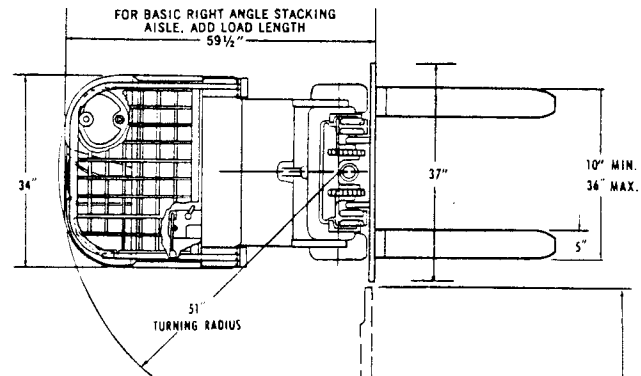

* WITH 12 1/2" BATTERY COMPARTMENT
ADD 4 1/2" FOR 16 1/2" BATTERY COMPARTMENT

ENGINEERING
SPECIFICATIONS

CLARKLIFT® NST 40

4,000 pounds capacity, 24 inch load center

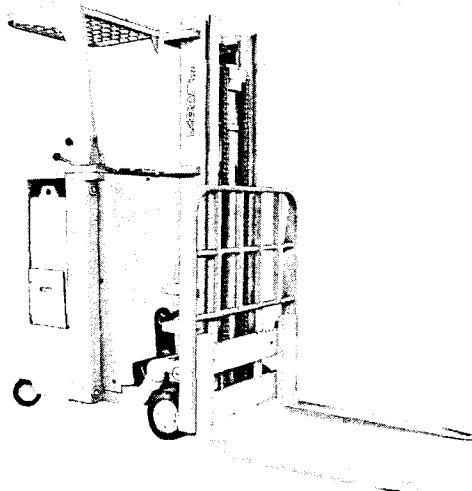

MODEL: NST 40

WEIGHT: With battery and 71" 106" standard upright — 5988 lbs. Includes 1220 lb. battery.

TIRES: Drive tire non-direction rubber — 10½" x 6" x 5"
Load wheels urethane 10" x 5" x 6¼"
Caster, dual, urethane — 6" x 2"

| SPEEDS: | Empty | 4000 lb. Load |
|-----------------------|----------------------|----------------------|
| Travel Speeds | 5.6 MPH (492 FPM) | 4.1 MPH (360 FPM) |
| Lift Speeds | 55 FPM | 31 FPM |
| Lower Speeds | 30 FPM | 16 FPM |
| Grade Clearance — 33% | | |

BATTERY POWER SUPPLY: 24 volt battery is standard. A selection of various KWH capacities are available to suit operation.

STANDARD BATTERY COMP: 12½" L x 32¾" W x 31½" H

OPTIONAL BATTERY COMP: 12½" L x 37" W x 31½" H
16⅝" L x 32¾" W x 31½" H*
16⅝" L x 37" W x 31½" H*

DIMENSIONS:

| | |
|--|--------------------|
| *Length to front of forks | 68½" |
| *Wheelbase | 50½" |
| *Turning Radius | 61" |
| Basic aisle for right angle stack..... | 69½" + load length |
| Underclearances | 4¼" |

*Increases 4½" with 16⅝" Long Battery Compartment

BATTERY CONNECTORS: Anderson type SB, standard. Easily accessible for quick disconnect. Both halves identical and interchangeable — one half mounted on truck, other half attached to flexible battery lead.

MOTORS: Pump and drive motors are fan cooled and ventilated; series-parallel windings in motor fields. Large contact-area brushes provide good commutation and long service life. Class "F" insulation protects motor windings against temperatures far in excess of those normal to motor, withstands mechanical abuse, are easily cleaned and resist most cleaning solvents.

CONTROLS: Two levers control:

1. Four speeds forward and reverse; also raises and lowers forks.
2. Upright tilt; 10° back and 3° forward is standard. Levers are directional in operation and return to neutral when released.

BRAKES: Five-inch diameter, 1½" wide brake drum mounted on drive motor shaft, with brake multiplication through drive gear reduction. Radial fins on brake drum serve as fan to cool both brake drum and motor. Bonded linings eliminate rivet scoring.

STEERING: Chain reduction and anti-friction 6" radius hand wheel. Drive wheel position indicators standard.

UPRIGHT: Nested telescopic roller type. "I" beam inner section is nested within outer channel for greater safety and visibility. Side loading on upright rails is taken on upright rollers. Upright and carriage rollers are laterally adjustable for wear to maintain new truck tolerances. Carriage has additional lateral thrust rollers to prevent upright spread, insuring maximum free-rolling movement.

LIFT AND TILT CYLINDERS: Tilt rod chrome plated. Tilt lock insures positive control — no tilt drift. Both lift and tilt cylinders have metal rod wipers to keep foreign material from wearing packings. Free-floating mounting of lift cylinder minimizes side strains. Modulating flow regulator in cylinder base reduces maximum lowering speed as weight of load increases.

HYDRAULIC SYSTEM: Tandem hydraulic pumps permit increased lift speeds and precise tilt control. Full feathering balanced spool type valves for accurate load positioning. Built-in pressure relief valve protects system against overloads. Hydraulic sump built into frame of ⅜" thick plate has 6.5 gal. capacity. Flexible rubber hydraulic hose lines are steel braid reinforced. System is protected from dirt by (1) a sump air breather filter, (2) a 25-micron full flow filter in hydraulic line, (3) bronze cylinder rod wiper rings, (4) 100 mesh filter screen.

FORK CARRIAGE AND FORKS: Steel fork carriage of all-welded construction to withstand impacts. Lateral fork adjustments from 10" to 36" with standard load back rest. Convenient snap-action latch assures positive fork positioning. Heat treated and upset forged forks to provide full section strength at heel.

GENERAL: Ignition key lock to prevent unauthorized operation, electric horn, cushion floor mats and cushion compartment body pads; steering knob, all standard equipment. All exposed surfaces shot blasted and prime painted with weather-resistant paint. Driver's overhead guard and 48" high load back rest are standard. Standard color: yellow.

**DIMENSIONAL
SPECIFICATIONS**

CLARKLIFT® NST 40

4,000 pounds capacity, 24 inch load center

CAPACITY CHART

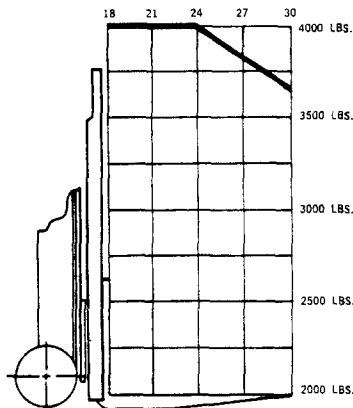

CAPACITY RATING BASED ON MINIMUM BATTERY WEIGHT OF 1220 POUNDS WITH UPRIGHT IN VERTICAL POSITION.

UPRIGHT DIMENSION TABLE

| MFH | | FREE LIFT | | | O.A.H. RAISED WITH 48" LBR | |
|------|-------|-------------|------|---------------|----------------------------|-------------------|
| STD | HI-LO | TSU FFL-TSU | OAML | HI-LO FFL-TSU | TSU | STD-HI-LO FFL-TSU |
| 64 | --- | --- | 50 | 17 1/2 | --- | 112 1/2 |
| 70 | --- | --- | 53 | 17 1/2 | --- | 118 1/2 |
| 76 | --- | --- | 56 | 17 1/2 | --- | 124 1/2 |
| 82 | --- | --- | 59 | 17 1/2 | --- | 130 1/2 |
| 88 | --- | --- | 62 | 17 1/2 | --- | 136 1/2 |
| 94 | 94 | 135 | 65 | 17 1/2 | 45** | 142 1/2 |
| 100 | 100 | 144 | 68 | 17 1/2 | 48** | 148 1/2 |
| *106 | 106 | 153 | 71 | 17 1/2 | 51** | 154 1/2 |
| 112 | 112 | 162 | 74 | 17 1/2 | 54** | 160 1/2 |
| 118 | 118 | 171 | 77 | 17 1/2 | 57** | 166 1/2 |
| 124 | 124 | 180 | 80 | 17 1/2 | 60** | 172 1/2 |
| *130 | 130 | 189 | 83 | 17 1/2 | 63** | 178 1/2 |

INTERMEDIATE HEIGHTS AVAILABLE IN INCREMENTS OF 3" MFH. FOR FORK HEIGHTS ABOVE 154" MFH CONTACT FACTORY FOR CAPACITY.

* INDICATES PREFERRED STANDARD SIZES.
** SUBTRACT 28" FOR LOAD BACK REST.



On all CLARK literature, dimensional and performance specifications are checked for accuracy by the engineering department.

NOTE: Clark products and specifications are subject to improvements and changes without notice.

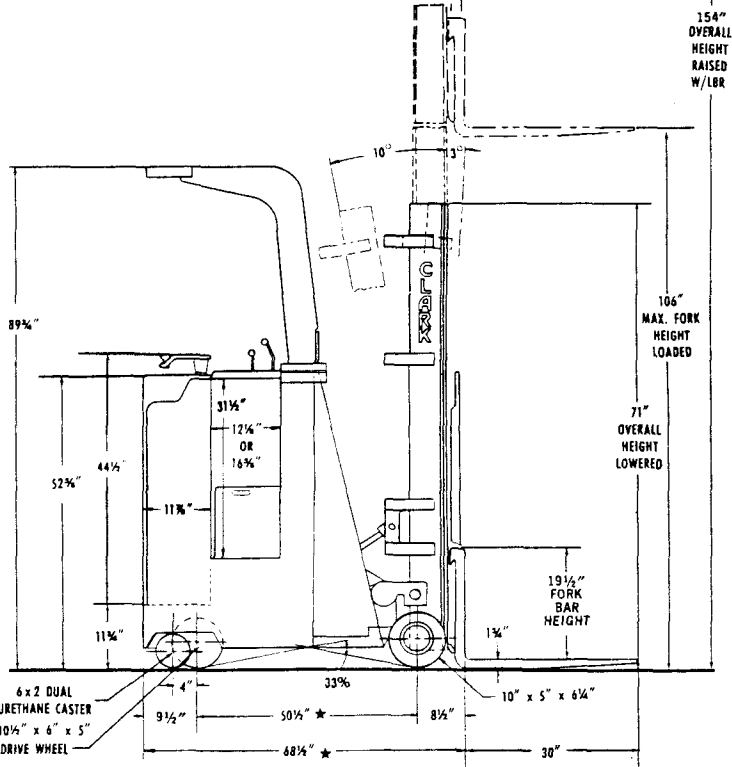
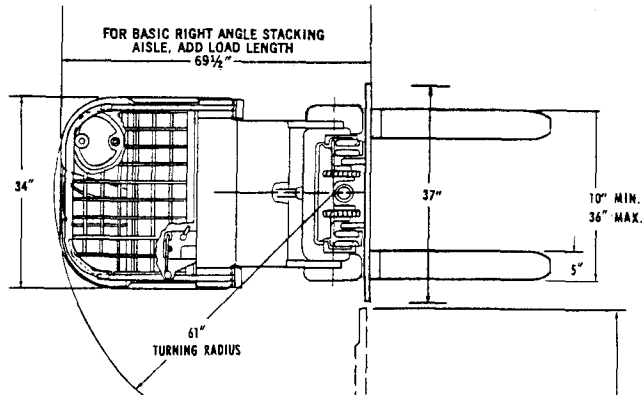

* WITH 12 1/2" BATTERY COMPARTMENT
ADD 4 1/2" FOR 16 1/2" BATTERY COMPARTMENT



INDUSTRIAL TRUCK DIVISION



NEW MACHINE 50 HOUR SERVICE AND INSPECTION

| | |
|--|------------|
| Accelerator Master (Switch) Box; Drive Control Handle Linkage, check and adjust | 100H 173 |
| Battery, Terminals, Cables, Receptacles, Inspect | 8H 473 |
| Brake Checks, Master Cylinder Level Check | 100H 306 |
| Brake (Deadman) Switch,check | 8H 375 |
| Contactors, Inspect | 100H 673 |
| Direction Switch, check and adjust | 100H 175 |
| Drive Control Handle Linkage,check and adjust | 100H 173 |
| Hydraulic Oil Filter,change | 500H 173 |
| Lift Chain, adjust | 100H 403 |
| Lubricate machine | 100H 772 |
| Pressure Check, Hydraulic System | 1000H 1507 |
| Pump Control Switches,check | 100H 473 |
| Travel Control, Plugging Control, Time Delays (Switch Box) Operating Sequence,check | 100H 178 |

NOTE

PERFORM THIS SERVICE AND INSPECTION
AFTER THE FIRST 50 HOURS OF OPERATION.

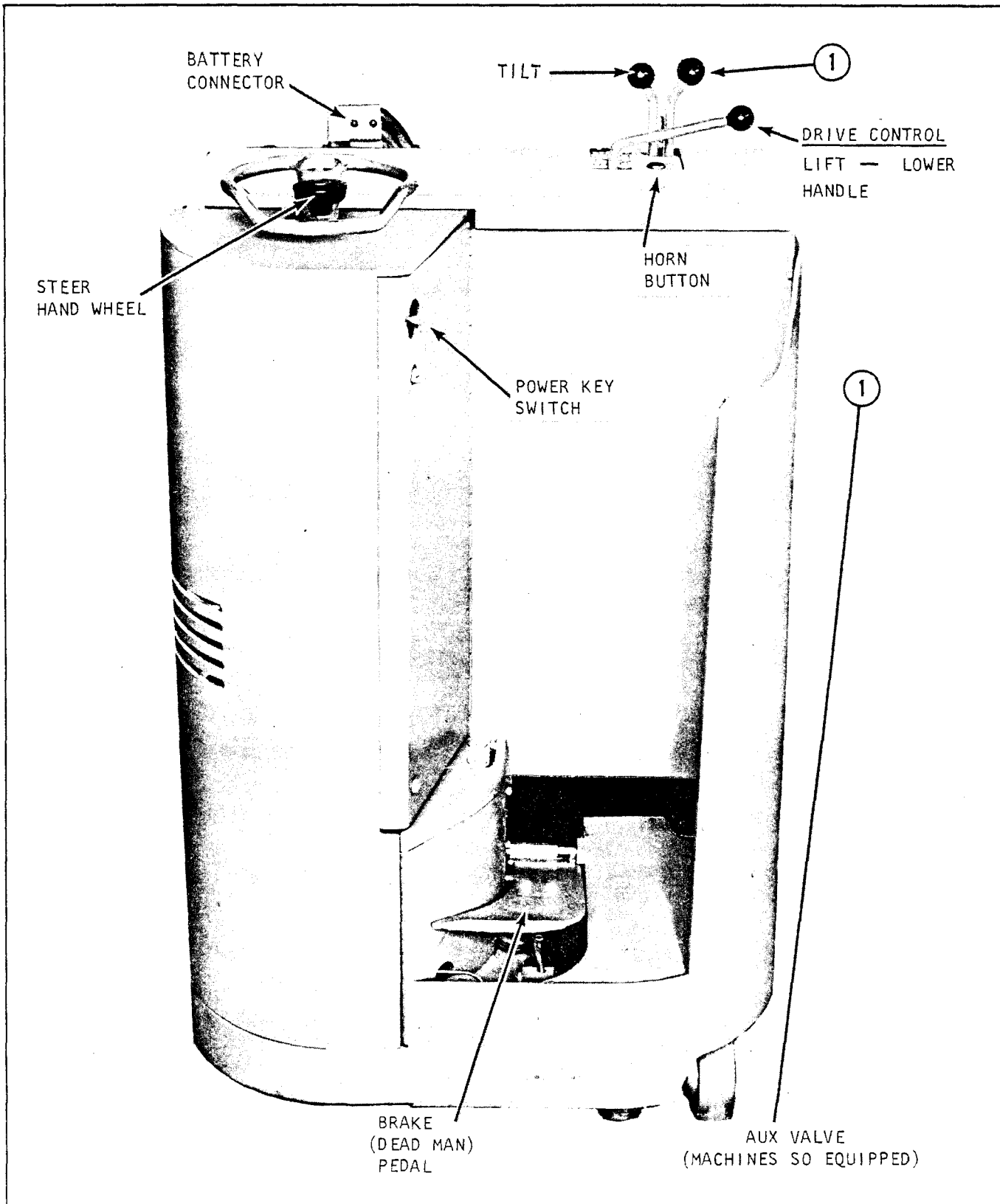

Plate 8262. Overall Controls

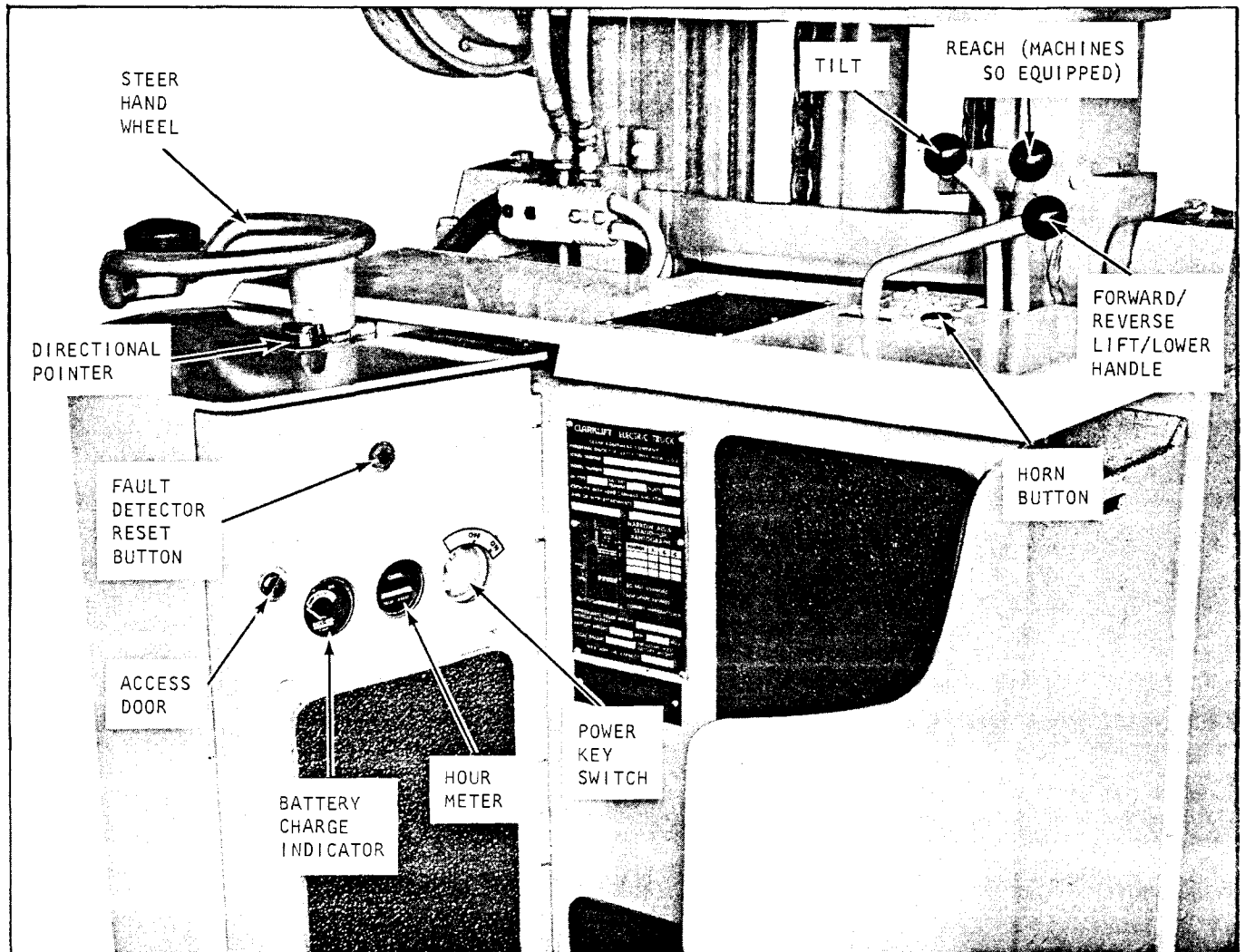

Plate 9460. Typical Overall Controls

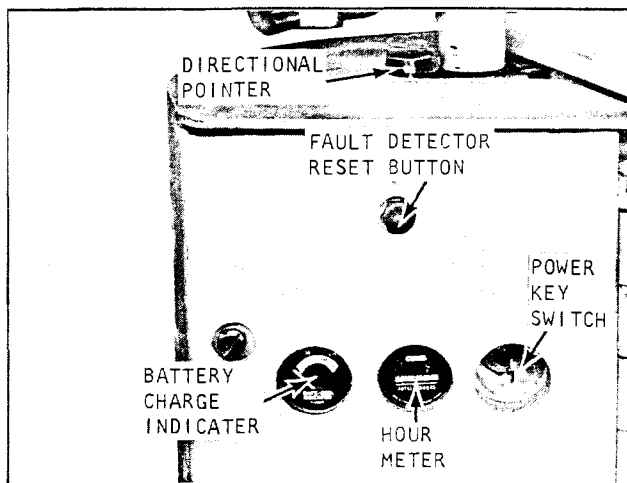
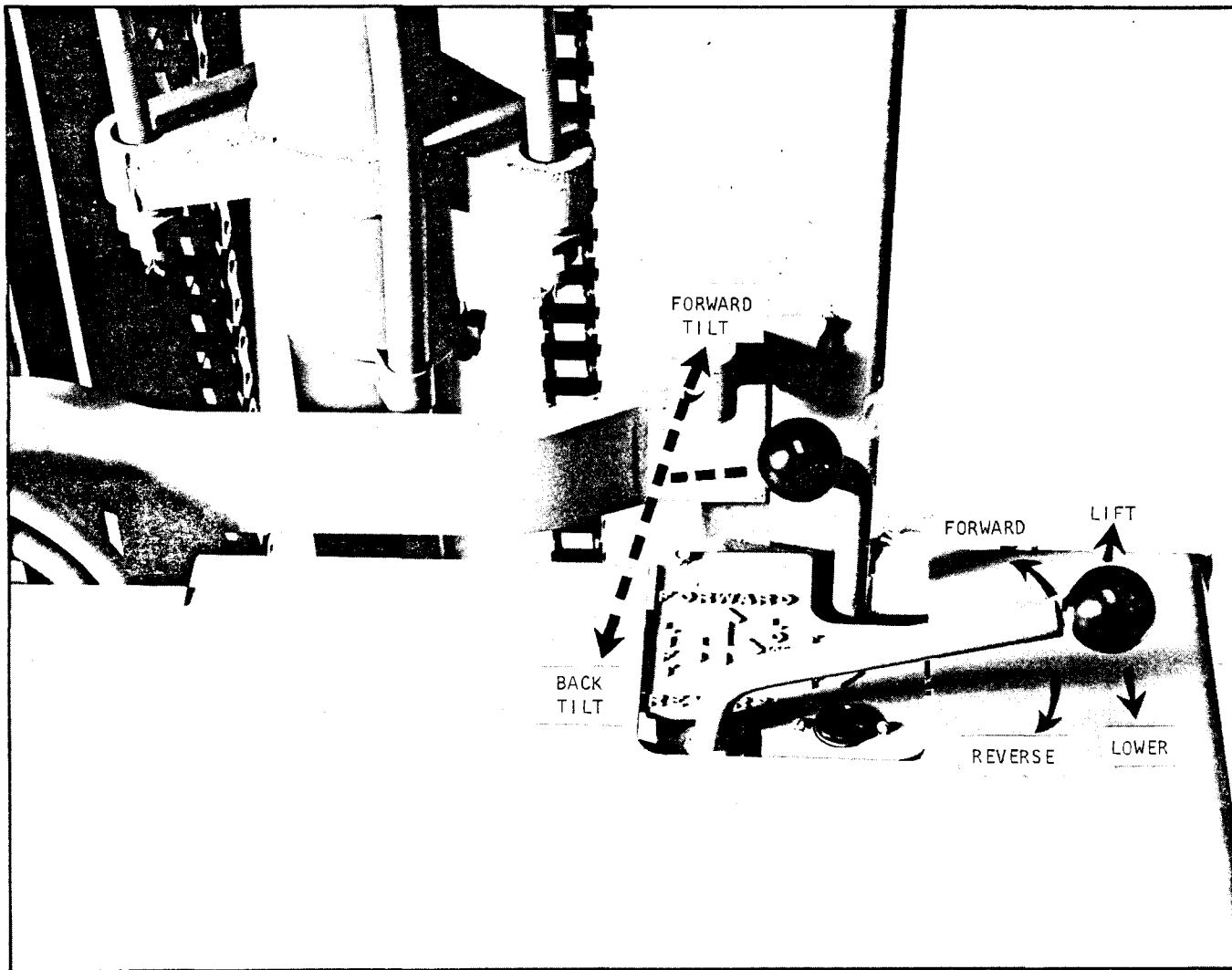

Plate 9461. Typical Instrument Locations

FAULT DETECTOR RESET BUTTON

The fault detector senses current overloads, shorts, etc. in the electrical drive system. When this occurs, the main source of electrical power is shut off by an open circuit. Should the machine stop during some operation, push on the reset button. If this doesn't close the circuit, report to the designated person is authority.



Controls
Plate 8263. Combination Drive and Lift-Lower Control Handle
Tilt Lever

BATTERY CONNECTOR: Connect battery to truck.

POWER SWITCH KEY: Turn key to ON position, and stand on brake (deadman) pedal.

COMBINATION DRIVE AND LIFT-LOWER CONTROL HANDLE: Move control handle forward to go forward and vice versa. The control handle operates an accelerating master control (switch) box that provides the same number of speeds for both forward and reverse. There are four individual speeds with time delay acceleration and plugging control.

The drive control handle also serves to raise and lower the upright lift carriage and load, see Plates 8262 and 8263.

NOTE: Do not hold hydraulic control levers in extreme actuated position after a load has reached its limit. A high oil pressure will result which will heat the oil and cause undesirable high operation temperatures.

C A U T I O N

AVOID OVERLOADING AS THIS SHORTENS THE LIFE OF THE TRUCK AND INCREASES MAINTENANCE.

W A R N I N G

OVERLOADING A TRUCK COULD RESULT IN PERSONAL INJURY — REFER TO SPECIFICATIONS FOR MAXIMUM LOAD CAPACITIES.

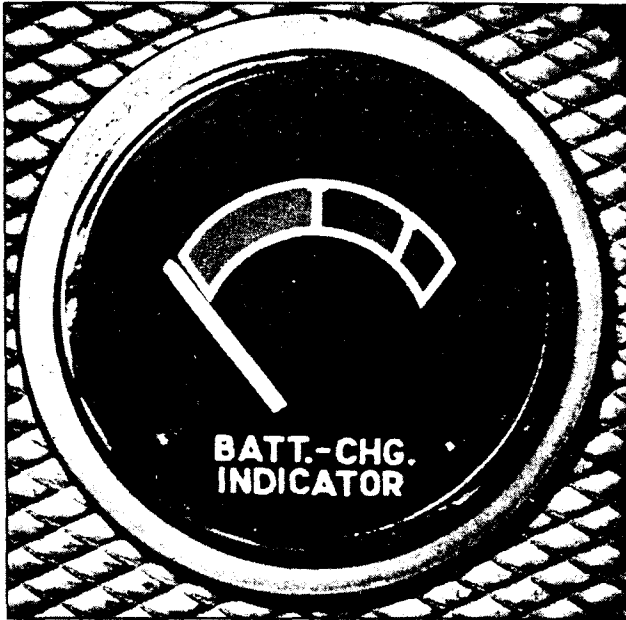

Plate 7515. Battery Charge Indicator

With the key switch in the "on" position, the battery charge indicator will show the available battery voltage. When the indicator needle registers in the red portion of the indicator scale, the battery should be recharged. It is recommended that at this time a specific gravity test be taken with a hydrometer to more accurately determine battery condition.



Plate 7162. Hour Meter

The hour meter accurately records the actual hours of machine operation. This will serve as an aid in determining the time intervals for lubrication and preventive maintenance services.

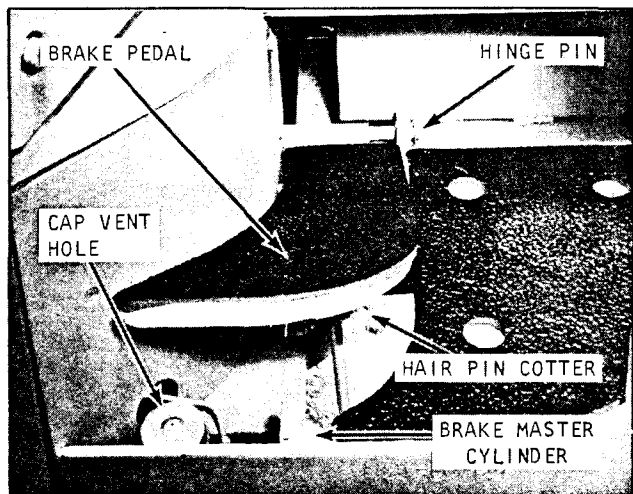

Plate 8264. Brake Pedal

BRAKE AND PARKING BRAKE: The brake pedal is located on the left side of the operator's compartment. The brake is designed to actuate as the brake pedal is released from the down position — driver steps off pedal. Partial brake applications (slowly releasing pedal) allows the driver to brake gradually.

Before the brake is applied, a deadman switch is actuated and all electrical power is shut off to the drive motor. It is impossible to operate the truck with the pedal in the UP position.

Although the brake is released by hydraulic pressure, it is spring-applied and therefore

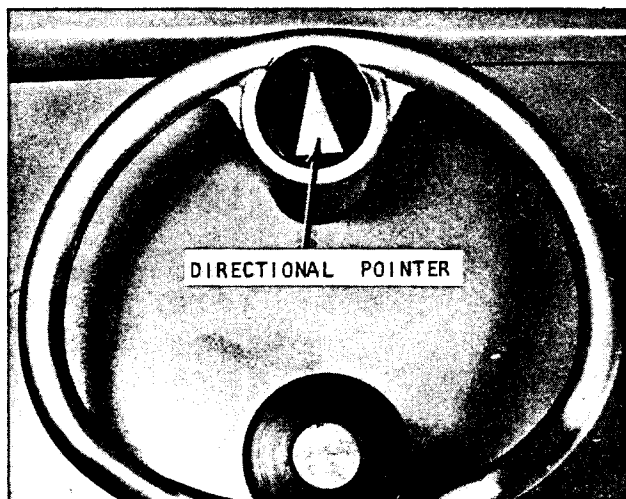

Plate 7513. Steer Wheel with Directional Pointer

serves as a safe parking brake. **NOTE:** Always turn power key switch to the OFF position when leaving truck.

STEERING: A horizontal steering wheel (shown above) is connected to the steerable drive wheel by roller chains and sprockets thus providing approximately 180° steering.

A "directional pointer" located on the top side of the steer wheel (see above) indicates the direction in which the steer/drive wheel is facing.

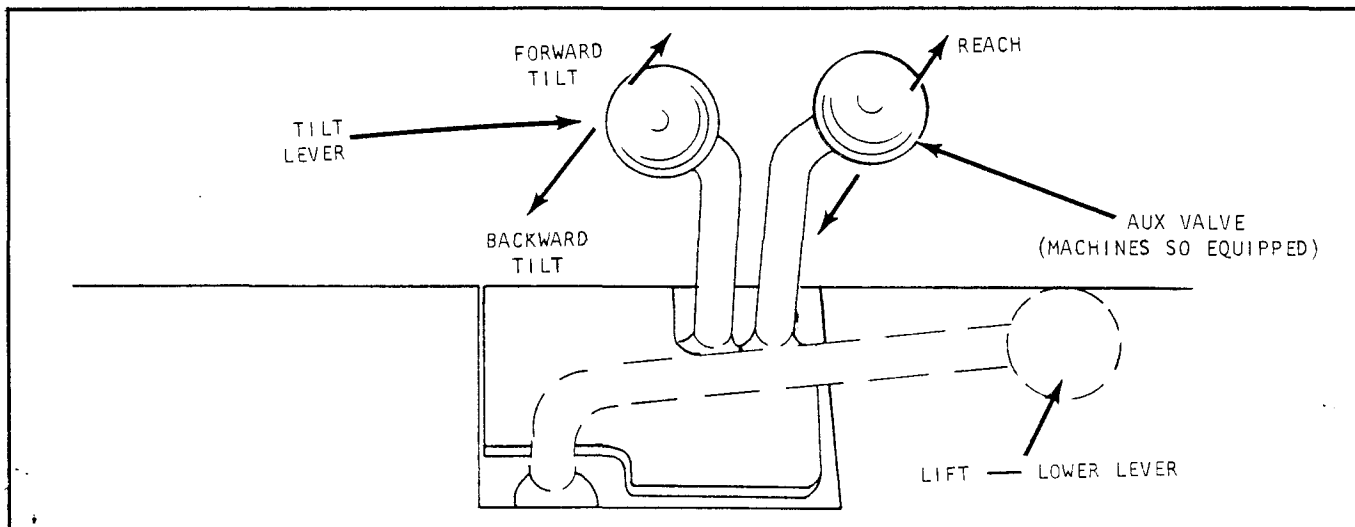

Plate 8280. Hydraulic Control Levers



INDUSTRIAL TRUCK DIVISION



OPERATIONS

16. Be sure the brake is in proper working condition. Be sure all mechanical and electrical components are working correctly.
17. When climbing or descending steep grades with a load, rear of truck (driver's end) should be downhill to maintain weight on the drive tire for traction and braking — and to prevent load from sliding off the forks.
18. The operator should be qualified (preferably examined and licensed) and drive in accordance with his company's safety rules.



INDUSTRIAL TRUCK DIVISION



LUBRICATION AND PREVENTIVE MAINTENANCE INDEX

| | Time Interval & (H-Hours) | Page Number (0000-) | | Time Interval (H-Hours) | Page Number (0000-) |
|---|---------------------------------|---------------------------|---|-------------------------------|---------------------------|
| (8 HOURS) | | | (100 HOURS cont'd) | | |
| Battery Charge Indicator..... | 8H | 273 | Lift and Tilt Switches, Check | 100H | 473 |
| Battery Service, Check & Maintenance..... | 8H | 473 | Lift Carriage (Pantograph), Inspect | 100H | 403 |
| Battery Removal & Install..... | 8H | 479 | Lift Chain, Check & Adjust | 100H | 403 |
| Brake (Deadman) Switch Check.. | 8H | 375 | Lift, Reach and Tilt Cyl., Operation, Check | 100H | 403 |
| Hour Meter..... | 8H | 273 | Lubrication Chart..... | 100H | 772 |
| Hyd. Sump Tank, Level Check... | 8H | 503 | Lubrication Key & Inst.... | 100H | 773 |
| (100 HOURS) | | | Lubricate Machine..... | 100H | 403 |
| Accelerating Master Control (Switch Box) operating sequence | 100H | 180 | Off-Set Arm, Check & Adj. | 100H | 183 |
| Accelerator Master (Switch) Box Drive Control Handle Linkage, Check | 100H | 173 | Plugging Control, Check and Adjust..... | 100H | 178 |
| Brake Cylinder Pivot Arm & Pedal Rod, Check and Adjust | 100H | 302 | Service-Parking Brake, Check and Adjust | 100H | 306 |
| Brake (Deadman) Pedal, Check and Adjust | 100H | 302 | Switch Box Maintenance.... | 100H | 179 |
| Combination Drive and Brake Control Rod, Check and Adjust | 100H | 182 | Switch Box Trouble Shooting | 100H | 179 |
| Contactors, Inspect | 100H | 673 | Switch Box I M.S. Switch and Directional Switch, Check & Adjust | 100H | 176 |
| Deadman Rod Adjustment - Illustration | 100H | 184 | Switch Box Time Delays (operating sequence).... | 100H | 178 |
| Deadman Rod, Check and Adjust | 100H | 182 | Travel Control, Check & Adjust | 100H | 178 |
| Directional Switch, Check and Adjust | 100H | 175 | (500 HOURS) | | |
| Drive Control Adjustment (upper portion) illus..... | 100H | 181 | Caster Adjustment | 500H | 473 |
| Drive Control Adjustment (lower portion) Check and Adjust | 100H | 182 | Sump Tank (Breather) Filter, Check | 500H | 174 |
| Drive Unit, Lubricant Level Check | 100H | 073 | Sump Tank, Drain & Refill. | 500H | 174 |
| Hydraulic Control Valve and Lines, Inspect | 100H | 403 | Sump Tank Filter, Change.. | 500H | 174 |
| Hydraulic Sump (Breather) Filter, Check | 100H | 503 | (1000 HOURS) | | |
| | | | Brake Bleeding Procedures | 1000H | 912 |
| | | | Drive Motor Brush Spring Tension, Check | 1000H | 674 |
| | | | Drive Motor, Inspect | 1000H | 673 |



INDUSTRIAL TRUCK DIVISION



LUBRICATION AND PREVENTIVE MAINTENANCE INDEX

CONTINUED

| (1000 HOURS cont'd) | Time Interval & (H-Hours) | Page Number (0000-) | LUBRICATION & PREVENTIVE MAINTENANCE ILLUSTRATIONS | | |
|--|---------------------------|---------------------|--|---------------------------|---------------------|
| | | | Description | Time Interval & (H-Hours) | Page Number (0000-) |
| Drive Unit Drain & Refill... | 1000H | 1307 | | | |
| Hydraulic System Checks (Flow and press. at pump)... | 1000H | 1573 | Lube. & Prev. Main. illus. | 8H | 000 |
| Lift Carriage (Pantograph) Rollers, Check & Adjust... | 1000H | 1811 | Lube. & Prev. Main. illus. | 100H | 000 |
| | | | Lube. & Instruction Diagram | 100H | 772 |
| Pump Drive Motor Brush Spring Tension, Check | 1000H | 774 | Lube. & Prev. Main. illus. | 500H | 000 |
| Pump Drive Motor, Inspect... | 1000H | 773 | Lube. & Prev. Main. illus. | 1000H | 000 |
| Roller Lubrication | 1000H | 1815 | | | |
| Upright Roller, Adjustment Checks | 1000H | 1803 | | | |

NOTE

WHEN PERFORMING THE 100, 500 OR 1000 HOUR LUBRICATION AND PREVENTIVE MAINTENANCE, ALWAYS INCLUDE THE PREVIOUS LUBRICATION AND PREVENTIVE MAINTENANCE SCHEDULES.

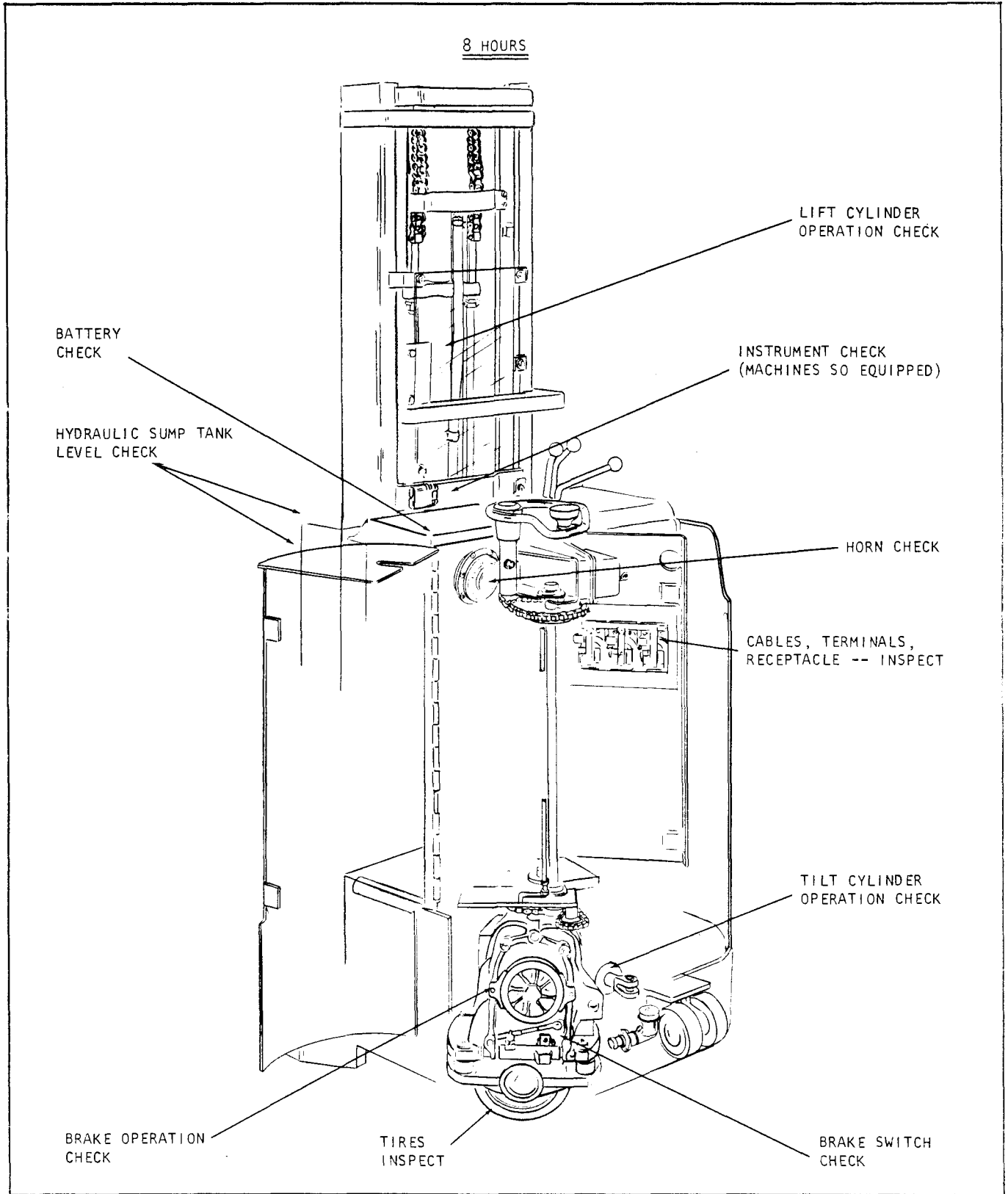

Plate 8269. Lubrication & Preventive Maintenance Illustration



Plate 7515. Battery Charge Indicator

With the key switch in the "on" position, the battery charge indicator will show the available battery voltage. When the indicator needle registers in the red portion of the indicator scale, the battery should be recharged. It is recommended that at this time a specific gravity test be taken with a hydrometer to more accurately determine battery condition.

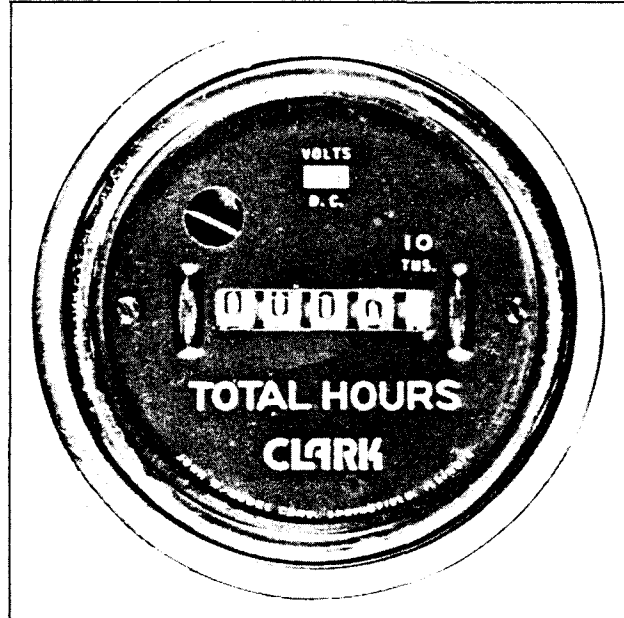

Plate 7162. Hour Meter

The hour meter accurately records the actual hours of machine operation. This will serve as an aid in determining the time intervals for lubrication and preventive Maintenance services.

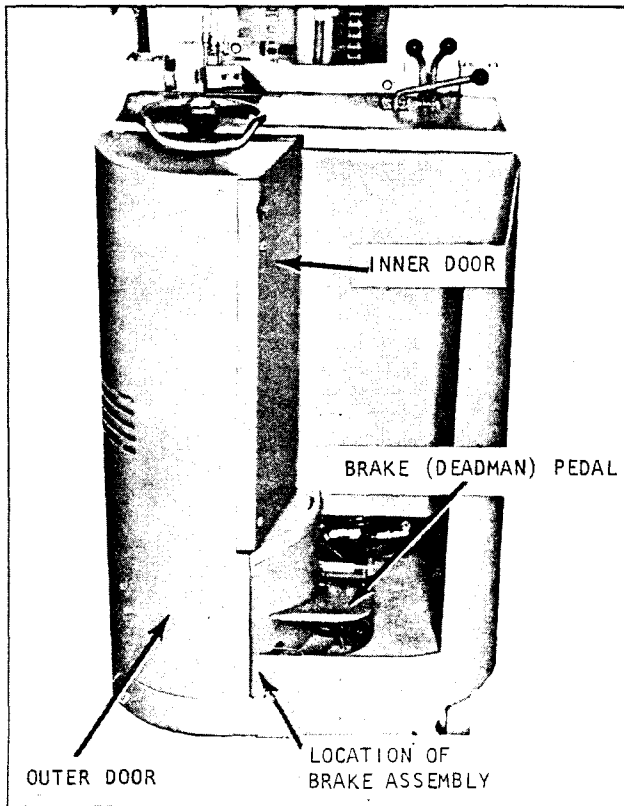

Plate 7535. Location of Brake Assembly

**BRAKE (DEADMAN) SWITCH
ADJUSTMENT CHECKS**

1. Turn key switch off.
2. Open both inner and outer doors.
3. Rotate steer hand wheel so the brake assembly is visible from rear of truck.
4. Depress and then release brake pedal. Brake switch should open (actuate) before R.H. brake shoe contacts brake drum.

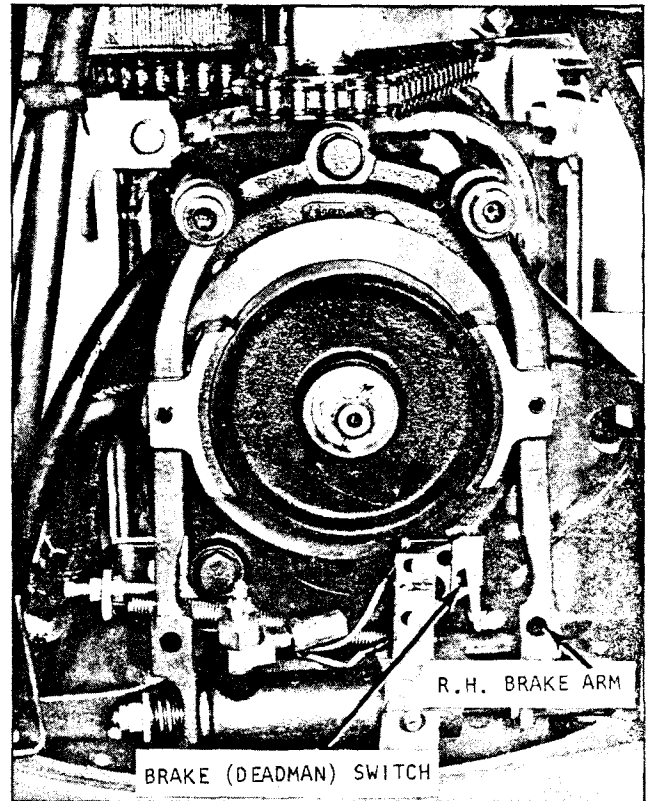

Plate 7536. Brake (Deadman) Switch Adjustment

As the driver releases pedal from the down position, which should contact brake arm and actuate just before the brake shoe (located on the switch side) contacts brake drum. If an adjustment is necessary, refer to page 100H 303.

Brake switch adjustment is important. The switch must actuate, cut electrical current to the drive motor, before the brake shoes touch brake drum. If correct adjustment is not maintained, lining wear will increase, heating of the drive motor will result as the motor is trying to operate against the brake.



INDUSTRIAL TRUCK DIVISION



LUBRICATION AND PREVENTIVE MAINTENANCE

BATTERIES - LEAD-ACID

The lead-acid battery has a lead peroxide positive plate, a sponge lead negative plate, and the electrolyte is a solution of sulphuric acid.

The battery does not store electricity. When the battery is connected to an electrical circuit, a chemical reaction starts inside the battery. This chemical action produces lead sulphate on both the positive and negative plates, and the chemical actions produces the electric current through the electrical circuit. This action continues only as long as the circuit is complete from negative pole to the positive pole. As the battery plates become coated with lead sulphate the voltage output of the battery decreases. When both the positive and negative plates have become thoroughly coated with lead sulphate, both plates act alike (or like similar metals). This causes the current to stop flowing.

When the point is reached where the battery is discharged, the battery must be charged. Charging is accomplished by connecting the battery to a direct current source in such a manner that the electricity flows through the battery in the opposite direction of the normal battery current.

BATTERY LIFE

Economical and efficient operation of the electric fork lift truck depends, to a great extent, upon the efficiency and life of the battery.

During the operation of the fork lift truck, many things occur which, if not corrected or prevented, can greatly reduce the life of the battery.

The operator should be acquainted with the limits, capacities and capabilities of his truck. He should know the correct point of power to use to move all loads up to the rated capacity of the truck.

Batteries are rated in ampere hours over a set period of time, and should be of a proper size for the particular work intended. Extending the work means over-discharging the battery. This will greatly shorten its life. Overcharging the battery by using too high a rate of charge, will cause it to gas vigorously after it has reached its fully charged state and will also shorten its life.

If service requirements demand only partial discharge of the battery, it is unnecessary to recharge following each partial discharge. When the hydrometer reading indicates the battery is 75% discharged, (approximately 1130 specific gravity) arrangements should be made to recharge.

Controlling the "charge" and "discharge" of the battery is a very important contributing factor in determining battery life.

The discharge of a battery can be controlled in several ways.

Batteries are rated according to the job for which they are being used. A fully charged battery is capable of doing a certain amount of work or lasting a certain length of time in a specific service. With information of this type, a schedule or duty cycle can be worked out and the batteries can be changed or serviced with very few failures.

Experienced operators can tell from the action of the truck, when the battery is reaching the point where it should be charged or changed. Prompt action in seeing that the battery is serviced at this time can result in longer battery life.

Several "meters" or "indicators" are available for use on battery powered trucks. These indicators show the operator the state of charge of the battery, how much useful power is left in the battery, or just simply warns the operator when the battery should be charged.

MAINTENANCE

Keep the "tops" of the battery clean and dry at all times. Normally wiping the top of the battery with a damp cloth is sufficient. If the battery is removed from the truck, it can be hosed off with clean water. If electrolyte is spilled, it will not dry off. Neutralize the acid with a solution of ordinary "bicarbonate of soda" and rinse thoroughly with clean water.

A light coating of vasoline or a light cup grease on the terminals will help prevent corrosion. If the terminals have become corroded, wash off the corrosion with a soda solution and rinse thoroughly.

The vent plugs should be in place at all times when using, cleaning, and charging the battery. They should be cleaned weekly by immersing in a bucket of clean water for one half hour. Check the vent holes in the vent plugs and clean out.

The vent holes must be open to allow gas to escape from the cell.

The batteries should be numbered and assigned to a given truck. A record should be kept of (1) daily hydrometer reading on a pilot cell at the beginning of each charging, (2) a weekly reading of the pilot cell after charge, and (3) a hydrometer reading of all cells and temperature of one cell each "4" months before and after charging. When battery shows nonuniformity of these readings and an inability to work through a shift, it is an indication that replacement is necessary.

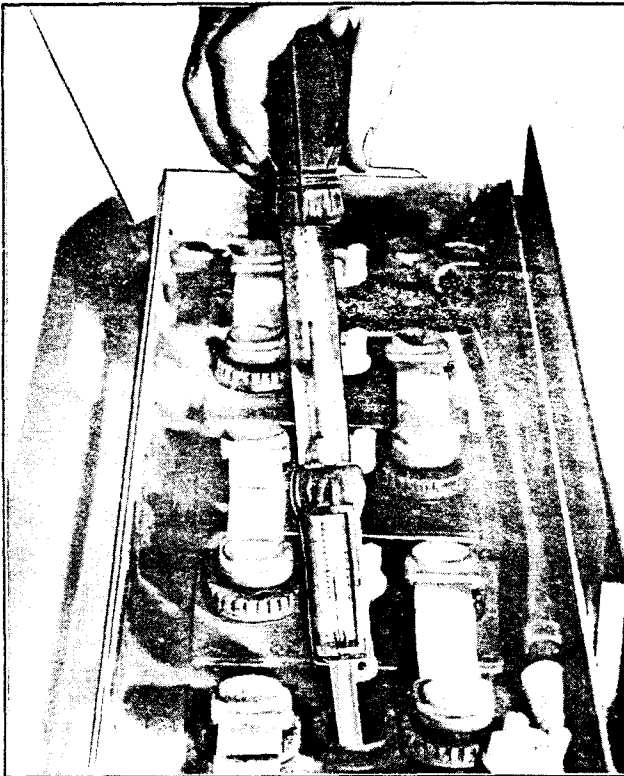

Plate 4018. Hydrometer Check Method

TWO-RATE CHARGING

"Two-Rate" charge, as the name implies, consists of two average rates. A "high" rate is provided at the beginning of the charge, while, toward the end of the charge, this is automatically changed to a "low" rate. (In actual operation, both high and low-rate is obtained in modern charging equipment by the use of a voltage relay in a rate charging circuit). When the battery cell voltage rises to approximately 2.37 volts per cell, at

77° F., the voltage relay automatically lowers the charging rate. The same voltage relay operating with a time switch can also be used to stop the charge automatically.

"Two-Rate" charging is generally used with rectifiers, although it is also used with a generator when the voltage is too high for the taper charge. For dependable, day-in and day-out repeat performance, the quality of the voltage relay and time switch is important.

TAPER-CHARGING

The "Taper" charge (Modified constant potential) is obtained inherently (a natural characteristic) in a circuit design by balancing the charging voltage source against the battery voltage rise during charge. As the battery voltage rises, it approaches the value of the charging source and hence, there is less difference between the charging source and battery voltage. As a consequence, the flow of charging current will taper off in value opposite to the way the battery voltage rises.

"Taper" charge requires a close tolerance (plus or minus 3%) of charging source voltage (2.63 times the number of cells) when more than one charge circuit is on the same machine. A single circuit taper charge does not need this close voltage limit as the inherent taper is obtained as a natural part of the shunt generator load characteristic.

However, taper charge circuits are specifically designed for a definite number of cells, in the battery, to achieve the inherent taper. The only duty performed by a voltage relay time switch control, on the taper circuit, is to stop the charge.

NICKEL-IRON-ALKALINE STORAGE BATTERIES

The alkaline storage battery is known as the "nickel-iron-alkaline type" because nickel oxide is used in the positive elements, and iron in the negative elements; while the electrolyte is an alkaline solution containing potash and lithia.

TYPE AND SERIES

Each cell bears a distinguishing type letter and size number plainly stamped upon the cover. A serial number, just under the type letter and size number combination, denotes date of manufacture. All cells having the same type letter are similar in operating characteristics and



INDUSTRIAL TRUCK DIVISION



LUBRICATION AND PREVENTIVE MAINTENANCE

are made from the same class of plates and size. Therefore, the capacity of the cell simply varies with the number of plates. The "size number" indicates the number of positive plates. The total number of positive and negative plates is one more than twice the size number.

INSPECTION ON RECEIPT

Alkaline batteries are shipped in either a "charged" or "discharge" condition. The cells shipped charged, are intended for service within a short time without further charging. If the cells are not put into service within a month, it will be found advisable to charge one or two hours before using.

A red label, included with the battery in each shipment, indicates that the cells are charged ready for immediate use on receipt.

A green label, indicates that the cells are in a discharged condition and must be given an extra charging time as specified by the manufacturer.

Upon receipt of the battery, inspect each cell for solution height. Use a glass tube for this purpose. DO NOT use a match or other open flame for inspection.

If electrolyte has been spilled, if plate tops are visible above the surface of the solution, or if the inside of packing case, etc., shows yellowish stains. The loss must be replaced; preferably with Refill Alkaline Storage Battery Solution, or lacking this, with RENEWAL Solution diluted to a specific gravity of 1.215 by the addition of distilled water. The proper height of solution above plate tops is as follows: Cell type is stamped on the cover of each cell.

- "A" Type Cells - 1/2"
- "C" Type Cells - 1"
- "D" Type Cells - 1 1/4"

When the level of solution is only a small amount below the proper height, fill with pure distilled water and in the future, use pure distilled water for replenishing the solution.

CONNECTIONS

The positive pole of an "alkaline cell" is designated by a red bushing around the pole and a plus (+) mark stamped on the cell cover.

The negative pole, is designated by a black bushing around the pole; no designating mark on the cover.

The connections between cells, in a tray, are made of solid wire with lugs on both ends. These are known as "connectors". The flexible, rubber-covered cables used to join trays together are known as "jumpers".

To avoid unnecessary electrical losses, all electrical connections must be tight. (To obtain this, it is necessary to see that all the contact surfaces between the poles and lugs are clean and make good contact.) Remove any Esbaline, grease, or dirt that may stick to the tapered surfaces of the poles or the inside of the lugs before connecting. If necessary, use 00 sandpaper or 00 emery cloth for this purpose. NEVER use a file or anything that will harm the contact surfaces.

A loose or dirty contact on a cell pole will cause excessive heating, and may be detected by touching the connectors after the current has been passing through them for some time.

DISCONNECTING LUG

A "disconnecting jack" or "lug puller" is supplied with each battery. This jack is designed to straddle the connector or jumper lug and, by means of a jack screw, break the lug loose from the cell pole.

CHARGING

Direct current must be used to charge any storage battery. If only alternating current is available, it is necessary to convert to direct current by the use of a motor generator set, mercury arc rectifier, or other suitable form of current rectifier.

An alkaline battery may be charged at either a constant current rate throughout the entire charging period, or at a modified constant potential rate. In either case the average rate should be such that the battery can be brought from a discharged state to full charge within between six and seven hours. In connecting a battery to the charging circuit, always connect the positive terminal to the positive side of the line, and the negative terminal to the negative side of the line.

It is not necessary to take specific gravity reading during charge, as the electrolyte does not change appreciably.

Before starting to charge, see that the solution is at the proper level. If the solution is low, bring it to the proper level by adding pure distilled water as instructed under watering. If the battery is in a compartment, open the cover before starting a charge. DO NOT charge in a hot place or allow the temperature of the solution to exceed 115° Fahrenheit on charge.

CHARGE TEST FORK

The charge test fork was developed to provide an easy means of determining the state of charge of an alkaline battery.

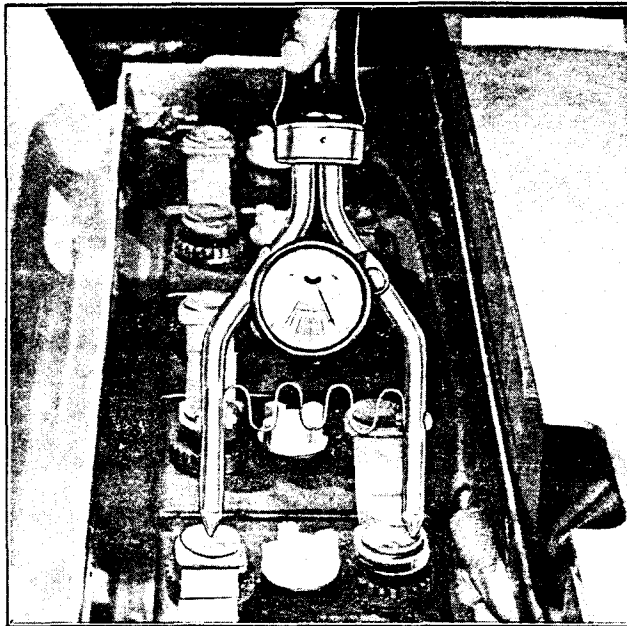

Plate 4008. Charge Test Fork Check

This is done by obtaining a key voltage reading which, on reference to the charts supplied for use with instrument, will indicate the amount of charge necessary to restore the battery to a fully charged condition.

ELECTROLYTE

The specific gravity of the electrolyte in fully charged alkaline cells has a normal operating range of between 1.215 and 1.160, with electrolyte at the proper level and corrected for temperature.

The specific gravity reading of the electrolyte (of an alkaline cell) has no value in determining its state of charge, as the specific gravity does not change during the charging or discharging periods

to any marked extent. It, therefore, is only necessary to take infrequent readings, to determine if the specific gravity has dropped to the point where a change of electrolyte is desirable.

There are two kinds of alkaline potash electrolyte which are normally used when a "change" of solution is found necessary. Renewal solution, which has a specific gravity of approximately 1.250; is normally used to replace old electrolyte, the gravity of which has dropped to the low limit ranging between 1.160 and 1.170. Refill solution has a specific gravity of approximately 1.215 and is used to replace spillage. DO NOT use any potash solution other than alkaline electrolyte, as the presence of impurities or improper compounding of such solution may permanently injure your battery.

WATERING CELLS

Before putting a new electric filler into service; see that the tank is washed thoroughly to remove any foreign matter and then rinse tank, hose and filler thoroughly by running distilled water through them. Then fill the tank with distilled water and mount in a convenient place at least four or five feet above the cells to be watered.

To operate, insert the nozzle into the filler opening in the top of the cell. If the solution is already at the proper height, the bell signal will ring. If bell does not ring, start flow of water by opening valve by pushing down lever on filler handle. When the bell rings, remove the nozzle from the cell, close cell filler cap and proceed to next cell.

LAYING UP BATTERY

If battery is to be laid up for any length of time (in excess of one year) be sure that the plates are covered to the proper height with solution and that the battery is discharged and short circuited. The battery should be stored in a cool dry place.

Alkaline batteries are easy to lay up. Merely discharge to zero voltage and short circuit. They may be left standing idle indefinitely, without injury, if stored in this short circuited condition. The battery may be stored for 6 months to a year without discharging and short circuiting.



INDUSTRIAL TRUCK DIVISION



LUBRICATION AND PREVENTIVE MAINTENANCE

C A U T I O N S

NEVER put lead battery acid into an alkaline battery or use utensils that have been used with acid; you may ruin the battery.

NEVER bring a "lighted match" or other "open flame" near a battery.

NEVER lay a "tool" or any piece of "metal" on a battery. Always keep the filler caps closed except when necessary to have them open for filling as provided for in these instructions.

ALWAYS keep batteries clean and dry externally.

ALKALINE ELECTROLYTE is injurious to the skin or clothing and must be handled carefully. Solution spilled on the person should be immediately washed away with plenty of water.

DO NOT use the electric filler, or fill cells while a battery is on charge.

USE ONLY pure distilled water for watering the battery.

WEAR GOGGLES when cleaning or changing solution.

CABLES, TERMINALS AND BATTERY RECEPTACLE.

Check cables, terminals and receptacle for condition and security of mounting. Correct as necessary.

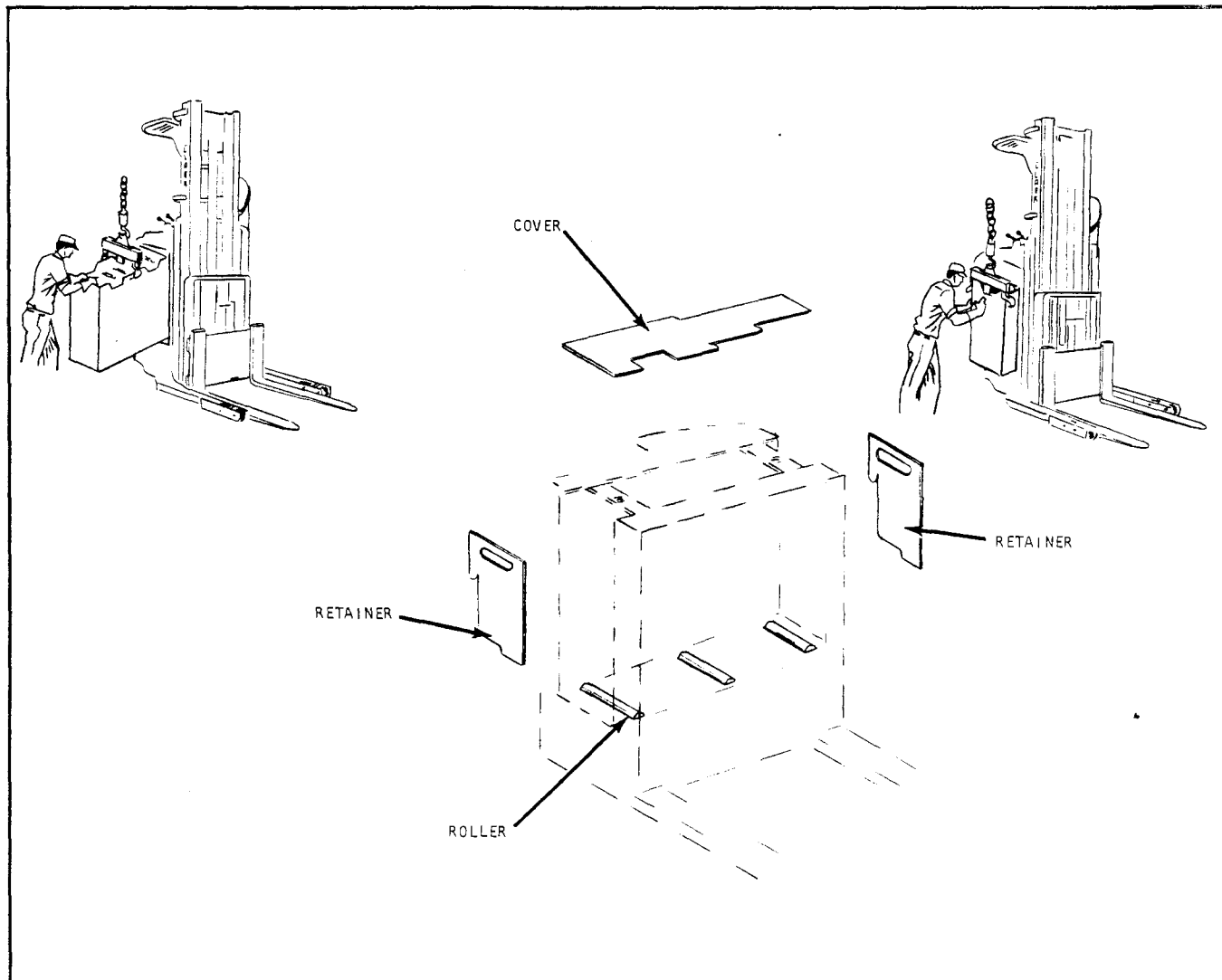

Plate 7520. Battery Installation

BATTERY

The battery is mounted on three (3) rollers and may be removed from either side of the machine. Lifting slots are provided in the battery casing for ease in handling.

NOTE

THE BATTERY MAY BE SERVICED IN THE VEHICLE BY REMOVING THE BATTERY BOX COVER.

BATTERY INSTALLATION

Remove battery box cover and one battery retainer. Place battery carrier in center slots of battery. Use chain hoist to lift battery into position and slide battery into compartment as far as hooks will allow (see above).

CAUTION

BE SURE BATTERY IS RESTING SECURELY ON TWO ROLLERS SO THAT IT WILL NOT TIP OR FALL WHEN CARRIER IS REMOVED.

Remove carrier from battery and slide battery into position, as shown above, then install battery retainer and cover.

WARNING

DO NOT ALLOW CHAIN HOIST, OR BATTERY CARRIER OR ANY METAL OBJECT TO COME IN CONTACT WITH CELL CONNECTORS, TERMINAL POSTS ETC., THUS CAUSING A DIRECT SHORT RESULTING IN BATTERY DAMAGE, AND POSSIBLE PERSONAL INJURY.

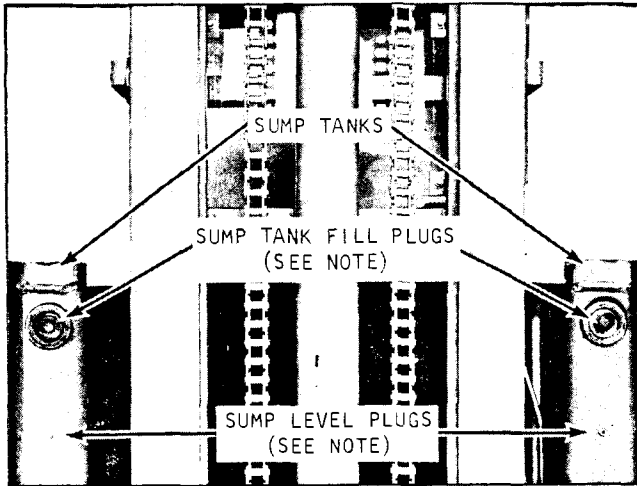

Plate 7528. Hydraulic Sump Tanks

HYDRAULIC SUMP TANKS, LEVEL CHECK

Check hydraulic sump fluid level in following manner:

1. Lower upright.
2. Remove oil level plug — hydraulic fluid should be at level of hole.
3. Remove breather filter plug and inspect. Be sure breather holes are not plugged, replace filter if dirty.

If necessary, fill sump to proper level using Hydraulic Fluid per Clark Specifications MS-68, Clark Part number 885385. Install plugs and operate valve control levers to allow any air in the lines to escape, then recheck sump fluid level before placing machine in operation.

HYDRAULIC CONTROL LEVER

I M P O R T A N T

EVERY 8 OPERATING HOURS (OR EVERY SHIFT)
ELEVATE UPRIGHT TO UPPER LIMIT TO LUBRI-
CATE THE TOP PORTION OF LIFT CYLINDER.

Check lift, tilt, and reach (if applicable) operation. The cylinders should actuate when control levers are moved either way from neutral position.

When a load is elevated and the control levers are in neutral position, the load should remain stationary with no noticeable downward, backward, or forward drift. If load drifts excessively — report to proper person in authority.

C A U T I O N

NEVER ALLOW THE LIFT CARRIAGE TO REMAIN
IN AN ELEVATED POSITION FOR ANY PROLONGED
PERIOD. LIFT CARRIAGE SHOULD BE LOWERED
WHEN NOT IN USE.

DO NOT HOLD CONTROL LEVERS IN EXTREME
POSITIONS AFTER THE UPRIGHT OR LIFT CAR-
RIAGE HAS REACHED ITS LIMIT OF TRAVEL.
TO DO SO WILL RESULT IN HIGH HYDRAULIC
OIL PRESSURES AND POSSIBLE OVER-HEATING OF
THE OIL.

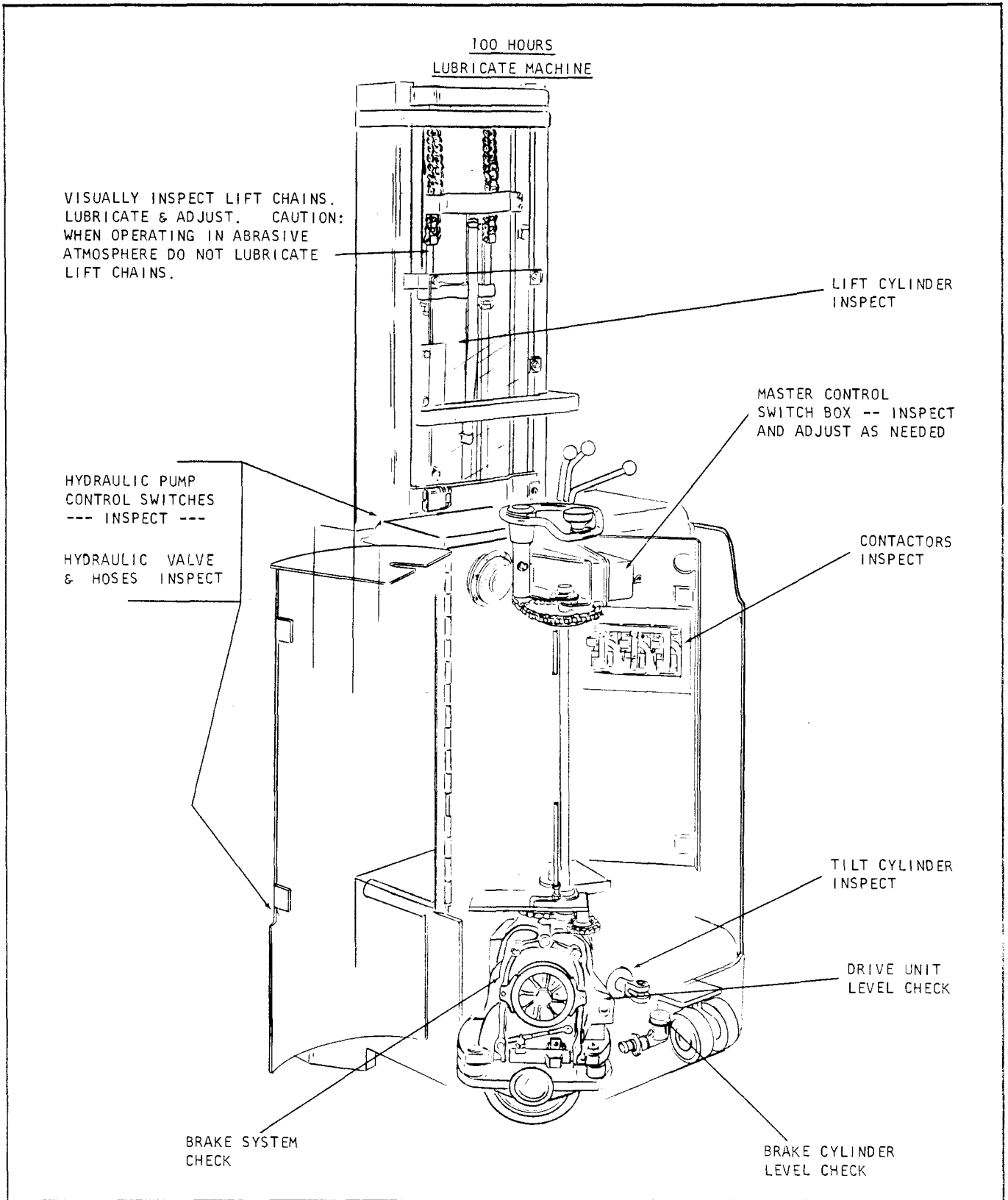

Plate 8270. Lubrication & Preventive Maintenance Illustration

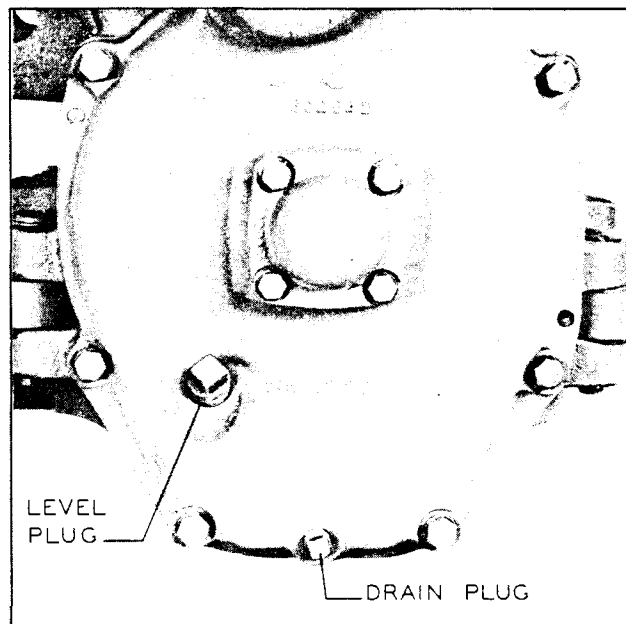

Plate 4274. Drive Unit Assembly

DRIVE UNIT LUBRICANT LEVEL CHECK

Verify lubricant level, fill if necessary with S.A.E. number 90 gear lubricant.

Clean dirt from around level plug and remove the plug. Fill until lubricant reaches the height of the level plug opening. DO NOT overfill as the excess quantity will serve no useful purpose. If the oil level is too high, it will cause excessive oil churning and attendant high oil temperature and possible leakage.

After drive unit has been filled to the proper level, replace level plug.

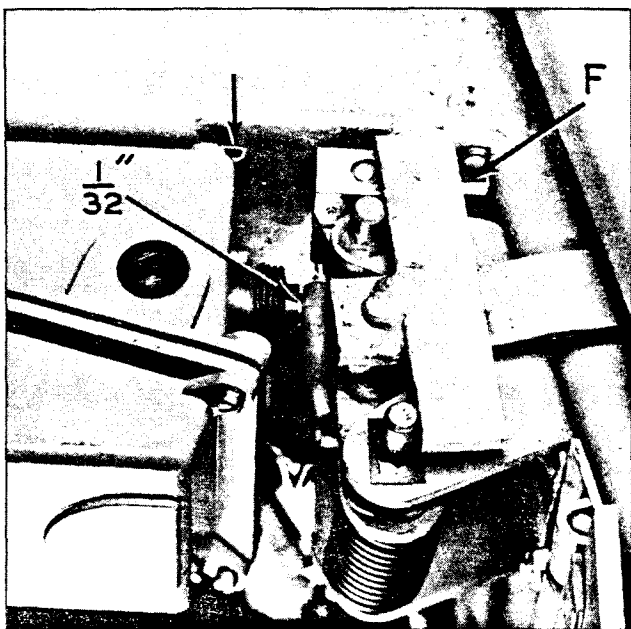

Plate 7483. Neutral Position Brake (Deadman) Pedal in the UP position. Switch Box adjusted for Plunger extension of 1/32" from full retracted position.

WARNING

MAKE ALL ADJUSTMENTS WITH POWER SWITCH KEY IN THE "OFF" POSITION.

1. With control handle linkage in neutral position (as shown above), switch box should be adjusted so that plunger is 1/32 inch from full retracted position.

The frame is provided with elongated holes (shown above, see arrow) for adjustment purposes. First, check adjustment by depressing plunger inward with a screwdriver. Plunger should move inward 1/32 inch. If adjustment is necessary, loosen switch box mounting screws and move box in direction necessary. Tighten screws and recheck adjustment.

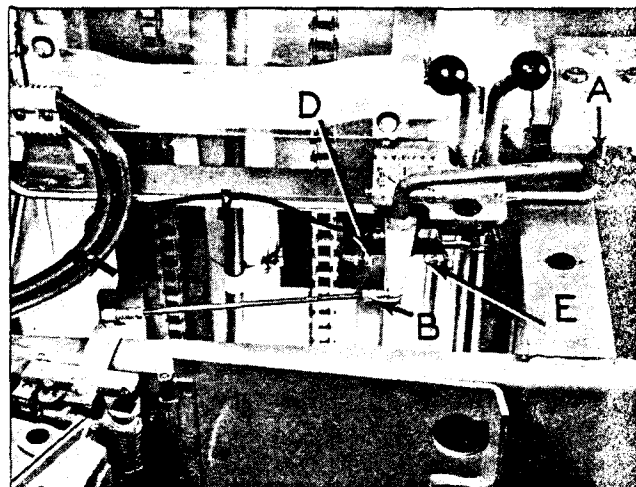

Plate 7484. Control Handle (A) in neutral position. Ball Joint (B) adjusted so control arm is on center line of the mounting bracket. Center by adjusting Stops (D & E shown above).

2. With Control Handle in neutral position, the control arm should be on center line of mounting bracket (see above).

If centering adjustment is necessary, remove Ball Joint (B) from ball joint stud by slipping the spring applied sleeve, of the joint, sideways so joint may be pulled free of stud. Now, screw the ball joint in direction necessary to put control arm on center line of mounting bracket. Reinstall and tighten jam nuts.

ACCELERATING MASTER (SWITCH) BOX AND
DRIVE CONTROL HANDLE LINKAGE
CHECKS AND ADJUSTMENTS

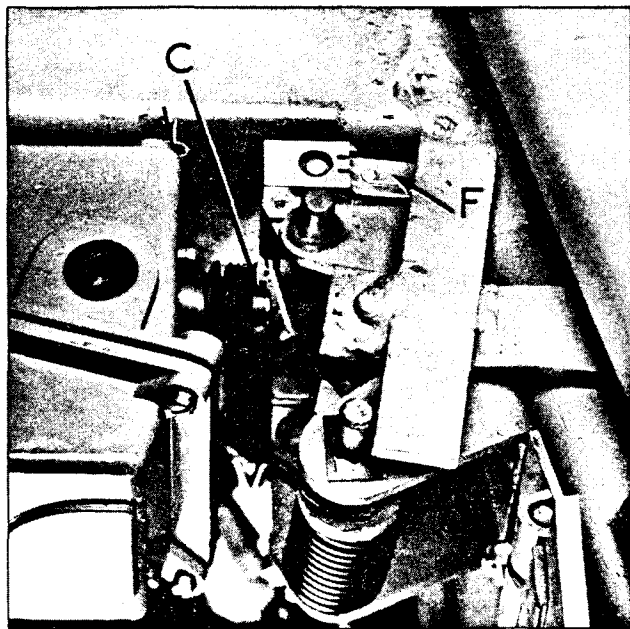

Plate 7485. Control Arm Actuated FORWARD. Brake (Deadman) Pedal in the DOWN position.

3. Step on brake (deadman) pedal. Move control handle REARWARD until control arm contacts Stop (D), see Plate 7484. Plunger (C) should extend approximately $7/8$ inch from the switch box (see above).

If adjustment is necessary, loosen jam nut on Stop (D), see Plate 7484, and rotate stop in direction necessary to obtain correct adjustment. Tighten jam nut.

4. With brake (deadman) pedal still depressed, move control handle FORWARD and check for correct adjustment at Stop (E), see Plate 7484. Adjust, if necessary, as outlined in Step 3.

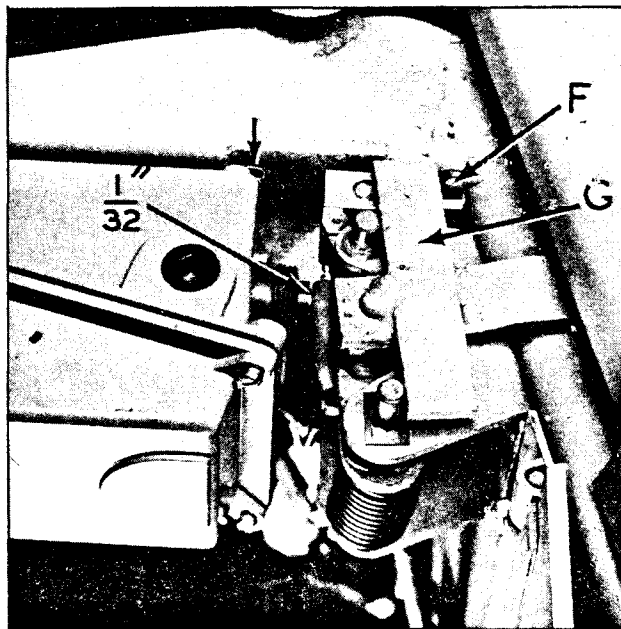

Plate 7486. Neutral Position Switch Arm (F) full up.

5. Switch Arm (F) must fully extend up beyond the actuating lever as shown above and in Plate 7487, on the following page.

If clearance adjustment is necessary, loosen switch mounting screws and move switch in direction necessary, as shown in Plate 7487. The mounting bracket is provided with elongated holes for this adjustment. Tighten mounting screws after correct adjustment is obtained.

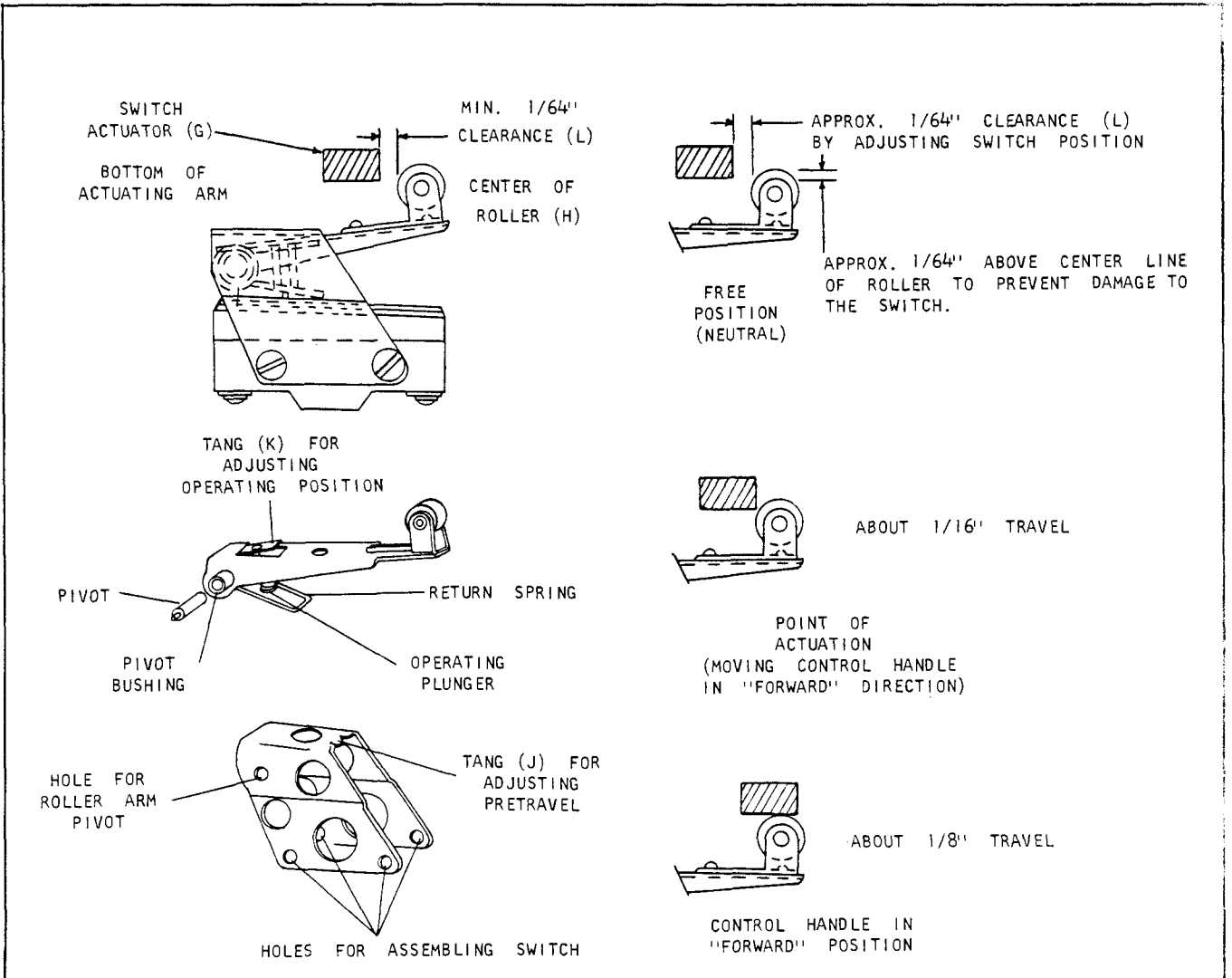

Plate 7487. Directional Switch Adjustment

6. Bottom of the Switch Actuator (G) should be on center line of Switch Roller (H). The actuator should contact switch roller at the center line of roller or slightly above center line (as shown above), actuator must not contact switch roller below center line or damage to switch may result.

If vertical adjustment of roller is necessary, bend TANG (J) downward to lower switch arm & roller or vice versa.

7. Switch should actuate as Actuator (G) contacts and then depresses switch Roller (H).

If adjustment of actuating point of switch is necessary, bend TANG (K), on the switch arm, downward just enough so that switch will actuate approximately 1/16 inch before roller is fully depressed by actuator (G).

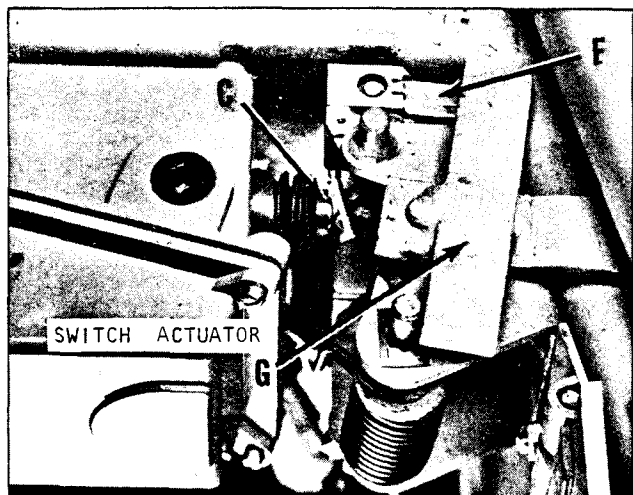

ACCELERATING CONTROL ASSEMBLY, SEE NEXT PAGE

1. Control assembly, accelerating
2. Housing, accel control assy base
3. Cover, accelerating control assembly
4. Gasket, accelerator control assy cover
5. Switch, accelerating control
6. Bus, accelerating control long
7. Bus, accelerating control short
8. Base, accelerating control switch
9. Adjuster, accelerating control switch
10. Yoke assembly, accelerating control sw
11. Spring, accel contr switch operating
12. Retainer, accel contr switch oper spg
13. Spring, accel contr camshaft return
14. Retainer, accel contr camshaft sprg
15. Guide, accel control camshaft spring
16. Arm accel control camshaft
17. Pivot, accel control camshaft arm
18. Fastener, accel control shaft arm pivot
19. Boot, accelerating control camshaft
20. Camshaft, accelerating control
21. Lockout, accelerating contr 4th speed
22. Bearing, accel control camshaft
23. Guide, accel control valve spring
24. Spring, accelerating control valve
25. Piston, accelerating contr dash pot
26. Ring, accel control dash pot piston
27. Seal, accel control piston camshaft
28. Washer, accel contr valve cap seal
29. Valve cap, accelerating control
30. Dash pot assembly, accel control
31. Fastener, accelerating control dash pot
32. Adjuster, accel contr (0 to 2nd) timing
33. Adjuster, A C (3rd to 4th) timing
34. Adjuster, A C (2nd to 3rd) timing
- 35.* Magnet assembly, accel contr plugging
36. Frame assembly, A C magnet outside pole
37. Frame assembly, A C magnet center pole
38. Armature assembly, accel contr magnet
39. Latch, accelerating control magnet
40. Support, accel contr magnet resistor
41. Fastener, accel contr magnet terminal
42. Insulator, accel contr magnet resistor
43. Lead assy, accel contr magnet resistor
44. Resistor, accelerating control magnet
45. Coil, accelerating control magnet
46. Fastener, accelerating control cover
47. Spring, accel control magnet latch
48. Fastener, accelerating control switch
49. Fastener, A C magnet outside frame
50. Fastener, A C magnet center frame
51. Fastener, A C magnet armature
52. Fastener, accel control magnet resistor
53. Fastener, A C magnet resistor terminal
54. Fastener, accel control switch base
55. Fastener, accel control assy

* Item 35, Plugging Magnet -- (item 44) Resistor equipped with SLIDER for adjustment purposes, refer to write-up "PLUGGING CONTROL" for adjustment procedures.

Plate 7488. Control Arm Moved Forward.
Brake (Deadman) Pedal in the DOWN Position.

8. Upon moving the control handle forward, Switch (F) must operate before the I.M.S. switch actuates (located in the switch box). The adjustment may be checked in the following manner:

(a) Depress brake pedal.

(b) Slowly move control handle forward. Directional Switch (F) should actuate first, then the control box I.M.S. switch should actuate. An audible click may be heard as each switch is actuated. If both switches are heard about the same time (or only one click is audible, indicating both switches are operating at the same time), then re-adjust time delay (red screw) for .2 second delay so first the directional switch and then the I.M.S. switch actuates. Refer to the ACCELERATING MASTER CONTROL (SWITCH BOX) ASSEMBLY adjustment procedures listed in the following write-up.

ACCELERATING MASTER CONTROL (SWITCH BOX) ASSEMBLY

The accelerating master switch for truck control is a manually operated pilot device to control magnetic contactors, which in turn, control the traction motor of the truck. It provides four individual speeds and has time delay acceleration and plugging control.

The plugging magnet (item 35), refer to the following page, is polarized correctly for negative battery to armature when the resistor center tap is connected to the upper coil terminal (as viewed on the machine).

CAUTION

THE SCREWS HOLDING THE MAGNETIC CONTROL ASSEMBLY (ITEM 38) SHOULD NEVER BE LOOSENED, AS THIS RENDERS IT TOTALLY INEFFECTIVE.

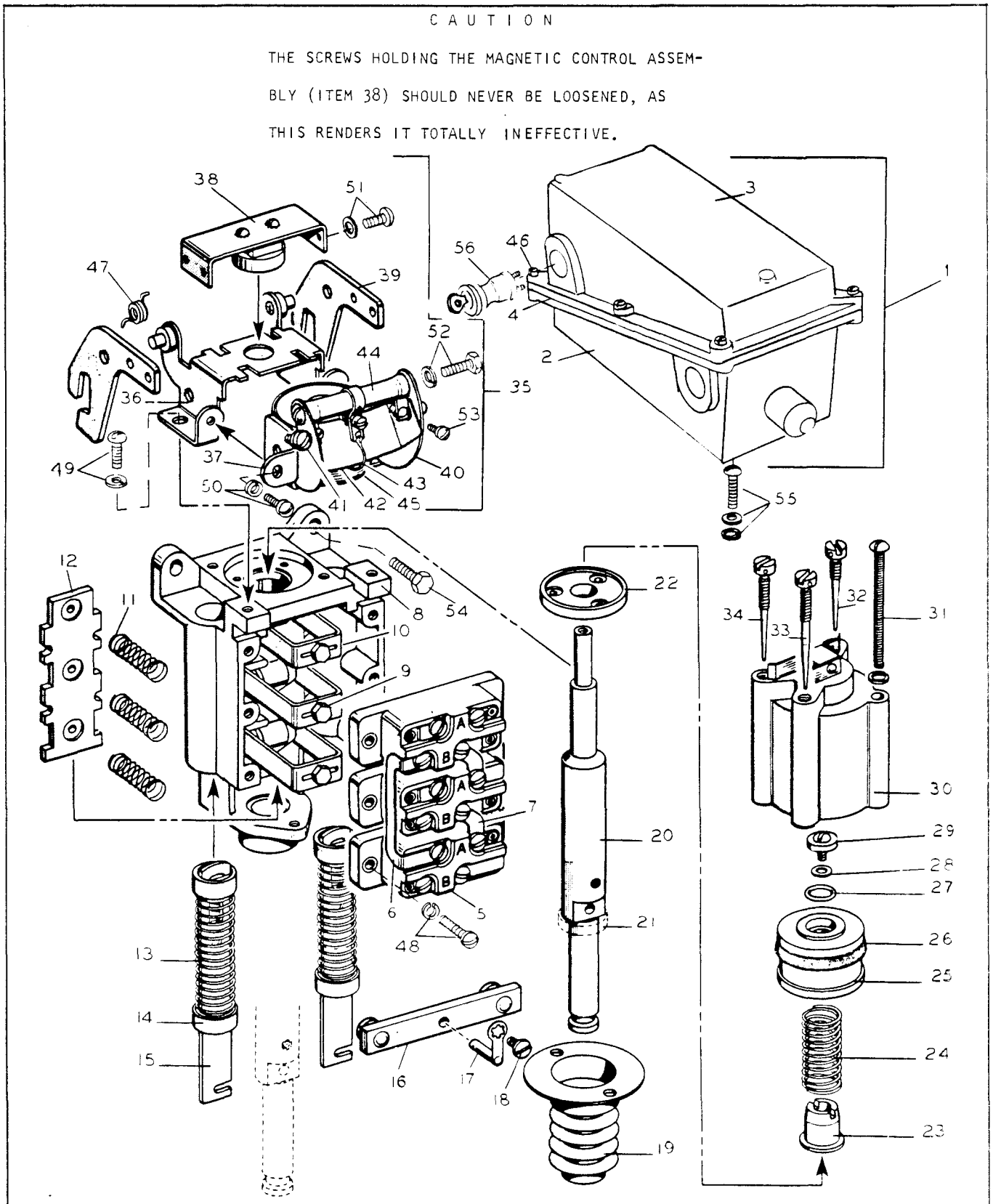

Plate 7499. Typical Accelerating Control Assembly



INDUSTRIAL TRUCK DIVISION



LUBRICATION AND PREVENTIVE MAINTENANCE

ADJUSTMENT OF TRAVEL CONTROL

In either direction, truck should always move on level floor, loaded or empty, at 1 M.P.H. or faster.

Perform following visual checks:

| | Approx. no load speed M.P.H. |
|---|------------------------------|
| 1st Speed: F or R Contactor (on drive unit) closes | 2.5 (adjustable) |
| 2nd Speed: 1-A Contactor (on inner door) closes | 3.3 (adjustable) |
| 3rd Speed: 2-A Contactor (on inner door) closes (2-A Contactor remains closed) | 4.5 |
| 4th Speed: 1-A Contactor opens (2-A Contactor remains closed) | 5.5 |

ADJUSTMENT OF PLUGGING CONTROL

With proper full sized battery in the truck, but with battery at a low state of charge, adjust SLIDING CONTACT on small control resistor DOWNWARD until truck will go into 2nd (and higher) speed positions when truck is blocked so it cannot move. However, excessive DOWNWARD adjustment of the resistor will allow uncontrolled PLUGGING.

Test for this by driving truck in each direction in 3rd or 4th speed and rapidly reversing direction. When properly adjusted, truck should always slow down in 1st speed position and then proceed in the opposite direction with the controls passing through 2nd and higher speed positions.

If truck PLUGS or REVERSES DIRECTION at any speed position other than 1st, this is UNCONTROLLED PLUGGING and it will be necessary to adjust resistor by sliding contact UPWARDS until controlled plugging is achieved.

ADJUSTMENT OF TIME DELAYS:

Adjust colored screws (IN for longer — OUT for shorter time delays) for the following timed periods:

NEUTRAL to 2nd SPEEDS:

* .2 second delay — adjust RED screw (upper screw)

2nd to 3rd SPEEDS

.4 seconds delay --- adjust WHITE screw (lower left screw)

3rd to 4th SPEEDS:

.6 seconds delay — adjust BLACK screw (lower right screw)

*To start up on a grade, it is required that the time delay setting between 1st and 2nd speed be short enough for 2nd speed (and higher) positions to pick-up. Approximately .2 second delay should be adequate for 10% grade. Shorter delay time may be required for steeper grades. The normal anti-plug function will not permit the master control to pick-up 2nd point of power if the truck can roll backwards at any appreciable speed.

Timing of the master control is made with the adjusting screws on the end of the dash pot (item 30), refer to the preceding page. This dash pot is an air escapement device using the air in front of the piston to flow through an orifice to reach the rear side of the piston.



INDUSTRIAL TRUCK DIVISION



LUBRICATION AND PREVENTIVE MAINTENANCE

Ports are arranged with controlling adjustments to control the timing between 1st and 2nd, 2nd and 3rd, and 3rd and 4th. These are found in order starting at right rear of switch and proceeding counterclockwise (as viewed in the vertical position shown on the preceding page. The RED adjusting screw controls the timing before reaching 2nd speed. This is set to provide sufficient time for the directional contactor to close, and establish its holding circuit before the switch reaches 2nd speed. It is recommended that this screw be left as shipped from the factory. The WHITE adjusting screw is for the time between 2nd and 3rd speeds, and the BLACK adjusting screw is for the timing between 3rd and 4th speeds. Speeds are factory set and should be adequate for average applications without further adjusting.

MAINTENANCE (Refer to the preceding page)

The cam operated control switch (item 5) may be replaced when necessary simply by removing connectors (items 6 & 7) and the mounting screws (items 48). DO NOT CHANGE THE SETTING OF THE ADJUSTING SCREWS (ITEM 9). If it becomes necessary to replace the roller arm and yoke assembly (item 10) only then should an adjustment be made at screw (item 9). This setting should be .056 inches measured from the top of the adjusting screw to the mounting surfaces of the control switch with the operating shaft (item 20) fully extended.

If fine filings or foreign materials are found on the pole faces of the plugging magnet (item 35), they should be removed with an air hose to insure consistent operation.

The two operating shaft bearings (item 22) are "Oilite" bushings and require no further lubrication. The piston ring (item 26) is a graphite impregnated synthetic rubber material that is self lubricating and requires no additional lubrication of any kind.

If an increase in timing between speeds occurs, it may be an indication that dash pot and piston require cleaning (item 30). Remove dash pot and 3 colored adjusting screws from dash pot. (NOTE THAT SCREWS ARE OF DIFFERENT LENGTHS AND MUST BE REASSEMBLED IN THEIR RESPECTIVE HOLES.) Wash dash pot thoroughly in a Stoddard type cleaning solvent and blow out adjusting screw holes with air hose. Wipe piston (item 25), piston ring (item 26), adjusting screws (items 32, 33 & 34) with solvent dampened cloth. Reassemble and adjust screws to give desired timed acceleration (refer to adjustment paragraph).

REFER TO
TROUBLE SHOOTING
GUIDE

IF 1st AND 2nd SPEEDS SEEM
VERY LOW, CHECK CONNECTION
TO MAIN RESISTORS FOR AGREE-
MENT WITH THE WIRING DIAGRAM.

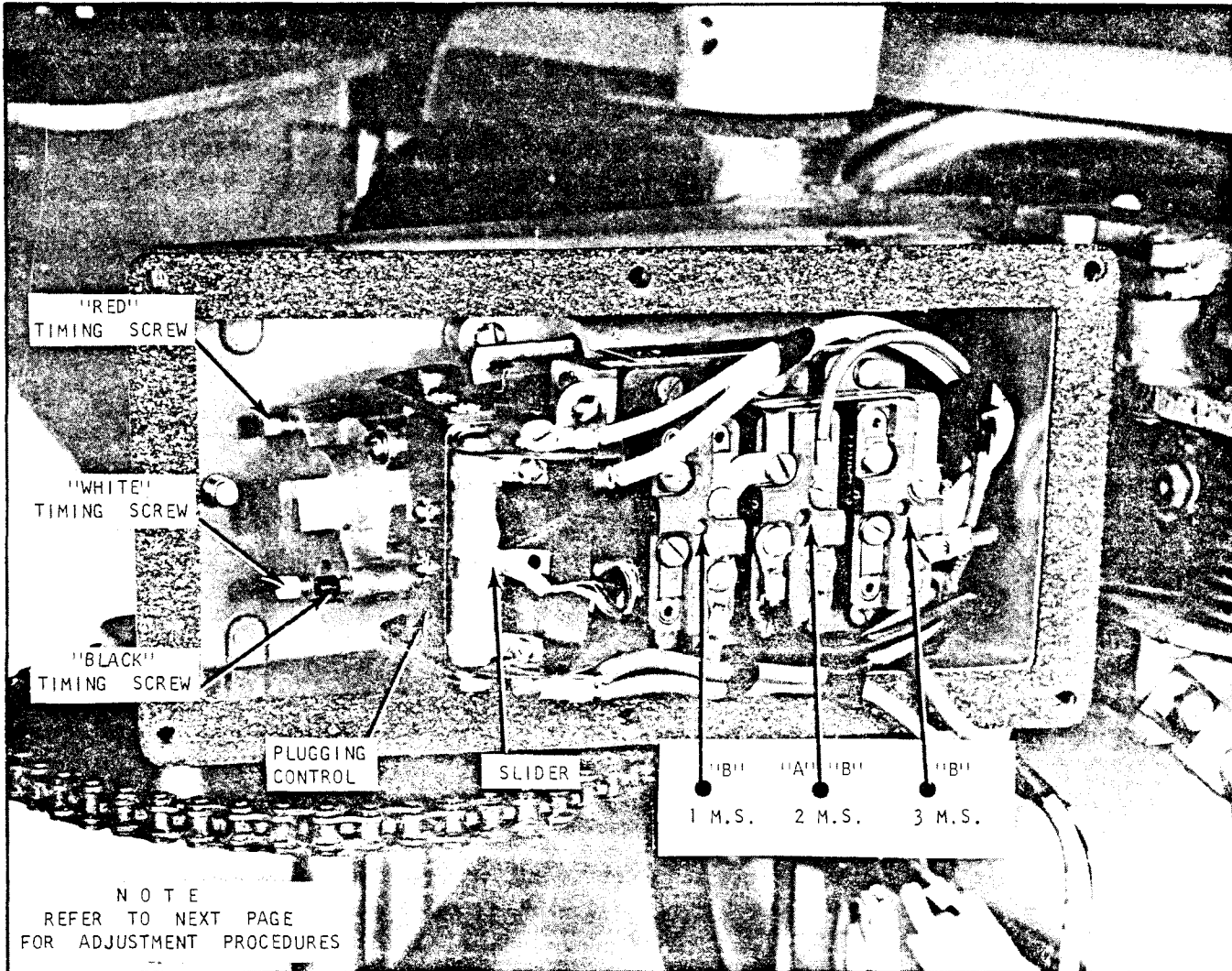

Plate 7500. Accelerating Master Control (Switch) Box

NOTE

- | | |
|--------------|-------------------|
| 1 M.S. - "B" | (normally open) |
| 2 M.S. - "A" | (normally open) |
| 2 M.S. - "B" | (normally closed) |
| 3 M.S. - "B" | (normally open) |

ACCELERATING
SWITCH OPERATING SEQUENCE

ACTUATING CONTROL HANDLE FORWARD:

- 1 M.S. - "B" closes, Forward Contactor actuates completing circuit to the Drive Motor.
- 2 M.S. - "A" closes, and 2 M.S. - "B" opens; 1-A Contactor actuates — 2nd Point of Power, or 1st Acceleration.
- 3 M.S. - "B" closes, 2-A Contactor closes (bypasses all resistors) — 3rd Point of Power, or 3rd Speed.
- 2 M.S. - "B" Closes, and 2 M.S. - "A" opens; 1-A Contactor opens — 4th Point of Power, or 4th Speed.

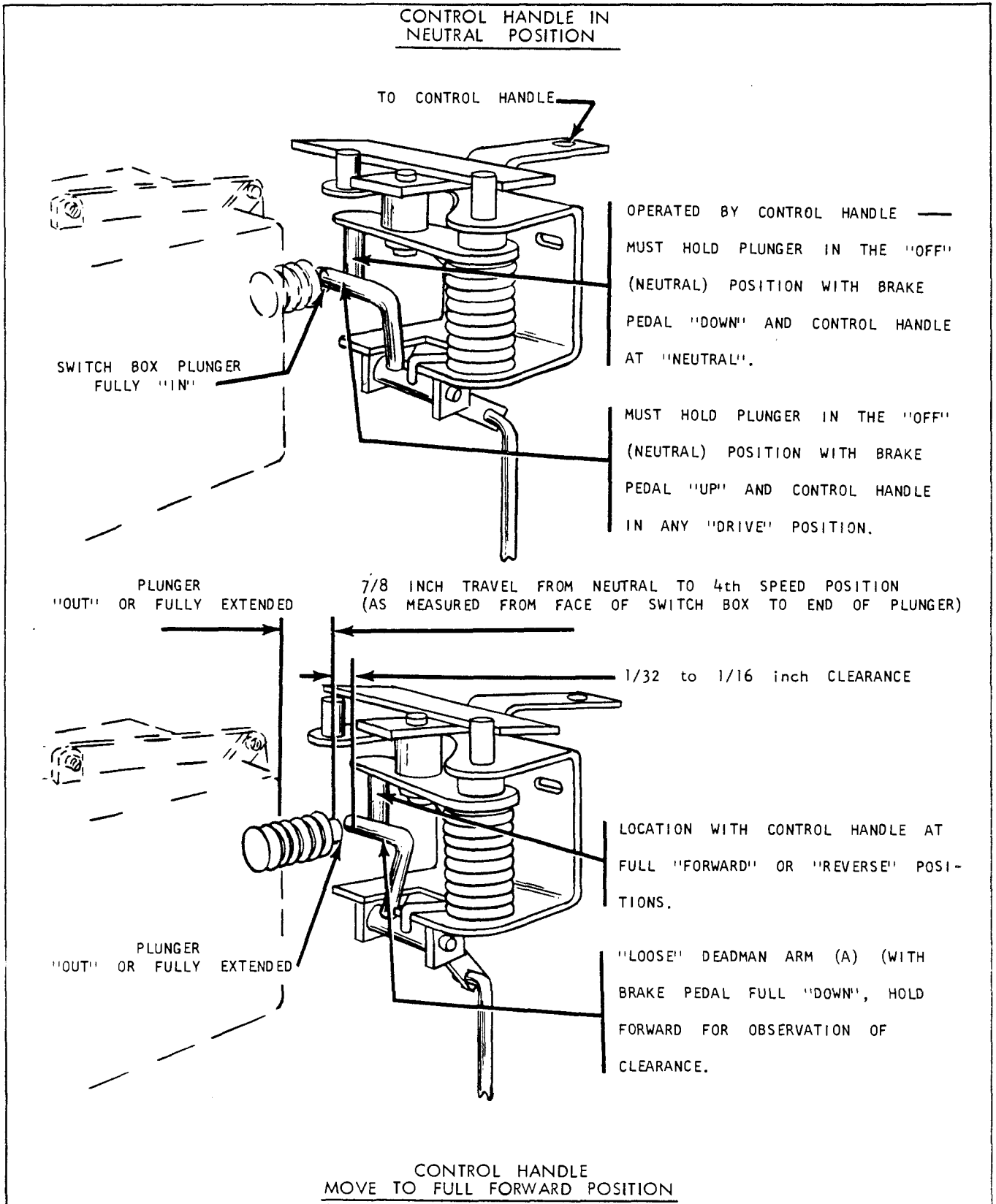

Plate 7501. Drive Control Adjustment

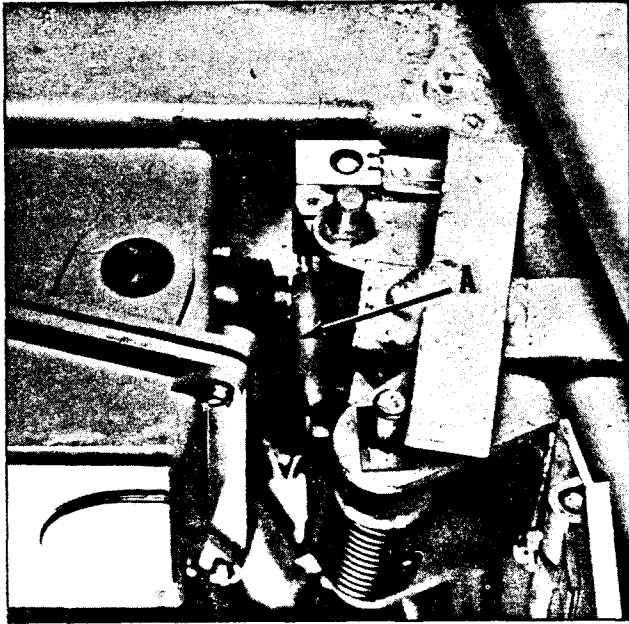

Plate 7502. Combination Drive and Brake Control Rod Spring Adjustment

DRIVE CONTROLS (LOWER PORTION)

Combination Brake and Drive Control Adjustment Check

1. With power key switch off, fully depress brake pedal.
2. Move drive control handle to full forward position.
3. Check for correct adjustment of the switch box plunger as follows:

(a) With brake pedal in the down position, there should be approximately 1/32 to 1/16 inch clearance between Deadman Arm (item A), see Plate 7501, and switch box plunger.

(b) With brake pedal in the DOWN position and drive control handle all the way FORWARD, slowly release brake pedal. Deadman Rods (4 & 5), see Plate 7501 and 8277, should actuate Deadman Arm (item A) which returns switch box plunger to the OFF or RETRACTION POSITION shown in the above plate.

If any of the previous adjustment checks are found to be incorrect, make adjustments per the following procedure.

Adjustment

1. Remove battery from machine.
2. Depress brake pedal and hold.
3. The Off-Set Arm (1), see Plates 8265, 8266, 7505, should be adjusted 7/16 of an inch below top of battery roller. This distance is measured from the bottom of the off-set arm to the top of the battery roller.

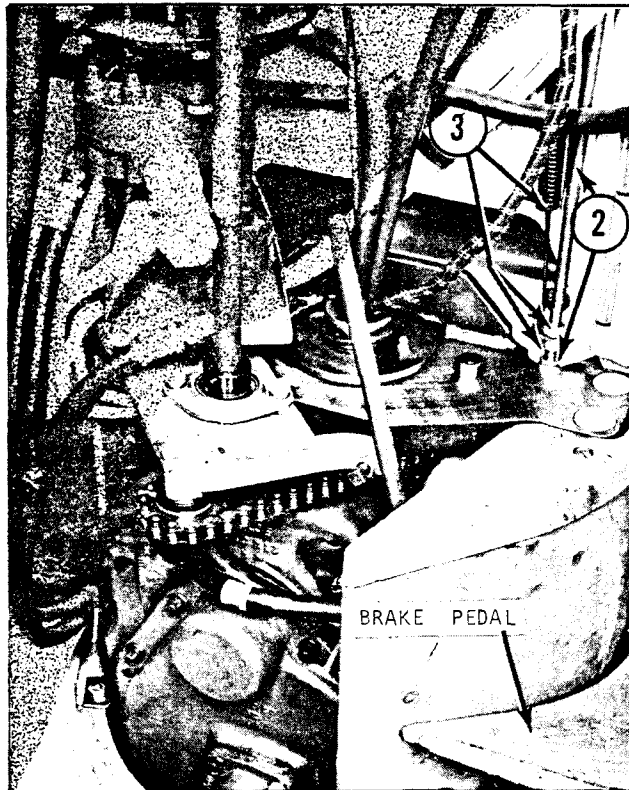

Plate 8265 Deadman Rod Adjustment (as viewed from rear of machine — both rear doors open)

The off-set arm adjustment is necessary so the arm will miss the contactor box (located on the drive unit) and, so it will not contact the battery when the brake pedal is in the UP position.

4. If necessary, loosen Jam Nuts (1), see Plate 7505, and rotate nuts in the direction necessary to obtain correct adjustment.

Check adjustment. With pedal down, rotate hand wheel until contactor box is beneath Arm (1). If the two components come in contact with one another, correct the adjustment. However, be sure the arm is not adjusted too high. Arm must not contact battery with pedal in the UP position. Therefore, the 7/16 inch dimension must be held.

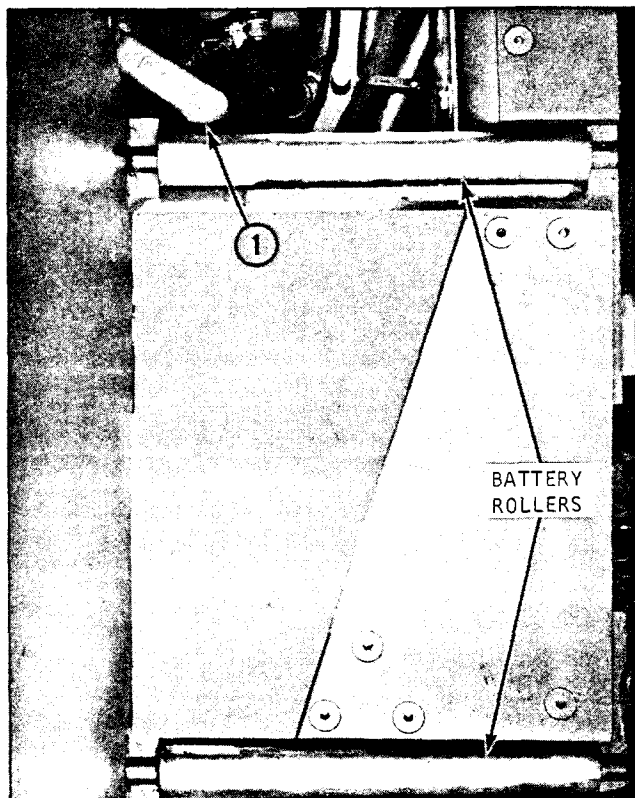

Plate 8266. Off-Set Arm Adjustment
(With Brake Pedal DOWN, off-set arm MUST NOT TOUCH drive unit contactor box — with brake pedal UP, off-set arm MUST NOT come in contact with battery.)
(viewed from battery compartment)

5. Tighten Jam Nuts (1) after obtaining correct adjustment.

If the off-set arm requires adjustment, it will be necessary to re-adjust Deadman Rods (4 & 5) as follows:

1. With brake pedal fully depressed and held in this position, move drive control handle all the way forward and hold.

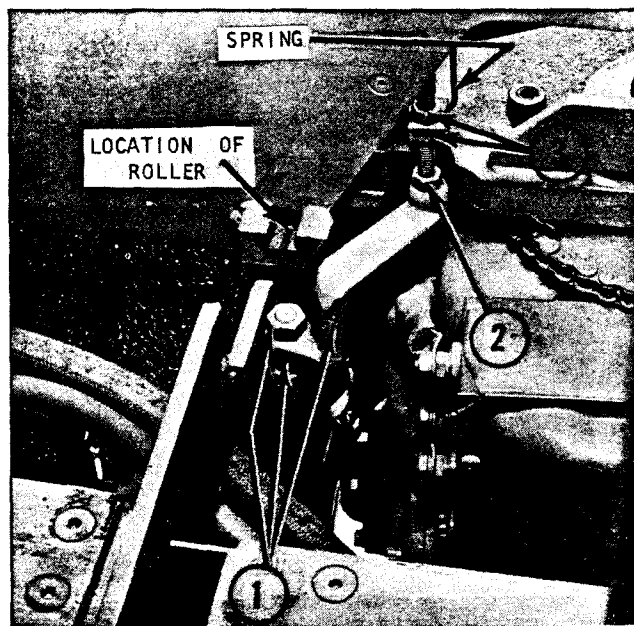

Plate 7505. Off-Set Arm Adjustment (item 1)
Deadman Rod Adjustment (item 2)
Pedal Spring Adjustment (item 3)

2. Loosen Jam Nut (2), see Plates 8265 and 7505, and adjust Rod (4), see Plate 8277 on the next page, to come in contact with Rod (5).

NOTE: Deadman Arm (A) should be held by hand (in the position shown in Plate 7501) while adjusting Lower Rod (4) to come in contact with Upper Rod (5). Using this method, the mechanic may feel Rod (4) contact Rod (5) as Deadman Arm (A) will start to move away from the "held" position when correct adjustment is obtained. After completing adjustment, tighten Jam Nut (2).

3. With drive control handle held in the full forward position, slowly release brake pedal. Deadman Arm (A) should return the switch box plunger to the OFF or RETRACTED POSITION shown in Plate 7502, refer to the preceding page.

If adjustment is necessary, loosen Jam Nuts (3), see Plate 8265 on preceding page, and adjust to increase pedal spring tension. After satisfactory adjustment is obtained, tighten jam nuts.

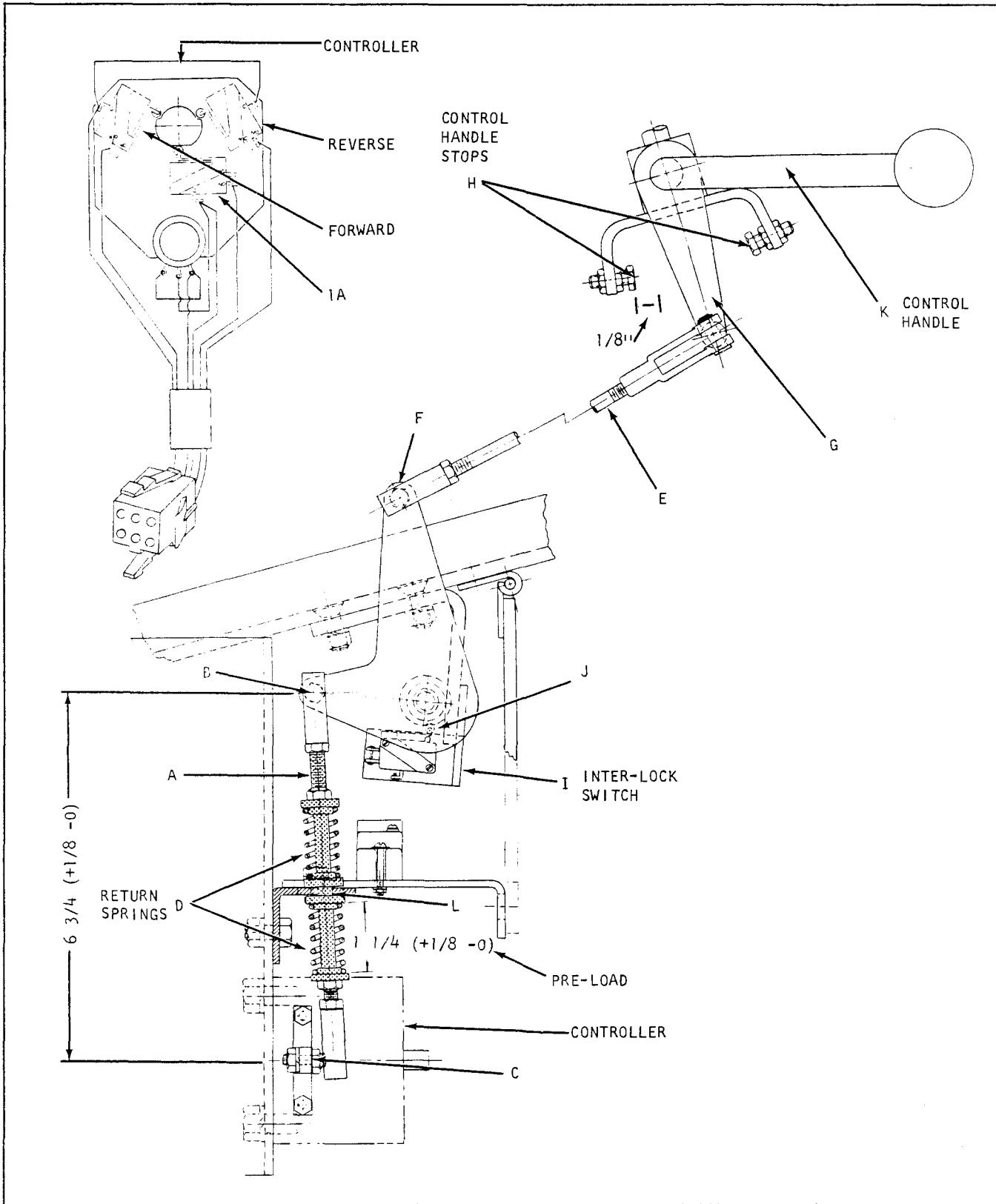

Plate 9447. Typical Upper Drive Controls

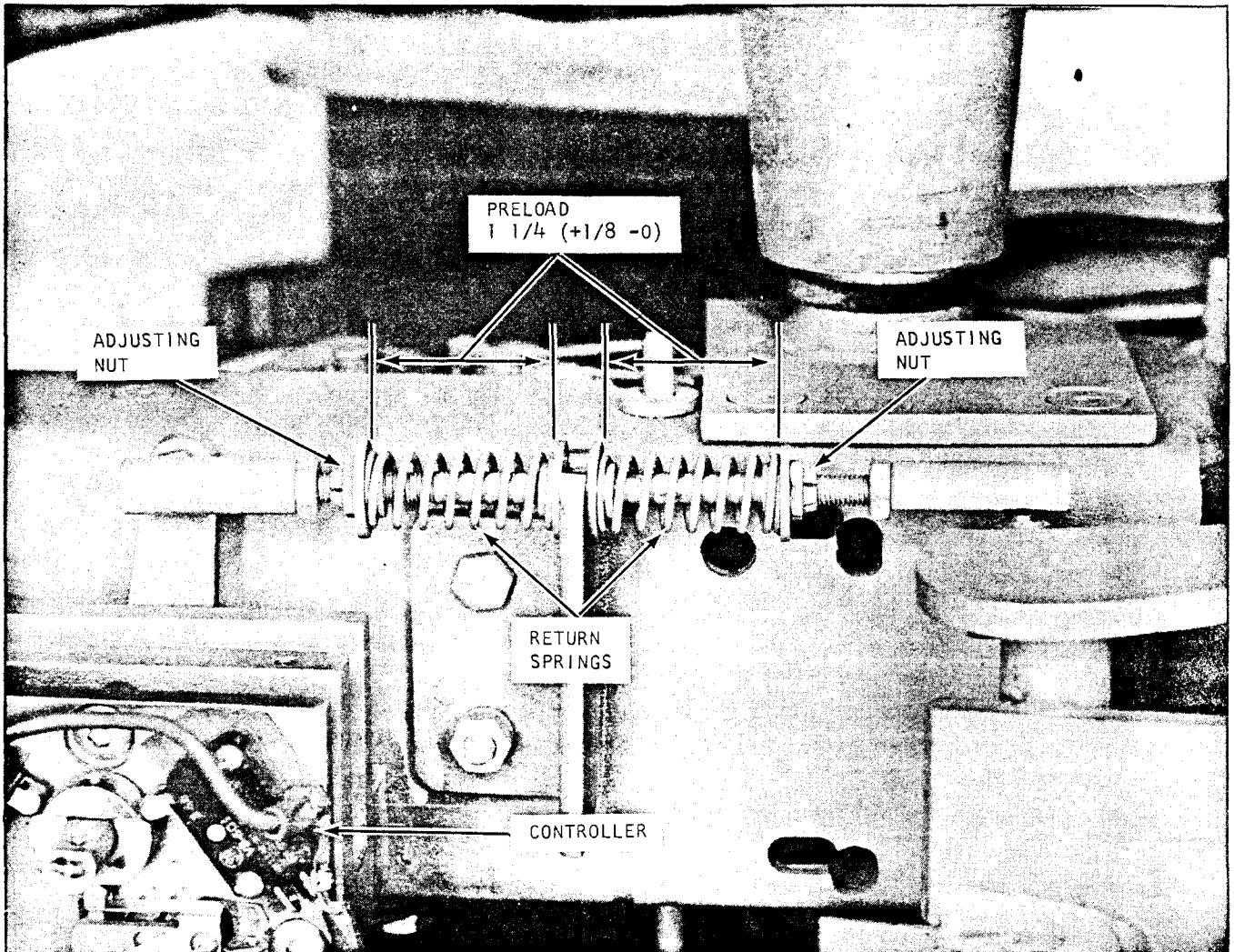

Plate 9448. Typical Return Springs

DRIVE CONTROL LINKAGE ADJUSTMENTS (Plate 9447)

N O T E

Objective: To adjust drive control linkage to controller in such a manner that: all switches operate in their proper sequence, there is no rubbing of linkage rod against bracket slot, and control handle arm is midway between stop brackets. All dimensions referred to in this write-up are for initial adjustment. Should any of the dimensions here-in give the wrong results on your machine, then the dimension should be changed to suit the particular condition.

Some controller arms are adjustable by loosening the setscrew. Some are not adjustable due to the detent in the controller shaft. In this latter case, disregard adjusting.

1. Disconnect rod "A" from bellcrank at position "B" and rod "E" from bellcrank at position "F".
2. Check controller arm "C" to make sure it is in a vertical position when controller is in neutral.

3. Adjust rod "A" to measure $6 \frac{3}{4} (+ \frac{1}{8}-0)$ " and attach to bellcrank "B".

4. Adjust springs "D" to measure $1 \frac{1}{4} (+ \frac{1}{8}-0)$ " each.

5. Rotate bellcrank in both directions, watching to see if there is any rubbing action (at extreme ends of travel) in bracket slot "L". If not, go to step 6. If so, adjust as follows: If the rod rubs slot "L" while being turned clockwise, then the rod must be shortened. If the rod rubs slot "L" while being turned counter-clockwise then rod "A" must be

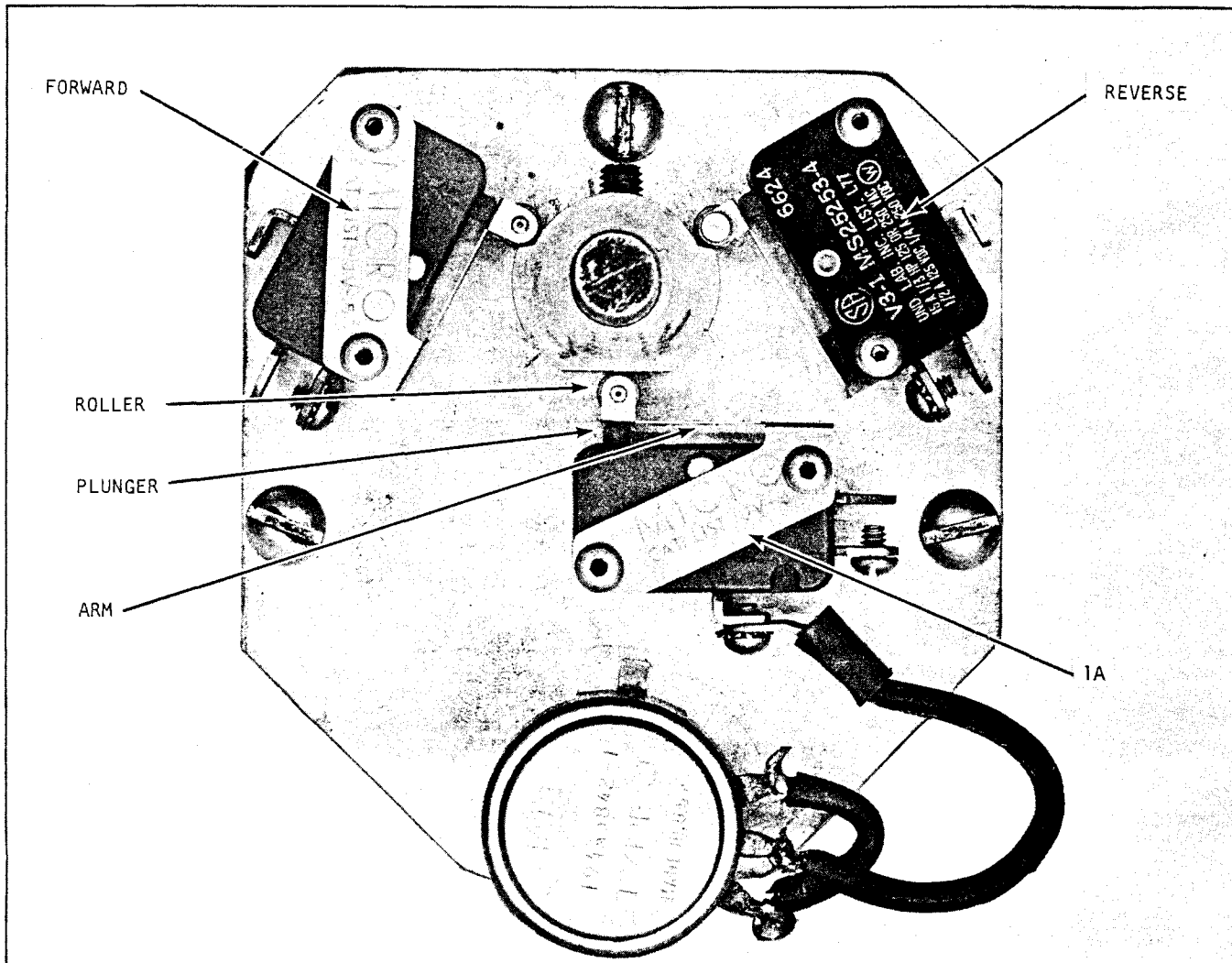

Plate 9492. Typical SCR Controller

lengthened. Continue this procedure until no rubbing action is noted.

6. Now check to see if the bottom (flat) part of the controller cam is horizontal and adjust if necessary.

7. Refer to plate 9492 and determine if switches are adjusted to the cam as shown and here described: The forward and reverse switch rollers must be just setting in their respective detents so that the arm of the switch just touches the switch plunger. Next determine that the 1A switch roller is positioned midway of the bottom surface (machined from the cam) and that the arm is also just touching its plunger.

If the switches are not adjusted properly, then adjust as follows:

NOTE

Switches are mounted to a Tapping plate. Mounting screws pass thru oversized holes in the bracket to a tapping plate. (See plate 9493.)

(a) Loosen the screws on one of the switches that is out of adjustment just enough so switch is moveable (being careful not to over-loosen because backing plate would then fall off).

(b) Position switch as described previously and tighten screws while holding switch in this position.

(c) Follow this same procedure with any other switches not adjusted properly.

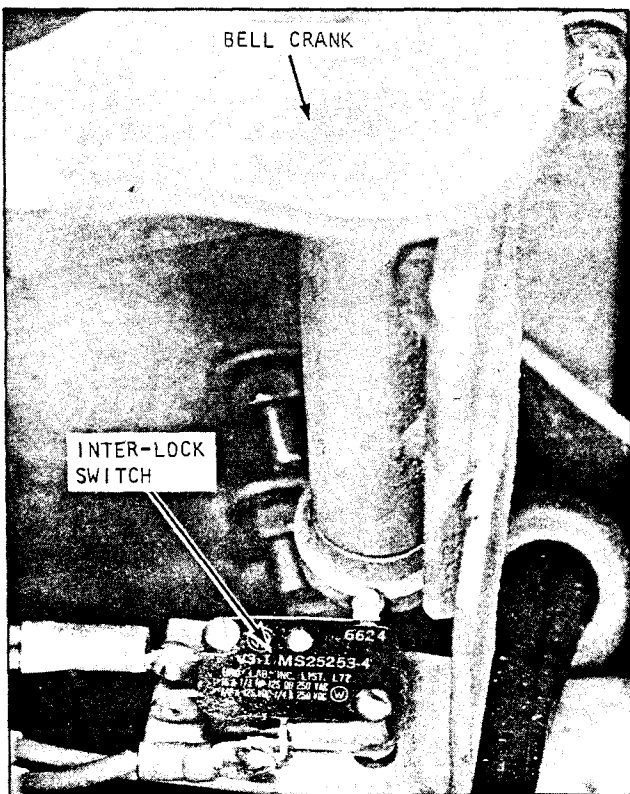

Plate 9449. Typical Interlock Switch

8. Attach rod "E" at bellcrank position "F" and arm "G" so that arm "G" is midway between stop brackets.
9. Adjust interlock switch so that it actuates before forward or reverse switches.
10. Move control handle forward until IA switch actuates, hold, and adjust right hand stop 1/8" from arm "G". Do the reverse of this for the remaining stop.

REVIEW CHECK

If everything is adjusted properly, the following conditions should be present:

1. With control handle in neutral all switch rollers (F, R, IA, interlock) should be in their proper positions (detents).
2. Control handle arm "G" should be midway between its stops "H".
3. When control handle is moved forward the first "click" should be in the interlock switch actuating, the second "click" should be the F switch actuating and the third "click" should be the IA switch actuating.

4. When the control handle is moved in reverse the first "click" should be the interlock switch actuating, the second "click" should be the R switch actuating and the third "click" should be the IA switch actuating.

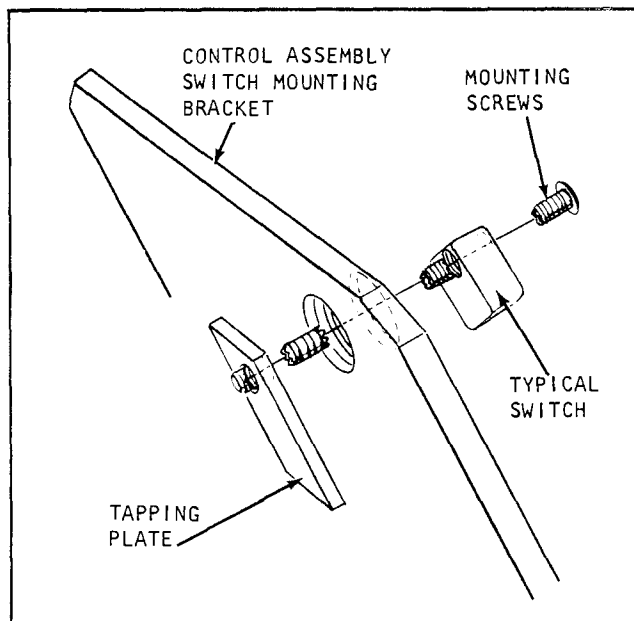

Plate 9493. Typical Controller Switch Mount

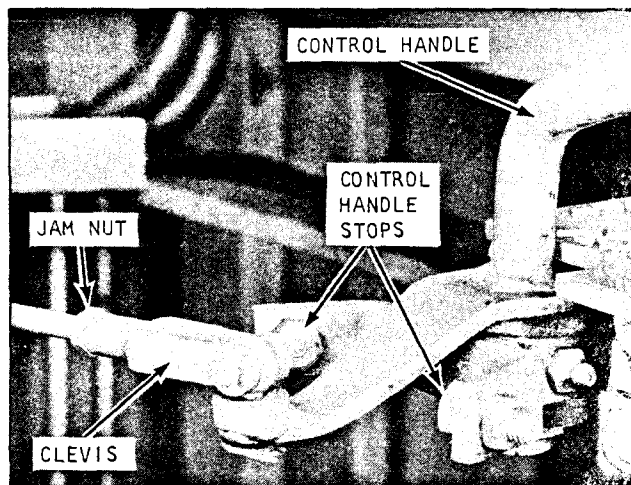

Plate 9450. Typical Control Handle Stops

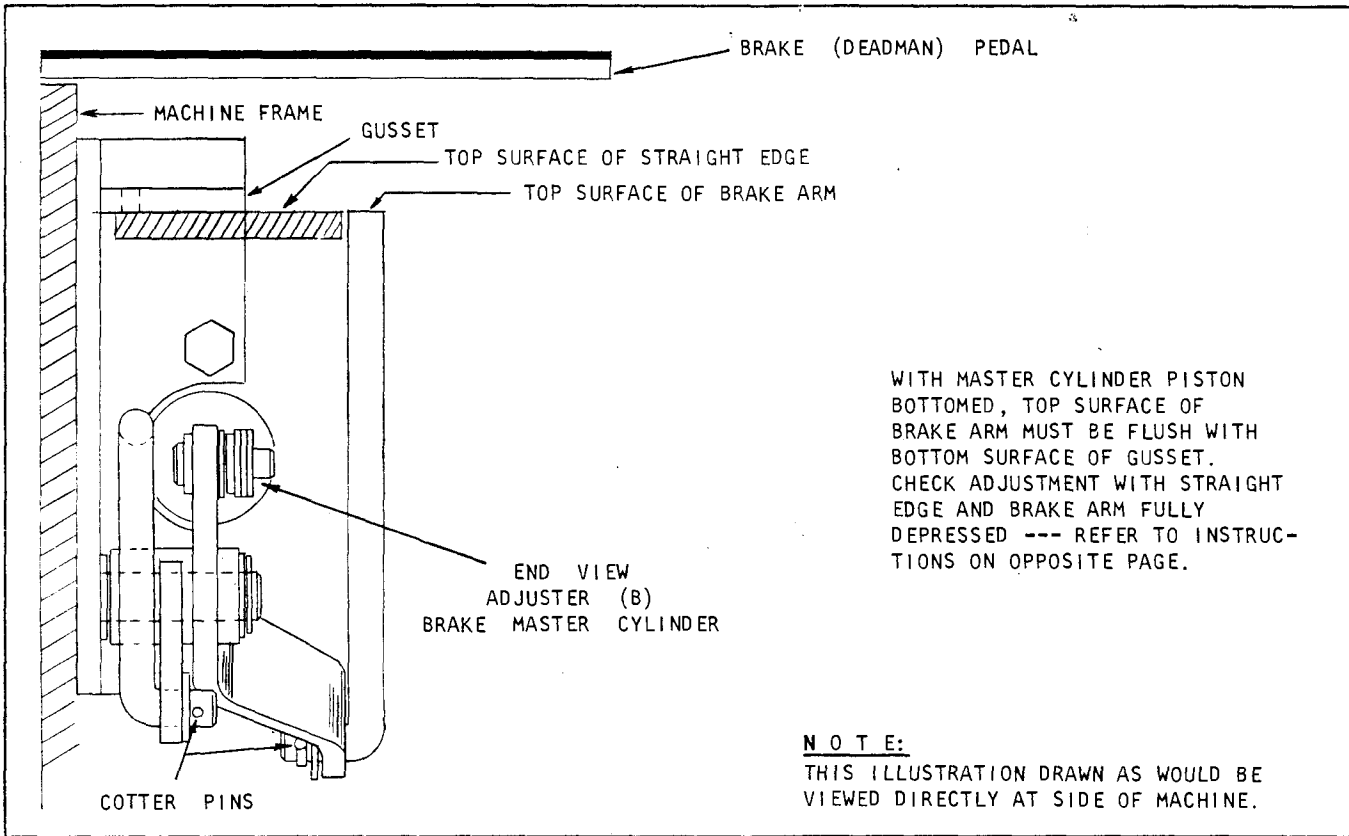

Plate 8267 Brake (Deadman) Pedal Arm (fully depressed)

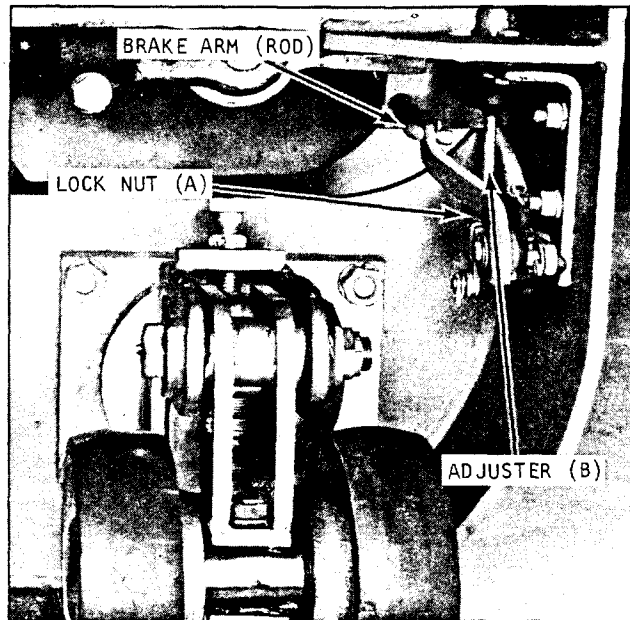

Plate 8268. Brake Cylinder, Pivot Arm and Pedal Rod Adjustment

BRAKE PEDAL LINKAGE ADJUSTMENT

NOTE: The brake pedal (when fully depressed) MUST rest on the machine frame and not on the brake linkage. In other words, the brake arm must not support the brake pedal with the pedal in the down position. If such a condition should exist, this means that the master cylinder piston has bottomed and the piston and brake arm are the full support of the machine operator when standing on the brake pedal. Such a condition causes excessive strain on the master cylinder and linkage and could very well cause damage to these components. On the other hand, the linkage must not be adjusted for too short a piston stroke.

1. Remove hair pin cotter connecting brake arm to brake pedal. Remove brake pedal from machine by rotating hinge pin from its self locking down position to the up position. This hinge pin is located at the front or pivot end of the brake pedal. With pin in the up (unlocked) position, move pin to the left releasing pin from the right side of the frame — move pedal to the right and remove from machine.

2. Clean dirt from around the filler cap of the master cylinder reservoir and unscrew cap. Brake fluid should be within 1/4 inch of the top — replenish with S.A.E. 70R3 hydraulic brake fluid (Clark Part No. 1800200) and replace cap. NOTE: Check cap vent hole for obstruction. Vent hole must be open at all

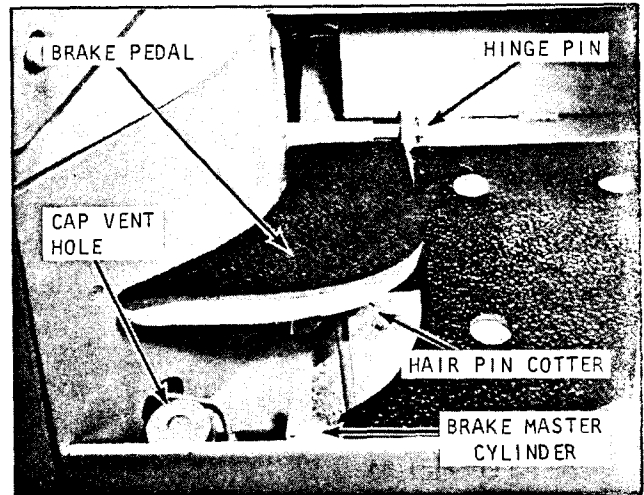

Plate 8264. Brake Pedal

times — clean if needed.

3. Place a straight edge (flat) under gusset (D), see Plate 8267 on preceding page. Depress brake arm downward as far as it will go.

4. Loosen lock nut (A), see Plate 8268 on preceding page. Rotate adjuster (B) until the top surface of the brake arm is flush with the upper surface of the straight edge, see Plate 8267.

5. Tighten lock nut (A) and check adjustment as explained above. Repeat adjustment procedure until correct adjustment is obtained, then replace brake pedal. Connect brake rod to brake pedal with hair pin cotter.

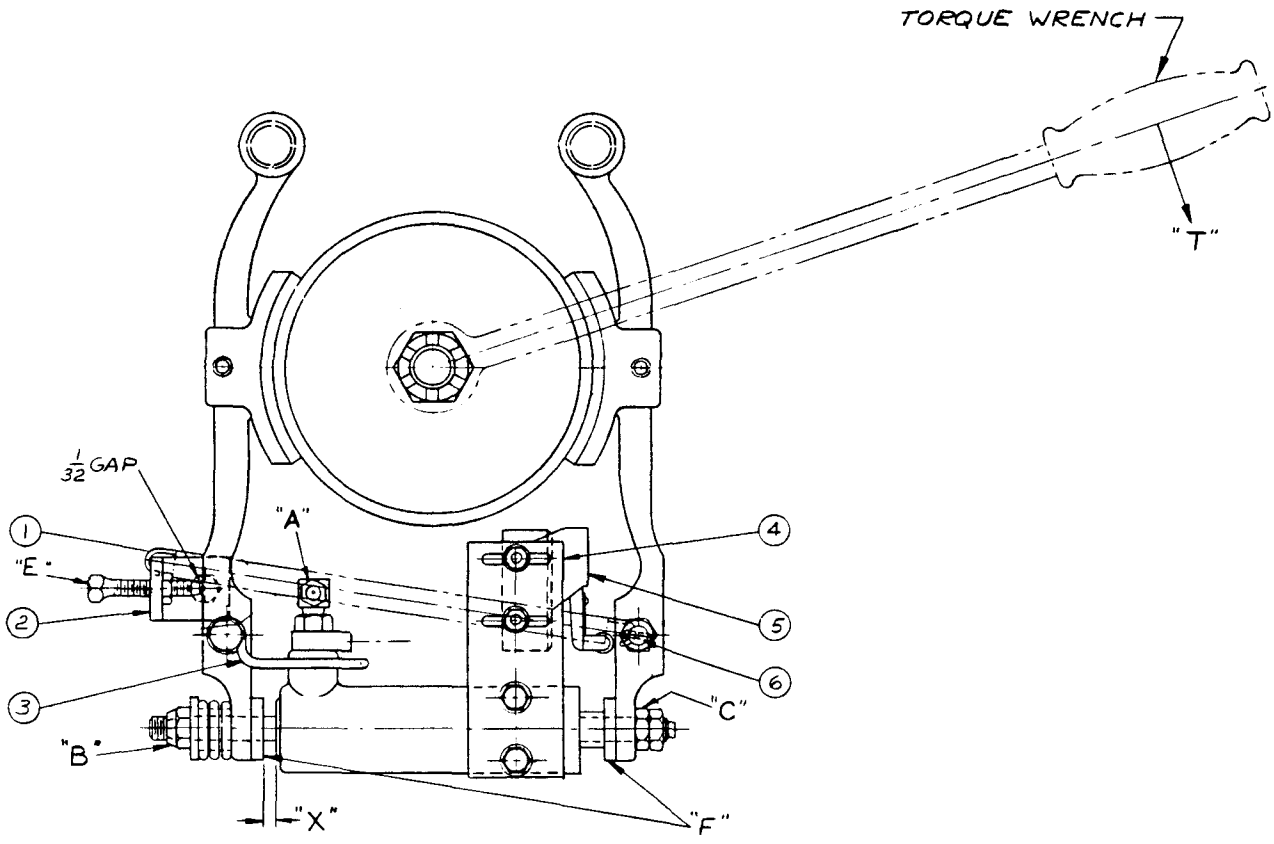

"T" = CALCULATED TORQUES BASED ON MIN. REQUIREMENTS OF HOLDING TRUCK ON 15% GRADE

TABLE "D"

| MODEL | WEIGHT LOADED | "T" - POUND/INCHES | |
|--------|------------------|--------------------|------|
| | | 18.36-1 | 22-1 |
| NST 15 | 6300 | 235 | 200 |
| NST 20 | 7300 | 275 | 230 |
| NST 25 | 8200 | 320 | 265 |
| NST 30 | 8900 | 350 | 290 |
| NST 40 | 10500 | 400 | 325 |



INDUSTRIAL TRUCK DIVISION



LUBRICATION AND PREVENTIVE MAINTENANCE

SERVICE — PARKING BRAKE

Braking is accomplished with the use of a brake drum directly connected to the drive motor shaft. Two brake shoes with bonded linings are connected to two brake shoe arms. The spring supplies the braking force applied on the brake shoe linings to the brake drum — hence the brake is a spring applied unit which is always set until the driver steps on the brake pedal. Stepping on brake pedal actuates a brake cylinder thru linkage which pushes the brake shoe arms or brake linings away from the brake drum thus releasing brake.

- TO ADJUST BRAKE -

1. Loosen Bleeder Screw (A) and bleed out all air (CAUTION - KEEP BRAKE FLUID OFF DRUM AND SHOES). Refer to page 1000H 912 for brake bleeding procedure.
2. Adjust for gradual brake application by adjusting Gap (X) to 3/16" with Nut (B). (NOTE: - NUT (C) TO BE SUFFICIENTLY TIGHT SO BUSHING INSIDE OF SPRING WILL NOT PULL AWAY FROM BRAKE ARM.)
3. Adjust brake holding torque by raising drive tire from floor and adjusting Nut (C) until torque wrench reads correct rating, refer to Table (D), without drum slipping.

X
 X
 X W A R N I N G X
 X
 X AFTER RAISING MACHINE AND BEFORE MAKING X
 X ANY ADJUSTMENTS, ADJUSTMENT CHECKS OR BE- X
 X FORE PERFORMING ANY MAINTENANCE, PLACE X
 X ADEQUATE BLOCKING (SUFFICIENT TO SUPPORT X
 X THE MACHINE) UNDER THE FRAME TO PREVENT X
 X ACCIDENTAL LOWERING OR FALLING OF THE X
 X VEHICLE, THUS PREVENTING PERSONAL IN- X
 X JURY TO MECHANIC OR BYSTANDERS. X
 X

4. Adjust L.H. Brake Arm Stop (E) for approximately 1/32" gap. Loosen jam nut and rotate screw stop. as necessary, tighten jam nut.
5. Adjust brake switch to open before R.H. brake shoe touches drum.

As driver releases brake pedal from the down position, switch should contact brake arm and actuate just before the brake shoe (located on the switch side) contacts the brake drum.

Adjustment is made at the switch mounting bracket. Switch bracket is provided with elongated holes. Loosen nuts and move switch as necessary to obtain correct adjustment. Then tighten nuts securely.

- TO ADJUST FOR LINING WEAR -

6. Repeat Steps 1 thru 5; when wear becomes too great for this adjustment, move Spacers (F) to outside of brake arms — then repeat Steps 1 thru 5.

BRAKE LINING REPLACEMENT

1. Remove spring adjusting nut, washer and spring, freeing brake arm from cylinder.
2. Remove retainer nuts freeing brake arm from cylinder.
3. Remove shoulder bolts allowing brake arms to be removed from brake assembly.
4. Remove roll pins from brake shoes and arms. The roll pins may be tapped free with a suitable punch and mallet.
5. When replacing lining assemblies, purchase brake shoe part number 302658 which will contain the bonded brake lining.

C A U T I O N

IT WILL BE NECESSARY TO ADJUST THE BRAKE AFTER LINING REPLACEMENT.

If the roll pins are not useable after removal, be sure to replace the old pins with new. Pin part number 654619.

After installing components, adjust the brake and check the switch adjustment.

LIFT AND TILT CYLINDERS

Check for drift, leakage at packings, damage and security of mountings. (Anchor pivot pins, flanges and mounting rings.)

LIFT CHAINS

The lift chains are mounted to the chain anchors on the lift carriage and at the chain anchor rods near the lift cylinder piston head.

If it becomes necessary to adjust the lift chains, proceed as follows:

X
X
X W A R N I N G X
X
X KEEP CLEAR OF LOAD AND CARRIAGE WHEN X
X
X MAKING ADJUSTMENTS TO AVOID INJURY IF X
X
X ANY MALFUNCTION SHOULD OCCUR AND CAUSE X
X
X LOAD OR CARRIAGE TO FALL. X
X
X X

1. Elevate carriage to about 4 feet.
2. Smear grease on the innerslide channel as shown in Plate 8622.
3. Pick up a capacity load.

N O T E

It is important that the chain adjustment be made with a capacity load. In this manner you will allow for chain stretch.

4. Making sure upright is either vertical or aft of vertical, lower load to the bottom.
5. Remove capacity load.
6. Raise carriage and measure the distance from where the center of the bottom carriage roller stopped, to the bottom edge of the inner slide. Distance must not be less than 1/2".

LUBRICATE MACHINE

Lubricate all miscellaneous linkage with SAE 20 oil and all grease fittings with chassis grease. (Refer to Lubrication Chart.)

C A U T I O N

WHEN LUBRICATING MACHINE INSPECT FOR LEAKING HYDRAULIC LINES, FITTINGS, AND ELECTRICAL WIRING.

HYDRAULIC CONTROL VALVE AND LINES

Inspect for damage, leakage and security of mounting.

LIFT BRACKET

Inspect for damage, bent forks, etc.

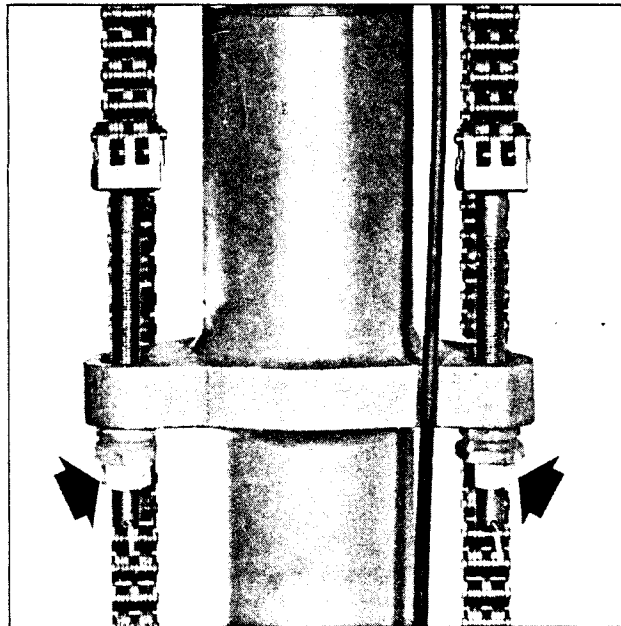

Plate 6634. Lift Chain Adjustment (Chain Anchor Rods)

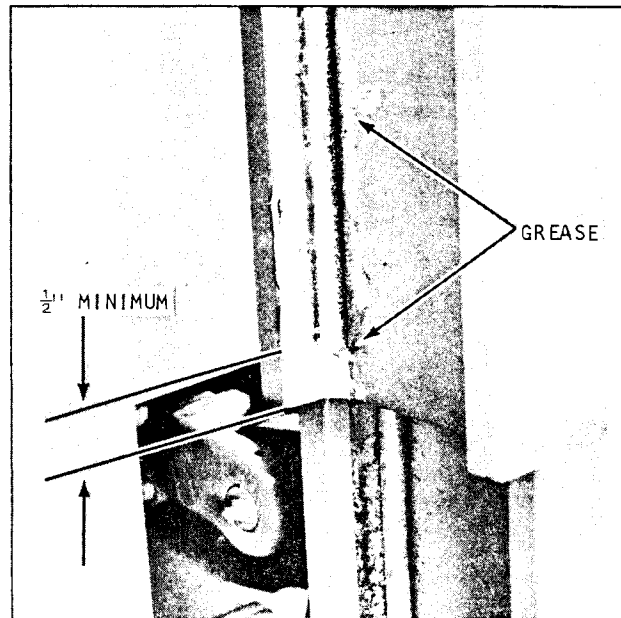

Plate 8622. Lift Chain Adjustment

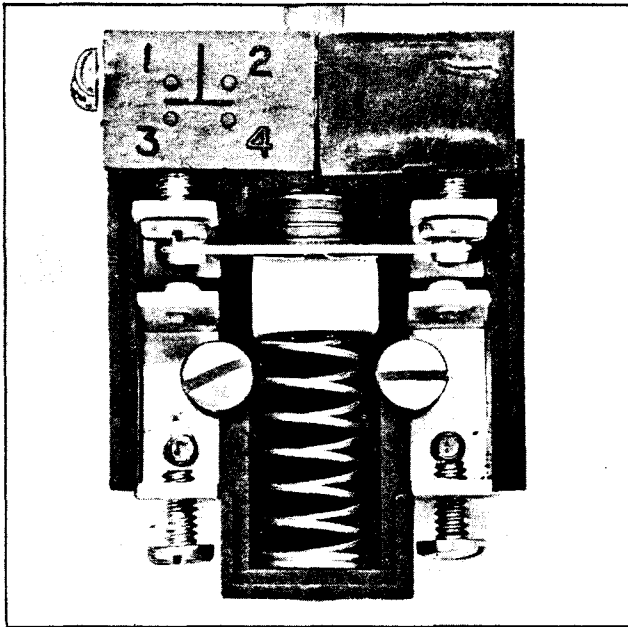

Plate 7443. Typical Pump Control Switch

PUMP CONTROL SWITCHES

The pump control switches are mounted at the valve spool end covers and are activated by movement of the valve spool.

SWITCH ADJUSTMENT

1. Loosen the two screws clamping switch to valve.

2. Position switch on spool end cover so that movable switch contacts are centered between stationary contacts. (Switch contacts are viewed thru clear plastic cover on switch.)

NOTE

ADJUSTMENT OF SWITCHES MUST BE MADE WITH VALVE SPOOL IN NEUTRAL POSITION.

3. After correct adjustment is obtained tighten switch clamping screws.

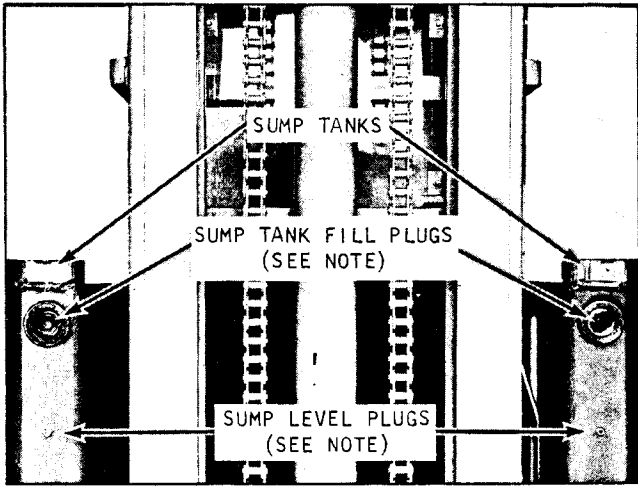

Plate 7528. Location of (Breather) Filter

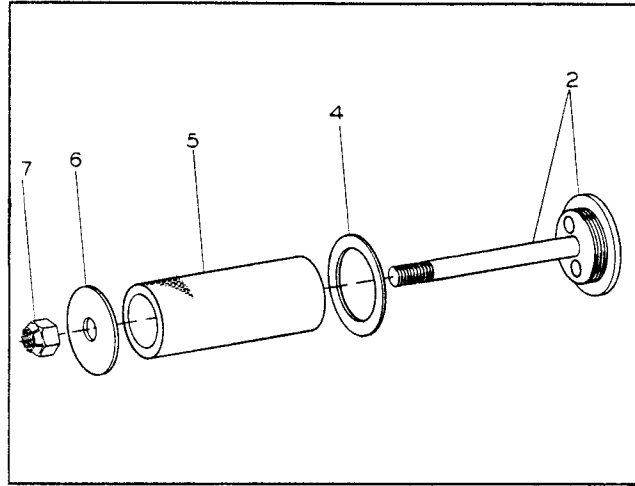

Plate 7527. Hydraulic Sump (Breather) Filter

HYDRAULIC SUMP (BREATHER) FILTER CHECK

1. Remove sump fill plug breather/s located in the upper sump tank/s at the top. See above illustrations.
2. Disassemble breather and inspect. If breather is not fit for further service (dirty or clogged with foreign material), then replacement is necessary.

3. Check both air holes for obstructions. Holes must be open.
4. Check breather gasket for further service and replace if necessary.
5. Reassemble components and install.

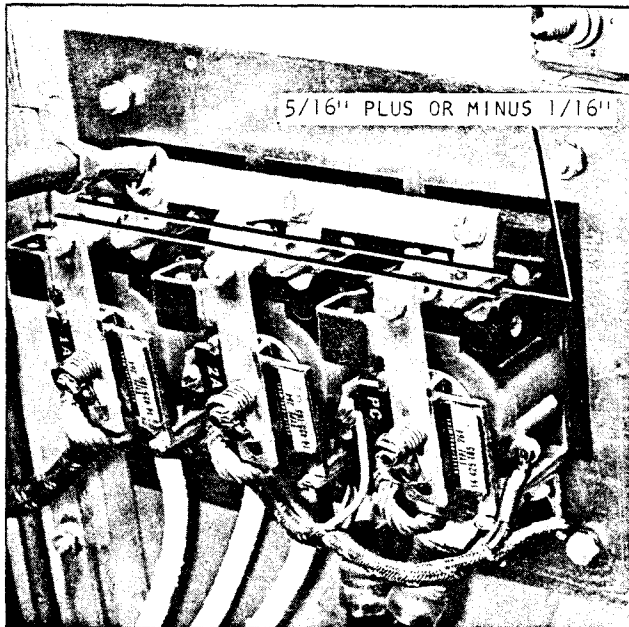

Plate 7516. Frame Mounted Contactor Panel

CONTACTORS

Keep the contactor as free from dust and dirt as possible. This can be accomplished by periodically blowing off with low air pressure or wiping with a clean dry cloth. DO NOT LUBRICATE. Contact tips are of silver alloy and require no cleaning. Replace with a new contact tip when maximum contact wear (approximately 3/32") is reached.

N O T E

If contact tip carrier and/or springs are discolored from heat, replace them as well.

Contact Tip Torque

Tighten to nominal value of 19 inch-lbs.

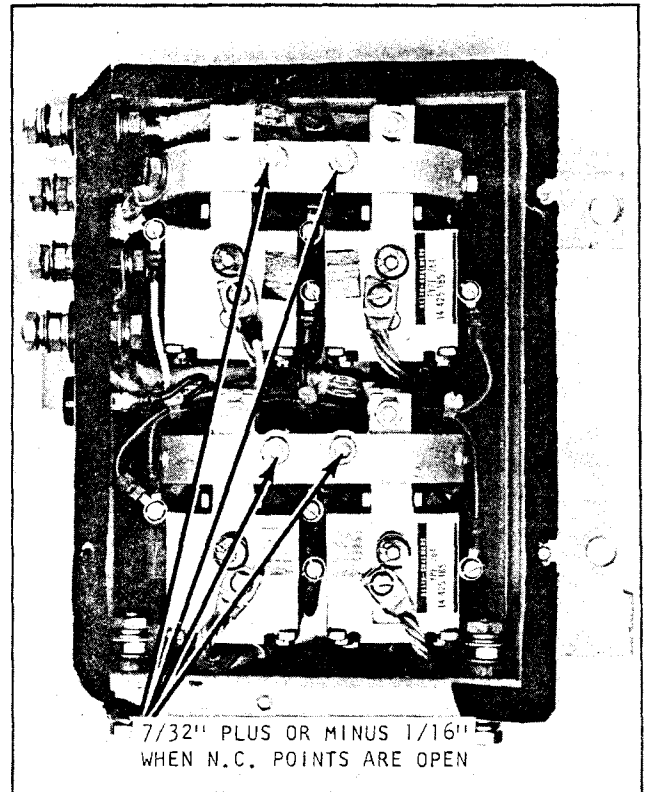

Plate 7517. Contactor Panel Mounted on Drive Unit

ADJUSTMENTS

There are no adjustments necessary on these contactors. The normally open contact gap will be 5/16" plus or minus 1/16" and the normally closed gap is 7/32" plus or minus 1/16"

The force required to separate the normally closed tips is 4 oz. (measured at the tips).

The force required to separate the normally open tips is 1-3/4 pounds (measured at tips).

The force required to seal the normally open tips is 4-1/2 pounds (measured at the armature).

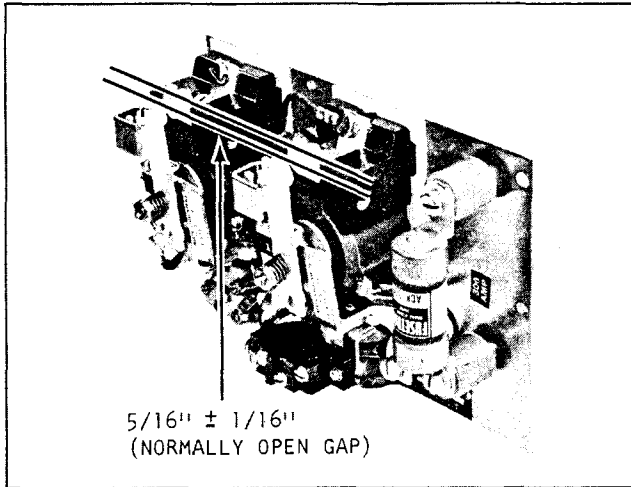

Plate 9455. Typical Frame Mounted Contactor Panel

CONTACTORS

Keep the contactor as free from dust and dirt as possible. This can be accomplished by periodically blowing off with low air pressure or wiping with a clean dry cloth. DO NOT LUBRICATE. Contact tips are of silver alloy and require no cleaning. Replace with a new contact tip when maximum contact wear (approximately 3/32") is reached.

N O T E

If contact tip carrier and/or springs are discolored from heat, replace them as well.

Contact Tip Torque

Tighten to nominal value of 19 inch-lbs.

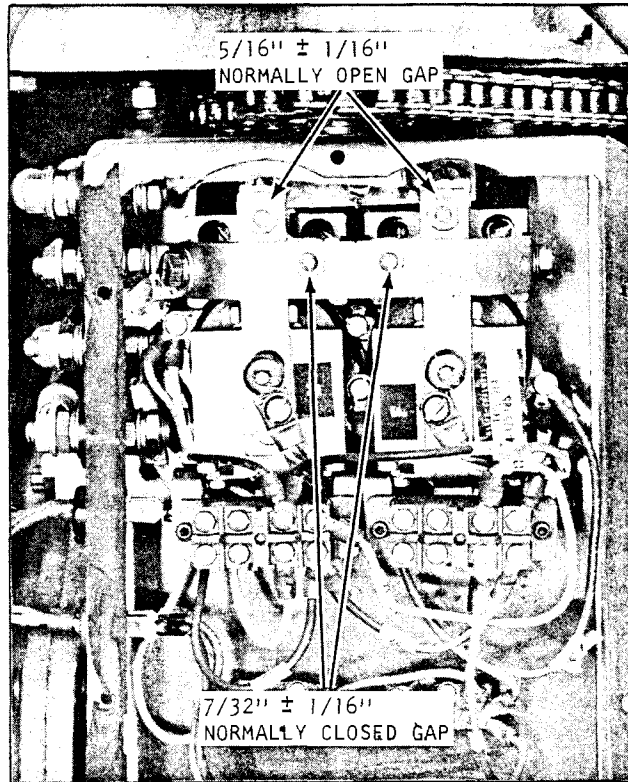

Plate 9456. Typical Contactor Panel Mounted on Drive Unit

ADJUSTMENTS

There are no adjustments necessary on these contactors. The normally open contact gap will be 5/16" plus or minus 1/16" and the normally closed gap is 7/32" plus or minus 1/16".

The force required to separate the normally closed tips is 4 oz. (measured at the tips).

The force required to separate the normally open tips is 1-3/4 pounds (measured at tips).

The force required to seat the normally open tips is 4-1/2 pounds (measured at the armature).

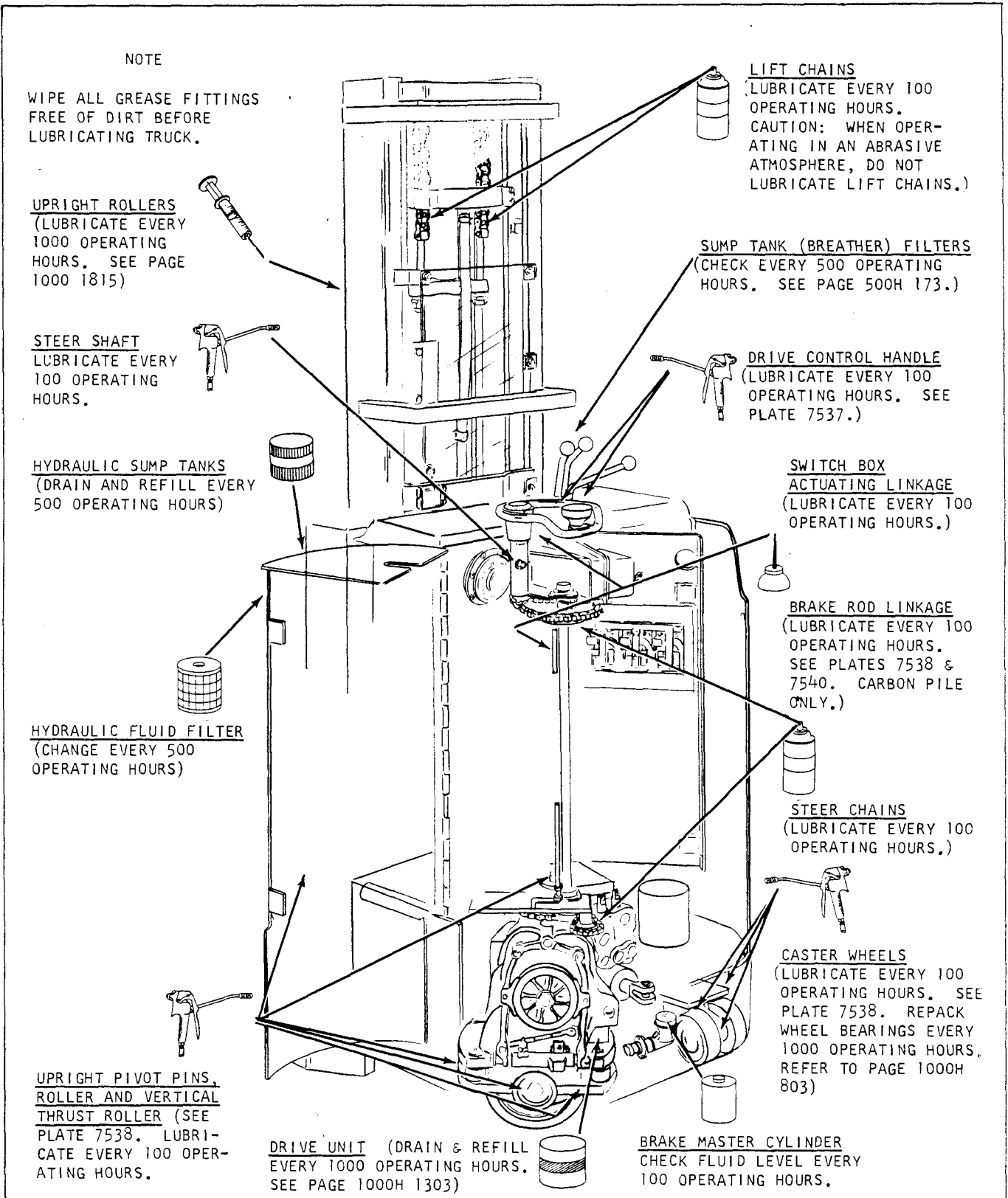

Plate 9494. Typical Lubrication Chart



INDUSTRIAL TRUCK DIVISION



LUBRICATION AND PREVENTIVE MAINTENANCE

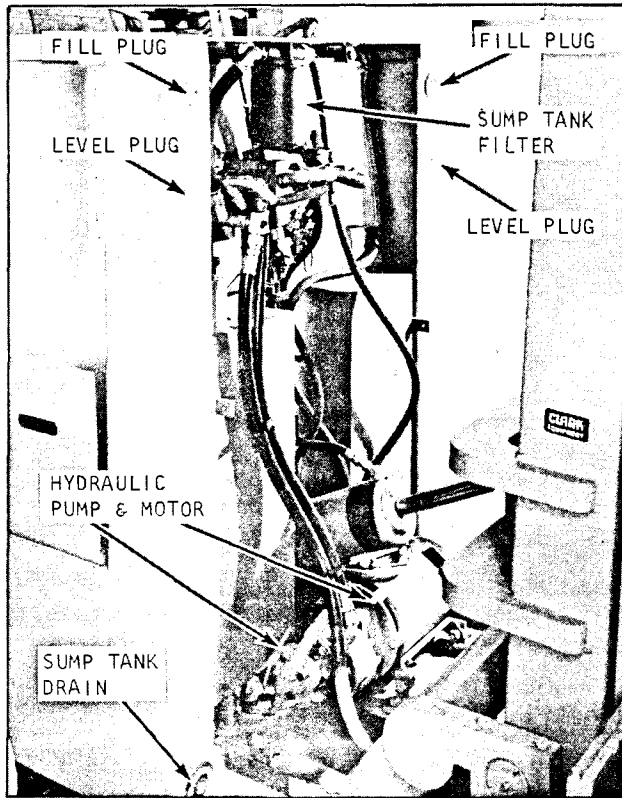

Plate 8274. Typical Hydraulic System

AMOLITH GREASE E.P.
#1 OR ITS EQUIVALENT



ENGINE OIL: S.A.E. 20



HYDRAULIC FLUID - CLARK SPEC.
MS-68, CLARK NUMBER 885385



1800200 HYDRAULIC BRAKE FLUID
HEAVY DUTY S.A.E. 70 R3



OIL FILTER
CARTRIDGE KIT



LIFT CHAIN LUBE
CLARK PART #886399



STRAIGHT MINERAL
OIL S.A.E. 90

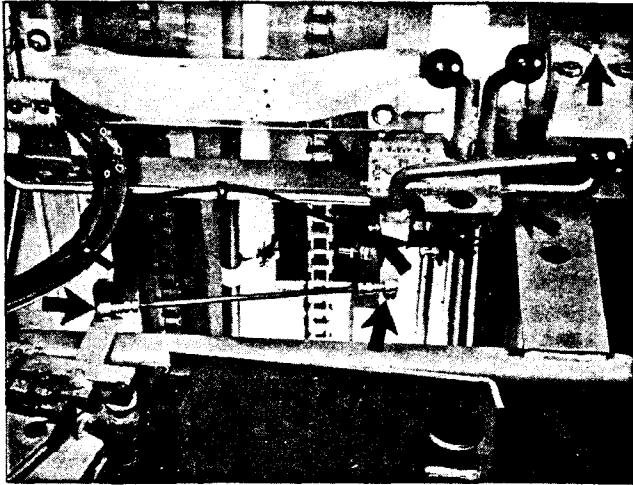

Plate 7537. Drive Control Handle Lubrication. Two grease fittings; all moving parts to be lubricated, sparingly, with S.A.E. number 20 engine oil.

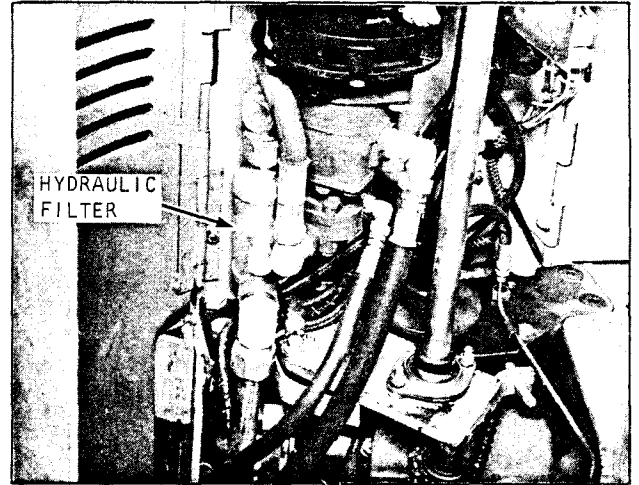

Plate 9491. Typical Hydraulic Filter
Hydraulic Filter Location

On earlier models the hydraulic filter is located on the underside of the machine.

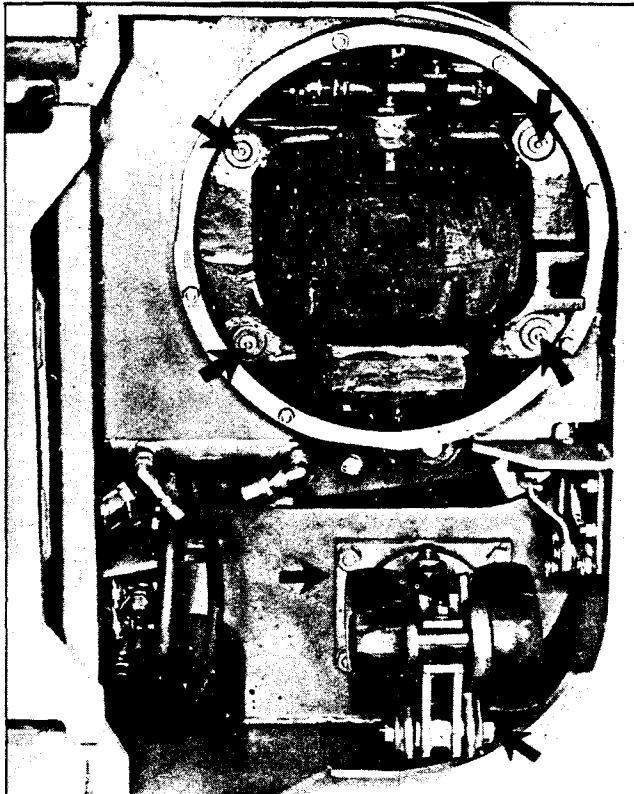

Plate 7538. Caster, Radial Roller and Wheel Shaft, Lubricate all grease fittings per Lube Chart. Lubricate brake linkage only, DO NOT LUBRICATE BRAKE, with S.A.E. number 20 engine oil every 100 operating hours.

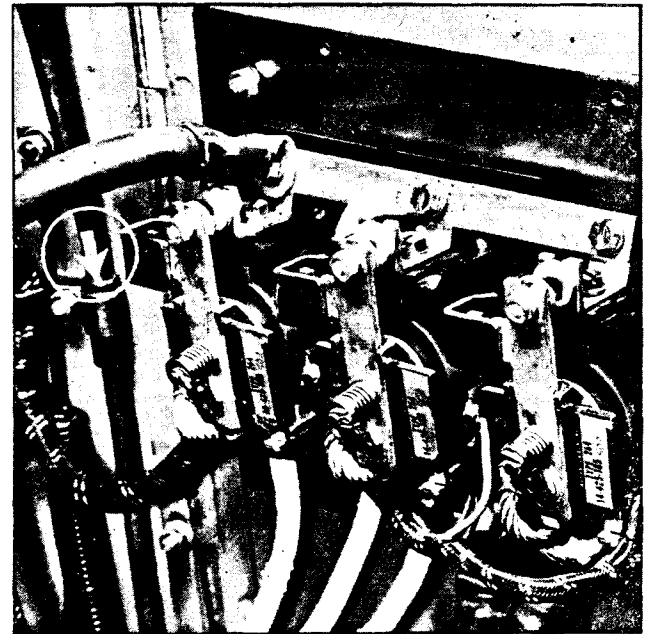

Plate 7540. Brake Rod Linkage. Lubricate with S.A.E. number 20 engine oil.

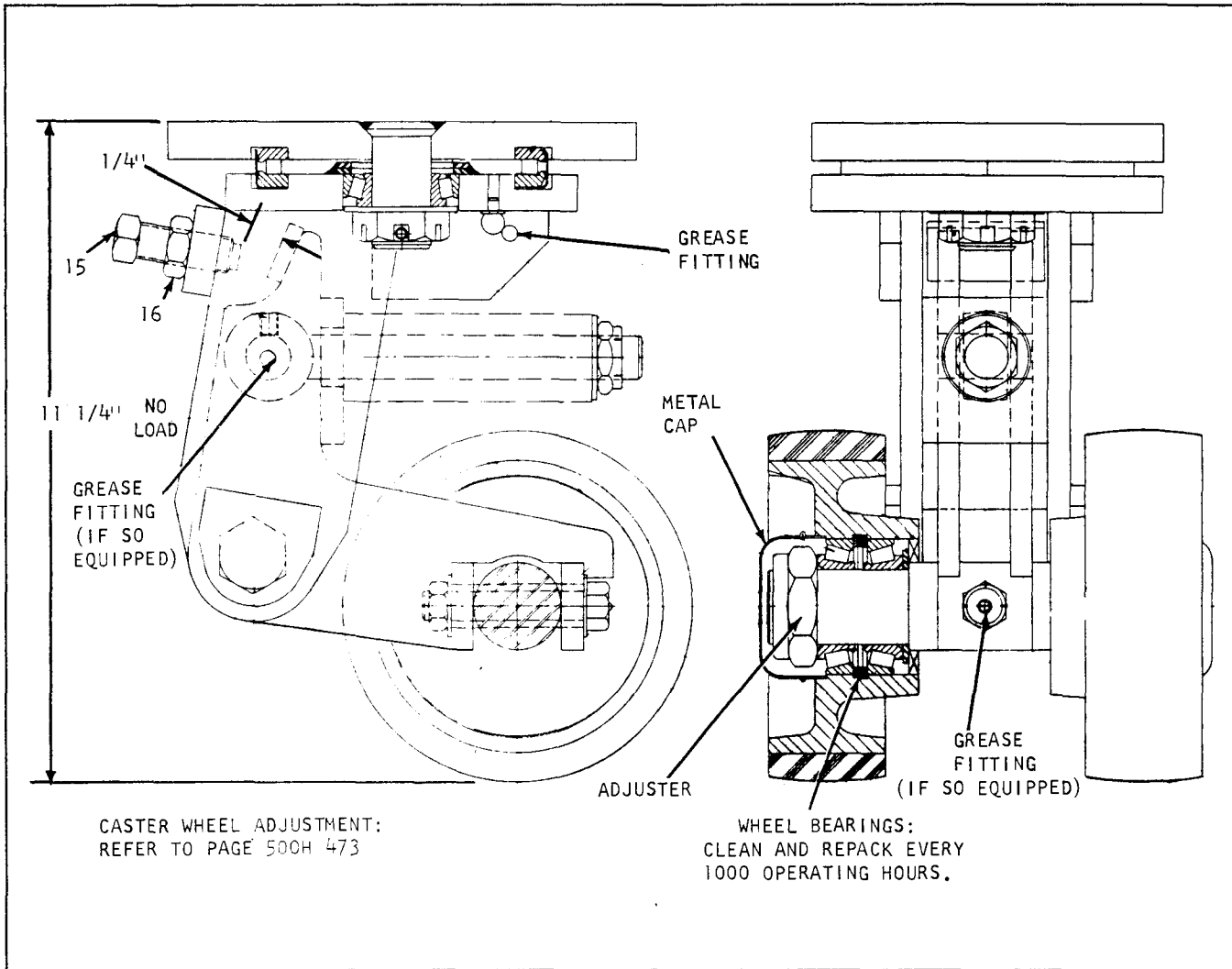

Plate 7529. Typical Caster Wheel Assembly

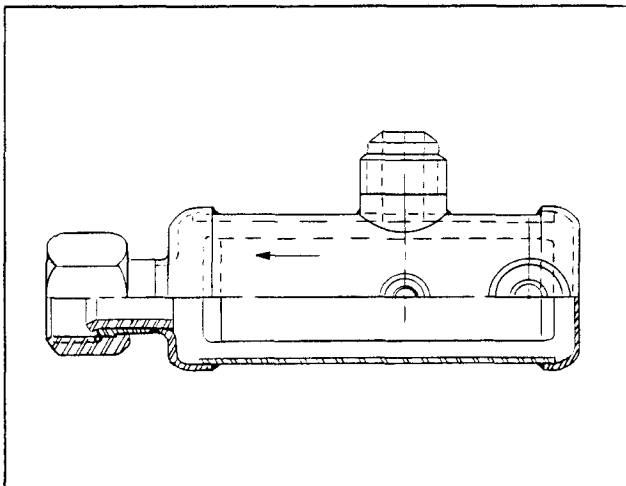

Plate 9446. Typical Hydraulic Fluid Filter

CASTER LUBRICATION

Lubricate casters at grease fitting with NLGI #2 (Amolith grease EP #2 or its equivalent).

FILTER CLEANING

Clean every 100 operating hours by immersing in solvent and blowing out with air. Blow air in nut end (against direction of arrow).

NOTE

Filter to be of 100 mesh screen.

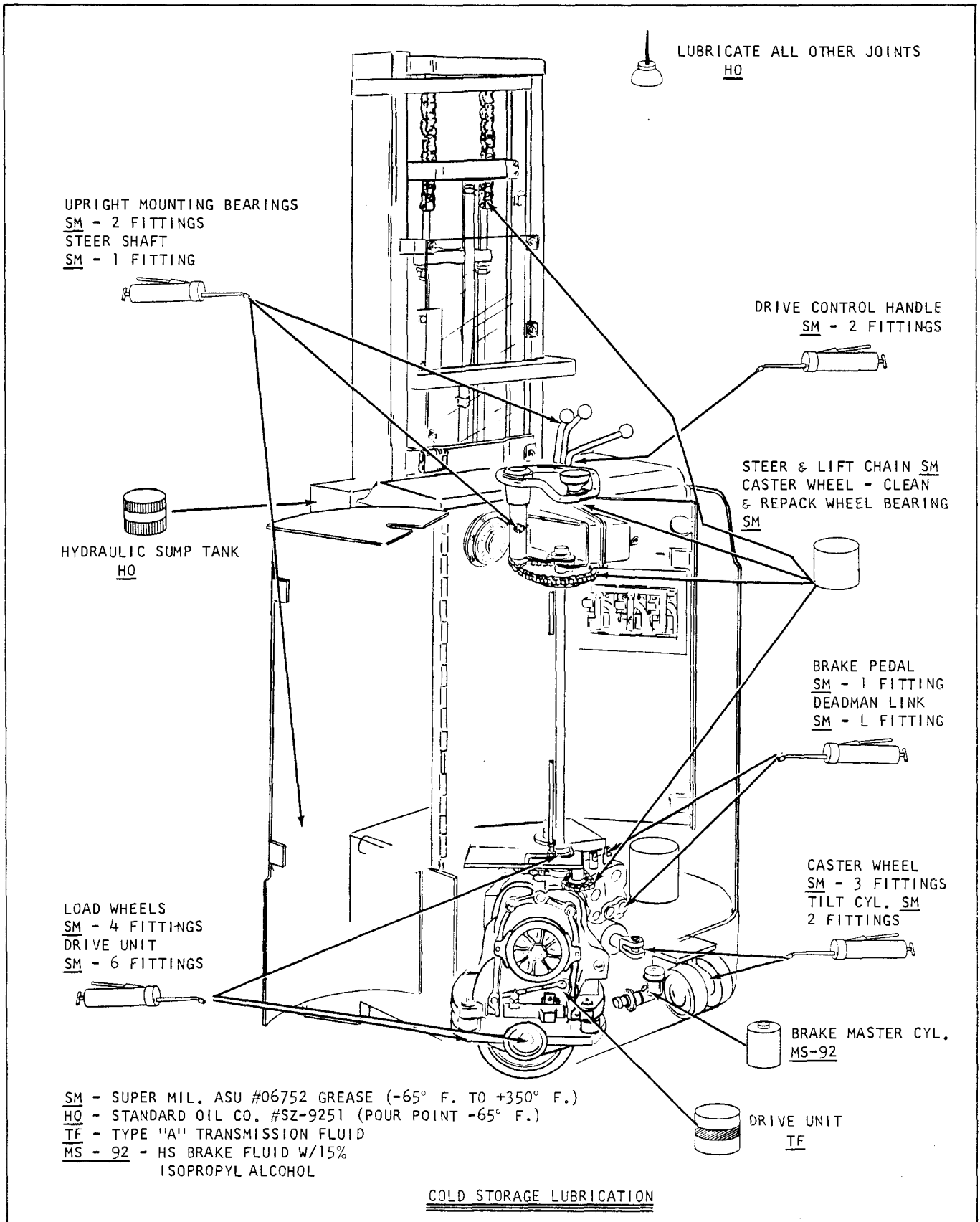

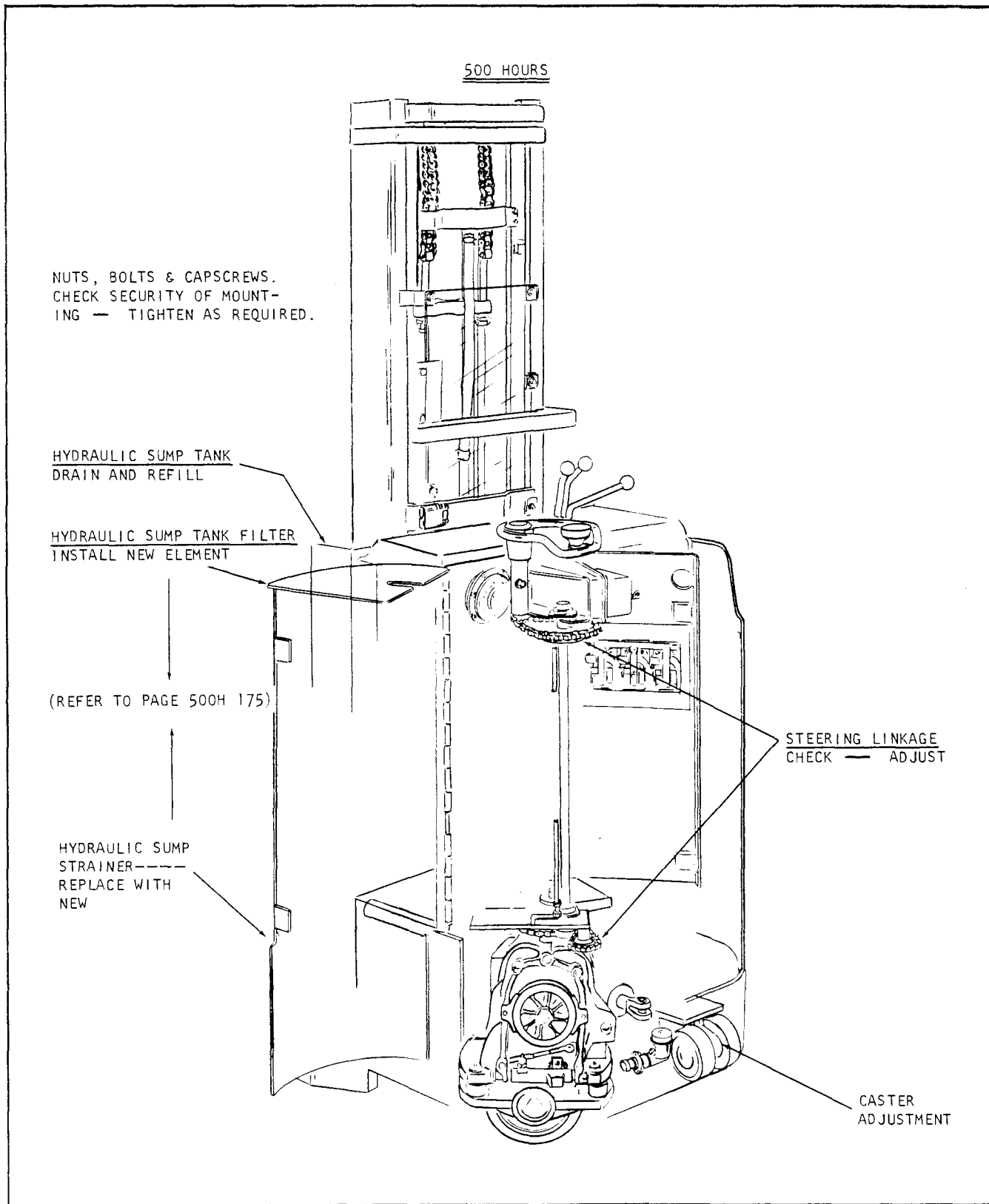

Plate 8272. Lubrication & Preventive Maintenance Illustration

DRAIN SUMP TANKS. CHANGE FILTER: CHECK BREATHER AND REPLACE WITH NEW IF NECESSARY.

CAUTION

THE HYDRAULIC SYSTEM MUST BE KEPT CLEAN. IT MAY BE NECESSARY TO DRAIN, CLEAN AND REFILL THE SUMP TANK MORE OFTEN UNDER ADVERSE CONDITIONS. THIS IS BEST DETERMINED BY CHECKING CONDITION OF THE HYDRAULIC FLUID FOR EVIDENCE OF DIRT, SLUDGE OR ANY FOREIGN MATTER AT PERIODIC INTERVALS.

1. Lower forks to the floor.
2. Turn switch key "off".
3. Place a container under each drain plug (of the hydraulic sump tanks located in the frame at each side of the upright), see Plate 8275.
4. Remove drain plugs and drain fluid.

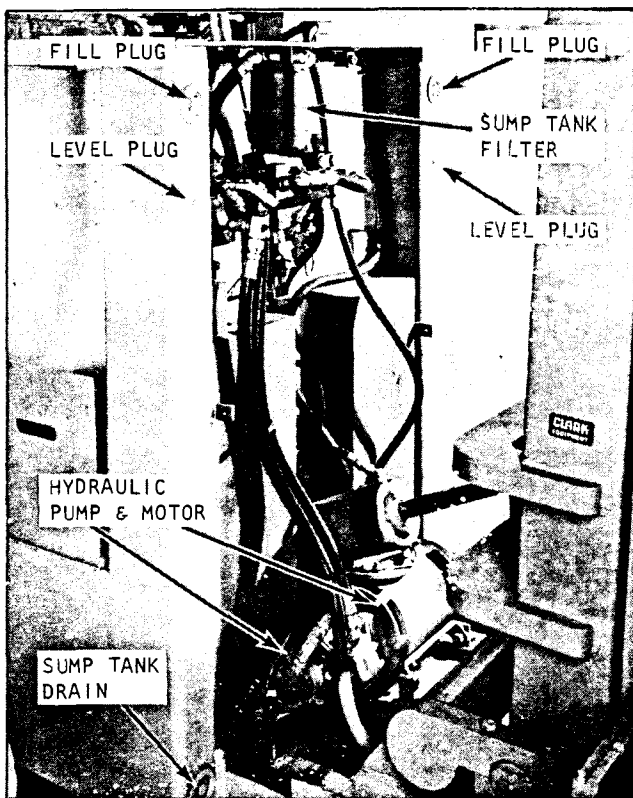

Plate 8274. Location of Sump Filter

5. Remove sump breather located in the right hand sump tank at the top. see Plate 7528 on the next page. If breather is not fit for further service (dirty, clogged with foreign material,

etc.), then replacement is necessary. Check both air holes in the breather cap for obstructions. Holes must be open (see Plate 7527 next page). Do not install breather at this time.

6. After tanks have drained, remove fill plug on left hand tank, see Plate 7528 next page. Pour at least two quarts of new hydraulic fluid thru each fill plug opening to flush tank. When tank has completely drained, replace drain plugs.

CAUTION

DO NOT START PUMP WHILE SUMP TANK IS EMPTY. DAMAGE TO HYDRAULIC PUMP WILL RESULT WITH NO FLUID IN THE SYSTEM. WHEN FILLING OR CHECKING SUMP TANK, THE UPRIGHT FORKS MUST BE LOWERED TO THE FLOOR.

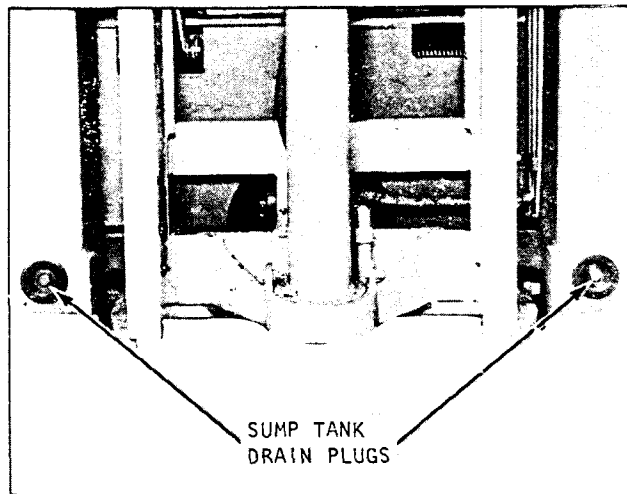

Plate 8275. Draining Sump Tank

7. Remove old hydraulic filter cartridge and discard. Install new cartridge, see Plate 8274.

8. Fill sump from either side until fluid reaches bottom of level plug holes, see Plate 7528 next page. Install level plugs finger tight. Use Hydraulic Fluid per Clark Specifications HS-68, Clark Part Number 885385.

9. Turn power key switch on and operate hydraulic control levers several times to force air, trapped in the lines, into the sump where it can escape. Turn key switch off.

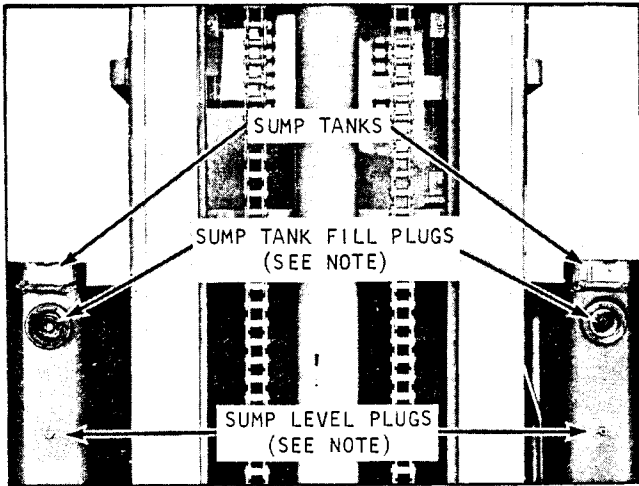

Plate 7528. Hydraulic Sump Tanks

10. Check fluid level at level plugs — add fluid if necessary. Replace and tighten level plugs. Install sump breather in the R.H. sump tank (as viewed from the front of machine). Install fill plug in the L.H. sump tank.

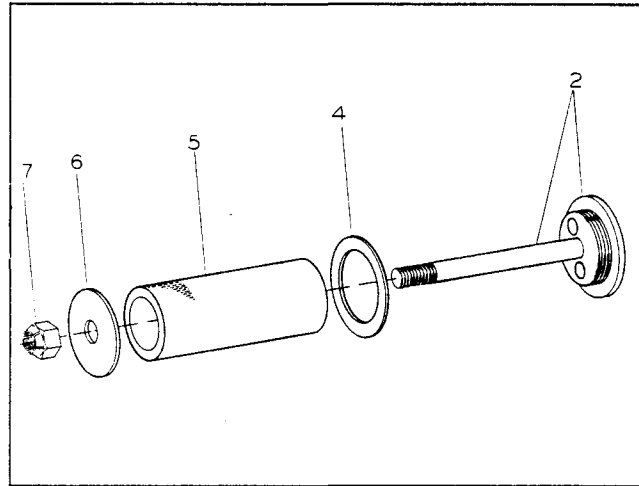

Plate 7527. Hydraulic Sump Tank Breather

C A U T I O N

ALWAYS OPERATE HYDRAULIC CONTROL LEVERS SEVERAL TIMES AFTER FILLING SUMP TANK TO PURGE AIR FROM THE SYSTEM. CHECK OIL FILTER FOR LEAKS AND RECHECK FLUID LEVEL AFTER PURGING AIR FROM THE SYSTEM.

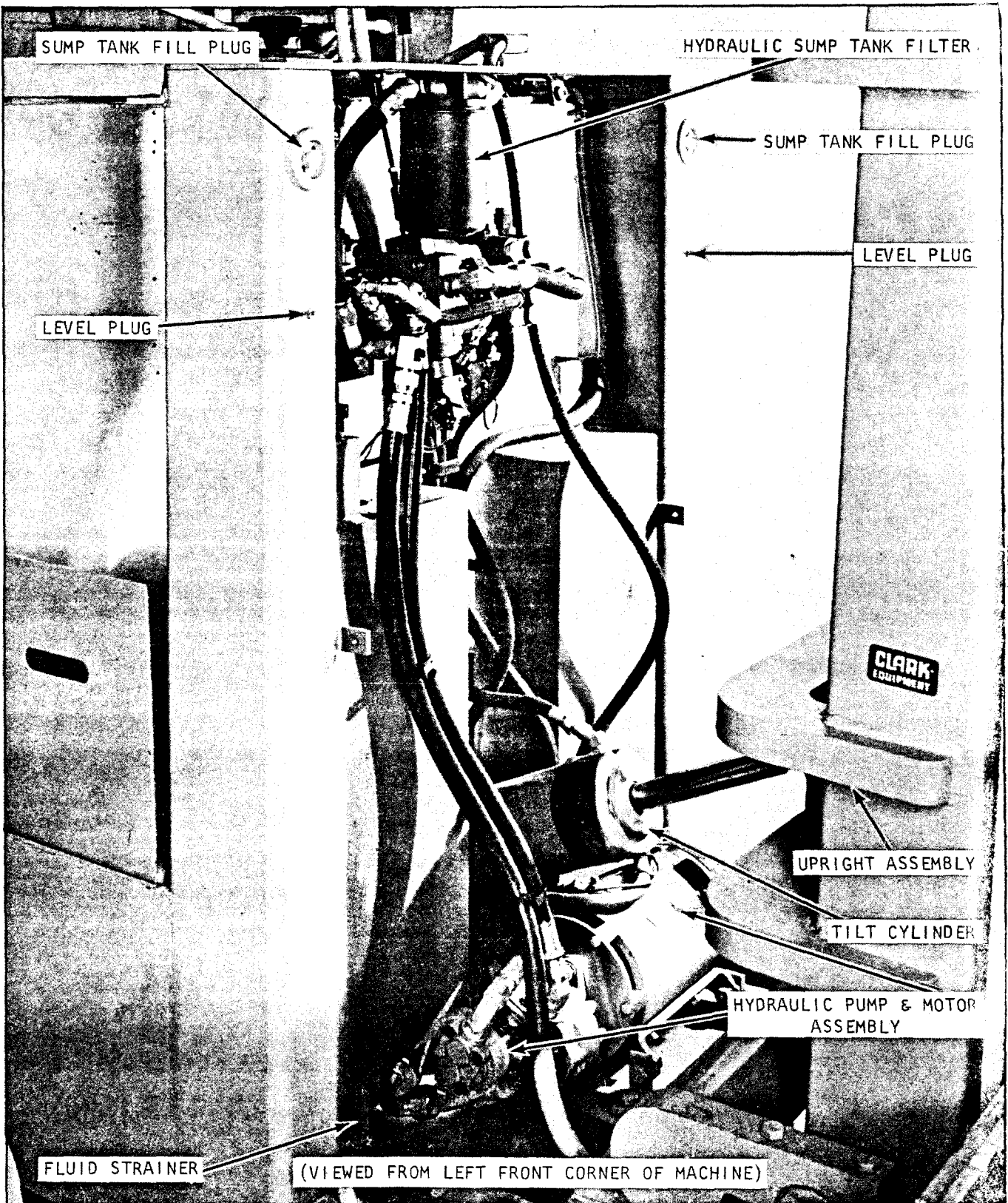

Plate 8279. (VIEWED FROM LEFT FRONT CORNER OF MACHINE)
WHEN FACING FRONT OF MACHINE

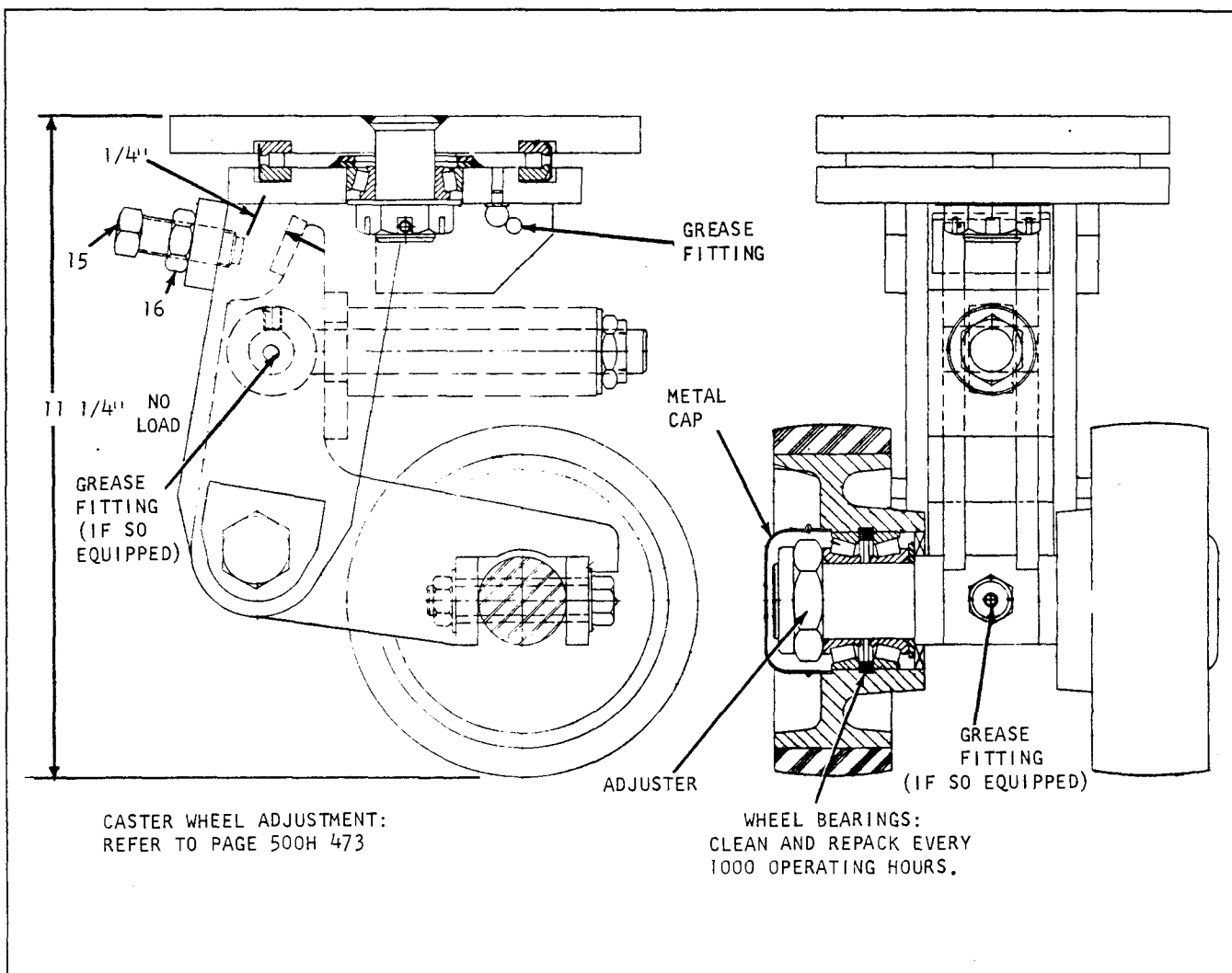

Plate 7529. Typical Caster Wheel Assembly

CASTER ADJUSTMENT

Caster should have 1/4 inch vertical travel. Check periodically for reduction in travel due to wear of drive tire as follows:

1. Loosen Jam Nut (16) and back out Set Screw (15) about 1/4 of an inch.
2. Drive caster wheel only, onto a 1/4 inch metal plate resting on a flat level floor.
3. Screw in Setscrew (15) finger tight until it bottoms against its stop.
4. Tighten Jam Screw (16) securely. This is the entire adjustment.

Total adjustment allows for about 3/4 inch wear off radius of drive tire before replacement is indicated.

NOTE

This adjustment should be performed every 500 operating hours unless indicated otherwise by tire wear rate experience.

General Information

Spring Arrangement - 51 Belleville washers in 17 stacks of 3 alternating. Concave face of first stack toward bolt eye.

Preload: 1300 lbs. at 11" O.A. free height. Adjustable stop preset at 10 3/4" O.A.H.

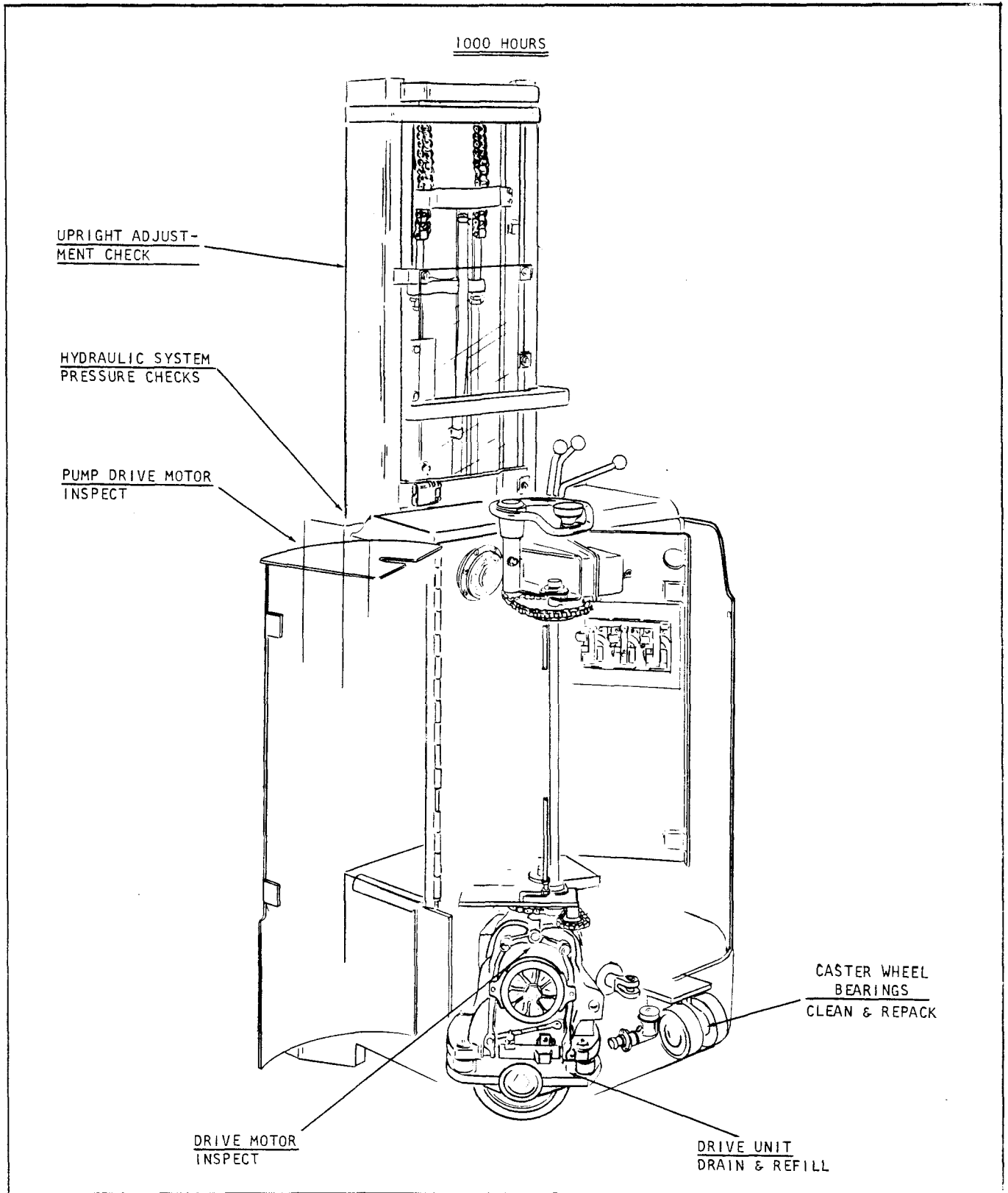

Plate 8273. Lubrication & Preventive Maintenance Illustration

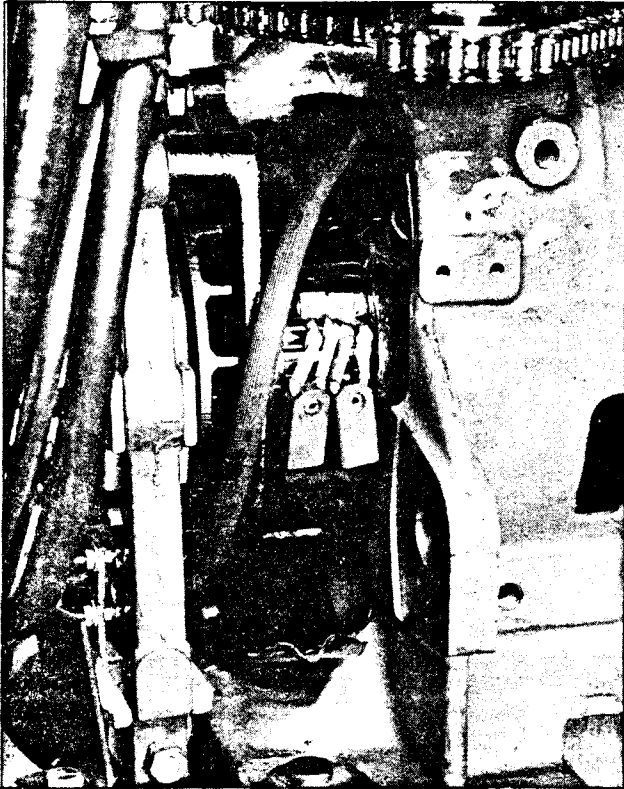

Plate 7518. Typical Drive Motor

DRIVE MOTOR

Wiring: Inspect all connecting wires to be sure they are secure. Insulation should not be worn or damaged.

Commutator: If commutator is glazed or dirty, clean with a strip of No. 00 sandpaper. Blow out all dirt and grit with compressed air.

CAUTION

DO NOT USE EMERY CLOTH TO CLEAN COMMUTATOR.

Brushes: The brushes should slide freely in their holders and make full contact on the commutator. Worn brushes

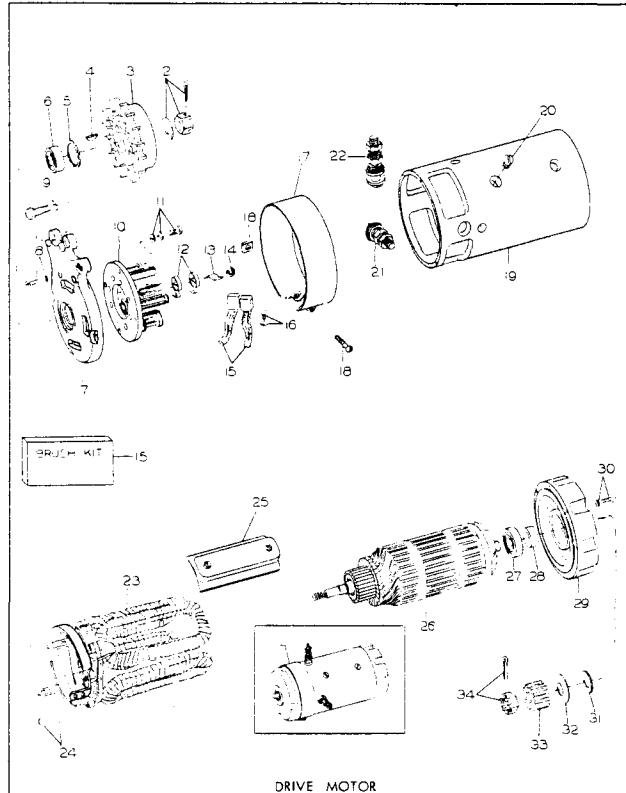

Plate 7519. Typical Drive Motor

(length of worn out brushes 5/16") should be replaced. Badly chipped, broken or oil soaked brushes should also be replaced. Brushes may be wiped with a dry clean cloth to remove loose particles of dirt.

CAUTION

DO NOT CLEAN THE BRUSHES IN ANY KIND OF SOLVENT OR ALLOW THEM TO COME IN CONTACT WITH GREASE OR OIL.

Length of new brush is 1-1/16"

Length of worn out brush 5/16"

Length of usable brush 3/4"

Brush Spring Tension: If the tension is too great, the commutator and brushes will wear excessively. Conversely, if the tension is not great enough, arcing will occur causing damage to the commutator. To change brush spring tension, twist the spring at the holder with long nose pliers.

C A U T I O N

DO NOT ALLOW SPRING TO SNAP DOWN ON BRUSH.

Spring tension should be adjusted so that each brush has the correct tension (see below). Adjust the spring tension to the high limit of the specification. This will allow the spring to maintain adequate pressure for a longer period of time as tension will gradually decrease due to shortening of the brush caused by normal wear. Use a suitable spring scale to measure the pressure of the brush on the commutator. With a thin strip of paper placed between the brush and commutator, pull up on the spring scale and slightly pull on the paper. When the pressure of the brush is reduced enough to allow the paper to be pulled out, read the indication on the scale.

BRUSH SPRING TENSION

Early Models (red springs):

- New 6.5-7 lbs.
- Old 2-2.5 lbs.

Late Models (yellow springs):

- New 35-40 oz.
- Old 14 oz. min.

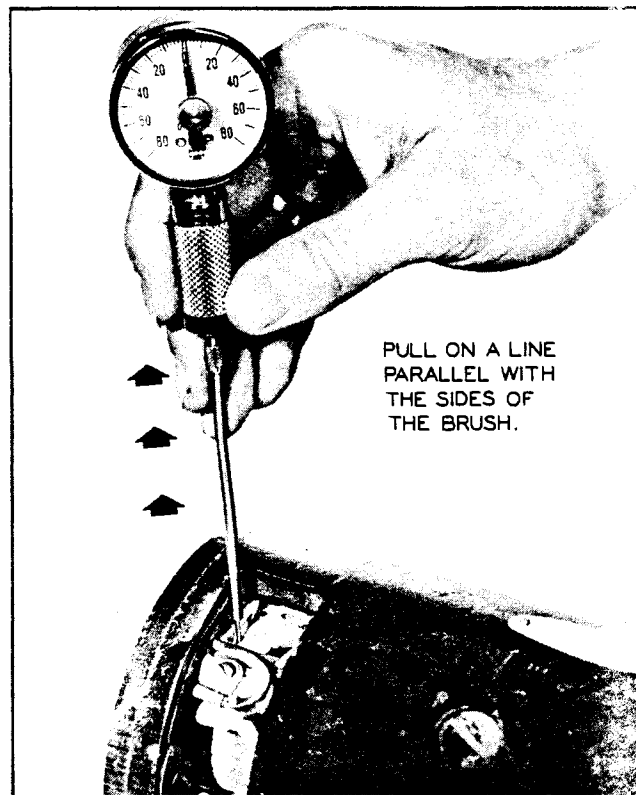

Plate 6450. Checking Brush Spring Tension

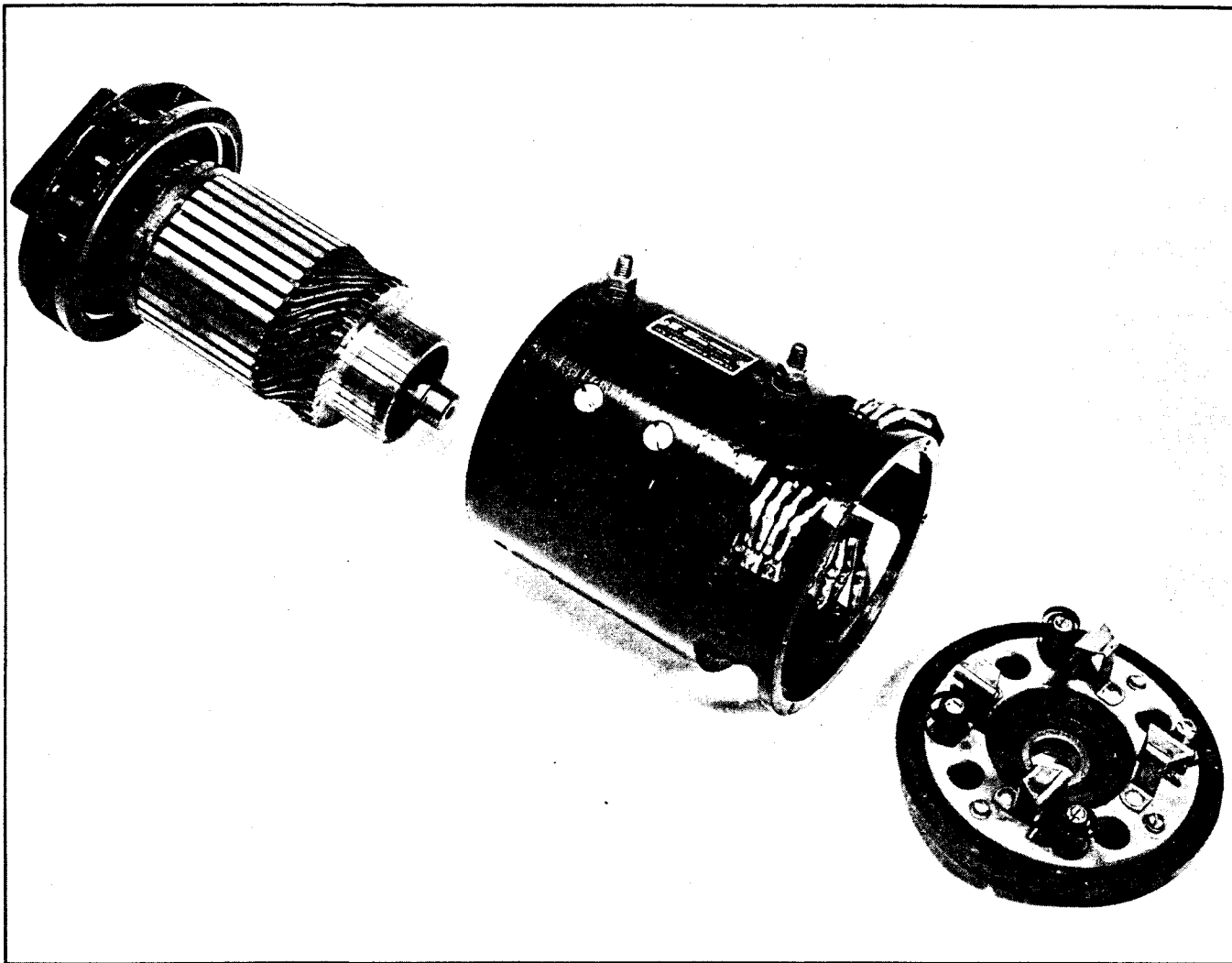

Plate 7530. Typical Pump Drive Motor

PUMP MOTOR

Wiring: Inspect all connecting wires to be sure they are secure. Insulation should not be worn or damaged.

Commutator: If commutator is glazed or dirty, clean with a strip of No. 00 sandpaper. Blow out all dirt and grit with compressed air.

C A U T I O N

DO NOT USE EMERY CLOTH TO CLEAN COMMUTATOR.

Brushes: The brushes should slide freely in their holders and make full

contact on the commutator. Worn brushes (length of worn out brush: 5/16 inch) should be replaced. Badly chipped, broken or oil soaked brushes should also be replaced. Brushes may be wiped with a dry clean cloth to remove loose particles of dirt.

C A U T I O N

DO NOT CLEAN THE BRUSHES IN ANY KIND OF SOLVENT OR ALLOW THEM TO COME IN CONTACT WITH GREASE OR OIL.

Brush Spring Tension: If the tension is too great, the commutator and brushes will wear excessively. Conversely, if the tension is not great enough, arcing will occur causing damage to the commutator. To change brush spring tension, twist the spring at the holder with long nose pliers.

C A U T I O N

DO NOT ALLOW SPRING TO SNAP DOWN ON BRUSH.

Spring tension should be adjusted so that each brush has the correct tension (see below). Adjust the spring tension to the high limit of the specification. This will allow the spring to maintain adequate pressure for a longer period of time as tension will gradually decrease due to shortening of the brush caused by normal wear. Use a suitable spring scale to measure the pressure of the brush on the commutator. With a thin strip of paper placed between the brush and commutator, pull up on the spring scale and slightly pull on the paper. When the pressure of the brush is reduced enough to allow the paper to be pulled out, read the indication on the scale.

BRUSH SPRING TENSION

Early Models (red springs):

- New 6.5-7 lbs.
- Old 2-2.5 lbs.

Late Models (yellow springs):

- New 35-40 oz.
- Old 14 oz. min.

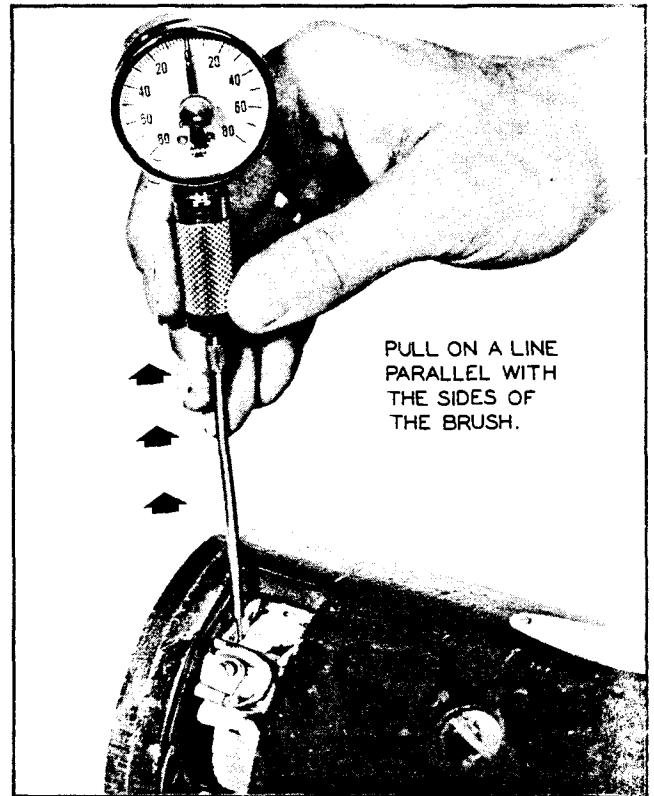

Plate 6450. Checking Brush Spring Tension

BRUSH SPECIFICATIONS

- Length of new brush is.....1-1/16 inch
- Length of worn out brush is.....5/16 inch
- Length of useable brush is.....3/4 inch

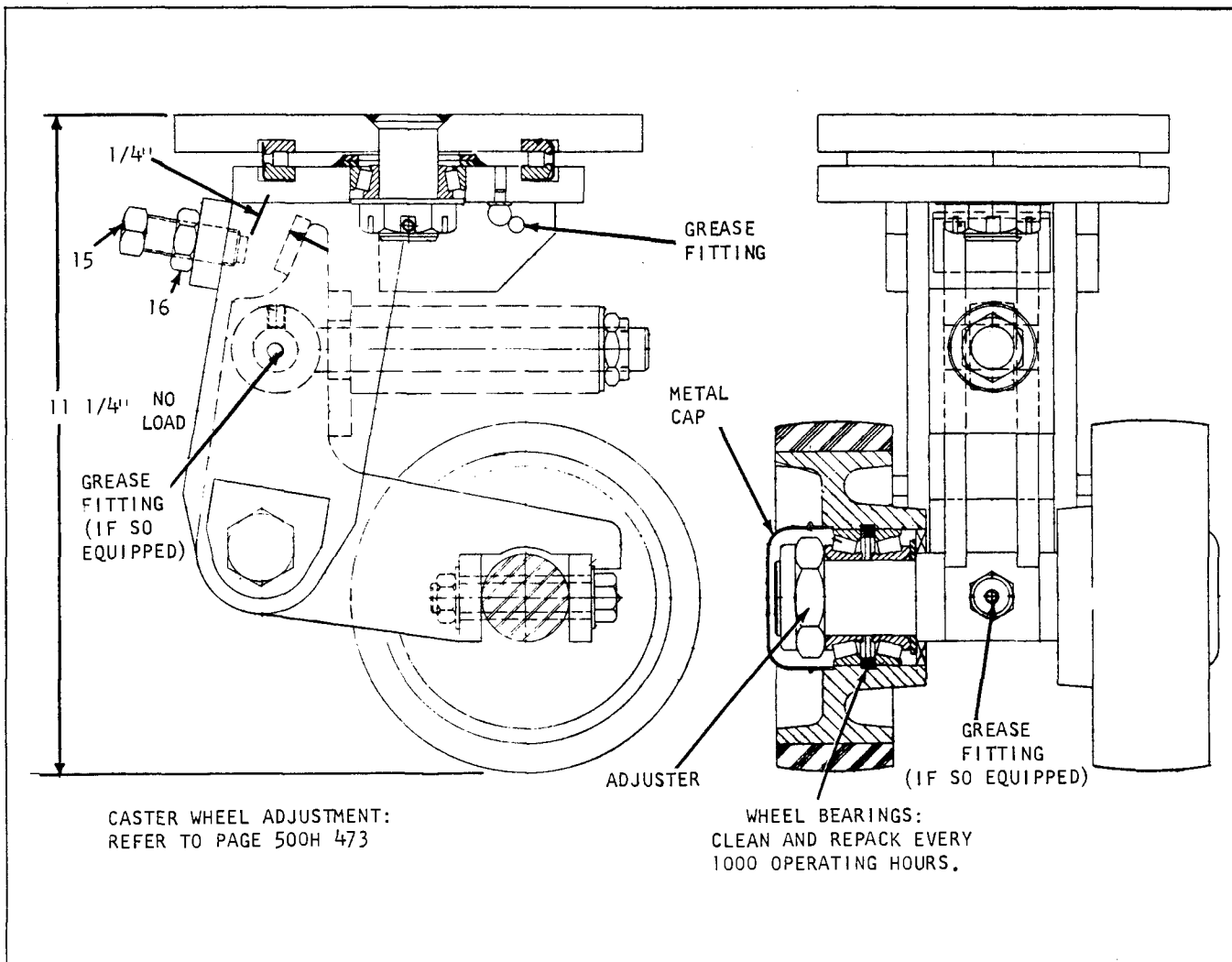

Plate 7529. Typical Caster Wheel Assembly

CASTER WHEEL BEARING LUBRICATION AND ADJUSTMENT

Remove, clean and repack the bearings every 1000 operating hours. Use NLG1 #1 (Amolith Grease EP #1 or its equivalent.)

Check grease seals for further serviceability, replace if required.

Adjust bearings after lubrication.

1. Tighten adjuster until wheel is snug then back off 1/8 to 1/4 turn.

2. Tap each side of wheel hub with a mallet to position the bearing cups and free the wheel.

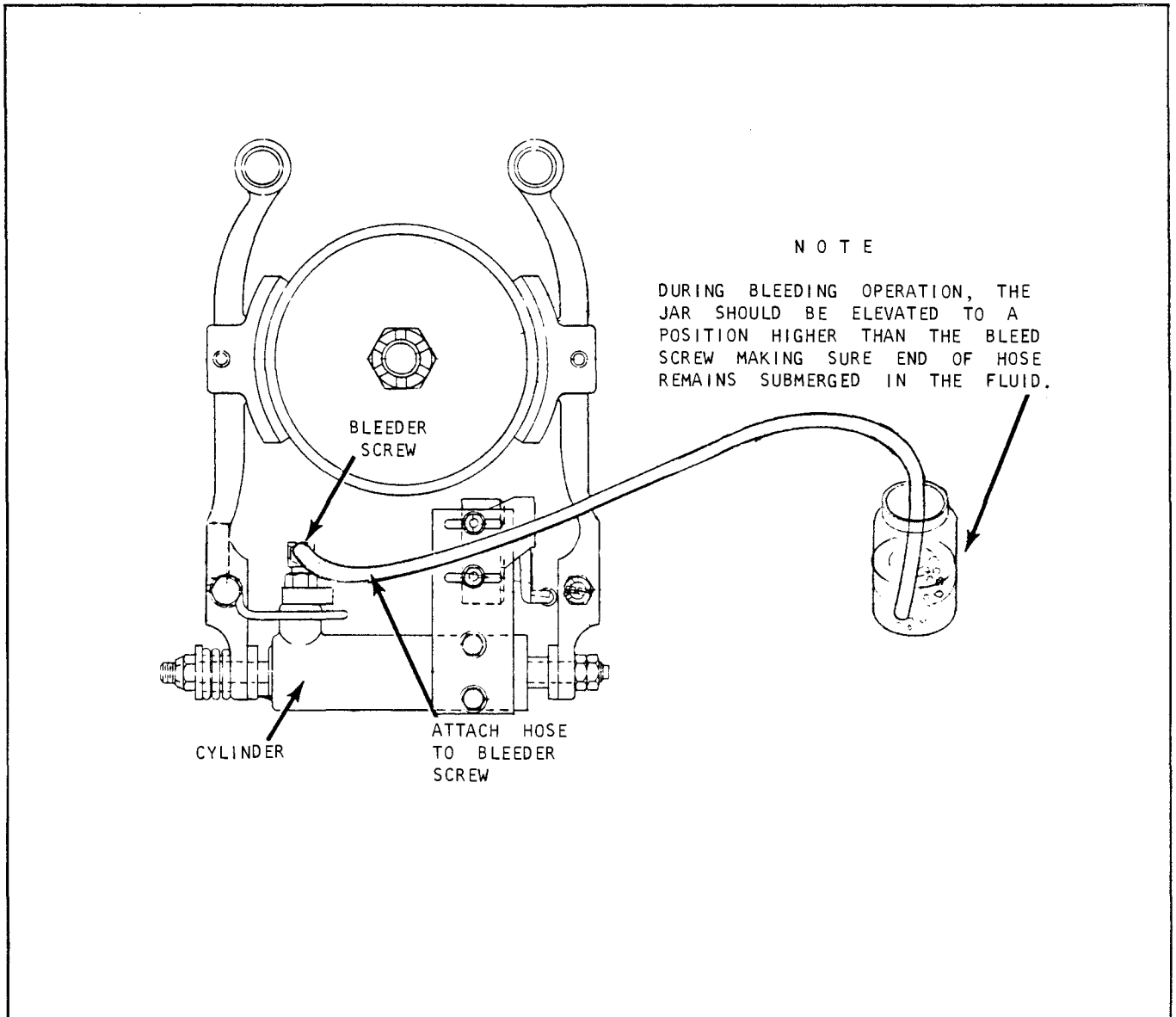

Plate 7531. Service-Parking Brake

BLEEDING PROCEDURE

1. Clean dirt from around filler cap of the master cylinder. Remove cap. Brake fluid should be within 1/4 of an inch from the top.

CAUTION

KEEP BRAKE FLUID OFF DRUM, SHOES AND LININGS.

2. Install a bleeder hose on the cylinder bleeder screw and submerge the unattached end of the hose in a clean transparent jar containing several inches of brake fluid. NOTE: DURING BLEEDING OPERATION, THE JAR

SHOULD BE ELEVATED TO A POSITION HIGHER THAN THE BLEEDER SCREW MAKING SURE THAT THE END OF THE HOSE REMAINS SUBMERGED IN THE FLUID AT ALL TIMES.

3. Loosen bleeder screw and slowly depress brake pedal to the down position (hold pedal in this position) watch fluid flow from bleeder screw and close connection before flow stops, then release pedal. Repeat this operation until fluid appears clear of air bubbles. Check master cylinder reservoir level periodically during bleeding operation, fill to within 1/4 of an inch of the top with S.A.E. 70R3 heavy duty brake fluid. Clark Part Number 1800200.



INDUSTRIAL TRUCK DIVISION



LUBRICATION AND PREVENTIVE MAINTENANCE

- TO ADJUST BRAKE -

1. LOOSEN BLEEDER SCREW "A" AND BLEED OUT ALL AIR (CAUTION - KEEP BRAKE FLUID OFF DRUM AND SHOES), REFER TO OPPOSITE PAGE FOR BLEEDING PRODECURES. AFTER BLEEDING CHECK ADJUSTMENTS AS OUTLINED BELOW.
2. ADJUST FOR GRADUAL BRAKE APPLICATION BY ADJUSTING GAP "X" TO 3/16" WITH NUT "B". (NOTE - NUT "C" TO BE SUFFICIENTLY TIGHT SO BUSHING INSIDE OF SPRING WILL NOT PULL AWAY FROM BRAKE ARM)
3. ADJUST BRAKE HOLDING TORQUE BY RAISING DRIVE TIRE FROM FLOOR AND ADJUSTING NUT "C" UNTIL TORQUE WRENCH READS CORRECT RATING (TABLE "D") WITHOUT DRUM SLIPPING. SAFELY BLOCK MACHINE. REFER TO PAGE 100H 303.
4. ADJUST L.H. BRAKE ARM STOP "E" FOR APPROXIMATELY 1/32 GAP.
5. ADJUST BRAKE SWITCH TO OPEN BEFORE R.H. BRAKE SHOE TOUCHES DRUM.

- TO ADJUST FOR LINING WEAR -

6. REPEAT STEPS 1 THRU 5; WHEN WEAR BECOMES TOO GREAT FOR THIS ADJUSTMENT MOVE SPACERS "F" TO OUTSIDE OF BRAKE ARMS. - THEN REPEAT STEPS 1 THRU 5.

TABLE "D"

| MODEL | WEIGHT LOADED | "T" - POUND - INCHES 18.36-1 |
|-------|----------------|---------------------------------|
| NST20 | 1,500 2,000 | 275 |
| NST30 | 2,500 3,000 | 300 |
| NST40 | 4,000 | 375 |

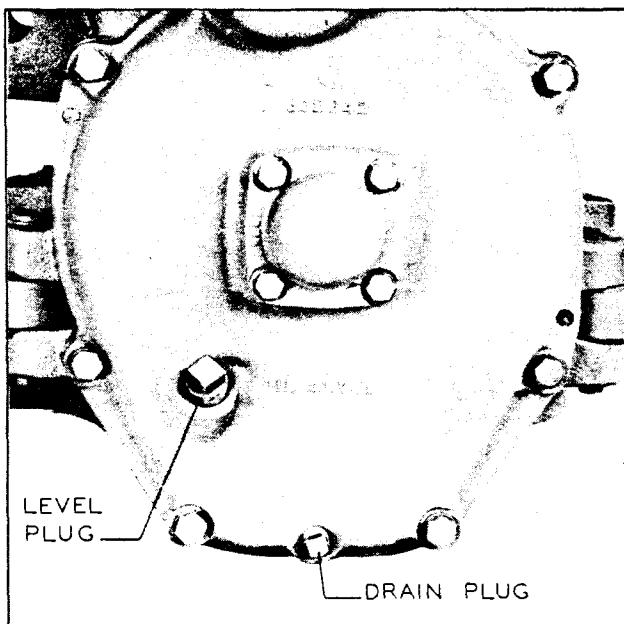

Plate 4274. Drive Unit Assembly

DRIVE UNIT DRAIN AND REFILL

1. Remove drain plug and allow drive unit to "completely" drain.
2. Replace drain plug.
3. Clean any dirt from around level plug and remove plug.
4. Fill with S.A.E 90 gear lubricant until level reaches the height of the level plug. DO NOT overfill, as the excess quantity will serve no useful purpose. If the oil level is too high, it will cause excessive churning and attendant high oil temperature and possible leakage.
5. Replace level plug.

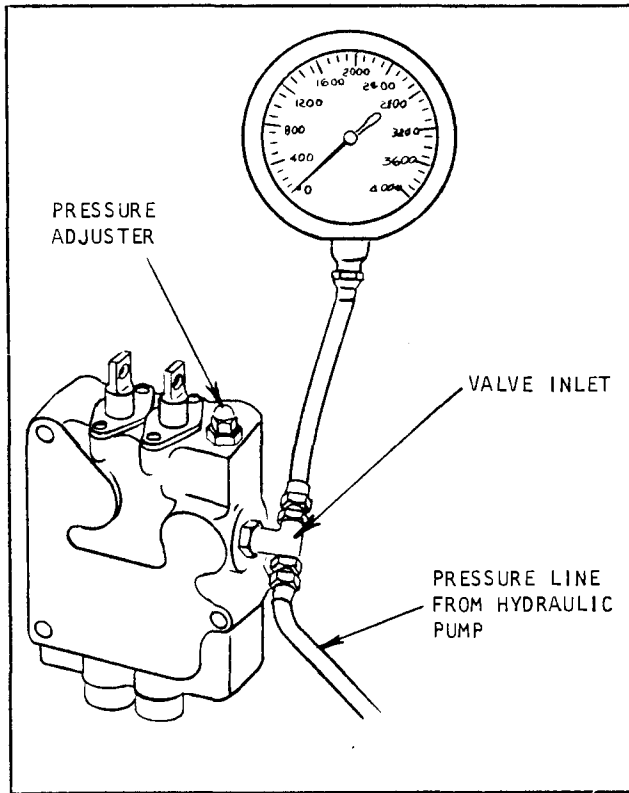

Plate 7333. Typical method for checking Hydraulic System Pressure

HYDRAULIC SYSTEM PRESSURE CHECKS

1. Remove the pressure check plug (if so equipped) from either valve and install a 0 - 4000 P.S.I. pressure gauge. If valve is not equipped with plug, then provide a suitable means for connecting a gauge at the inlet side of valve. A "tee" at the inlet side may be used.

2. Turn key switch on and operate a hydraulic control lever to extend, lift or reach (depending upon which circuit and valve is to be tested) position. When the hydraulic cylinder or cylinders reach the end of their travel, check gauge reading. Pressure should be within the limits listed in Specifications.

NOTE

DO NOT HOLD A CONTROL LEVER IN AN ACTUATED POSITION FOR ANY PROLONGED PERIOD AFTER THE CYLINDER OR CYLINDERS HAVE REACHED THE END OF THEIR (LIMIT) TRAVEL. THIS WILL CAUSE HEATING OF THE HYDRAULIC FLUID AND SHOULD BE AVOIDED.

If pressure is not as specified, report to designated person in authority.

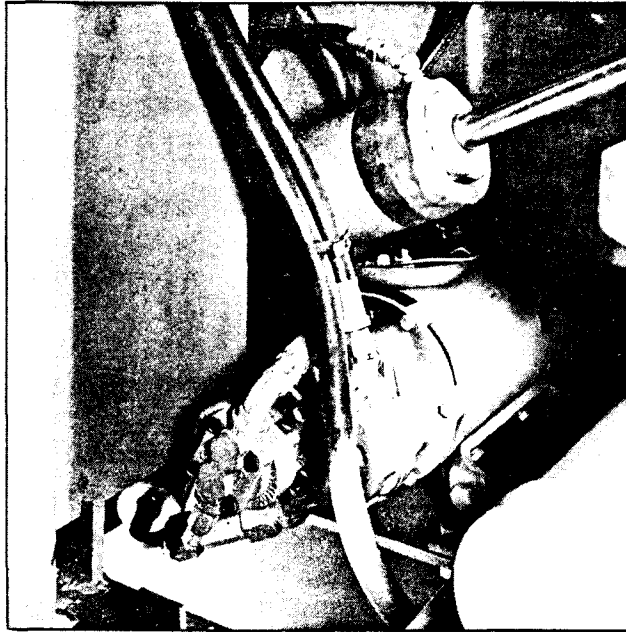

Plate 8304. Hydraulic Pump and Motor

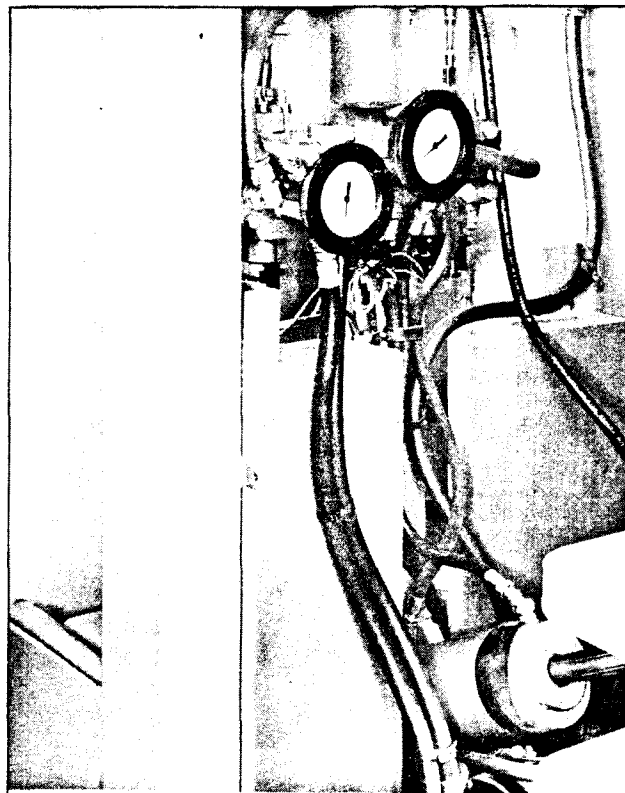

Plate 8305. Checking System Pressure



INDUSTRIAL TRUCK DIVISION



LUBRICATION AND PREVENTIVE MAINTENANCE

HYDRAULIC SYSTEM CHECKS

- Pressure Checks -

1. Remove the pressure check plug (if so equipped) then install a 0 - 3000 PSI pressure gauge as shown in Plate 8305. If plugs are not provided, then provide a suitable means for connecting a gauge to the connections as shown. A "tee" may be used similar to that shown in the illustration.
2. Turn key switch on and operate a hydraulic control lever (depending upon which pump is to be tested). When the hydraulic cylinder or cylinders reach the end of their travel, check gauge reading. Pressure should be within the limits listed below.

N O T E

Do not hold a control lever in an actuated position for any prolonged period after the cylinder or cylinders have reached the end of their (limit) travel. This will cause heating of the hydraulic fluid and should be avoided.

If pressure is not as specified, report to designated person in authority.

- Flow Checks -

3. Remove pressure gauges and install flow gauges in their place.
4. Follow Step 2 and check for the specified hydraulic flow listed below.

If flow is not as specified, report to designated person in authority.

FLOW IN GPM/PUMP RPM

| <u>NST 15-20-25-30-40</u> | <u>300 PSI</u> | <u>1000 PSI</u> | <u>1500 PSI</u> |
|--|-------------------|------------------|------------------|
| <u>TANDEM PUMP</u> <u>LIFT PUMP</u> | 10 GPM/2650 RPM | 7.3 GPM/2000 RPM | 5.8 GPM/1650 RPM |
| TILT/REACH PUMP | 2.3 GPM/35000 RPM | 2 GPM/3000 RPM | 1.5 GPM/2550 RPM |

REFER TO ILLUSTRATIONS ON OPPOSITE PAGE

LUBRICATION AND PREVENTIVE MAINTENANCE

LIFT CARRIAGE AND UPRIGHT
ROLLER ADJUSTMENTS

To maintain top performance from the upright it may be necessary, from time to time, to adjust the rollers located on the Lift Carriage and Upright Assembly. These adjustments may be accomplished as follows:

Before checking for proper roller clearance, check to be sure the Inner Slide contacts with

both Fabreeka (Stop) Pads at the same time when lowering the Inner Slide.

If adjustment is required, add or remove shims between Fabreeka (Stop) Pads located on the Outer Rail Tie Bar Assembly.

NOTE: More shims may be required on one side than the other in order to allow the Inner Slide to come in contact with both Fabreeka (Stop) Pads at the same time when lowering the Inner Slide.

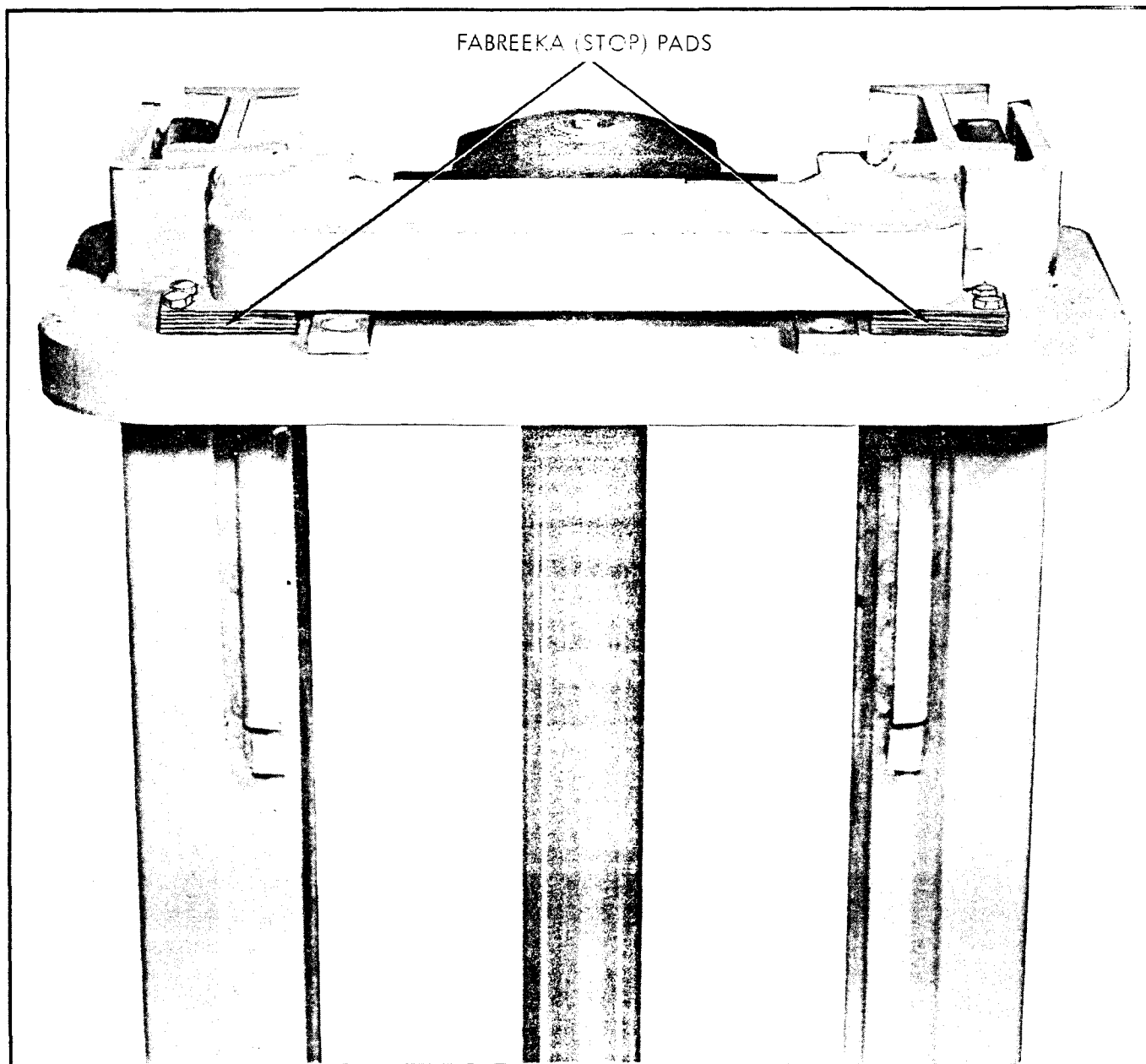

Plate 6619. Inner Slide Must Contact Both Fabreeka (Stop) Pads
At The Same Time When Lowering Inner Slide

OUTER RAIL ROLLERS

SHOULD BE CHECKED FOR ROLLER CLEARANCE THE FULL LENGTH OF THE INNER SLIDE RAIL.

CHECK INNER SLIDE BOTTOM ROLLER

IN THIS 10 TO 20 INCH SECTION OF THE OUTER RAIL.

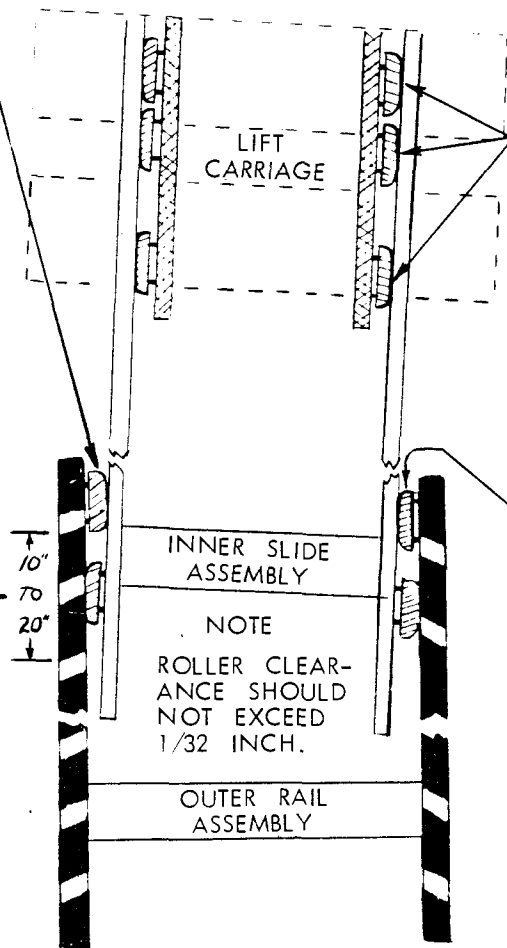

LIFT CARRIAGE ROLLERS

SHOULD BE CHECKED FOR ROLLER CLEARANCE THE FULL LENGTH OF THE INNER SLIDE RAIL.

OUTER RAIL ROLLERS

SHOULD BE CHECKED FOR ROLLER CLEARANCE THE FULL LENGTH OF THE INNER SLIDE RAIL.

NOTE
ROLLER CLEARANCE SHOULD NOT EXCEED 1/32 INCH.

NOTE

IF UPRIGHT RAILS ARE COCKED IN POSITION AS SHOWN, AND IF CLEARANCE IS CHECKED ON THIS SIDE, CLEARANCE IS MEASURED BETWEEN THE UPPER EDGE OF THE ROLLER RIM AND CORRESPONDING RAIL.

NOTE

IF UPRIGHT RAILS ARE COCKED IN POSITION AS SHOWN, AND IF CLEARANCE IS CHECKED ON THIS SIDE, CLEARANCE IS MEASURED BETWEEN THE LOWER EDGE OF THE ROLLER RIM AND CORRESPONDING RAIL.

LUBRICATION AND PREVENTIVE MAINTENANCE

UPRIGHT ROLLER ADJUSTMENTS.

NOTE

THE UPRIGHT OUTER RAIL ASSEMBLY IS MANUFACTURED WITH A SLIGHT TAPER, THE BOTTOM BEING 1/16 INCH WIDER THAN THE TOP. EXTEND THE UPRIGHT TO THE UPPER LIMIT. CHECK TO BE SURE THERE IS NO BIND. LOWER UPRIGHT. IF THERE IS A BIND, THE INNER SLIDE WILL HESITATE OR REMAIN AT THE UPPER LIMIT. AS THE LIFT CYLINDER BEGINS TO RETRACT, THE INNER SLIDE WILL BREAK FREE AND THEN LOWER. THIS INDICATES IMPROPER ADJUSTMENT, OR THIS MAY INDICATE A DAMAGED ROLLER WHICH WILL NOT ROTATE. RAISE AND LOWER CARRIAGE AND CHECK TO BE SURE ALL ROLLERS ROTATE FREELY.

1. Because of the 1/16 inch taper in the Outer Rail Assembly, the rollers may bind when upright is extended if roller adjustment is made with the upright lowered; therefore, the upright must be extended to the upper limit (with no backward or forward tilt) before making any adjustments.

2. Insert pry bar between bottom end of either right or left Inner Slide (Rail), and Outer Rail, refer to Plate 6891.

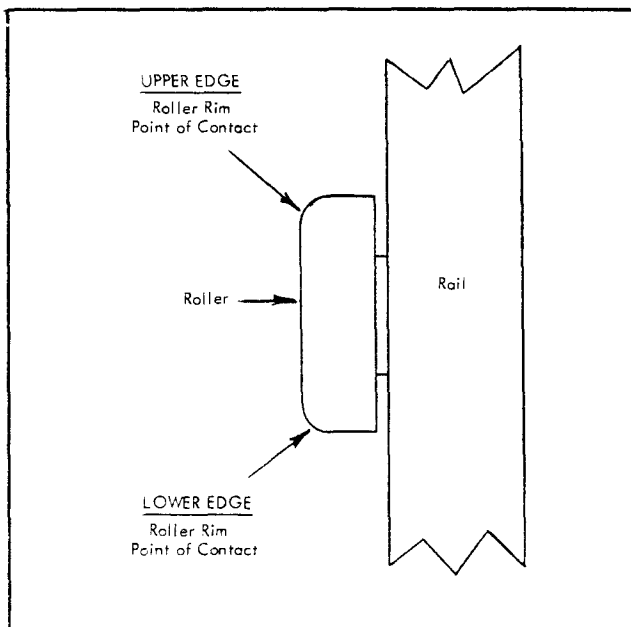

Plate 6325. Upright Roller

3. Move Inner Slide sideways to remove all clearance at opposite rail.

4. When checking clearance on the side that pry bar was installed, there must be some clearance between the Outer Rail and the bottom roller at the lower edge of the Roller Rim. THIS CLEARANCE SHOULD NOT EXCEED 1/32 INCH. If clearance is checked on opposite side, clearance should be checked between Outer Rail and bottom roller at the upper edge of Roller Rim, refer to Plate 6891 and 6325.

NOTE

THE BOTTOM ROLLERS OF THE INNER SLIDE, MUST BE CHECKED FOR CLEARANCE IN A 10 TO 20 INCH SECTION STARTING AT TOP OF OUTER RAIL ASSEMBLY, SEE Plate 6572.

5. Check clearance between Outer Rail Upper Rollers and Inner Slide. ROLLER CLEARANCE SHOULD BE CHECKED THE FULL LENGTH OF THE INNER SLIDE ASSEMBLY. Refer to Step 4 for Roller Clearance Specifications.

6. If adjustment is required, proceed as follows:

7. Disassemble upright.

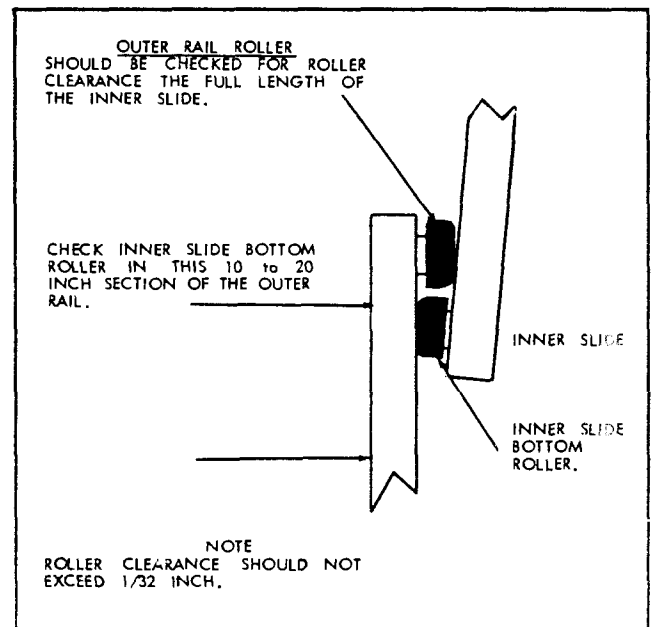

Plate 6572. Outer Rail Roller Clearance Check



INDUSTRIAL TRUCK DIVISION



LUBRICATION AND PREVENTIVE MAINTENANCE

8. Remove rollers from shafts and add or remove shims to acquire the clearance previously stated.

N O T E

THE ROLLER SHAFTS ARE WELDED TO THE RAIL ASSEMBLIES. TO REMOVE ROLLERS, MERELY PULL ROLLERS FREE OF ROLLER SHAFTS.

9. Reassembly upright.

10. Follow Steps 1 thru 5 and recheck clearance.

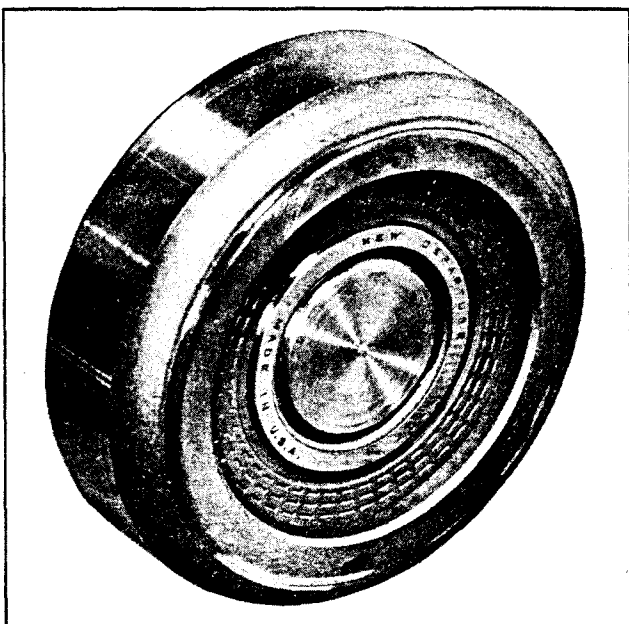

Plate 6323. Upright Roller

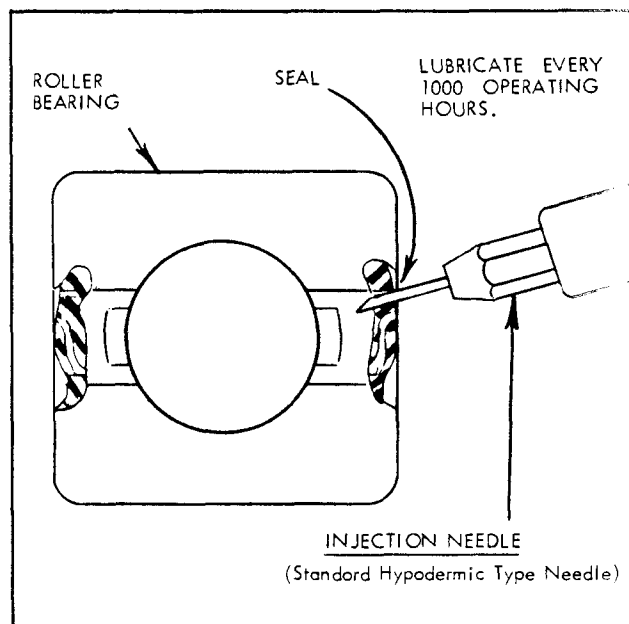

Plate 6328. Roller Bearing Lubrication

UPRIGHT AND CARRIAGE ROLLER LUBRICATION

The manufacturer does not recommend removing a bearing seal for periodic lubrication.

Bearings are generally provided with four openings (on the bearings front face, between the waffle pattern) for lubrication with an Injection Needle.

This needle is a standard hypodermic type needle and can be purchased in drug stores, refer to Plate 6328.

A good light petroleum base oil should be used.

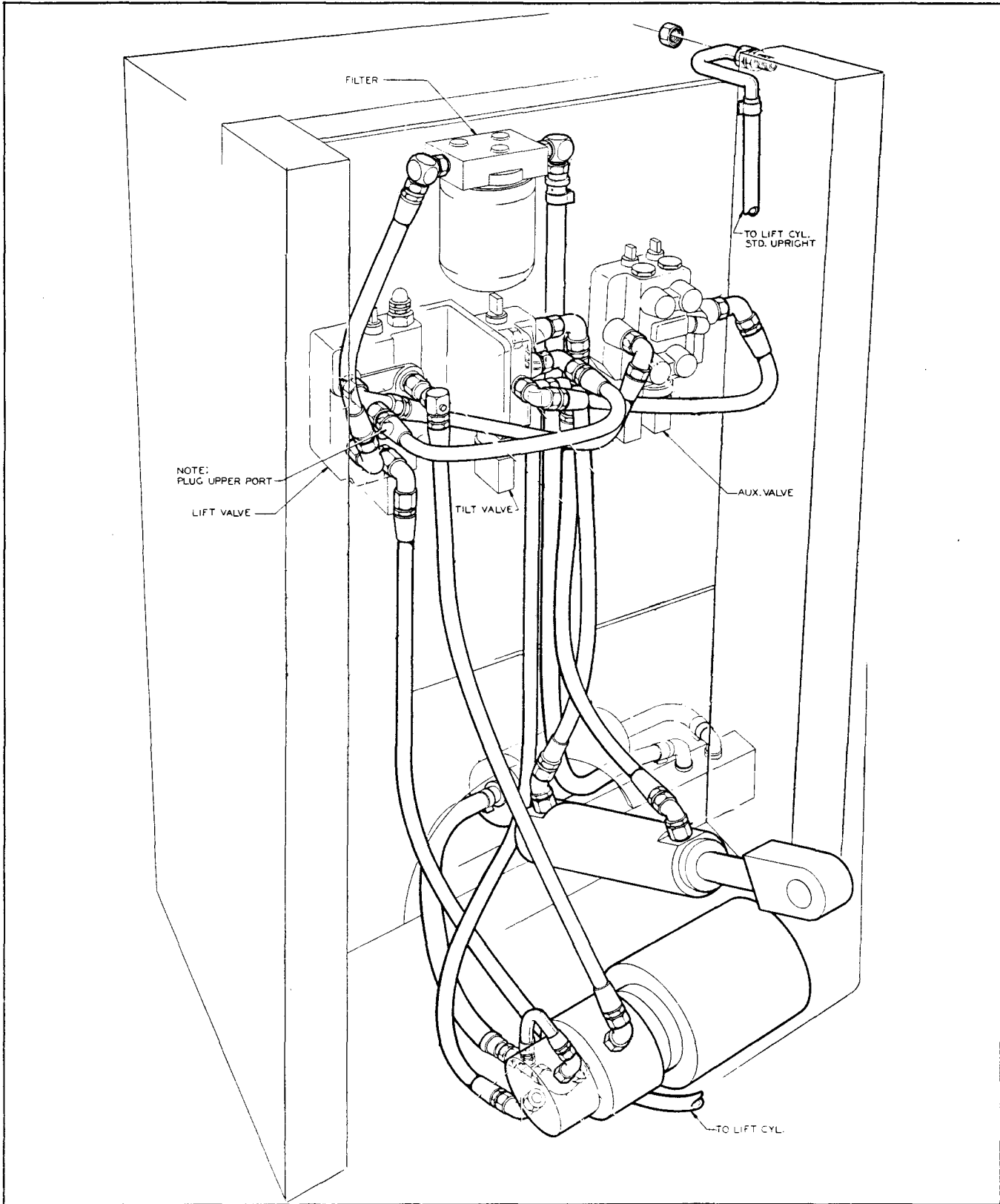

NST Hydraulic Circuit Diagram

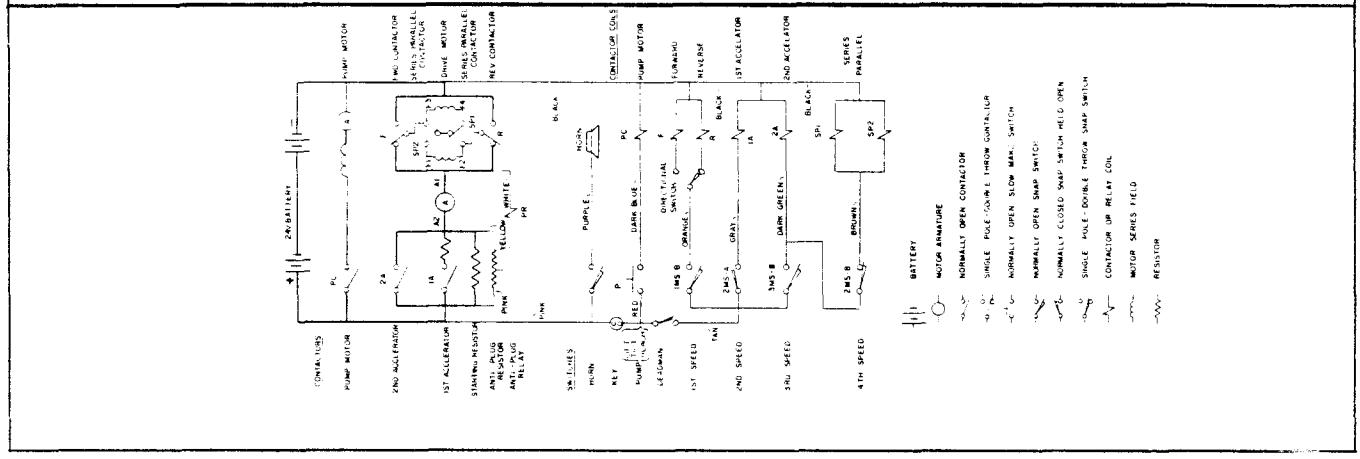
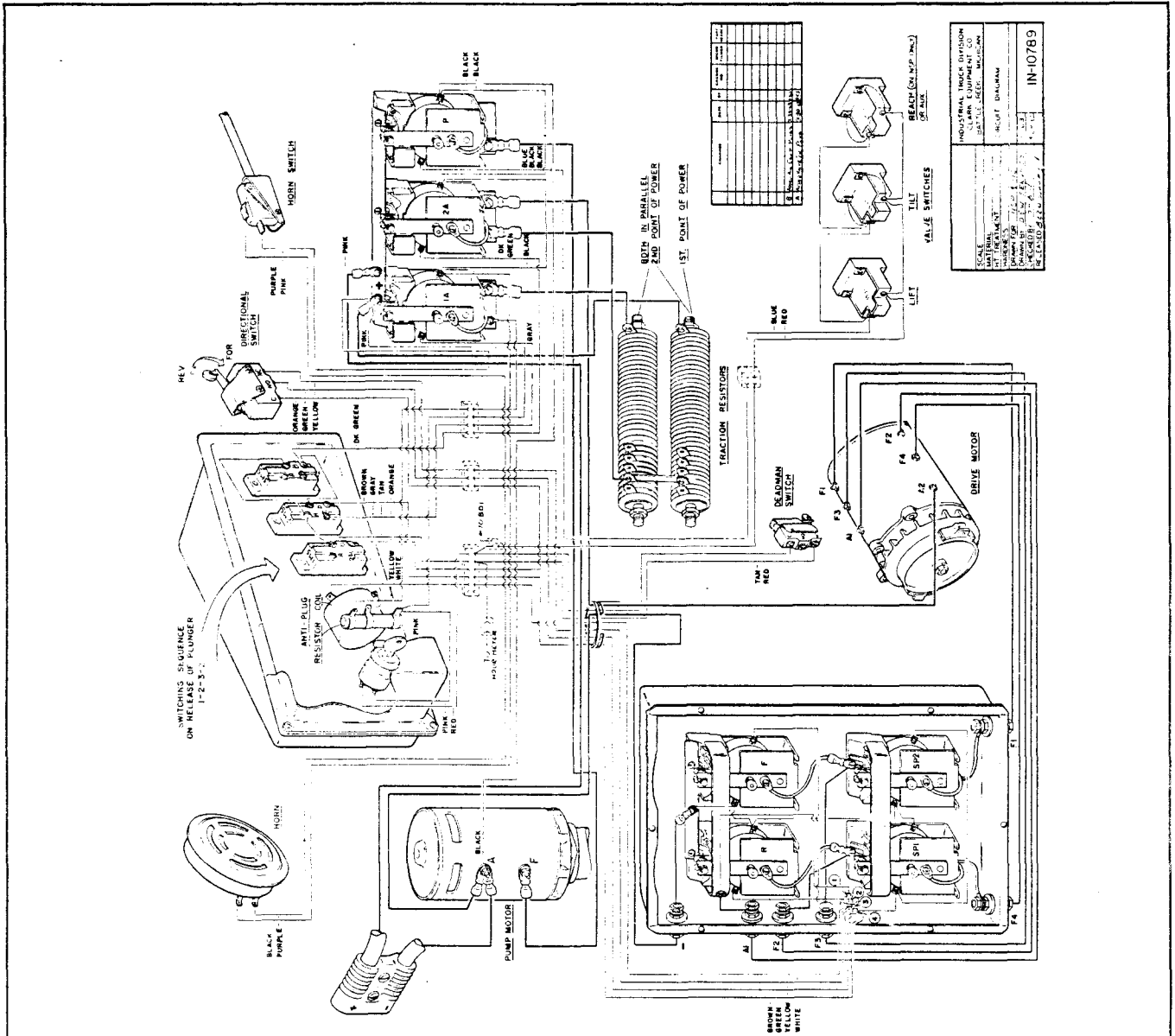





INDUSTRIAL TRUCK DIVISION



TROUBLE SHOOTING

CHECKOUT PROCEDURE FOR GENERAL ELECTRIC SOLID STATE (S.C.R.)

(Refer to the following Z pages for wiring diagrams --- 1063-Z and 1064-Z)

CAUTION

DO NOT USE MOTOR GENERATOR AS POWER SUPPLY - USE BATTERY ONLY. DO NOT USE HIGH VOLTAGE TESTER ON ANY SOLID STATE COMPONENTS, AS EXCESSIVE VOLTAGE WILL CAUSE PERMANENT DAMAGE TO THESE PARTS.

Power Wiring

The following tests are made with the battery connector removed from the truck connector receptacle. Visually check power wiring for correctness, tightness; check for potential short circuits and clearance of terminals to other live parts.

1. Prior to beginning of the test, the specific gravity of the battery should be tested. THE BATTERY SHOULD BE FULLY CHARGED AND THE SPECIFIC GRAVITY 1250 OR HIGHER.

CAUTION

DO NOT USE A GENERATOR AS A SOURCE OF POWER - MUST USE BATTERY

2. With a voltmeter set on 50 V.D.C. scale, check the polarity of the battery to the battery connector, making sure the positive (+) side of the battery is connected to the positive (+) side of the connector. You should have no voltage reading if polarity of battery to connector is correct.

3. With an ohmmeter (scale RX1) use red lead (+) to the positive side of the truck battery connector; the black lead to the 1FU amp fuse. Should have no (0) resistance.

4. The black lead (scale RX1) to the negative side of the truck battery connector; the red lead (+) to the PS2 of the pump motor. Again no (0) resistance.

5. With 1A contactor held closed and with an ohmmeter set on the RX10,000 scale check from both the positive and negative battery connection mounted on the truck to various points of the frame of the truck. NO READING OF LESS THAN 50,000 OHMS IS ACCEPTABLE ON NEW MACHINE FOR PROPER RESULTS OF THIS GROUND TEST.

Control Wiring: (Disconnect Battery & Discharge Capacitor 1C)

Check Control Wiring Using Ohmmeter.

6. With all switches open, measure 1500 ohm (to infinity) between 2 (+) and 13 (-).

7. Close key switch, deadman switch, and manually close directional switch and measure 30 or more ohms between wires 2 (+) and 13 (-). (RX1 scale). (Remove back-up light wire (if used at rev. contactor.) Repeat above check with the direction switch to reverse.

Accelerator Wiring: (Battery disconn.)

To check connections of accelerator switch:

8. Disconnect control plug from S.C.R. panel and measure 5,000-6,000 ohms between wires 29 and 13 (-) as fwd. or rev. switchette operates when control is moved slightly.

9. Measure 200 ohms or less between wires 29 and 13 (-) as (1A) interlock operates when control has hit stop.

Performance: (Battery Connected)

Manually check operation of all contactors to insure freedom from binding or interference with wiring.

Make the following voltage test with the pump contactor and the forward and reverse contactors isolated with a piece of cardboard between power tips prior to connecting the battery. Disconnect wire #45 at terminal strip on S.C.R. panel to isolate "1A" contactor. Connect battery with pedal down and key on.

10. With insulator in normally open power tip gaps of contactors, electrically operate F & R. Check the directional interlocking by holding F (or R) contactor amature in manually.



INDUSTRIAL TRUCK DIVISION



TROUBLE SHOOTING

11. Remove insulator from F & R contactors and close directional switch. Adjust creep speed on Card 1 as desired. Approx. 1 RPM of drive wheel.

With drive wheel jacked up and a jumper connecting wire #29 of TP (Thermal Protector) to the negative terminal (-) of S.C.R. panel, check maximum speed voltage and current limit. These adjustments have been preset at the factory and should not require adjustments.

NOTE

The above connection produces maximum S.C.R. speed immediately upon closing F (or R) switchette.

Material required to check current limit:

- Volt Meter with 50 V.D.C. scale.
- 600 amp 50 MV shunt.
- 50 MV Ammeter with 600 amp scale.
- Battery, fully charged (1250 sp. gr. min.) of amp hr. capacity equal to or greater than intended for use on machine.

Connect the shunt and ammeter in the positive lead between the battery connector and the truck receptacle.

Connect the volt meter between the positive terminal and T2 on the S.C.R. panel.

12. Check maximum speed voltage first by moving the accelerator to the forward or reverse position and applying the brakes until battery current is 60 to 70 amperes. Volt meter reading should be 16-18 volts. If not, adjust the top speed potentiometer on Card #1.

13. Now check current limit by moving the accelerator to the full power position and applying the brakes until the wheels come to a standstill. There must be no rotation of drive wheel for this check. The meter should read between

190 Amps Minimum - 210 Amps Maximum.

If not, adjust current limit potentiometer on Card #1.

NOTE

Do not stall motor for more than 30 seconds at a time. Allow time for motor cooling between stalls. Do not operate motor at high speeds or reverse motor with the wheels jacked up.

Operation:

14. Reconnect wire #45 and check 1A contactor pick up time for approximately 1 sec. With wheels on the ground, give truck a general operational check out, including plugging without load from various speeds. Adjust plugging distance with trippot on Card #1 as desired (CW to decrease distance).

NS/NSP/NST (General Electric Solid State Control
Contactors Specifications - F, R, 1A, & Pump -
100 Amp - 24 V.D.C.

Because of the contactor design, no adjustments are necessary. The normally open contact gap will be 5/16" plus or minus 1/16" and the normally closed gap will be 7/32 plus or minus 1/16".

The force required to separate the normally closed tips is 4 oz. (measured at tips).

The force required to separate the normally open tips is 1-3/4 pounds (measured at tips).

The force required to seal the normally open tips is 4-1/2 pounds (measured at the armature).

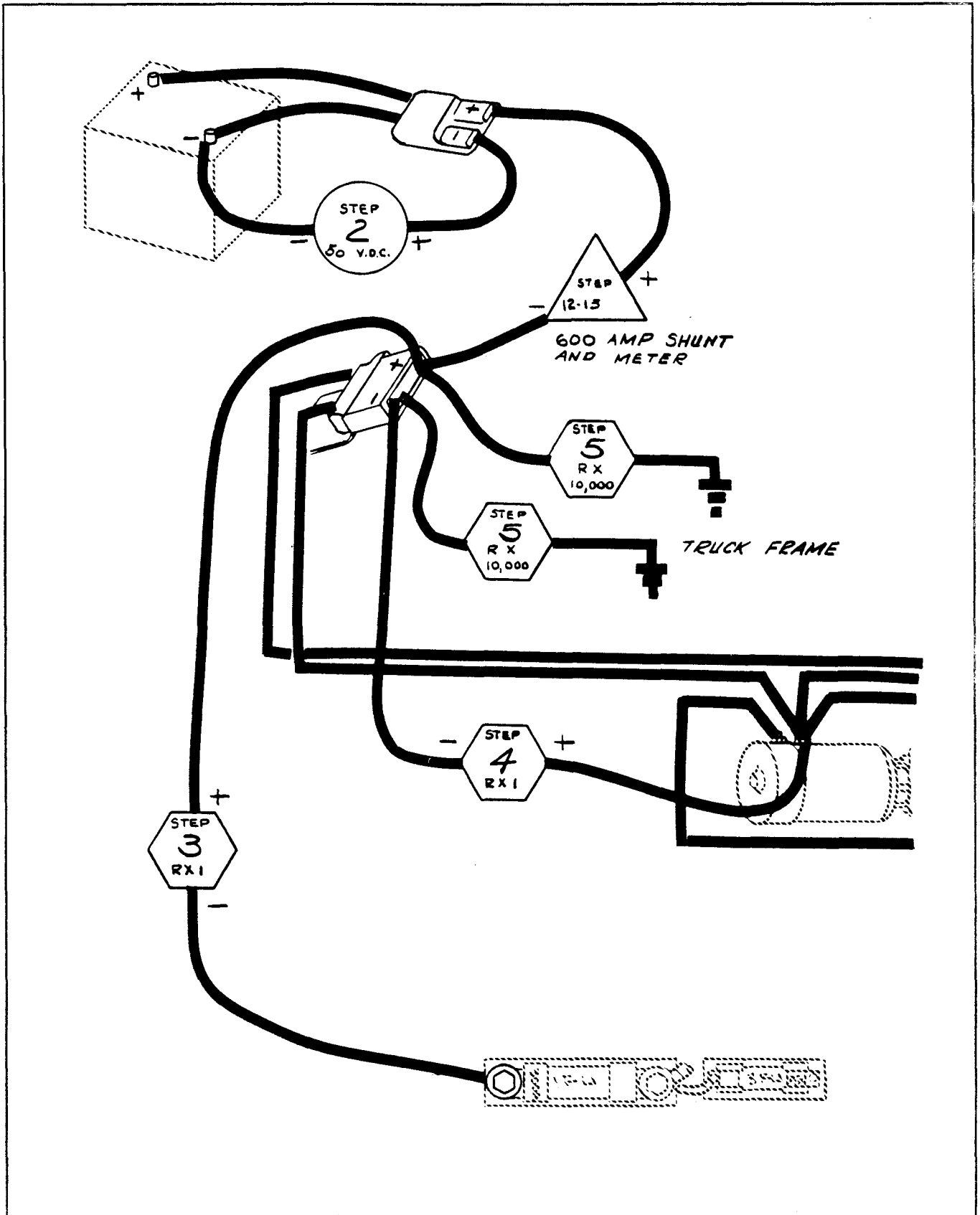

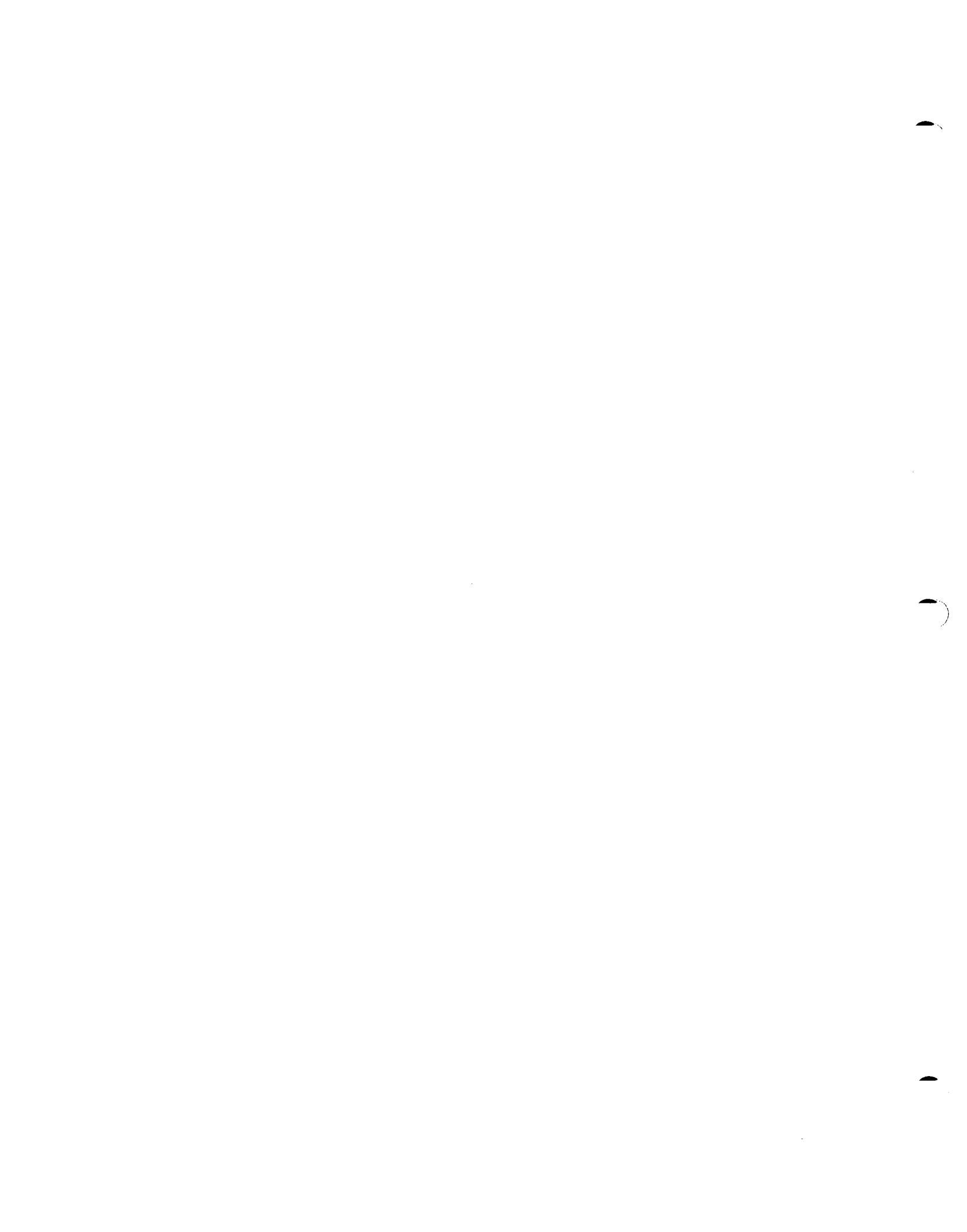

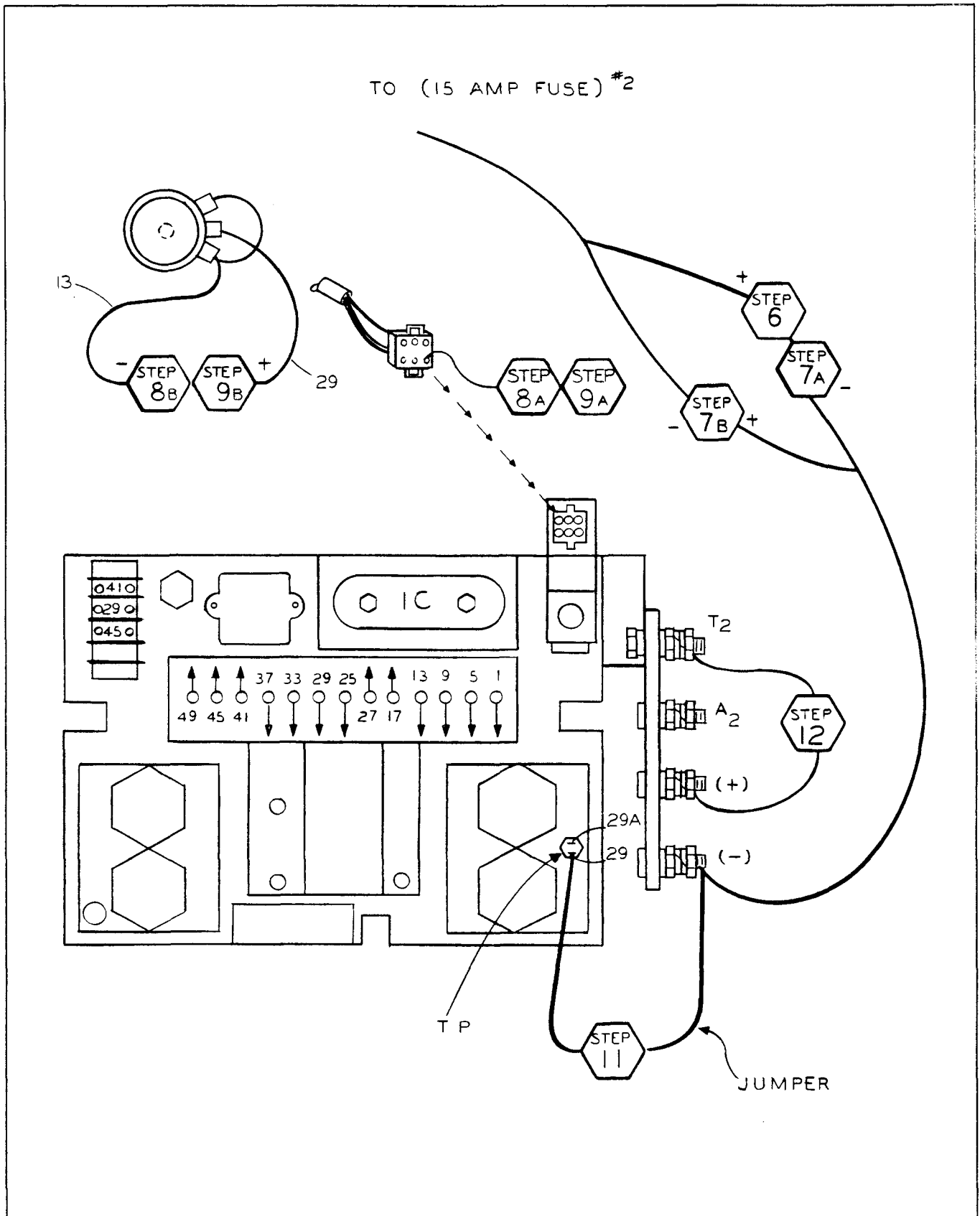



INDUSTRIAL TRUCK DIVISION



DEALER CHECK-OUT SHEET NS/NSP/NST

** General Electric - Solid State Control

Truck Serial No. _____ DATE _____

Power Wiring:

1. Battery voltage: (no load) _____ SP. GR. _____
2. Battery polarity checked? _____
3. Positive lead to 1FU checked? _____
4. Negative lead to PS2 checked? _____
5. Ground tests: (+) to frame _____ (-) to frame _____

Control Wiring: (Battery Disconnected)

6. Term's 2 (+) to 13 (-) (all switches open) _____ (Res.)
7. Term's 2 (+) to 13 (-) (deadman, key, Fwd. closed) _____ (Res.)
Rev. closed) _____ (Res.)

Accelerator Wiring: (Battery Disconnected)

8. Term's 13 to 29 (when fwd. or rev. switch operates) _____ (Res.)
9. Term's 13 to 29 (when "1A" switch operates) _____ (Res.)

Performance: (Battery Connected)

10. Fwd., Rev., 1A Contactors - Contactors and Interlocks checked? _____
11. Inching frequency checked? _____ (FPM)
(or RPM)
12. Maximum speed voltage
(Cables (+) to T2 on SCR panel at 60-70 amps) _____ (Volts)
13. Current limit reading _____ (Amps)

Operation:

14. Plugging distance _____ (Feet)

Mechanic _____ Hr. Meter Reading _____

OPERATING & MAINTENANCE

INSTRUCTIONS

SCR CONTROL for ELECTRIC VEHICLES

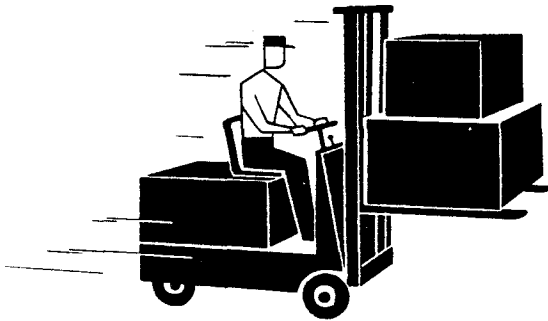

WHAT IS AN SCR?

Since the heart of the control is a silicon controlled rectifier (SCR), a general understanding of the characteristics of the device will be helpful. The SCR is a semi-conductor rectifier used as a latching switch; i.e., it may assume either a conducting or nonconducting state (On or Off).

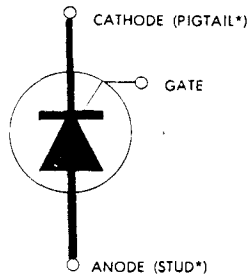

The SCR can be turned on by a momentary application of control current to the gate. To turn it off, it is necessary in addition to removing the turn-on signal from the gate, either to remove all power from the SCR or to apply momentary reverse voltage between cathode and anode.

* Typical of SCR as used in GE control for electric vehicles.

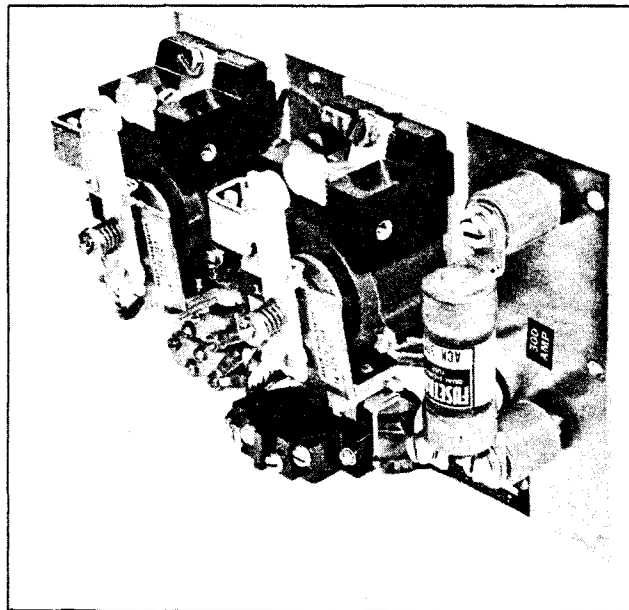

Figure 2 (9452)

Typical magnetic panel consisting of forward, reverse, bypass, and pump contactors.

PHOTOS OF CONTROL

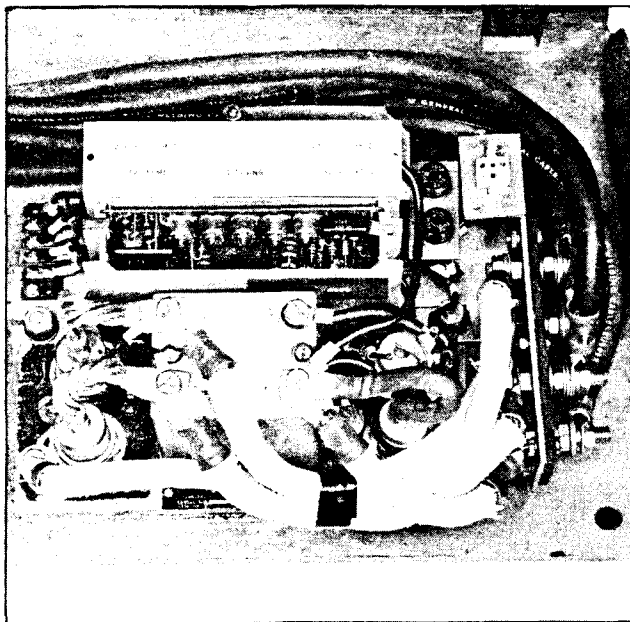

Figure 1 (9451)
Typical SCR static panel.

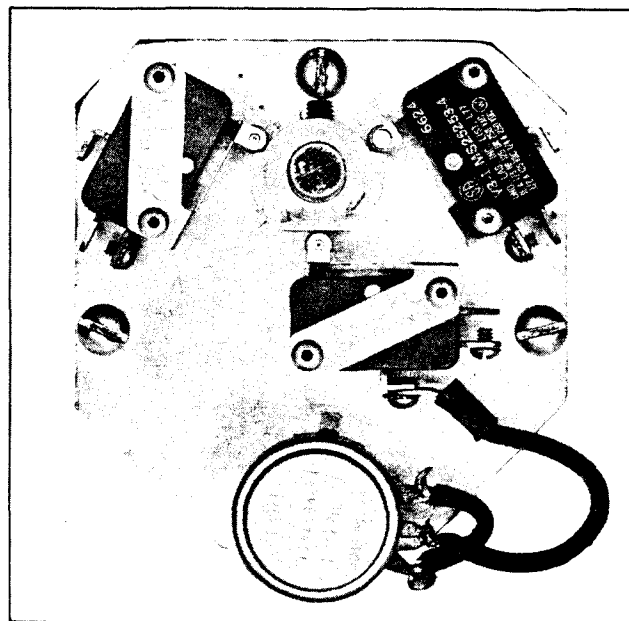
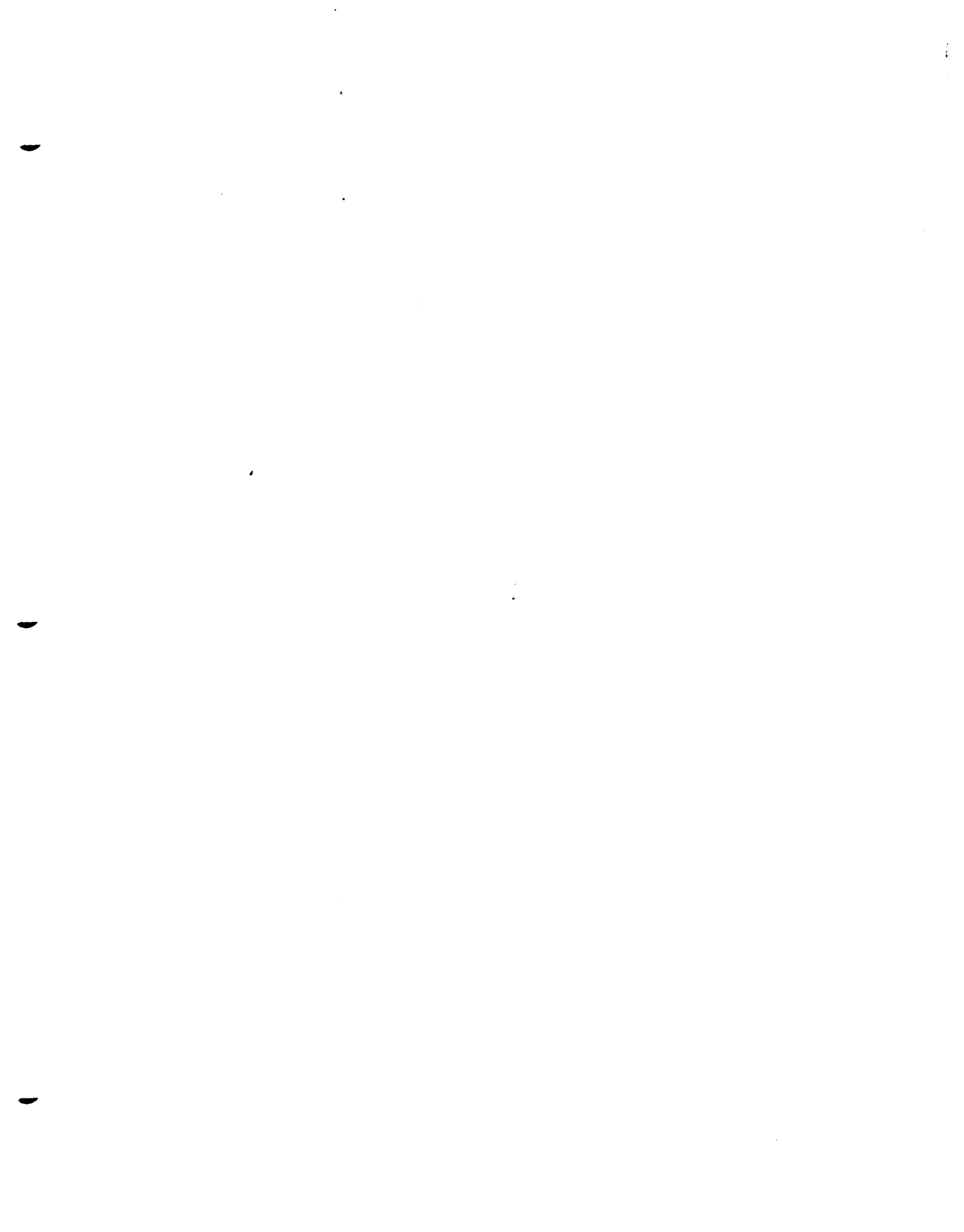
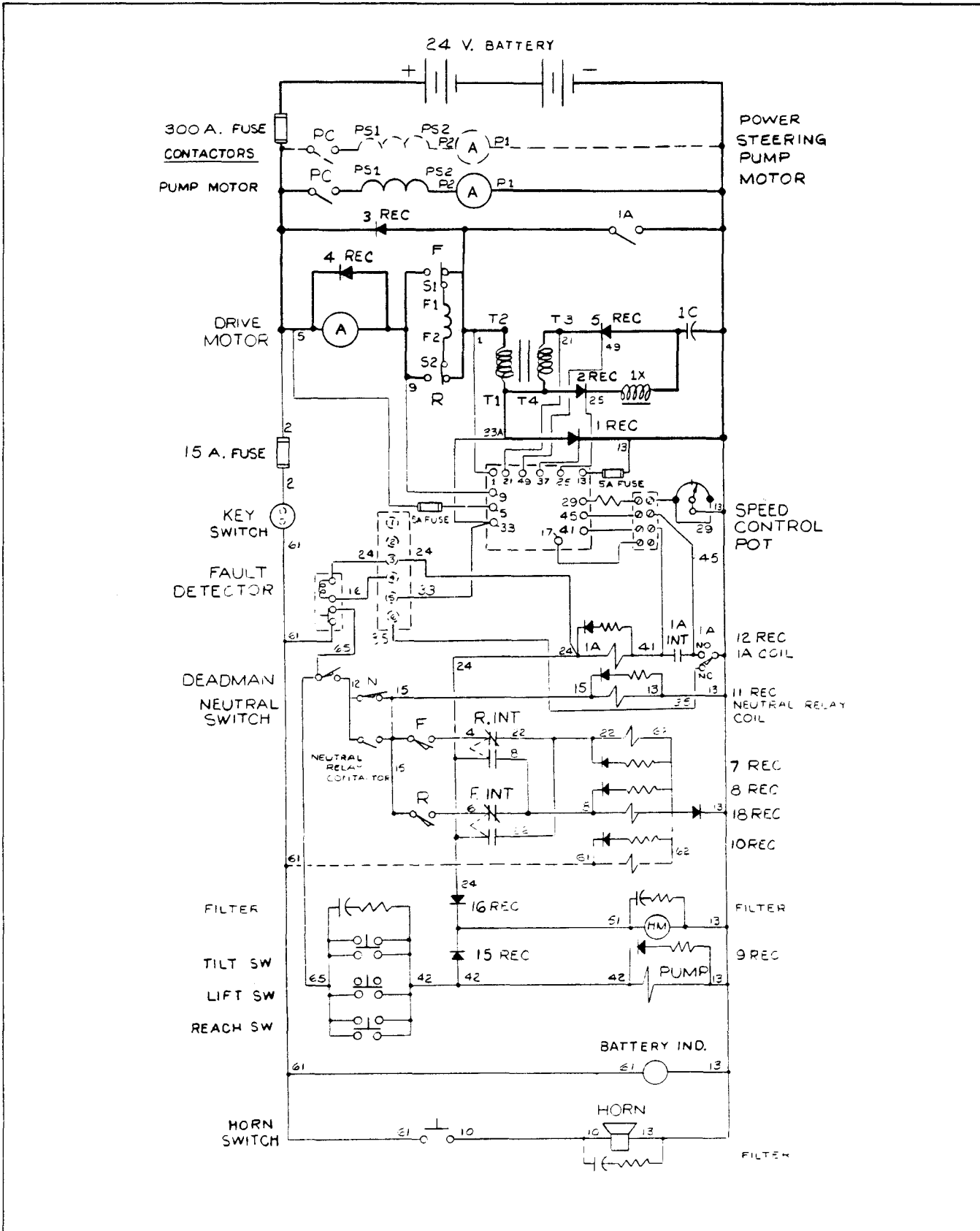

Figure 3 (9453)

Typical accelerator switch showing speed control potentiometer and control interlocks.



TROUBLE SHOOTING



CIRCUIT OPERATION (See Figure 4)

The circuit is energized by closing the key switch, the deadman (foot) switch, and moving the forward or reverse lever. The F or R contactor coil is now energized applying power to the drive motor circuit. Positive control power is fed through F or R interlock to wire 24 through the 1A coil to wire 41 to an oscillator located in Card 1.

The oscillator section will oscillate only when it receives both positive power through the F or R interlock and a synchronizing control signal from the anode of 1 REC (wire 33). The oscillator output is fed from terminal 37 to the gate of 1 REC, the main SCR. This is the gate signal which will switch 1 REC to the conducting state. When 1 REC is conducting, current flow is from battery positive through 1 FU, drive motor, T2-T1, 1 REC and back to battery negative. The initial rising d-c current through T2-T1 induces a voltage from T4 to T3, drives T3 below battery negative, causes current to flow from card 1 (wire 49) to the gate of 5 REC, turning 5 REC on. Current then flows from transformer secondary T4 through 1 REC, 1C, 5 REC and back to T3 charging 1C (wire 20) negative until the transformer saturates, reducing this current flow to zero, turning off 5 REC. The voltage of T3 then swings from negative to positive, causes current to flow from Card 1 (wire 25) to the gate of 2 REC, turning 2 REC on. 2 REC con-

ducts, capacitor 1C discharges around the circuit composed of 1C, 1 REC, 2 REC and 1X. This discharge current opposes the battery current through 1 REC so that the resultant current is zero. With reverse voltage across 1 REC (the main SCR), 1 REC is turned off.

This explanation has been for one complete cycle, or pulse, of circuit operation. Figure 5 illustrates the pulsing of current from the battery.

During the off time the energy stored in the motor, by virtue of its inductance, will cause current to circulate through the motor around the loop formed by 3 REC, thus providing what is called "flyback current." Figure 6 shows the nature of the motor current which is composed of both battery current and the inductive flyback current. It should be noted that the average motor current measured will be greater than the average battery current. The SCR control, in effect, converts battery current at battery volts into a higher motor current and a lower motor volts.

The time for the next cycle to start is determined by the time that the oscillator section of the card takes to oscillate. This frequency of oscillation is controlled by the potentiometer in the accelerator. Slow speed is obtained by having maximum ohms in the potentiometer. As the resistance in the pot decreases, the speed of the motor increases. With level operation, the SCR circuit is capable of delivering approximately 70-90% speed. For full-speed operation, the 1A contactor is closed to apply full battery voltage to the motor. 1A coil is energized by closing the 1A switchette in the accelerator.

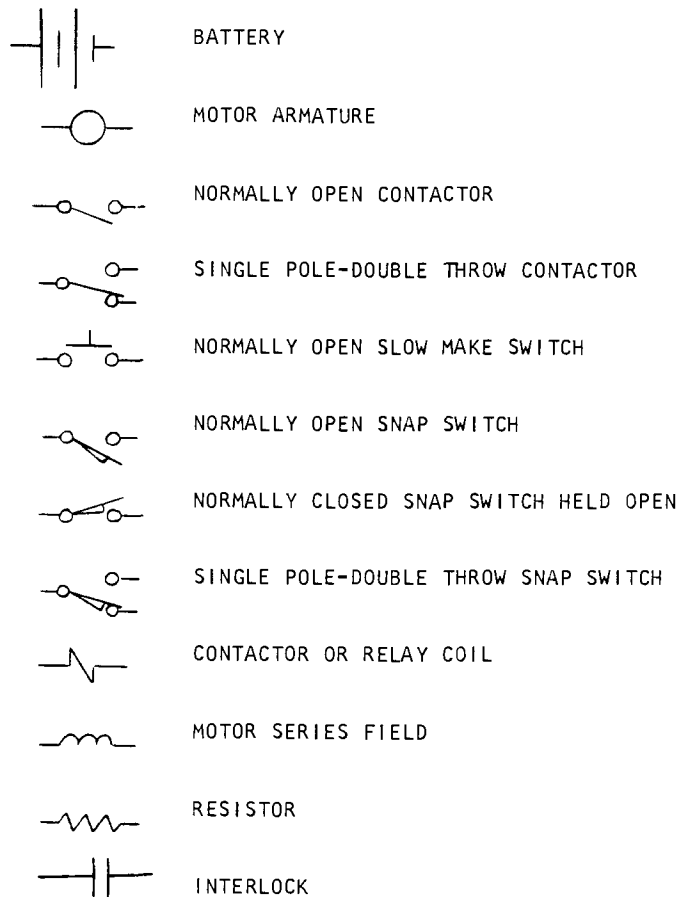

CARD 1

- **CURRENT LIMIT**—The current-limit section of Card 1 provides protection to the motor and control by limiting currents during acceleration and stall. This circuit is sensitive to load current and overrides the oscillator under heavy loads so as to limit the pulse frequency (thus the average current) to a value based on the maximum rating of 1 REC. Because of the flyback current through 3 REC, the motor current usually runs 2 to 3 times this current-limit value. The **CURRENT LIMIT** is adjustable by means of a trimpot on Card 1.
- **OSCILLATOR**—The oscillator section of the card has two adjustable modes and one fixed feature. With the accelerator pot at maximum resistance, the **CREEP SPEED** can be adjusted with a trimpot on the card. With the accelerator pot at minimum resistance, the **TOP SCR SPEED** is adjustable by means of a trimpot on the card. The fixed feature is controlled acceleration. When the accelerator is set for maximum speed and the directional switch is closed, the controlled acceleration provides a gradual buildup of pulses, thus giving a smooth acceleration to top SCR speed. This feature also provides a smooth re-acceleration during a plugging reversal of direction.
- **PLUGGING**—Slowdown is accomplished when reversing by providing a small amount of retarding torque for deceleration. If the truck is moving and the direction lever is moved from forward to reverse, the motor field is reversed. During the 1 REC off time the motor armature, driven by the inertia of the truck, acts as a generator. This generated current passes through 4 REC. A signal taken from 4 REC, when plugging current is present, is fed to Card 1 retarding the pulse frequency and provides a soft reverse stopping action. The distance or severity of the reversal is adjustable by means of a **PLUGGING** trimpot on the card.

- **1A TIMER**—A time-delay pickup of 1A is provided by a circuit in Card 1. This allows the truck to accelerate through the SCR range before 1A picks up even if the accelerator 1A switch is closed immediately. This time delay is adjustable by means of a 1A TIME trimpot on Card 1. An additional feature of the timer circuit is that 1A is rendered inoperative any time plugging is in process.

FAULT DETECTOR--Special features such as the fault detector is found in a separate publication:

(See page TS 855 & 856)

1A CONTACTOR (By-pass contactor around the SCR control)—The 1A contactor is used to provide top truck speed, torque, and efficiency when called for. The 1A contactor is picked up when the accelerator is moved to its extreme end of travel.

THERMAL PROTECTOR—A thermal protector (TP) is mounted on the heat sink between 1 REC and 2 REC. This is a temperature sensitive device which increases resistance with an increase in temperature. During the normal operating range, the thermal protector has a resistance of approximately 50 ohms. If the temperature of the 1 REC heat sink exceeds 80° C., the resistance of the thermal protector increases. Being in series with the accelerator potentiometer, this increased resistance decreases the speed of the truck. The truck will operate at a reduced speed until the temperature reaches a safe value, then full SCR power will be available.

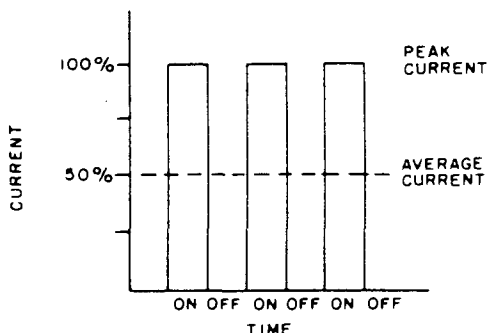

Figure 5—Battery Current

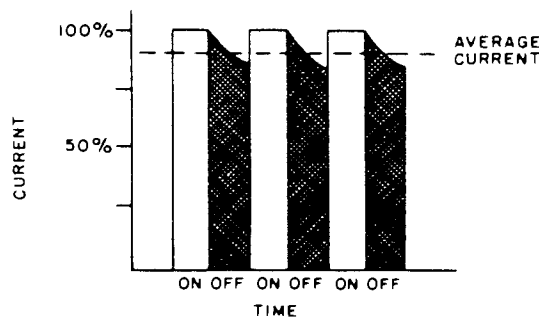

Figure 6—Motor Current



INDUSTRIAL TRUCK DIVISION



T R O U B L E S H O O T I N G

General Maintenance Instructions

The SCR control, like all electrical apparatus, does have some thermal losses. The semiconductor junctions have finite temperature limits above which these devices may be damaged. For these reasons, normal maintenance should guard against any action which will expose the components to excessive heat, such as steam cleaning; or which will reduce the heat dissipating ability of the control, such as restricting air flow.

The following DO'S and DON'TS should be observed:

- Any controls that will be used in altitudes of 5000 feet or over and in ambients of 100° F (40° C) or over should be brought to the attention of the truck manufacturer.
- The control should not be steam cleaned. In dusty areas, use low pressure air to blow off the control.

In oily or greasy areas, a mild solution of detergent or de-natured alcohol can be used to wash off the control and then blow completely dry with low pressure air.

- The heat sinks for the SCR's and diodes are specially painted to help dissipate heat. Care must be taken in not getting any foreign paint on these heat sinks.

- Terminal boards and other exposed SCR control parts should be kept free of dirt and paint which might change the effective resistance between points.

- The truck should not be plugged when the truck is jacked up and the drive wheels are in a free wheeling position. This can create excessive voltages that can be harmful to the control.

Trouble-Shooting Instructions

The pulsing of the main SCR is too fast for conventional instruments to measure. When the control is functioning properly, a low hum can be heard.

Malfunctions of the SCR will generally fall into one of two categories. They are either no power (Table 1) or full power (Table 2), when operating in the SCR control range.

These simple and easy-to-follow tables outline the various symptoms and the corrective action to be taken.

The same device designations have been maintained on different controls but the wire numbers may vary. Refer to the elementary and wiring diagram for your specific control. The wire numbers shown on the elementary diagram will have identical numbers on

the corresponding wiring diagrams for a specific truck, but these numbers may be different from the numbers referenced in this publication. All wire numbers will be preceded with a "G" to distinguish GE numbers from truck manufacturer's wires.

Before proceeding, visually check for loose wiring, maladjusted linkage to accelerator switch, signs of overheating of components, etc. Before touching electrical components, disconnect the battery and discharge capacitor 1C. Reconnect the battery as needed for the specific check.

Tools and test equipment required are 24-volt test battery, 25-ohm 2-watt resistor, 3-volt battery---3-volt lamp (or BRIGHT STAR No. 1618CT circuit continuity tester), clip leads, volt-ohm meter (20,000 ohms per volt) and general hand tools.



INDUSTRIAL TRUCK DIVISION



TROUBLE SHOOTING

Table 1

Failures Which Cause No Motor Torque With SCR Control

| SYMPTOMS | WHAT TO DO |
|---|--|
| 1A. Contactors do not pick up. No control voltage from positive to negative. | <ul style="list-style-type: none">● Check power fuses.● Check battery for low specific gravity and connections for looseness or broken fittings. |
| 1B. Contactors do not pick up. Control volts present from positive to negative. | <ul style="list-style-type: none">● (For these tests, disconnect wire 24 from fault detector terminal 3).● (See NOTE 1) Connect jumper from battery positive to positive side of F or R coil. If device does not pick up, check coil for continuity. Also jumper negative to opposite terminal to check for opens in negative connections.● (See NOTE 1) With jumper on battery positive move other end to wire 6 on F interlock or 4 on R interlock. Coils should pick up. This proves F and R electrical interlocks.● (See NOTE 1) Using jumper continue to check remaining components in circuit such as directional switch, deadman switch, and key switch by moving end of jumper to positive side of each of these devices. |
| 1C. Contactors close. No power and no SCR hum with accelerator in SCR range. | <ul style="list-style-type: none">● (See NOTE 1) With F or R picked up and wire 45 disconnected at SCR terminal board, check for control volts positive at SCR terminal board (wire 41) to negative (wire 13A). If there is zero volts at this point, check F or R normally open interlocks and 1A coil for continuity.● (See NOTE 1) With F or R picked up and wire 45 disconnected at SCR terminal board, check for control volts positive at 1 REC heat sink (wire 33) to negative (wire 13A). If there is zero volts at this point, check: FUB, F or R power tips, and continuity of wiring from battery positive to 1 REC heat sink. |

NOTE 1: Drive wheels should be off the floor.



INDUSTRIAL TRUCK DIVISION



TROUBLE SHOOTING

1C (Continued)

- (See NOTE 1) With F or R picked up and wire 45 disconnected from SCR terminal board, measure approximately 3 volts from (wire 29) to negative (wire 13A) with accelerator pot near creep speed. Volts will drop to zero as accelerator is moved toward full speed. If readings are not correct, first place a jumper wire between wires 29 and 29A which bypasses the thermal protector. Depress the accelerator and check for the above voltage. If voltage readings are correct, replace thermal protector.

If the above tests will produce no voltage change, place a jumper between wires 29A and 13A. This bypasses the accelerator and the truck should now run at top SCR speed. If top speed is obtained, check accelerator pot per Table 4I. If motor fails to operate, check card per Table 4A.

- Check 1 REC for open circuit or open gate (See 4H).
- Check card (See 4A).

1D. Contactors close, but very little power and high-pitch SCR hum.

- Check 2 REC for a shorted condition in the conducting direction (See 4H).

1E. Contactors close. Very little or no power with low SCR hum, even when accelerator is in top SCR position.

- (See NOTE 1) Disconnect wire 5A from 3 and 4 REC heat sink and wire 9 from F and R contactors. Reapply power and if control operates normally, replace card.
- (See NOTE 1) Check setting on card, creep speed and top speed. Also if current limit is full counter-clockwise speed will be slow.

1F. Contactors close. Very little power with a normal SCR hum.

- Check 3 REC for open condition (See 4G). If 3 REC is found to be open, check 1, 2, and 5 REC for proper operation.
- Check 4 REC for short (See 4G).

NOTE 1: Drive wheels should be off the floor.



INDUSTRIAL TRUCK DIVISION



T R O U B L E S H O O T I N G

Table 2
Failures Which Cause Full Motor Torque With SCR Control

| SYMPTOMS | WHAT TO DO |
|---|--|
| 2A. Contactors close. Full SCR speed immediately with audible hum. | <ul style="list-style-type: none">● Check potentiometer for proper resistance (see 4I).● Check for grounds in wires 29 and 29A or shorted accelerator pot. |
| 2B. Contactors close. Full speed immediately with no audible hum.* | <ul style="list-style-type: none">● Check for welded power tips on 1A contactor.● Check timer section of card (See 4Ad). |
| 2C. Contacts close. Full speed immediately with no audible hum.* <u>Capacitor not charged.</u> | <ul style="list-style-type: none">● Check for open gate circuit to 5 REC (See 4H and 4Aa).● Check 5 REC for shorted condition (see 4H). If 5 REC shorted, also check 4Ac.● Check continuity of wiring from 1C to 5 REC and from 5 REC through T3, T4 to T1 and 1 REC wire 33.● Check capacitor 1C (See 4D).● Check 1 REC for short (See 4H). |
| 2D. Contactors close. Full speed immediately with no audible hum.* <u>Capacitor Charged.</u> | <ul style="list-style-type: none">● Check for open 2 REC (See 4H).● Check for open gate in 2 REC (See 4H).● Check for open gate circuit to 2 REC (See 4Ab). |

* If truck is equipped with a fault detector and it fails to shut down the control on the above faults, check fault detector



INDUSTRIAL TRUCK DIVISION



TROUBLE SHOOTING

Table 3

Misoperation of Special Features

| SYMPTOMS | WHAT TO DO |
|---|--|
| 3A. Failure of 1A contactor to operate. | <ul style="list-style-type: none">● (See NOTE 1) With all direction switches closed, jumper negative to SCR terminal board (wire 41). 1A should pick up immediately. This checks the 1A coil.● (See NOTE 1) Move negative jumper to SCR terminal board (wire 45). 1A should pick up after approximately 1 second delay. This checks the timer section of Card 1.● If the two above tests check good, then check 1A switch in accelerator for proper operation. |
| 3C. Severe reversal. | <ul style="list-style-type: none">● Check settings of plugging trimpot on Card 1 (See 6b).● Check 4 REC (See 4G).● Check continuity of wires 5 and 9.● Check FUA (if used). |
| 3D. Very soft reversal. | <ul style="list-style-type: none">● Check same as 3C. |

NOTE 1: Drive wheels should be off the floor.



INDUSTRIAL TRUCK DIVISION



TROUBLE SHOOTING

Table 4 Checking Components

Before touching electrical components, disconnect the battery and discharge capacitor 1C.

4A CARD 1 (See Table 6 for tuneup of Card 1).

The following is a list of simple tests that can be performed with a volt-ohm meter. Remove card from panel by loosening two screws at bottom of box, pull box straight up to disengage from receptacle. Connection can be made to card pins with insulated clips.

a) 5 REC FIRING CIRCUIT:

VOM on RX100 scale. Connect VOM positive lead to pin 13, negative lead to pin 49, circuit should read 1700 to 2100 ohms. Reverse leads and read infinity.

b) 2 REC FIRING CIRCUIT:

VOM on RX100 scale. Connect VOM positive lead to pin 21, negative lead to pin 25; circuit should read 1170 to 1430 ohms. Reverse leads and read infinity.

c) TRANSFORMER FILTER:

VOM on RX100 scale. Connect VOM positive lead to pin 21, negative lead to pin 33; circuit should read 2050 to 2750 ohms. Reverse leads and read infinity.

d) 1A TIMER:

Connect volt-ohm meter positive to 41, negative to 45, and set scale to 50-volts d-c. Using a 24-volt test battery, connect battery positive through a 25-ohm 2-watt resistor to terminal 41. Connect battery negative through a normally open switch to terminal 45. Close switch and observe battery voltage on VOM, after approximately 1 second voltage should drop to 0 volts indicating timer action. Do not hold power on after timer turns on.

4C FAULT DETECTOR (See page TS 855 & 856)

4D CAPACITOR 1C

Disconnect battery and discharge capacitor. Remove Card . Measure ohms through the capacitor using the RX10,000 scale. Meter should read zero ohms and then swing to above 100,000 ohms. Replace capacitor if above reading is not obtained.

4E CONTACTORS F, R, 1A, AND P

(See page 100H 673.)

NOTE: Control is arranged so that F and R do not normally break current. Contactor 1A drops out ahead of F or R.

4F CONTACTOR COIL FILTER (7, 8, 9, 11 & 12 REC) (10 REC on power steering)

a) Filter. These are resistor - diode assembly (connected across all contactor coils) and should be checked as follows: Disconnect the leads to the filter block, Figure 7. If resistance should be approximately 100 ohms in the conducting direction and infinity in the opposite direction.

b) Refer to G.E. #4K.

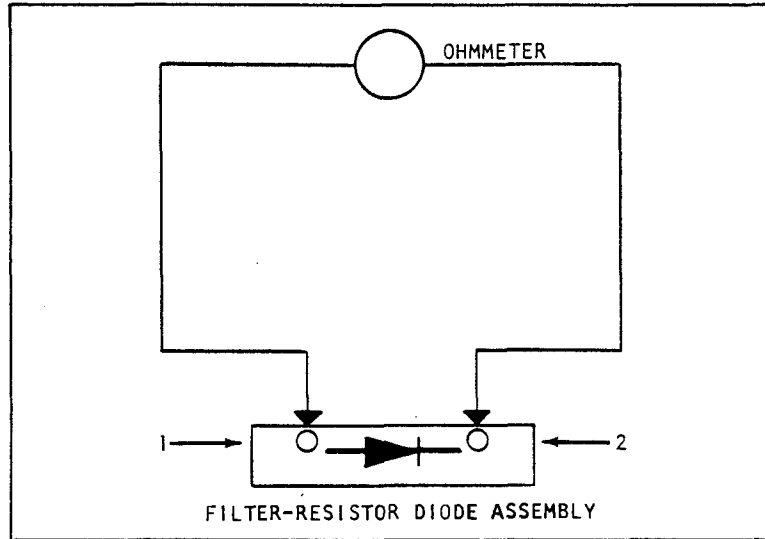

Figure 7.

4G RECTIFIERS

When checking diodes, disconnect battery and discharge capacitor 1C to prevent burning out the ohmmeter. When reassembling rectifiers, refer to Table 5.

3 and 4 REC: Disconnect pigtail. 3 and 4 REC are diodes with about 7 to 12 ohms in the conducting direction ($\overset{+}{\rightarrow}$) measured on the RX1 scale, and infinite resistance in the non-conducting direction ($\overset{-}{\leftarrow}$) measured on the RX10,000 scale.

15 and 16 REC: Disconnect one lead. Check same as 3 and 4 REC above.

4H SCR'S (1 REC, 2 REC, 5 REC)

These are silicon control rectifiers. Before checking, disconnect battery and discharge capacitor 1C. Remove card and box from panel and lay aside, this opens the gate circuits to all three devices. Disconnect pigtail of 1 and 2 REC or lead to terminal of 5 REC.

To check an SCR, it is necessary to have a 3-volt battery and a 3-volt lamp. (A test flashlight such as a BRIGHT STAR No. 1618CT circuit continuity tester is excellent for this test.)

Connect the plus lead to the stud (1), connect negative lead to the pigtail (3) as shown in Figure 8.

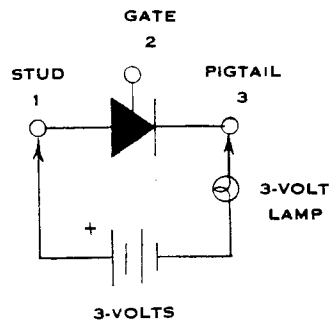

3-VOLTS
Figure 8

- a) The lamp should not light. If the lamp does light, the SCR is shorted and must be replaced.
- b) If check (a) was satisfactory, test the SCR for its ability to be turned on by the gate. Touch gate (point 2) to point 1. If gate is operative, the lamp should come on and must remain on when the gate is removed.
- c) If lamp cannot be lit under step (b) the SCR is open and must be replaced.

When reassembling SCR's, refer to Table 5.

4I POTENTIOMETER IN ACCELERATION

To check operation of the potentiometer, disconnect battery, and disconnect wire 29A from thermal protector or SCR Terminal Board. Connect VOM from wire 29A to negative (13) with scale set to RX100. With accelerator in neutral position, the ohm reading should be 6,250 ohms. With accelerator in top speed position reading should be 200 ohms or less. If these readings are not obtained, loosen pinion gear clamp and adjust rotation of pot shaft relative to accelerator shaft or replace. With wires disconnected as above, check for resistance of 1 megohm or higher from pot wires to truck frame.

4J THERMAL PROTECTOR (TP)

Remove both connections from TP and with a VOM read approximately 50 ohms terminal to terminal, if heat sink is at room temperature. Set VOM to highest ohm scale and check pins to heat sink, reading should be infinity.

4K FILTER BLOCK (HF)

Connected across hour meter, horn and valve switches. To check, disconnect all wires from filter block. With VOM on RX10,000 scale, touch the leads to the filter terminals to charge the filter. After a few seconds, reverse the meter leads and touch the filter terminals. The VOM needle will deflect and return to infinity. If this capacitor action is not observed, replace the filter block.



Table 5 Replacement of Semiconductors

When replacing semiconductors such as 1, 2, 3, 4 and 5 REC; it is not necessary to torque these devices to a specific value. However, the device should be screwed into the heat sink and tightened to a snug fit.

The use of a non-conducting grease (such as GE Versilube G-350-M or equivalent) is recommended.

Locking devices must be properly adjusted to prevent semiconductor from becoming loose.

Table 6 Tuneup for New or Mistuned Card 1

Panels are factory adjusted for a particular motor and truck and should not need adjustment when used with this motor and truck. However, touchup adjustments may be made without following procedure because these adjustments are so designed that they do not interact when near their proper setting.

If the panels are used to control motors or trucks for which they were not factory adjusted, the settings may be out of optimum adjustment to the extent that they do interact and procedure must be followed.

Before proceeding with tuneup, the following equipment is required:

500-ampere 50-millivolt d-c shunt

50-millivolt d-c meter (d'Arsonval movement)

50-volt d-c meter (d'Arsonval movement) (250-volt scale needed for 72V)

Battery with equal or greater ampere-hour capacity than used on truck, charged to 1200 or higher specific gravity.

Check that the ohms in accelerator potentiometer are less than 200 ohms in top SCR range (See Table 4I).

Jack up the truck so that the drive wheels are free to rotate.

Refer to Fig. 3 for potentiometer locations.

TUNEUP PROCEDURE

- a) Turn CURRENT-LIMIT adjustment fully clockwise.
- b) Turn PLUGGING adjustment fully clockwise. (Steps one and two prevent any interaction when setting the speed adjustment.)



INDUSTRIAL TRUCK DIVISION



TROUBLE SHOOTING

- e) Adjust CREEP SPEED as desired.
- d) To adjust TOP SCR SPEED, connect voltmeter between battery positive and T2 on the SCR panel. Remove wire 29 from the thermal protector and connect a jumper from wire 29 to negative (pigtail of 1 REC). If a brake interlock is used, short it out so that power and brakes can be applied at the same time.

Check top SCR speed by first moving the accelerator until the F or R contactor operate. Do not move accelerator to the point where 1A picks up.

Apply the brakes until battery current is about the loaded level amperes (approximately 70 amps) with motor directly across the battery. Adjust the top speed trimpot until the voltmeter reads between the following:

| BATTERY VOLTS | CURRENT LIMIT AMPS | MOTOR VOLTS |
|---------------|--------------------|-------------|
| 18 | 200 \pm 10% | 13-16 |
| 24 | 200 \pm 10% | 17-22 |
| 36 | 200 \pm 10% | 25-32 |
| 48 | 185 \pm 10% | 34-43 |
| 72 | 150 \pm 10% | 50-65 |

After the above setting is made, disconnect jumper, voltmeter and reconnect wire 29 on the Thermal Protector.

- e) To adjust CURRENT LIMIT, connect the shunt and millivolt meter between battery negative and 1 REC (or between truck receptacle and battery plug). Turn the current limit and plugging trim-pots fully counterclockwise. Remove wire 29 from the thermal protector and connect a jumper from wire 29 to negative (pigtail of 1 REC). If a brake interlock is used, short it out so that power and brakes can be applied at the same time. When the potentiometer is fully counterclockwise, the card is designed so that the control is cut off (no pulsing occurs).

Depress the accelerator until F or R operate but not the 1A contactor. Slowly turn the current limit potentiometer in a clockwise direction until the current reaches a value as shown in the above table. After setting to correct value, disconnect meter and reconnect wire 29 to the thermal protector.

NOTE: Do not stall the motor for more than 30 seconds at a time. Allow time for motor cooling between stalls. Do not operate motor at high speeds or plug the motor with wheels jacked up.

- f) Static Plug - turn PLUGGING control fully counterclockwise. With the truck on the ground, set static plugging for desired distance. (CW decreases plug distance.)

After all of the potentiometers have been set, each should be sealed with a silicon rubber compound such as RTV (bath-tub sealer). This will discourage further adjusting by unauthorized personnel.

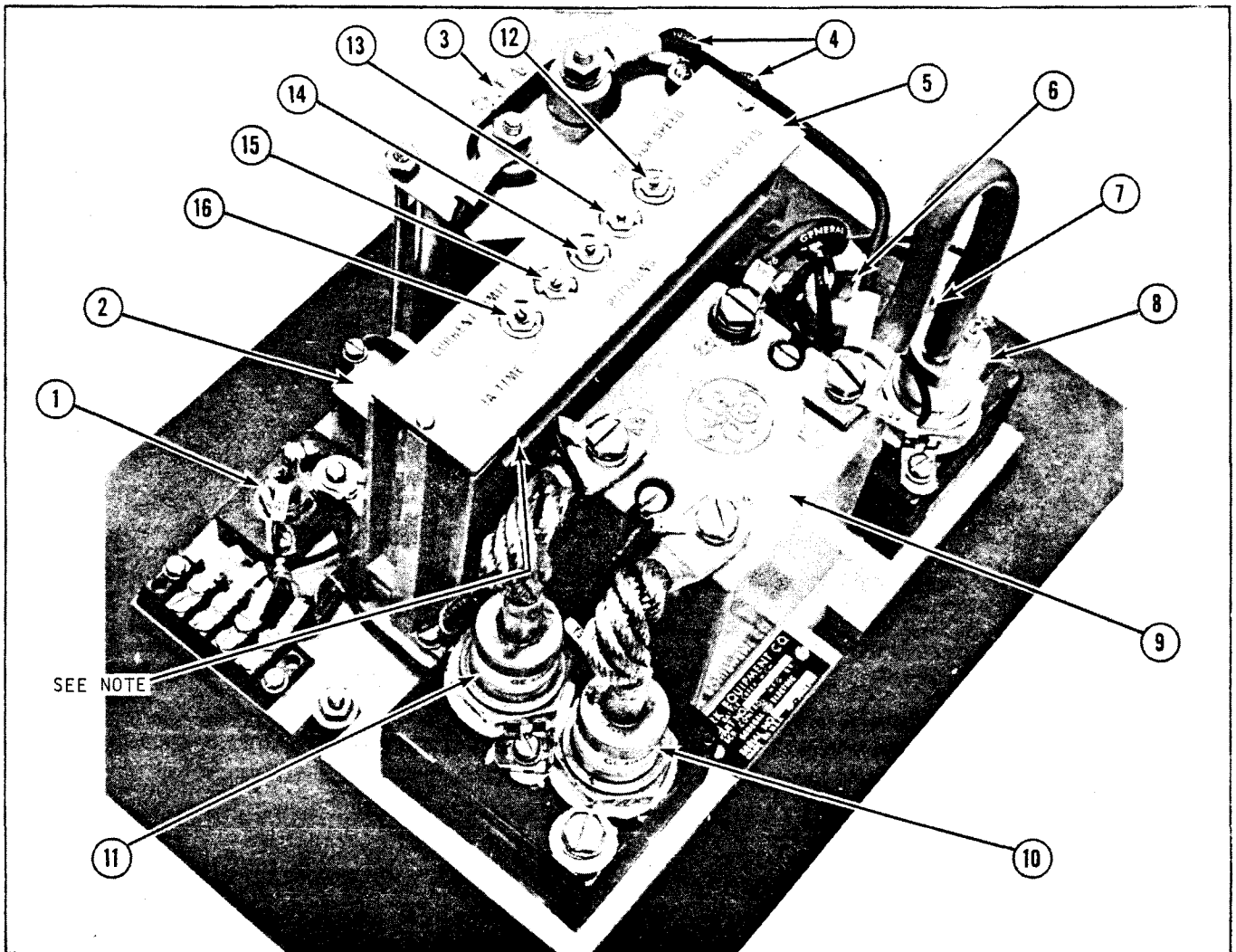

Plate 9457. Typical SCR Static Panel

- | | |
|---------------------------------------|-------------------------------------|
| (1)-----BLOCKING SCR (5 REC) | (9)-----PULSE TRANSFORMER (1C) |
| (2)-----CURRENT-LIMITING REACTOR (1X) | (10)-----FLY-BACK DIODE (3 REC) |
| (3)-----COMMUTATING CAPACITOR (1C) | (11)-----PLUGGING DIODE (4 REC) |
| (4)-----CONTROL CIRCUIT FUSES | (12)-----CREEP-SPEED ADJUSTMENT |
| (5)-----OSCILLATOR CARD (CARD 1) | (13)-----TOP-SPEED ADJUSTMENT |
| (6)-----TURN-OFF SCR (2 REC) | (14)-----STATIC-PLUGGING ADJUSTMENT |
| (7)-----THERMAL PROTECTOR | (15)-----CURRENT-LIMIT ADJUSTMENT |
| (8)-----MAIN SCR (1 REC) | (16)-----1A TIMER ADJUSTMENT |

N O T E

On earlier models, adjustment is made thru this slot. Do not remove cover or warranty will be void.

TROUBLE SHOOTING

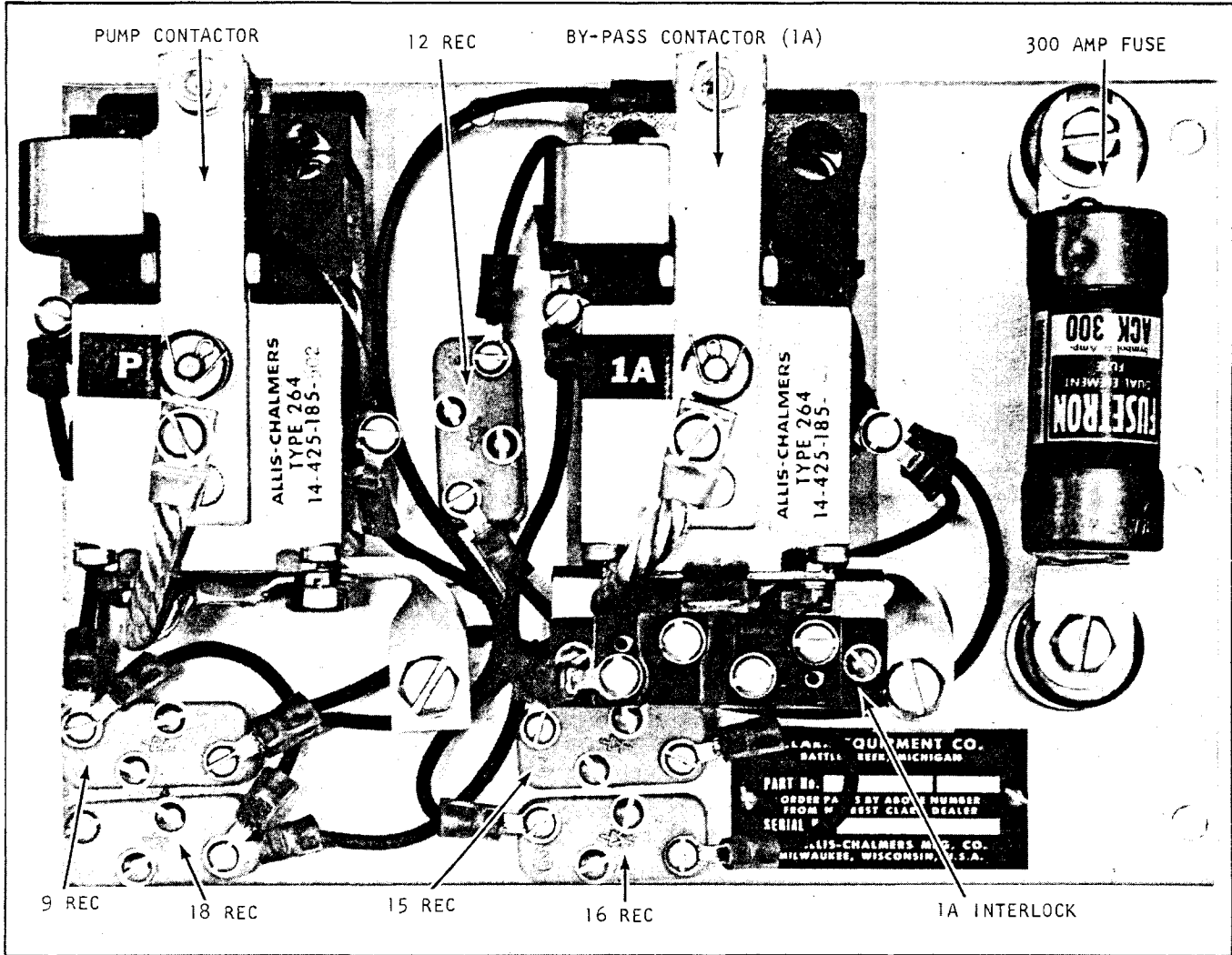

Plate 9454. Typical Magnetic Panel

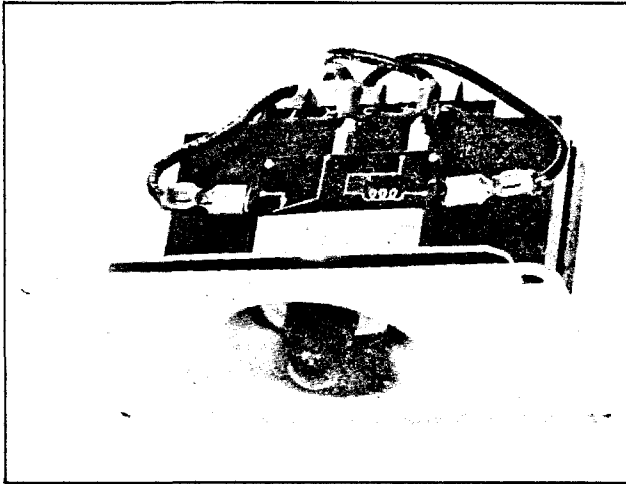

Plate 9458. Typical Fault Detector

FAULT DETECTOR (IC4484)

The fault detector is designed to shut down an SCR control on two types of faults as follows:

1) 1A Contactor Power Tips Fail To Open

When the truck is in 1A (top speed) the 1A switchette in the accelerator is open, giving the fault detector card no signal to terminal 5. When the accelerator is brought back into the SCR range the 1A switchette closes. If 1A fails to open, battery negative is applied to point 5 of the card through T2-T1 and if the fault does not clear with approximately 0.1 second, the circuit breaker trips, removing power by dropping out F or R contactor.

2) SCR Failure Which Causes Full Motor Torque

The SCR fails to pulse; it turns on and stays on continuously, causing essentially battery negative to be applied to point 5 of the card, similar to (1) described above. If such an SCR failure occurs the fault detector trips in 0.1 second.

TESTING

Jack the drive wheels up and operate the control in SCR range. Using an insulated tool, manually close 1A contactor and the fault detector should trip. If the fault detector fails to operate, check the following:

- a) Check 1A switchette in accelerator for proper operation.
- b) Remove the guard from the circuit breaker knob. Disconnect the wires from card points 1 and 2. Connect an ohmmeter to the circuit breaker contact points and manually operate the circuit

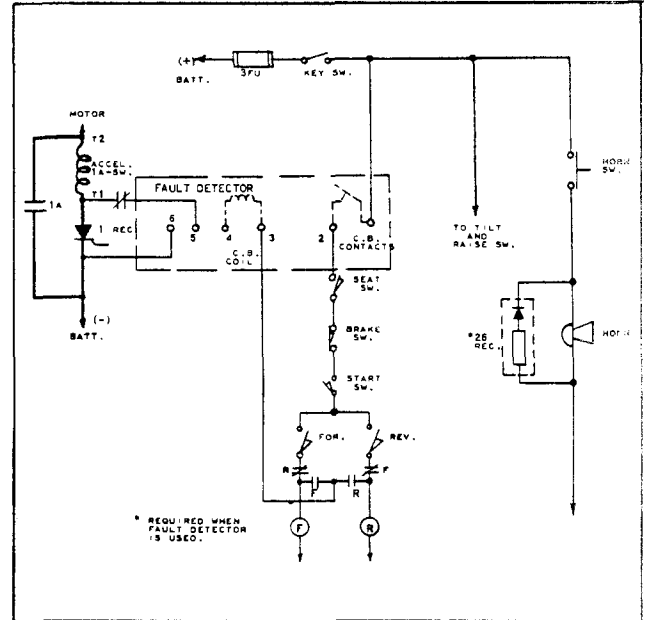

Plate 9459. Typical Circuit Showing Fault Detector

- breaker knob. The set position should read normally closed and the trip position should read normally open.
- c) Disconnect the wires from card points 3 and 4. Measure circuit breaker coil resistance, approximately 60 ohms.

If all tests are good and the fault detector still fails to operate, replace the card.

Check Out Procedure

If there should be nuisance tripping of the fault detector and all possible sources of the problem have been eliminated, perform the following checks on the card itself:

1. Disconnect all external leads on the fault detector.
2. Set ohmmeter on the RX10,000 ohms scale.
3. Check ohmmeter for zero with the test leads touching.

4. Perform resistance measurements on the card as designated below in which the typical values are shown:

(-) Negative lead on terminal No.

| | 3 | 4 | 5 | 6 | |
|-----------------------------------|---|-----|-----|-----|-----|
| (+) Positive lead on terminal No. | 3 | 0 | 1.6 | 3.0 | 2.3 |
| | 4 | 1.1 | 0 | 3.4 | 1.0 |
| | 5 | ∞ | ∞ | 0 | ∞ |
| | 6 | ∞ | ∞ | ∞ | 0 |

5. Manufacturing tolerances of plus or minus 10% variation from the above values are acceptable except the values of infinity (∞) should not be less than 200,000 ohms.

If the measured resistance values of the fault detector card do not fall within the above specifications, it may be assumed the card is faulty and should be replaced.

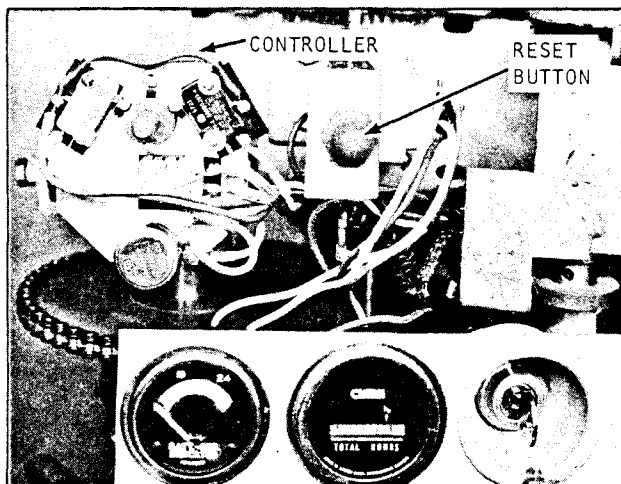

Plate 9490. Typical Fault Detector Reset Button

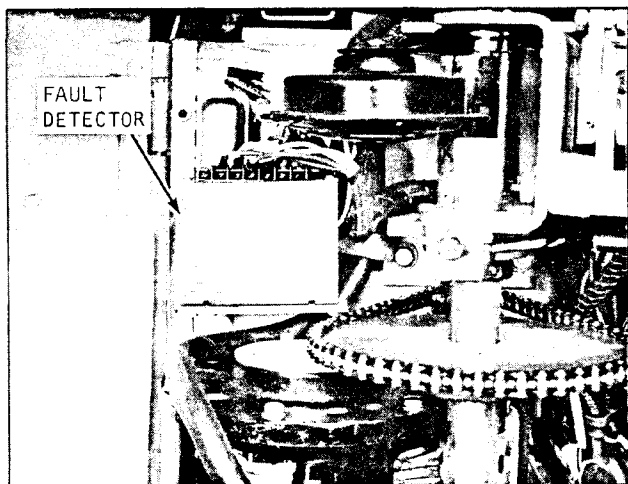
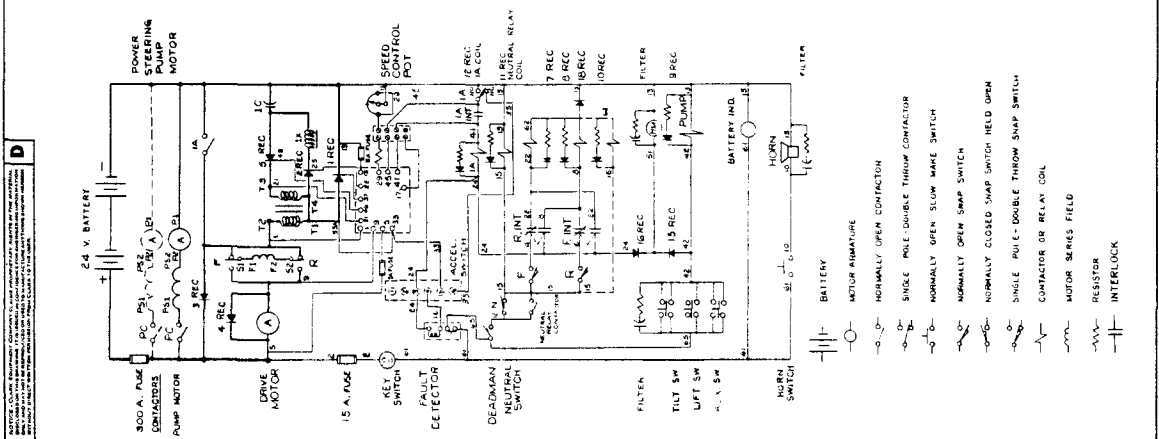
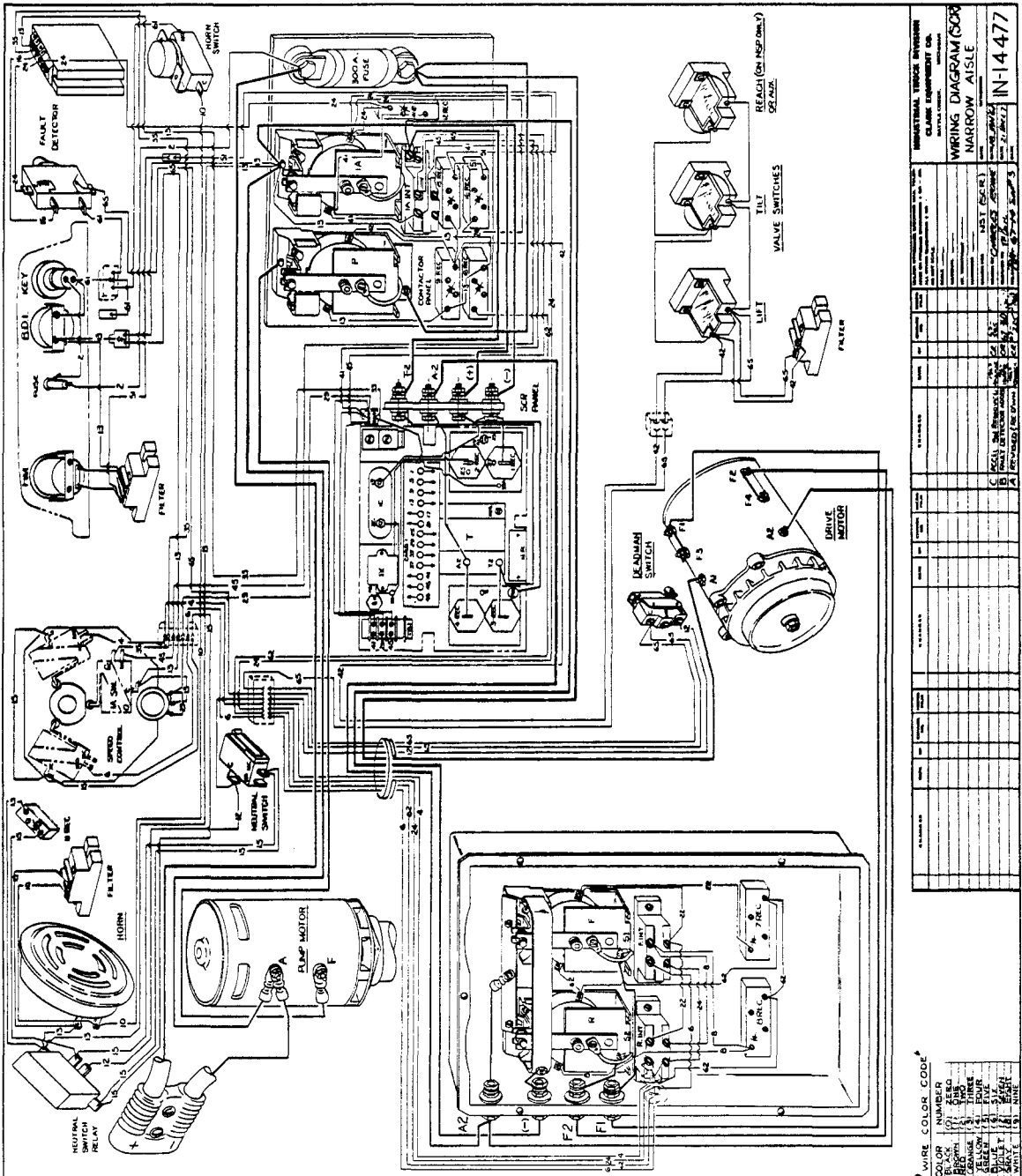

Plate 9489. Typical Fault Detector



WIRE COLOR CODE

| | |
|----|--------|
| 1 | RED |
| 2 | BLACK |
| 3 | GREEN |
| 4 | YELLOW |
| 5 | BLUE |
| 6 | PURPLE |
| 7 | BROWN |
| 8 | ORANGE |
| 9 | WHITE |
| 10 | GRAY |
| 11 | PINK |
| 12 | TEAL |
| 13 | SLATE |
| 14 | INDIGO |
| 15 | NAVY |
| 16 | WHITE |

- BATTERY
- MOTOR WINDING
- NORMALLY OPEN CONTACT
- SINGLE POLE DOUBLE THROW CONTACT
- NORMALLY OPEN SLOW MAKE SWITCH
- NORMALLY OPEN SNAP SWITCH
- NORMALLY CLOSED SNAP SWITCH HELD OPEN
- SINGLE POLE DOUBLE THROW SNAP SWITCH
- CONTACTOR OR RELAY COIL
- MOTOR SERIES FIELD
- RESISTOR
- INTERLOCK

INDUSTRIAL TRUCK DIVISION
 CLARK EQUIPMENT CO.
 WIRING DIAGRAM (FOR
 NARROW AISLE
 IN-14477

IN-14477

